

# BED FRAME

## FULL

### ASSEMBLY INSTRUCTIONS

Before assembling your bed frame, please read through these instructions carefully and familiarize yourself with the different parts.

**ATTENTION!** If you receive a damaged or defective item,

please contact us



#### PARTS LIST

- ① **FOOT RAIL**                    **2 PCS**
- ② **LEFT LEG**                    **2 PCS**
- ③ **RIGHT LEG**                   **2 PCS**
- ④ **SIDE RAILS**                   **2 PCS**
- ⑤ **SUPPORT RAIL**               **2 PCS**
- ⑥ **SLAT KIT**                    **2 SET**
- ⑦ **SUPPORT LEG**                **2 PCS**

#### HARDWARE

- ① JCB M6 X 70mm (2 3/4") - 4 pcs      ② Cap Nut - 6 pcs
- ③ Spare - 1 pc                              ④ JCB M8 X 40mm ( 1 5/8") - 2 pcs
- ⑤ Spare - 1 pc                              ⑥ Spare - 1 pc
- ⑦ Barrel nut - 4 pcs                      ⑧ Wood screw(1 1/4") - 14 pcs
- ⑨ Spare - 1 pc                              ⑩ Spare - 1 pc
- ⑪ Wood dowel 10 X 30mm( 1 1/8") - 8 pcs
- ⑫ Spare - 1 pc                              ⑬ 2pcs ⑭ 2pcs
- ⑮ V Wood button - 4 pcs                ⑯ Split & Flat Washer
- ⑰ Spare - 1 pc                              ⑱ Spare - 1 pc
- ⑲ JCB M6 X 30mm ( 1 1/8") - 6 pcs    ⑳ Spare - 1 pc
- ㉑ Spare - 1 pc

NOTE: WE INCLUDE SPARE HARDWARE IN CASE DAMAGE OCCURS DURING ASSEMBLY.

#### Step 1

Attach the legs (2) and (3) to foot rail (1), using wood dowel (C) JCB M6 X 70mm (A) and barrel nut (B). Tighten with the Allen wrench (J). Cover holes with V wood button (D) as shown. Repeat the other.

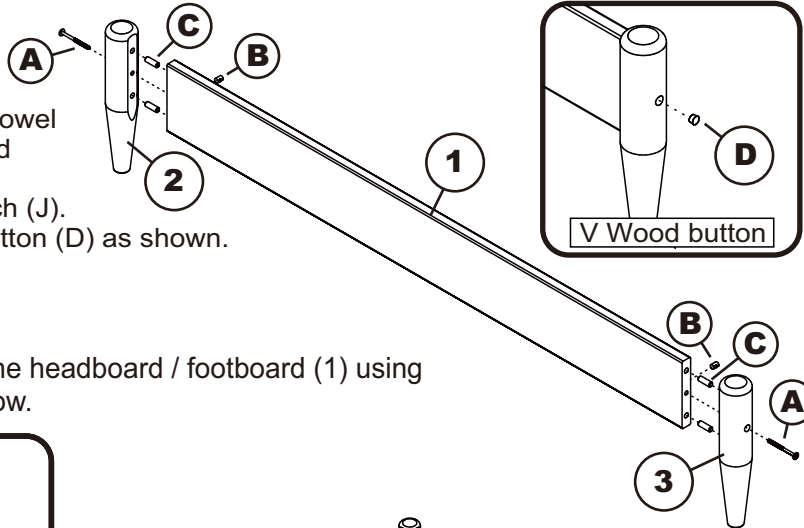

#### Step 2

Attach the side rails (4) to the headboard / footboard (1) using the bed hook as shown below.

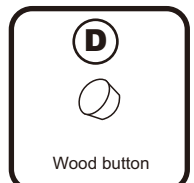
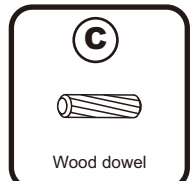
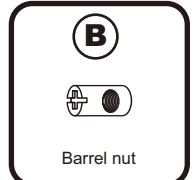
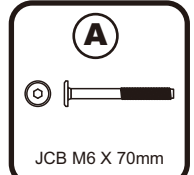
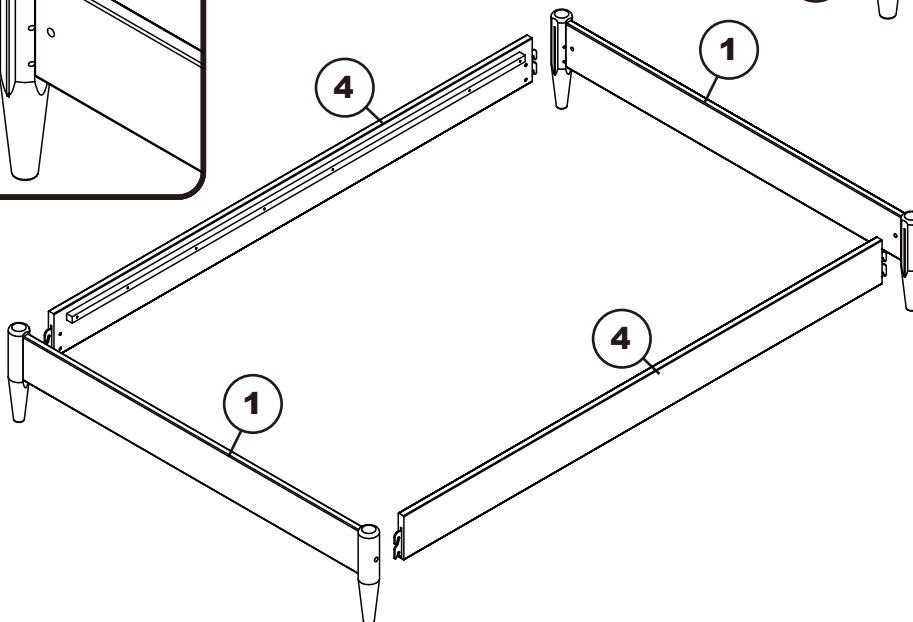
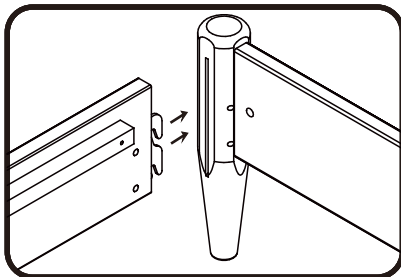

# FULL

## Step 3

Attach support leg (7) to support rail (6) as shown below. Using JCB M8 (G) split and flat washer (I) tighten with Allen wrench M5 (K). Repeat the other.

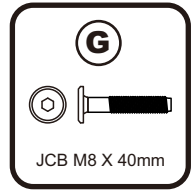
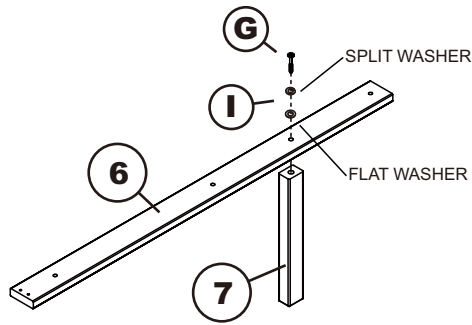

## Step 4

Attach support rail (6) to the slat kit (5) as shown below using JCB M6 X 30mm (E) and cap nut (F). Tighten with Allen wrench M4 (J). Using wood screw (H) tighten with Phillips head screwdriver. (Customer supplied)

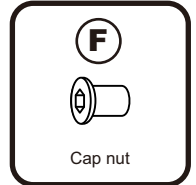
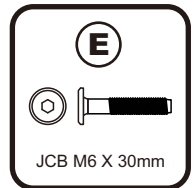
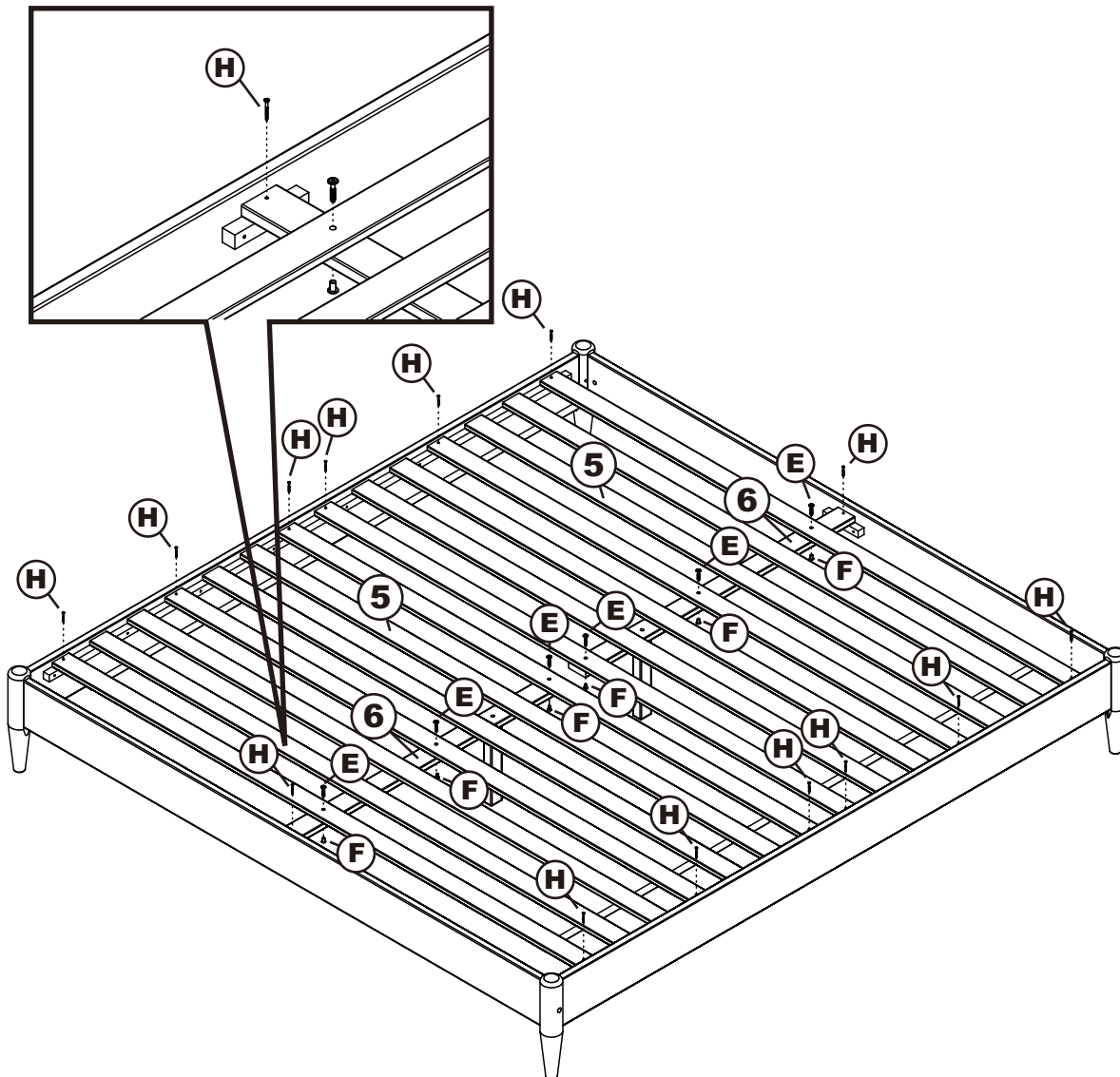

**Congratulations!**

Your bed is now ready for use.

We recommend that you periodically recheck that all screws are tight to ensure lasting safety.

# HEADBOARD

## ASSEMBLY INSTRUCTIONS

Before assembling your headboard, please read through these instructions carefully and familiarize yourself with the different parts.

**ATTENTION!** If you receive a damaged or defective item, please contact us



### PARTS LIST

- 1 HEADBOARD PANEL 1 PC
- 2 LEFT LEG 1 PC
- 3 RIGHT LEG 1 PC

Instructions apply for bed sizes  
TWIN > FULL > QUEEN > KING

### HARDWARE

- A** Wooden dowel - 4 pcs  
Spare - 1 pc
- B** JCB M6 X 35mm (1 3/8") - 4 pcs  
Spare - 1 pc
- F** Allen wrench - 1 pc  
Spare - 1 pc

#### HARDWARE FOR METAL BED FRAME

- C** JCB M6 X 25mm (1") - 4 pcs  
Spare - 1 pc
- D** Flat washer - 4 pcs  
Spare - 1 pc
- E** Split washer - 4 pcs  
Spare - 1 pc

NOTE: WE INCLUDE SPARE HARDWARE IN CASE DAMAGE OCCURS DURING ASSEMBLY.

### Step 1

Attach the legs (2) and (3) to headboard panel (1), using wooden dowels (A) and JCB (B). Tighten with the Allen wrench (F).

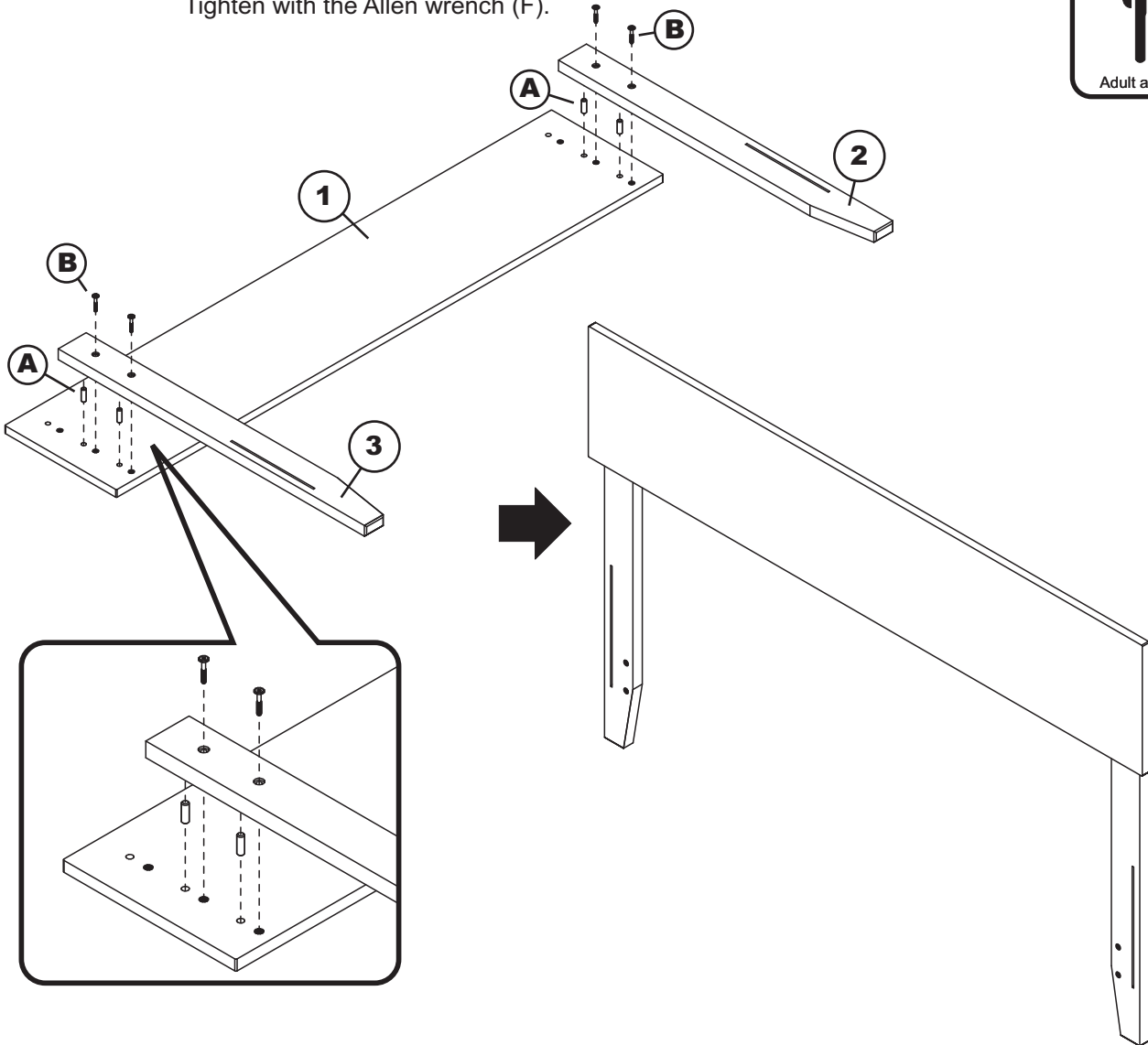

If you purchased a wood headboard to attach to metal bed frame, please refer to page 2.

## ATTACHING HEADBOARD TO METAL BED FRAME

### ASSEMBLY INSTRUCTIONS

Before assembling your bed, please read through these instructions carefully and familiarize yourself with the different parts.

Instructions apply for bed sizes  
**TWIN > FULL > QUEEN > KING**



Adult assembly

Metal bed frames are sold separately from wood headboards. The hardware shown on this page is supplied with your wood headboard for attaching the bed frame to the headboard. The metal bed frame is supplied with its own assembly instructions and hardware.

#### Step 1

Attach the headboard assembly to the metal frame using JCB (C), flat washer (D), and split washer (E) then tighten with Allen wrench (F), as shown below.

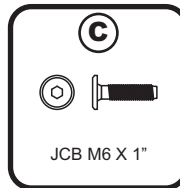
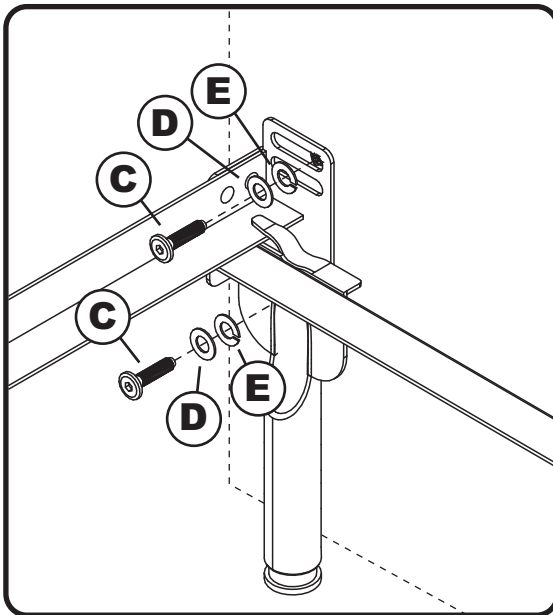

JCB M6 X 1"

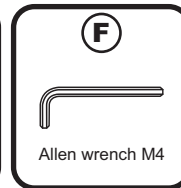

Allen wrench M4

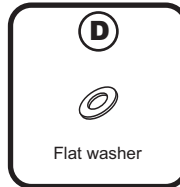

Flat washer

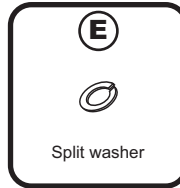

Split washer

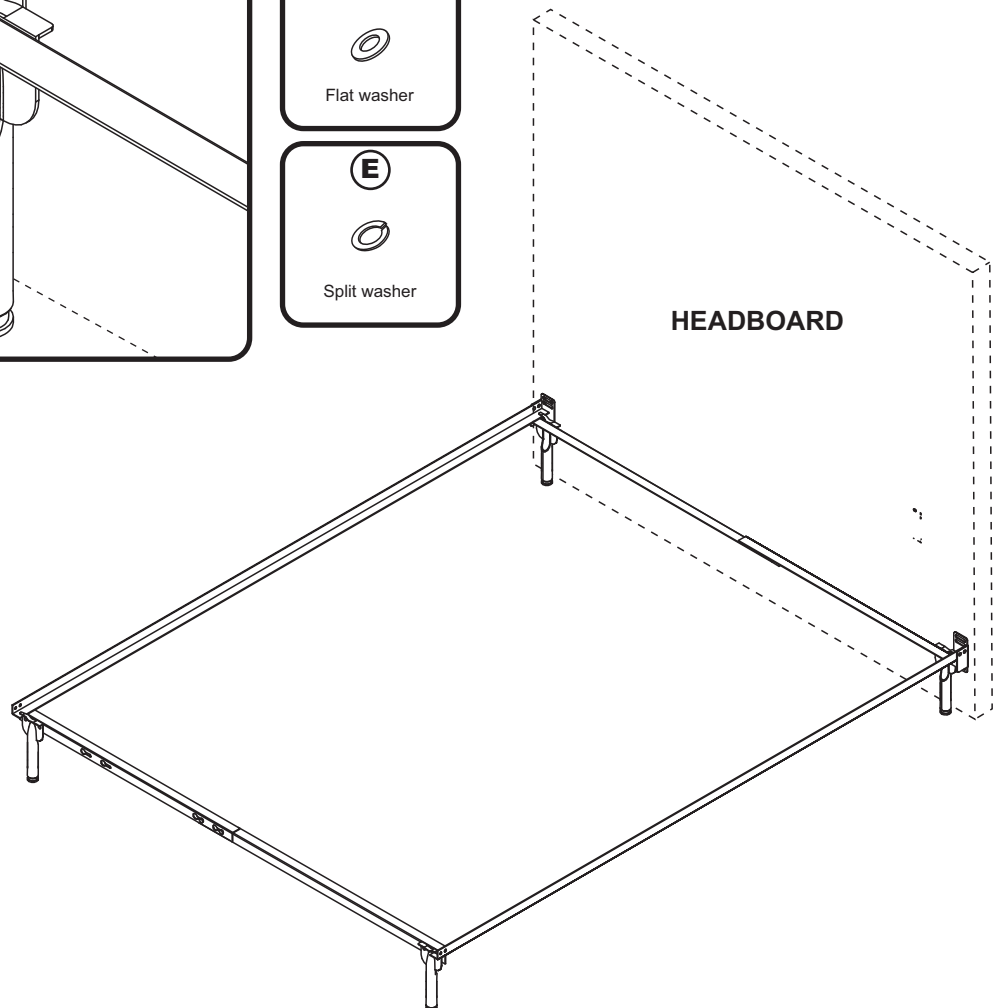

### Congratulations!

Your bed is now ready for use.

To ensure lasting safety, we recommend that you periodically check that all screws are tight and all parts are secure.