

ASSEMBLY INSTRUCTIONS

029-910 Rectangular Coffee Table

TOOLS REQUIRED:

Phillips Head Screwdriver (Not Provided)





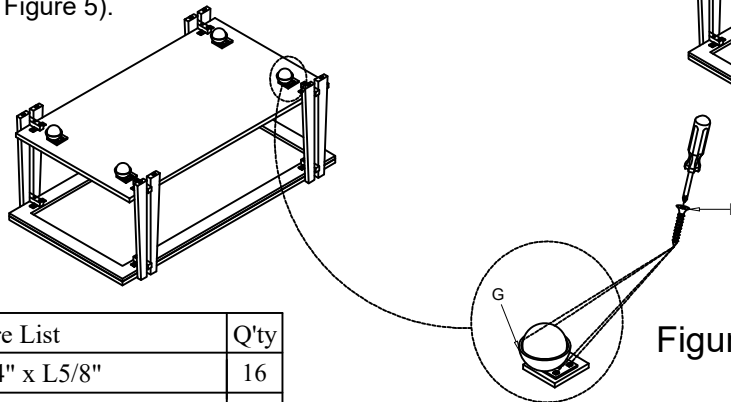
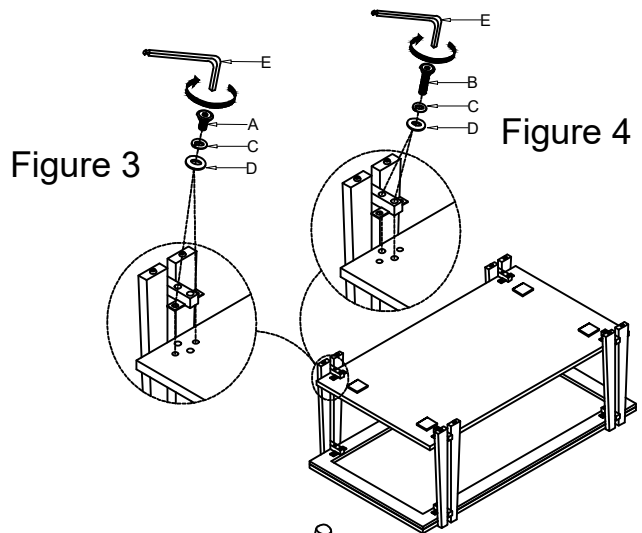
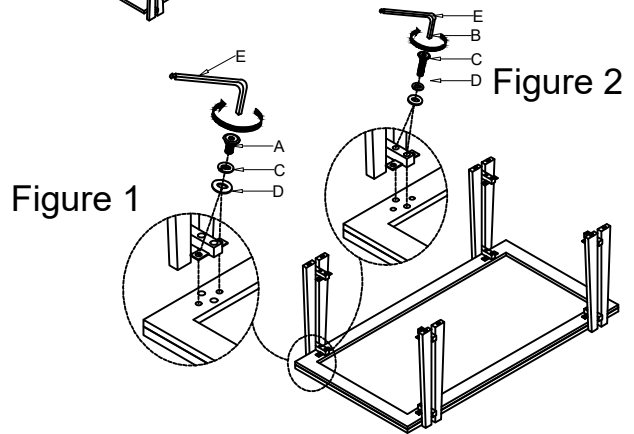
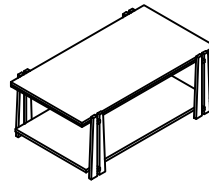

BEFORE YOU START:

1. Check the parts against the parts list to make sure all items are present.
2. Assemble your furniture on a soft, flat surface to avoid scratching the finish.
3. **CAUTION:** Do not over tighten screws, nuts or bolts during assembly.
4. Your furniture may require occasional tightening.

INSTRUCTIONS:

1. Turn the table top upside down on to a clean soft surface.
2. Attach legs to the Table, using Flat washer (D), Lock washer (C), Bolt (A) and Bolt (B). With Allen key (E). (See Figure 1 & 2).
3. Install shelf into legs, align pre-drilled holes in base with hole in bottom of Legs, using Flat Washer (D), Lock Washer (C), Bolt (A) and Bolt (B). (See Figure 3 & 4). Tighten all bolts with Allen key (E).
4. Attach caster using Screw (F). Tighten all screws by Phillip head screw driver (not provided). (See Figure 5).



No.	Hardware List	Q'ty
A	 Bolt Ø1/4" x L5/8"	16
B	 Bolt Ø1/4" x L1-1/4"	16
C	 Lock Washer Ø1/4"	32
D	 Flat Washer Ø1/4"	32
E	 Allen key 4mm	1
F	 Screw (Ø8x5/8")	16
G	 Caster (Ø50*H64mm)	4