

## TABLE

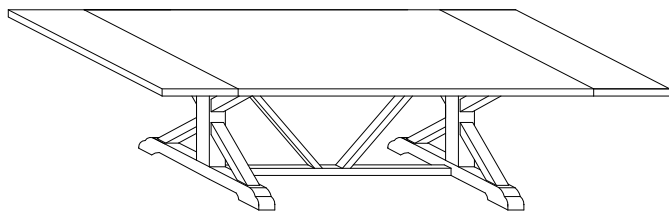



Thank you for purchasing the **TABLE**!

Before you start, here is some helpful advice:

1. We suggest you spend a short time reading through this leaflet and then follow the simple step by step instructions.
2. Owing to the size and weight of the table, we recommend that it is assembled by two adults, on a carpeted or padded area, in the room that it is intended for. Approx assembly time: 30 minutes.
3. Please do not use any tools other than those provided or recommended in these instructions.
4. Please do not throw away any of the packaging or the instruction until you have checked all the components and hardware and the furniture is fully assembled. Please ensure that the packaging is disposed of in a safe environmentally friendly way.
5. Assemble all components loosely until advised to tighten. Depending on use, it may be necessary to tighten the components from time to time, so please save the tools that has been provided.
6. Please keep all fitting out of reach of children.



### Hardware:

A		Bolt M8x35mm	x6
B		Bolt M8x70mm	x8
C		Flat Washer M8	x14
D		Allen Wrench M5	x1

### Component:

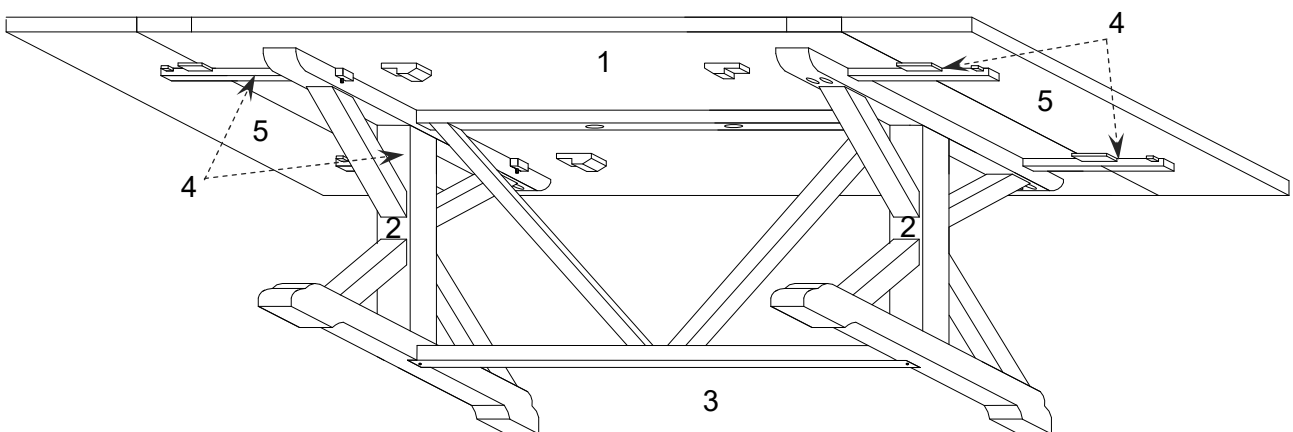

1	Table Top	x1	2	Table Leg	x2	3	Table Across	x1
4	Support Rail	x4				5	Leaf	x2

**TABLE**

**STEP 1:**



Please put **Table Legs (2)**, **Table Across (3)** upside down on a carpeted or padded area.

Position **Table Across (3)** to **Table Legs (2)** as shown.

Insert 2 pieces of **Bolt (A)** with 2 pieces of **Flat Washer (C)** into the pre-drilled holes on **Table legs (2)** through the pre-drilled holes on **Table Across (3)**.

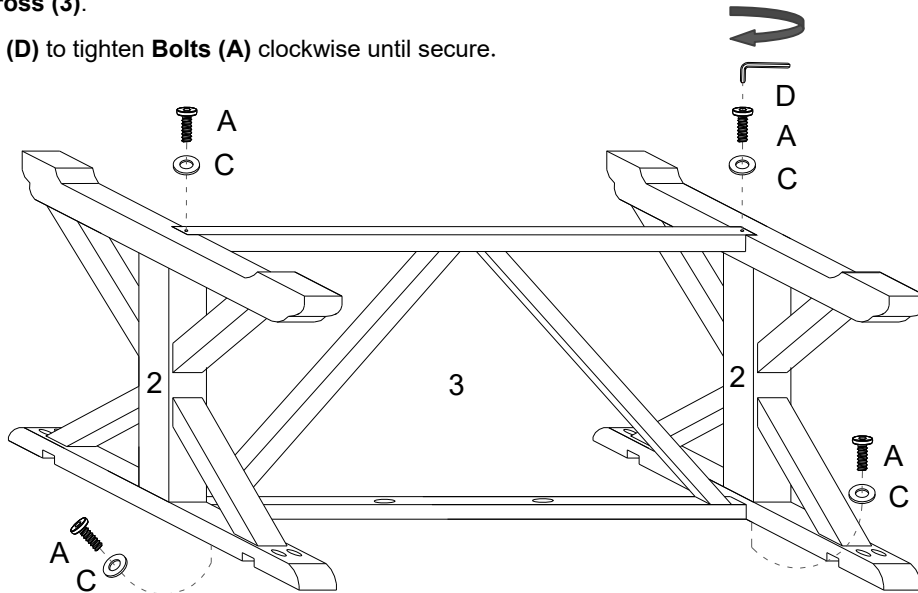
Use **Allen Wrench (D)** to tighten **Bolts (A)** clockwise until secure.



		
Ax4	Cx4	Dx1

Hardware & Tool required

**STEP 2:**

Please put **Table Top (1)** upside down on a carpeted or padded area.

Remove 1 piece of pre-installed bolts from each piece of **Support Rail (4)**.





Position the assembled **Table Legs(2)**, **Table Across (3)** to **Table Top (1)** as shown.

Insert 8 pieces of **Bolt (B)** with 8 pieces of **Flat Washer (C)** into the pre-drilled holes on **Table Top (1)** through the pre-drilled holes on **Table Leg (2)**.

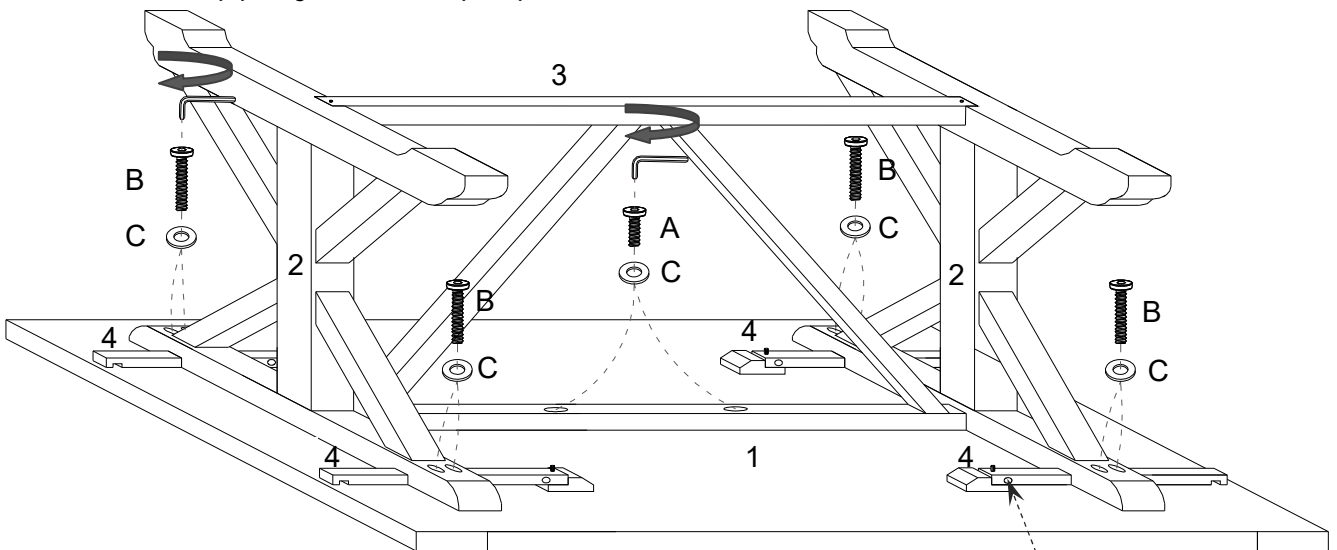
Insert 2 pieces of **Bolt (A)** with 2 pieces of **Flat Washer (C)** into the pre-drilled holes on **Table Top (1)** through the pre-drilled holes on **Table Across (3)**.

Use **Allen Wrench (D)** to tighten all **Bolts (A&B)** clockwise until secure.



			
Ax2	Bx8	Cx10	Dx1

Remove the pre-installed Bolts from each piece of **Support Rail (4)**.

Hardware & Tool required

## TABLE

---

### STEP 3:

Carefully turn over the assembled table.

If you want to use **Leafs (5)**, please fully extend **Support Rails (4)** and put **Leafs (5)** to **Support Rails (4)** as shown.

Insert the removed 4 pieces of Bolt from step 2 into the pre-drilled holes on bottom of **Table Top (1)** through the pre-drilled holes on bottom of **Support Rail (4)**.

Use **Allen Wrench (D)** to tighten the removed Bolts from step 2 clockwise until secure.

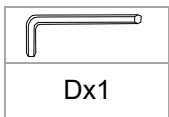
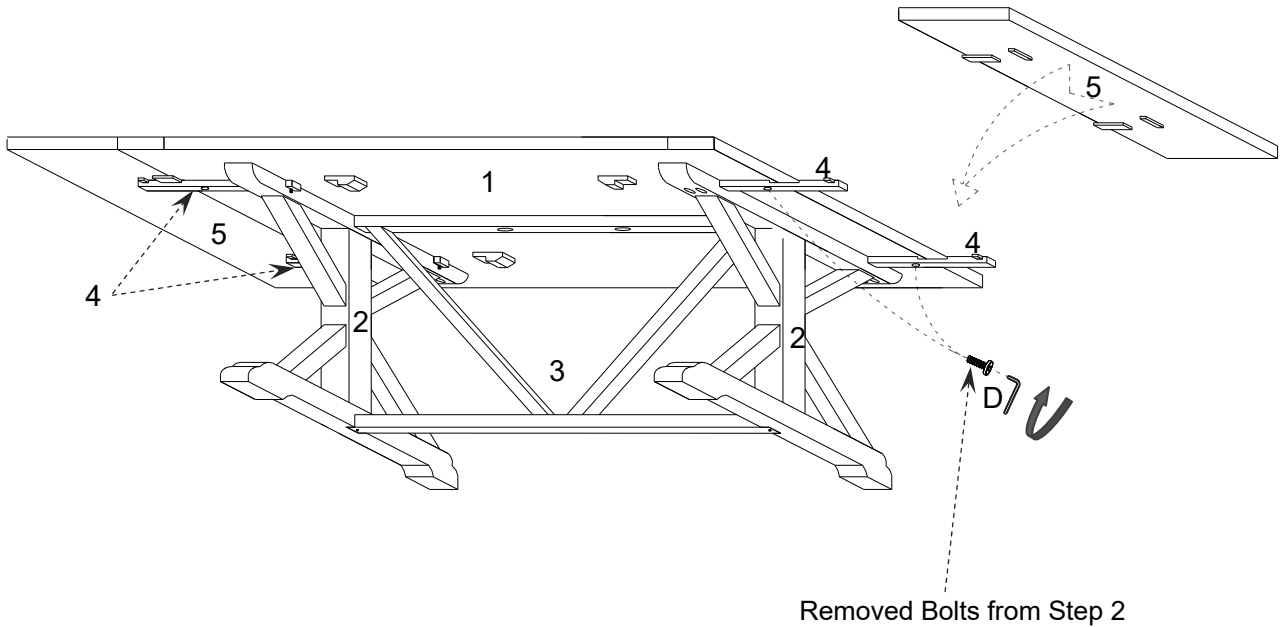

Hardware & Tool required

---

### STEP 4:

Position the assembled table to the location your desire.

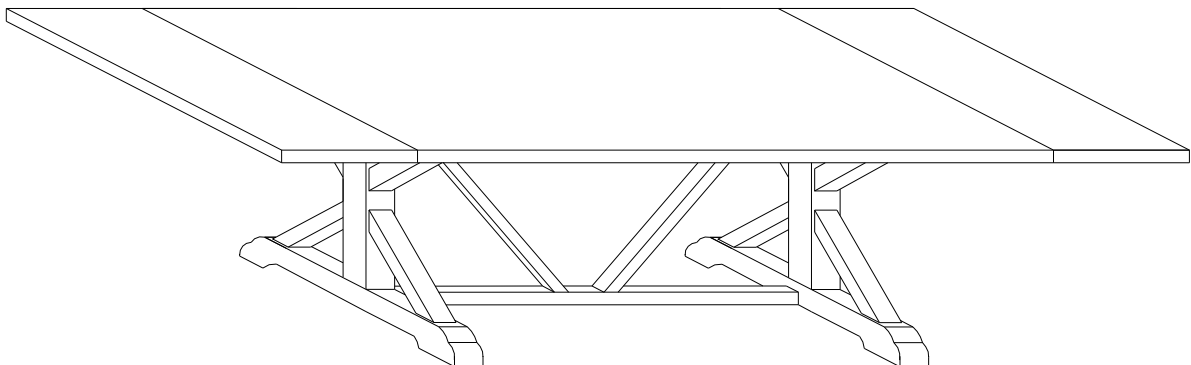

Assembly is complete. Your table is ready to be used now!