

Please check contents **before** assembly. If any items are missing or damaged, **do not take the unit back to the store**. Call 1-800-427-5136 for customer service and we will save you time by correcting any problems directly for you.

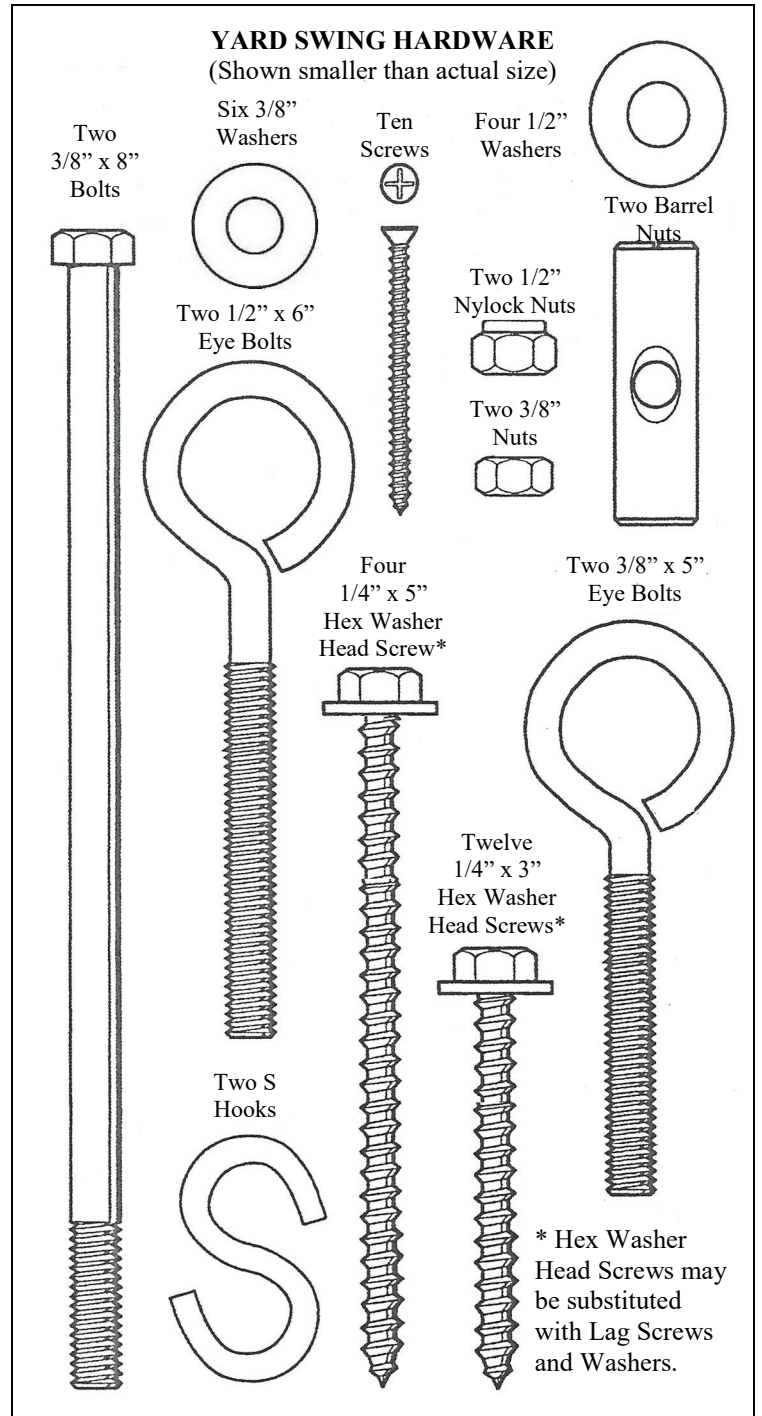
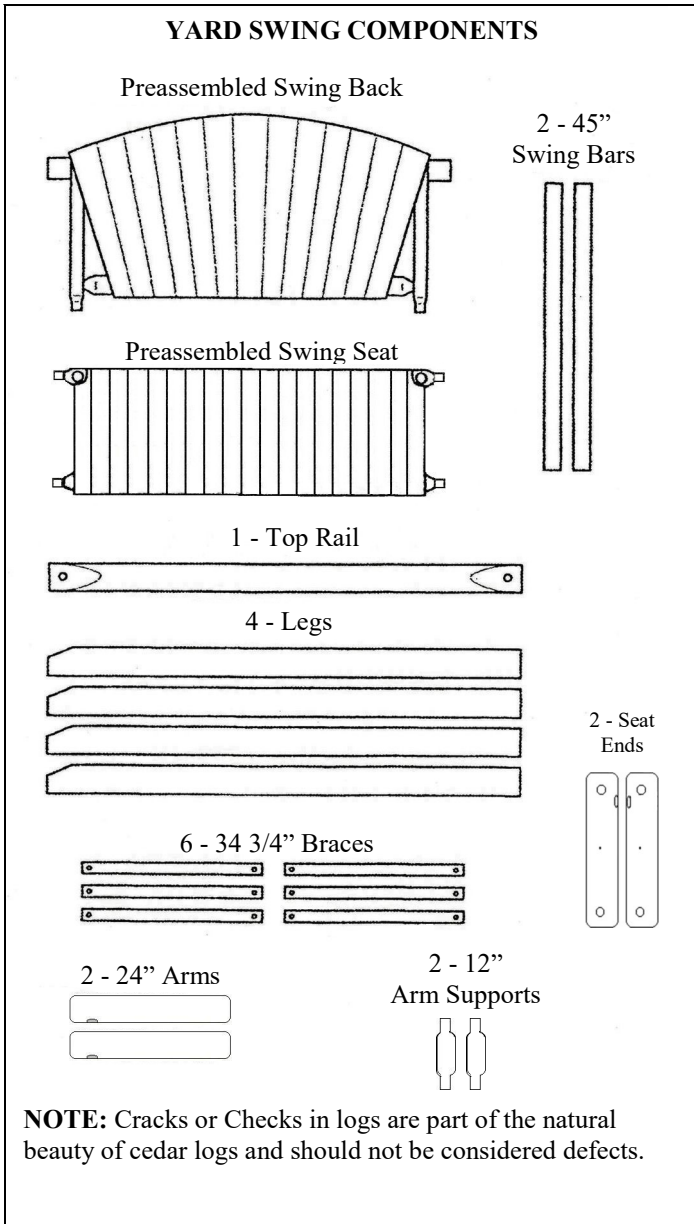

**NOTE:**

- Read all instructions before starting.
- To start hex washer head screws, hammer into wood about 1/2" then use wrench or socket to tighten.
- Do not completely tighten any screws until the unit is fully assembled and setting on a level surface.
- Use a rubber mallet (or a block of wood between the hammer and the unit) to drive doweled ends into holes as far as possible.

*NOTE: Using a battery or electric power drill with a socket attachment will make assembly easier and faster.*

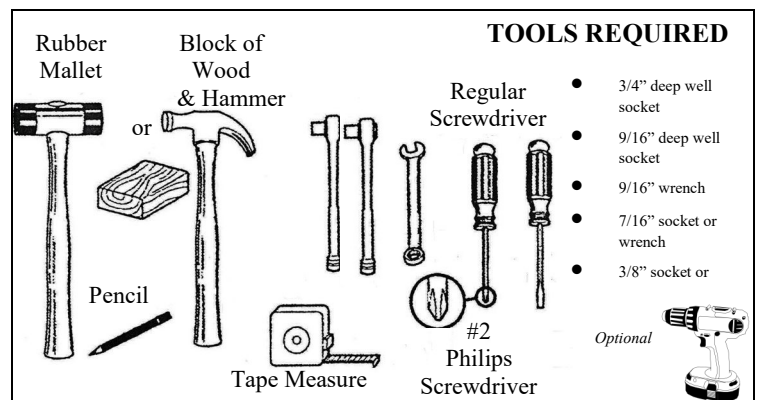

## A-FRAME ASSEMBLY

STEP 1

See figure 1A. Place a 1/2" washer on the 6" eye bolt. Drive the eye bolt through the hole in top rail, on the opposite side from the counterbore. Place 1/2" washer on the 6" eye bolt in the counterbore, then place nylock nut on the eye bolt in the counterbore. Tighten with 3/4" socket. Repeat this process on the other side. See figure 1B Lay top rail on the ground with eye bolts down. Lay top of legs parallel to top rail as shown in figure 1B and attach all legs with 8" bolts, 3/8" washers, and nuts, using a washer on both ends of the bolt. Repeat process on opposite side. DO NOT TIGHTEN YET.

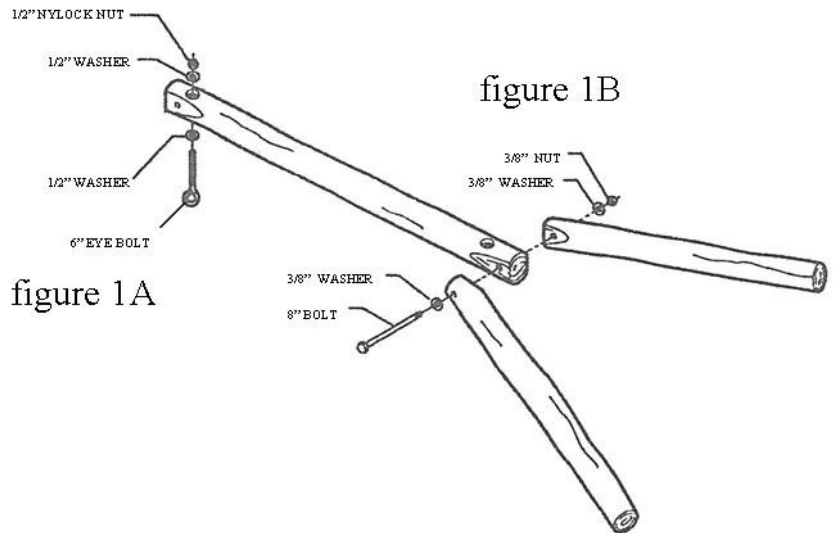

STEP 2

Pre-measure and mark rail and legs for braces. Mark position of leg braces 32" from the top of the legs as illustrated in figure 2. Mark position of rail to leg brace 22 1/2" from the end of top rail and 24" from the top of legs as shown in figure 2.

This will set your swing seat at an average height from the ground. If you wish to raise the seat higher, attach leg braces more than 32" from the top of the legs. To lower the seat height, attach them at a point less than 32" from the top of the legs.

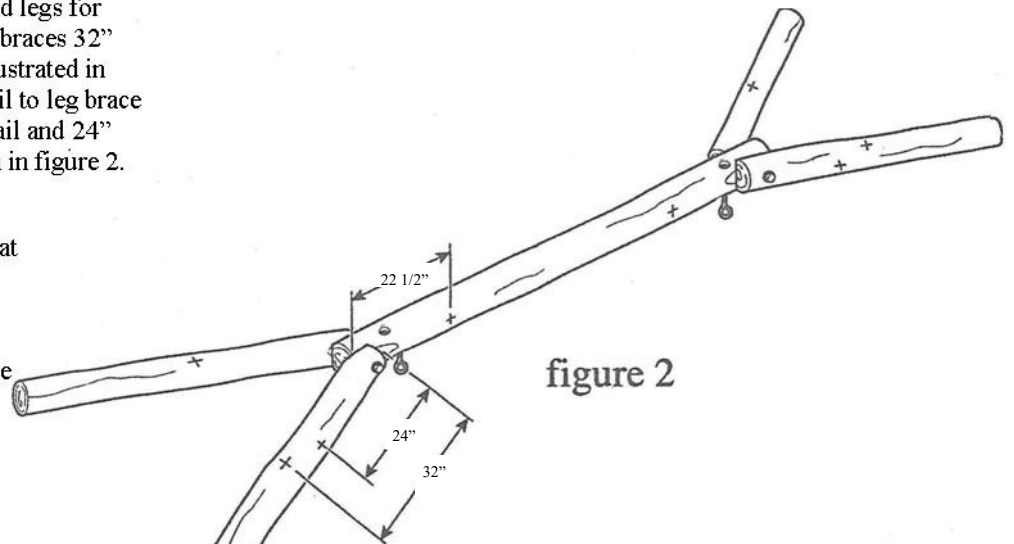

STEP 3

(TWO PEOPLE RECOMMENDED.) Lift top rail with legs attached allowing legs to swing into position underneath. Attach braces (as illustrated in figure 3) to pre-marked positions tapping 3" hex washer head screws with a hammer to start them into legs and tightening them with a 7/16" wrench. After all 6 braces are attached and frame is setting on firm level surface, tighten them securely. Now tighten the nuts and bolts that attach the legs to the top rail with 9/16" wrench, making sure bolts are **TIGHT**.

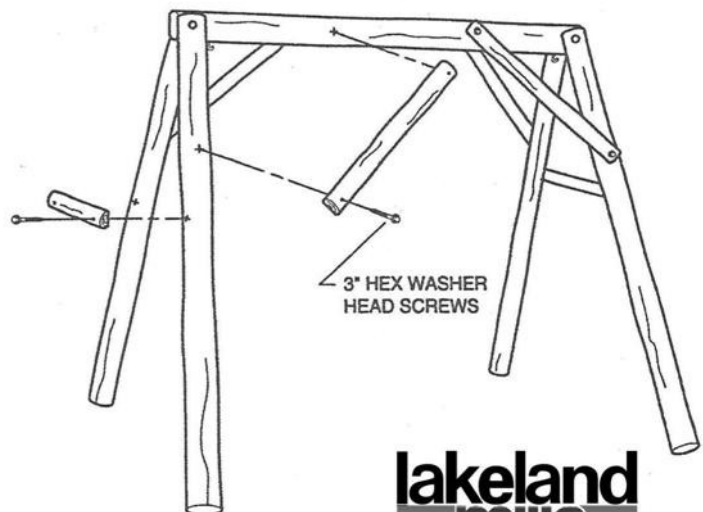

STEP 4

Tighten all lag screws firmly. Your unit is now ready for finishing or immediate use. Relax and enjoy!

figure 3

**lakeland**  
mills

## SEAT ASSEMBLY

- STEP 4a Install seat end onto seat. Align holes in seat end with dowels on seat as shown in picture right. Repeat on other side. Secure with screws perpendicular to dowel. (See circle figure below). **IMPORTANT:** The single hole **should** be placed toward the **front** of the seat. (See below).

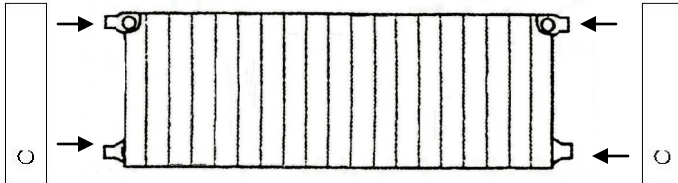

**Please Note:** After you have installed the seat ends onto the seat secure with (4) 2 1/2" screws. See figure below for how to put screws in..

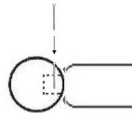

- STEP 4 Lay assembled seat on ground. Insert doweled ends of uprights on assembled back into 1-1/4" holes on the back seat rail, adjusting uprights in or out as needed to align properly. Do not tap on seat back with hammer.

To keep the seat rail from splitting, lay the back on the ground and drive the seat on by hitting on the bottom of the seat assembly.

- STEP 5 Insert 12" arm support into hole in the arm, then into hole in the top of the seat end. Drive doweled ends in as far as possible. Fasten arm to the back upright by tightening the preinstalled 1/4" x 5" hex washer head screw into the pilot hole in the arm with a wrench. Repeat on other arm.

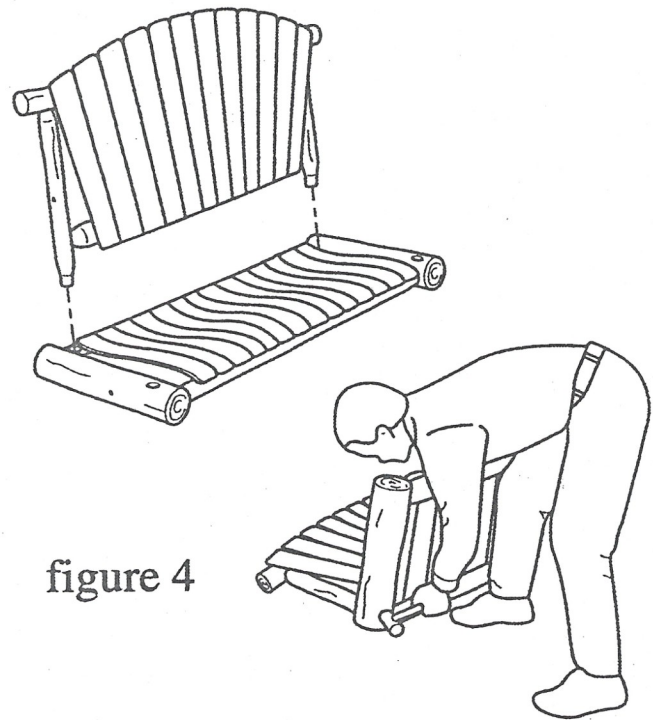

figure 4

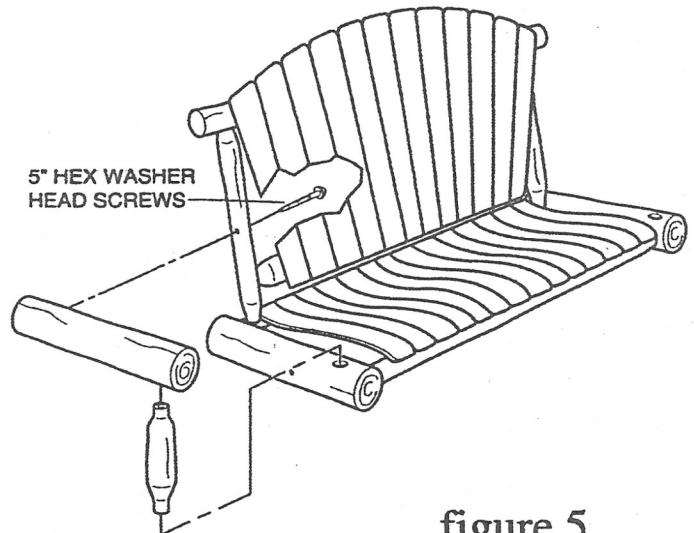

figure 5

- STEP 6 Secure all doweled joints in place with screws perpendicular to the doweled end as shown at right.

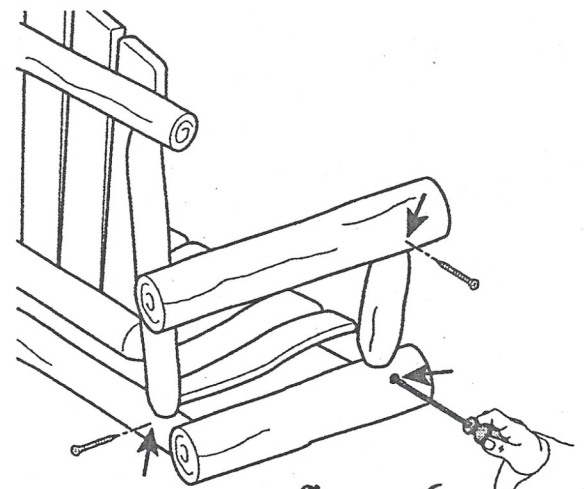
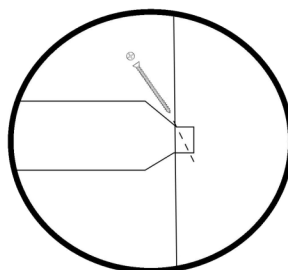
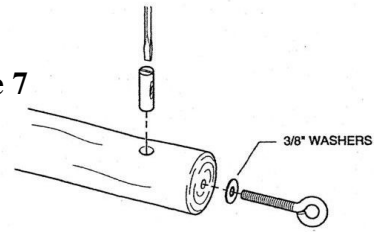

figure 6

STEP 7 Place barrel nut into horizontally drilled hole in end of swing bar. Position barrel nut with screwdriver and screw in 5" eye-bolt with 3/8" washer as shown. **TIGHTEN DOWN SECURELY!** Repeat on other swing bar. Figure 7

Figure 7



STEP 8 Fasten swing bars to side of unit as shown. With hammer, tap a 5" hex washer head screw through the bottom hole in swing bar and into pilot hole (11" from the back of the seat end) on seat end. Tap 5" hex washer head screw through the upper hole in the swing bar and into arm about 1/2" deep at the point 15" from the back of the arm. (This gives a suggested pitch of the seat. You may change the pitch by altering the location of the hex washer head screws in the arm.) Tighten down hex washer head screws. Figure 8

Figure 8

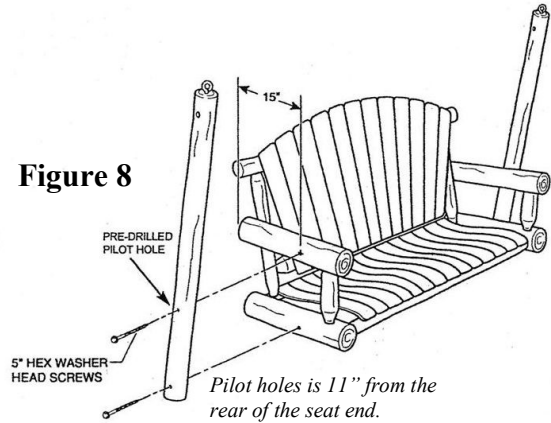

NOTE *If you have hardware left over after completing your unit, it most likely has been assembled incorrectly, and may not be safe to use. Please call Customer Service at 800-427-5136 for assistance.*

### SEAT TO FRAME ASSEMBLY

STEP 9 Install the assembled swing to the frame. It is recommended a minimum of two people for this this step.

STEP 10 Tighten all hex washer head screws firmly. Your unit is now ready for finishing or immediate use. Relax and enjoy.

Install on level ground. Install not less than 6' from any obstructions such as a fence, garage, house, overhanging branches, lines, or wires.

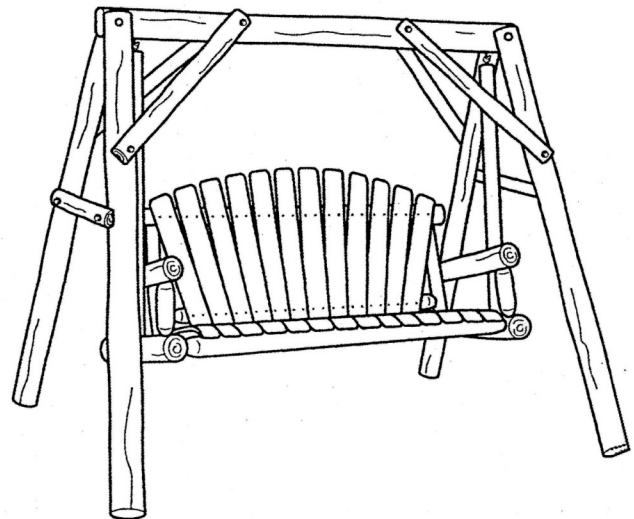

**NOTE:** Check all nuts and bolts for tightness before and during each usage season.

#### Lakeland Mills recommends:

WeatherSeal Premium Oil-Based Exterior Wood Stain & Sealant  
[www.ContinentalProd.com](http://www.ContinentalProd.com)

Look for assembly videos on:



<https://www.youtube.com/watch?v=-OmqxSrmkYM>

<https://www.youtube.com/watch?v=jg2BRgWMVpg&t=1s>

Like  
**lakeland  
 mills**  
 on



Factory: 1 Lakeland Place, Edmore, Michigan 48829, Phone: 800-427-5136 Fax: 989-427-5824  
[www.lakelandmills.com](http://www.lakelandmills.com)