

# COTLIN

## Ice & Water Dispenser INSTRUCTION MANUAL

PROFESSIONAL  
AND  
TRUSTWORTHY

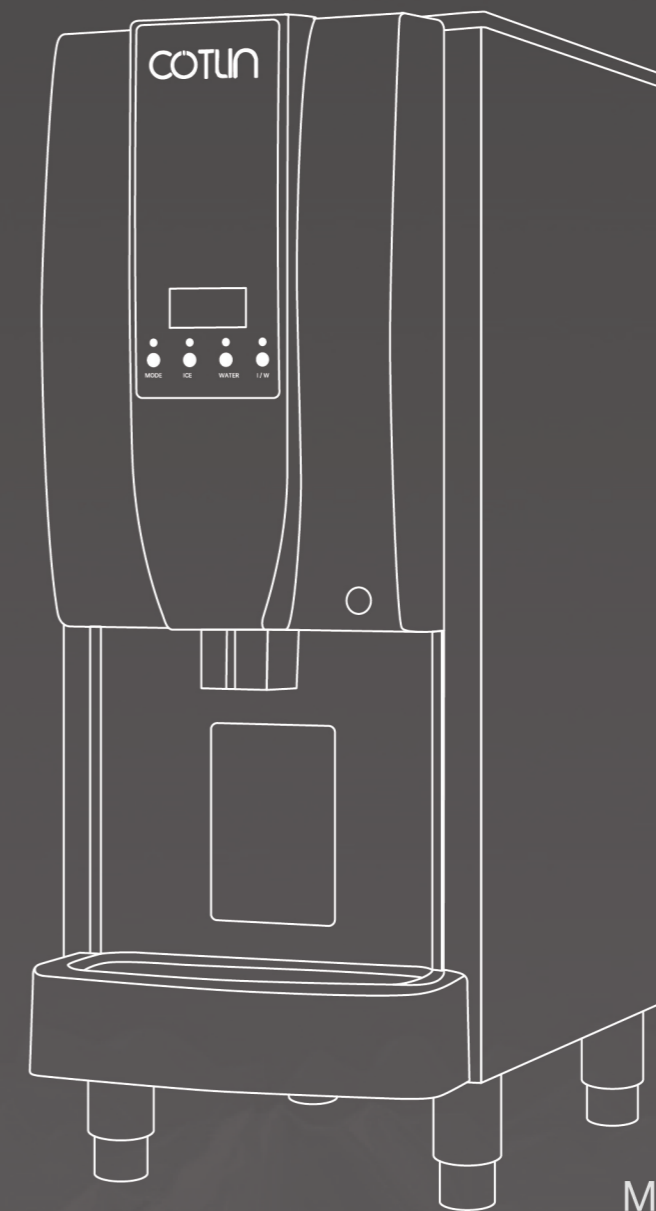

Model: HBB-100

# CONTENTS

Product Schematic Diagram Description	1
Important Safety and Operating Instructions	2
Installation and Operating Instructions	3
Working Program Overview	4
Key Functions Description	5
Daily Maintenance And Precautions	7
Refrigeration System Schematic Diagram	7
Control Board Circuit Diagram	8
After-Sales Service Information	9
Troubleshooting: Common Faults and Solutions	9

# Product Schematic Diagram Description

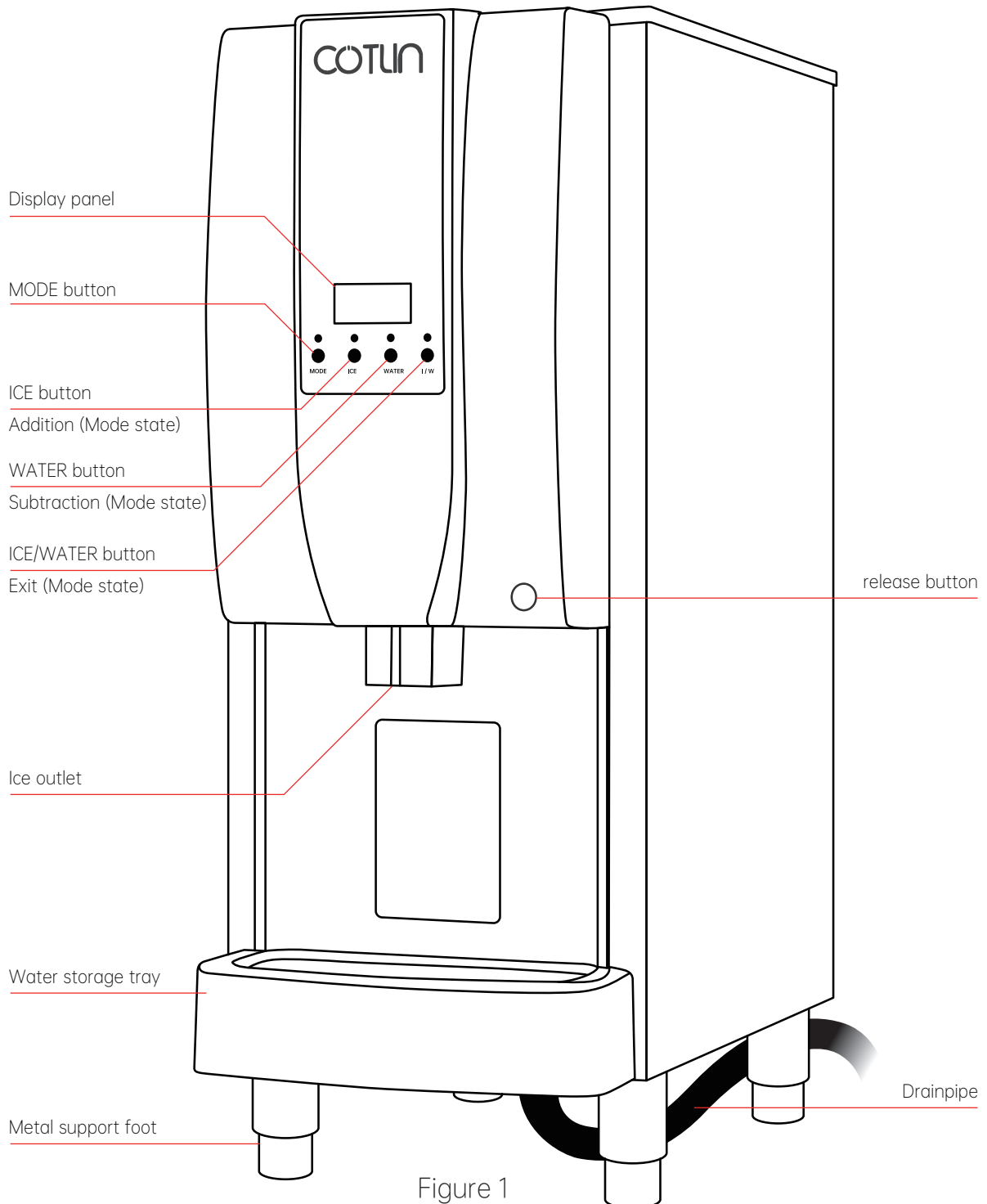

# Important Safety And Operating Instructions



## To avoid bacterial contamination of ice

- 1: Do not store any other items in the refrigerator.
- 2: Keep the ice shovel clean and free from contamination.
- 3: Keep the refrigerator door closed at all times.
- 4: When cleaning the floor around the machine, prevent dust from being drawn into the fan.



## To avoid damage to the machine

- 1: Unplug the power cord when the ice machine is not in use to completely cut off the power supply.
- 2: Do not disconnect the power supply while the machine is running.
- 3: Open and close the refrigerator door gently; do not pull or slam the door.
- 4: Do not place heat-generating items on or around the top of the machine, as this may affect normal operation.
- 5: When moving the machine, lift it carefully to avoid damaging the supporting feet. Do not push or drag it on flat surfaces.

Always use accessories provided by our company to ensure proper operation.

# Installation And Operating Instructions

## 1. Installation Position

This Ice & Water Dispenser is for indoor use only. The normal ambient temperature range is 1°C to 46°C, and the normal water supply temperature range is 3°C to 35°C. Long-term operation outside these ranges may reduce ice production and shorten the service life of the machine.

Do not install the dispenser near ovens, stoves, or other high-temperature equipment. The dispenser can be placed on a workbench or flat floor. Ensure the unit is level after installing the adjustable feet.

Leave at least 15 cm clearance at the rear, sides, and top of the unit for proper ventilation and easy maintenance.

Do not install the dispenser in an environment without a drainage outlet.

Do not place any objects on top of the dispenser or near the cooling vents.

Do not operate the dispenser if the ambient temperature is below 0°C.

## 2. Installation Notes

Improper installation may cause injury or equipment damage. The manufacturer will not be responsible for such losses.

The dispenser must be installed in a location where the power plug is easily accessible.

## 3. Water Supply Connection

Use potable (drinking) water only.

The water supply pressure must be between 0.5 and 8 bar. If the pressure exceeds 8 bar, a pressure-reducing valve must be installed. Avoid bending the water inlet pipe repeatedly.

To prevent backflow into the refrigerator, connect the drain hose as shown (Figure 2).

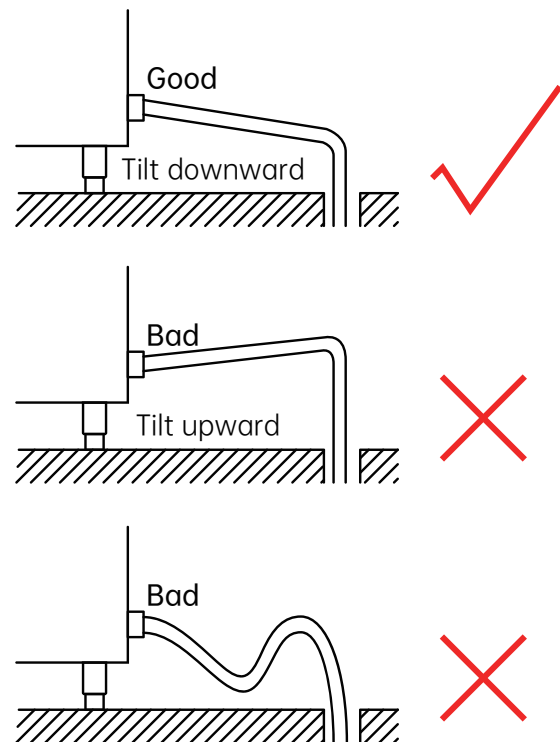
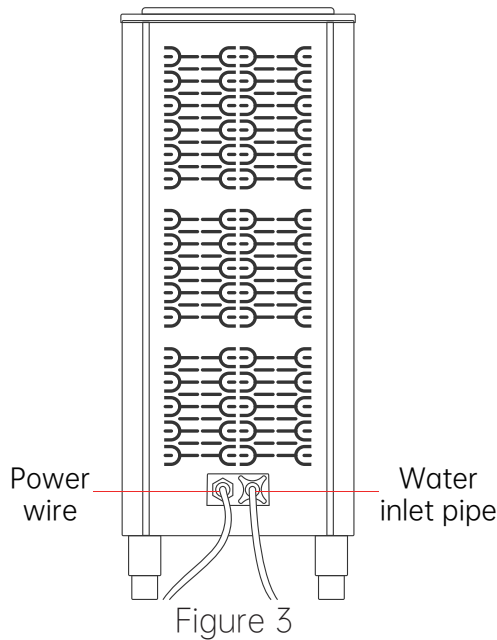
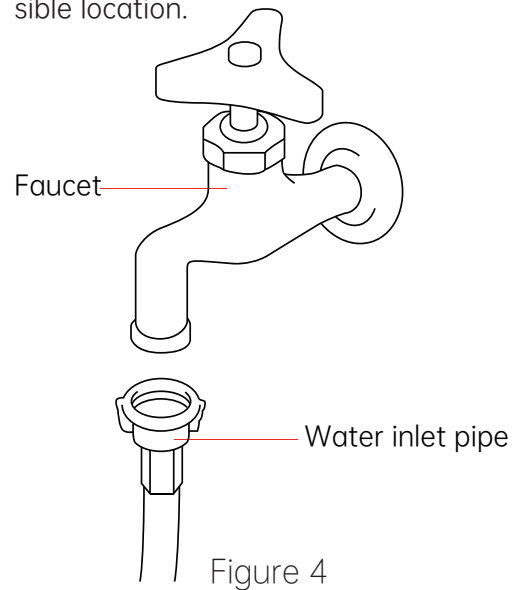

Figure 2

Connect the white inlet hose (provided as an accessory) to the inlet port at the rear of the dispenser (Figure 3).



Connect the other end of the inlet hose to the faucet (Figure 4). Ensure the plastic gasket is properly seated before tightening. For convenience and safety, it is recommended to install a stop valve at an accessible location.



## Working Program Overview

### 1. Power On

Before starting, check all machine accessories to ensure they are intact, unblocked, and not damaged.

Turn on the water supply and the power switch.

At startup, all five indicator lights flash for 1 second. Then, the Power indicator (1) and the Water level indicator (3) flash simultaneously. The water level light turns off when the tank is full.

After 3 minutes, the ice-rotating motor starts. Another 3 minutes later, the compressor begins to work, and the fan operates under the control of the condensing temperature.

### 2. Ice Making

About 5 minutes after the refrigeration system begins operating normally, the machine starts producing granular ice.

Under normal conditions, ice production stops automatically when the Ice Full indicator is on.

After ice is removed, the machine will automatically restart ice making.

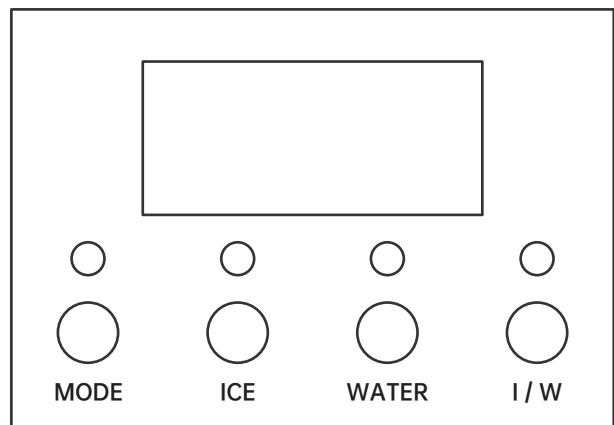

### 3. Stop Operation

The machine may stop under the following conditions:

**Normal stop:** When the ice bucket is full or the machine is shut down manually. The compressor stops first; after 3 minutes, the ice rotor and fan stop. The Ice Full indicator (2) lights up red.

**Low water:** When the water tank is empty, the machine shuts down automatically. All components stop after 3 minutes, and the Water Level indicator (3) lights up.

**Overheating or fan failure:** If the ambient temperature is too high or the fan malfunctions, the compressor shuts down first, followed by complete stop after 3 minutes. The High-Pressure indicator (4) lights up.

**Motor speed fault:** If the ice-rotating motor speed fails, the machine stops completely, and the Fault indicator (5) lights up.

**High temperature fault:** If a high-temperature fault occurs, the Temperature indicator (4) lights up. Restarting requires pressing the Mode key manually.

### 4. Long-Term Shutdown

If the Ice & Water Dispenser will not be used for an extended period:

Drain all ice cubes from the ice bucket.

Set the control switch to "OFF."

Unplug the power cord or cut off the power supply.

Close the water supply faucet and remove the inlet hose.

Empty and clean the plastic ice-water tray.

If the machine is unused for a long time, or will be exposed to 0 °C or below, take protective measures to prevent damage.

# Key Functions Description

## Key Description

### 1: Entering and Adjusting Settings

**Enter setting:** Press and hold the Setting key for 10 seconds to enter the setting mode.

**Adjust setting:** In setting mode, press the Ice or Water key to modify the selected value.

**Switch parameter:** In setting mode, press the Setting key to switch between parameter options.

**Exit setting:** In setting mode, press and hold the Setting key for 10 seconds to exit, or the system will exit automatically after 10 seconds of inactivity and save the data.

## 2:Setting Item Description

NO.	Functional description	Option range	Default value	Remarks
1	Speed effective	0-1	1	1-ON, 0-OFF閉
2	Delayed startup	1-9	3min	Delayed start press time
3	Fan start and stop	10-25°C	19°C	
4	Photoelectric sensitivity	0-10	10	0 does not detect ice full, 10 is switch ice full, and 0-9 photoelectric ice full
5	Rotational speed protection	0-30PRM	8	
6	Water shortage time	0-9min	5min	
7	Power-on switch-of	0-1	1	This item is invalid
8	Ice full delay	3-240s	10	
9	Single ice fetching timeout	3-240s	10	

## 3: Working States

### Ice-making state

The machine starts with a countdown, then enters the ice-making state.

### Ice full state

When the photoelectric sensor detects ice-full, the system waits for the delay set in Item 8 to confirm, then executes the shutdown process and enters the ice-full state.

### Ice full release state

When ice is not full, the ice-full indicator on the display screen flashes. After a certain delay, the system exits the ice-full state and resumes ice-making.

### Ice and water dispensing

When a cup is placed at the dispensing port, the sensor detects it and automatically starts dispensing ice.

The maximum single ice-dispensing time is 10 seconds (adjustable in Item 9).

After timeout, dispensing stops and must be triggered again.

Manual mode: Press and hold the corresponding key for 3 seconds to start dispensing ice. Release the key to stop.

### Fault state

E-2: Motor failure

E-3: High voltage fault

E-4: High temperature fault

E-5: Water shortage

E-6: Evaporation temperature above 5 °C within 30 minutes of ice making, indicating poor refrigeration. (Unplug the evaporation probe to disable this detection.)

### Emergency Status

In the fault state, short-circuiting the grounding pin and signal pin (two pins on the right) allows the machine to continue making ice normally.

Note: If a fault occurs during the first power-on, the fault code will be displayed immediately.

# Daily Maintenance And Precautions

## Daily Maintenance

- 1: Before carrying out any cleaning or maintenance, ensure that both the power supply and water supply are turned off.
- 2: Keep the inside and outside of the ice machine clean. Wipe with a neutral detergent and a soft dry cloth. Do not wash directly with water or use corrosive cleaners such as acids or alkalis.
- 3: Do not disassemble the water inlet hose or spray the machine with water, as this may cause short circuits, electric leakage, or other hazards.
- 4: Clean the inlet filter and water tank every two months to prevent blockages, odors, or impurities.
- 5: Clean dust from the condenser fins every two months to ensure proper ventilation and heat dissipation. Use a vacuum cleaner and a small brush to remove oil and dust. Do not use sharp metal tools, as they may damage the fins.
- 6: After use, clean the ice machine thoroughly. For long-term storage, clean the refrigerator compartment, dry the internal water with an air duct, and place the machine in a dry, well-ventilated area.
- 7: Perform routine cleaning and maintenance as instructed in the Installation and Operation Manual to extend the service life of the ice machine.
- 8: It is recommended to clean the dust filter once a month.

## Refrigeration System Schematic Diagram

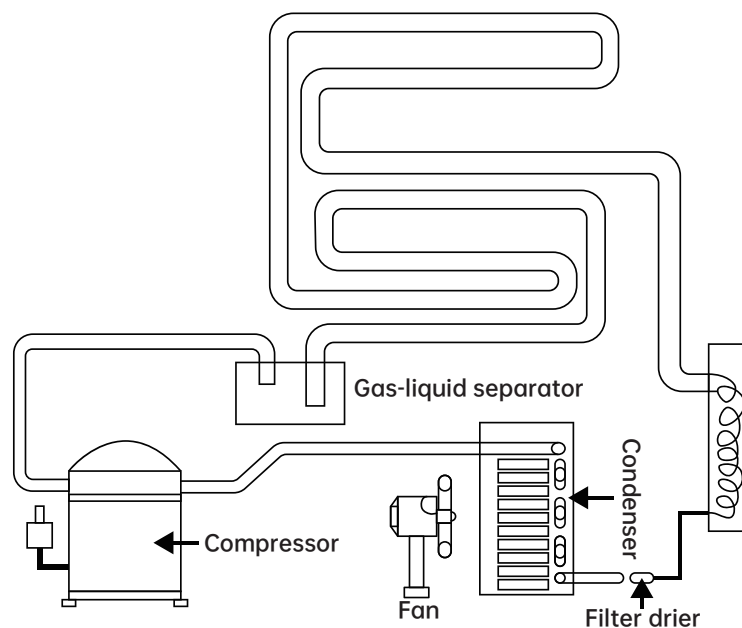

# Control Board Circuit Diagram

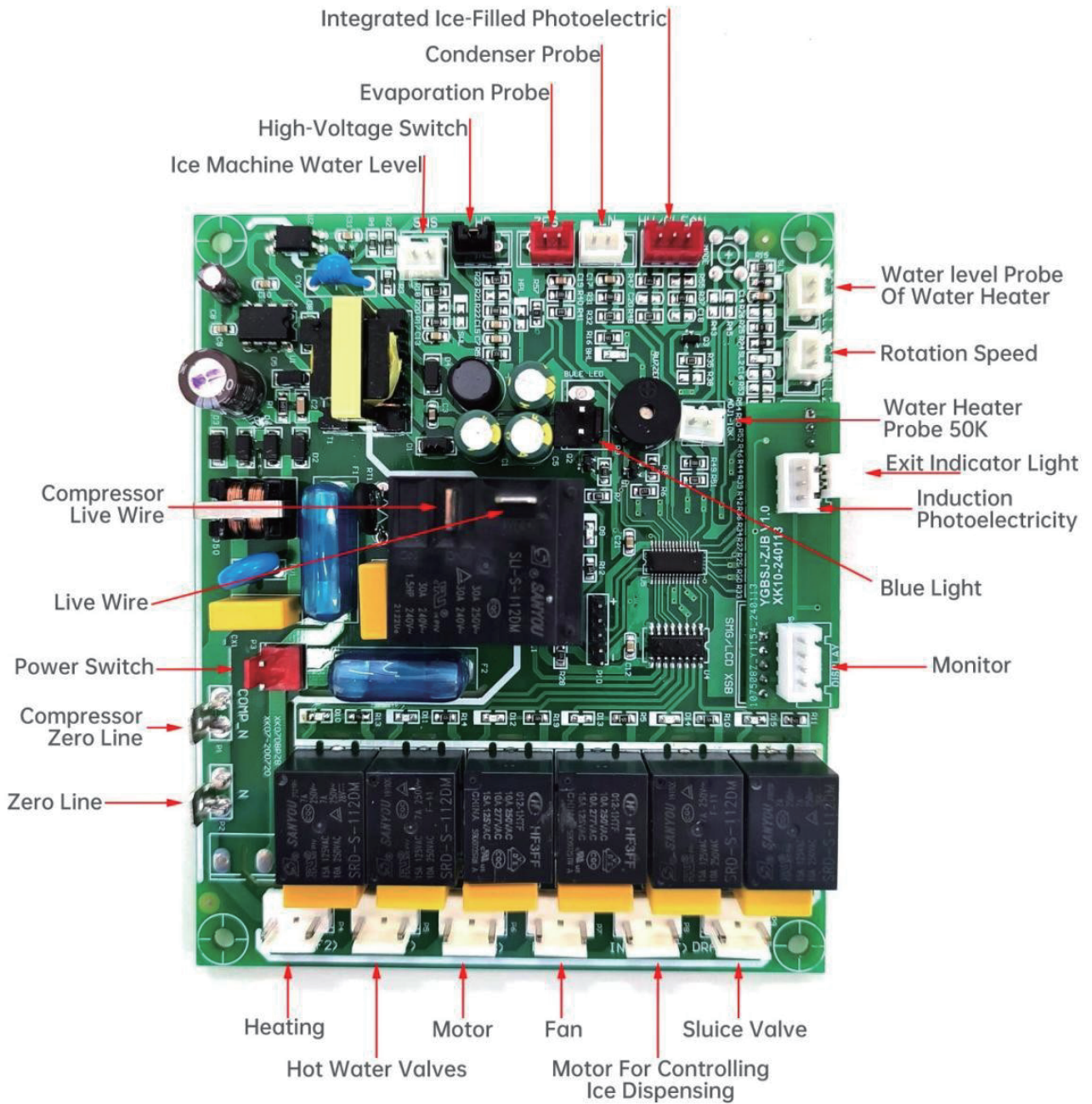

# After-Sales Service Information

## 1. Warranty Period

The product is covered by a one-year warranty from the date of purchase, with a valid warranty record card (stamped by the company and distributor).

## 2. Exclusions from Warranty

The following situations are not covered under the warranty:

Routine maintenance, such as cleaning the condenser, water tank, and refrigerator compartment.

Damage caused by improper use or incorrect storage methods.

Unauthorized modifications to the ice machine structure or damage caused by non-professional repairs.

Damage resulting from incorrect installation of power supply, water supply, or drainage, as well as damage caused by force majeure.

Imported compressors.

## 3. Fault Reporting

In case of a malfunction, please notify the after-sales department or the authorized distributor of our company for service arrangements.

## 4. Maintenance Notice

To ensure continuous and stable operation, clean the condenser fins and water tank every 15 days to remove scale buildup.

Failures caused by dust or scale accumulation on the condenser surface are not covered by the warranty.

# Troubleshooting: Common Faults and Solutions

## Common fault handling:

The following table lists possible failures, their causes and treatment methods. If you can't eliminate the fault according to the method in the table, please find a professional to repair it immediately, and never deal with it hastily, so as not to cause unnecessary losses.

## 2:Setting Item Description

Fault	Reason	Treatment
The ice machine doesn't work	Circuit fault	Check the circuit power supply
	The water inlet pipe is not smooth, there is no water in the sink, and the water level lamp 3 lights up (water)	Check the water source, whether the floating ball is flexible and whether the water inlet hole is blocked
	Whether the ambient temperature and water temperature are too high, the condensing fan is damaged or stuck, and the condenser is too dirty	Ventilate the heat, reduce the ambient temperature and water temperature, repair or replace the motor, wash the condenser
	Ice Rotating Motor Fault, Fault Lamp 5 lights up (ERRD)	Replace ice rotary motor or ice rotary sensor
	Compressor failure	Detection circuit
	Control circuit board failure	Replace or repair control panel
	Refrigerant leakage	Leak detection and refrigerant refilling
The sink overflowed	The water used for ice making is steamed water or electric ions, and the water level lamp 3 lights up (WAIER)	Switch to mineral-containing water sources
	The water level float is broken or stuck	Repair or replace
	The water pressure is too high	Adjust water valve
The ice particles are too wet	The fan is stuck or broken	Repair or replace
	The ambient temperature is too high and the condenser is too dirty	Ventilate, dissipate heat or remove dust
	Excessive overflow	Reduce water overflow
Ice particles have peculiar smell	Excessive water and salt content	Purify water quality
	There are many impurities and peculiar smell in the water inlet	Install water quality filter
Noise anomaly	The water tank is too dirty, and the refrigerator is too dirty	Wash
	Uneven placement	Level four feet
	Loose installation snail	Check and tighten
	Gear damage of ice rotary motor	Replace the motor
	There are foreign bodies on the blades	Remove foreign matter

## Random attachments

Manual×1; 2. Inlet pipe×1; 3. Drain pipe×1; 4. Filter×1