











# ASSEMBLY INSTRUCTIONS

Before you begin, please follow assembly instructions carefully, then follow them step by step.

Read instruction carefully . See Furniture Parts list and Hardware List for guidance . Be sure you have all parts before you start assembling . Place and assemble furniture on a clean flat soft surface , such as carpet or rug to prevent being scratched .

PART LIST		QTY
1	TOP PANEL	1 PC
2	BOTTOM PANEL	1 PC
3	SIDE PANEL (L)	1 PC
4	SIDE PANEL (R)	1 PC
5	CENTER PANEL (L)	1 PC
6	CENTER PANEL (R)	1 PC
7	SHELF PANEL	2 PCS
8	BACK PANEL	1 PC
9	DOOR PANEL	1 PC

HARDWARE			
A	MINI FIX	A1  A2  A3 	8 SETS
B	M8 X 30MM WOOD DOWEL		16 PCS
C	M6 X 50MM CSK CAP WOOD SCREW		8 PCS
D	ALLEN KEY M4		1 PC
E	M3.5 X 16MM C.B SCREW		28 PCS
F	5/8 NAIL		28 PCS
G	METAL SHELF SUPPORT		8 PCS
H	7/8 HINGES		2 PCS
I	PVC SQUARE LEG 5038		5 PCS

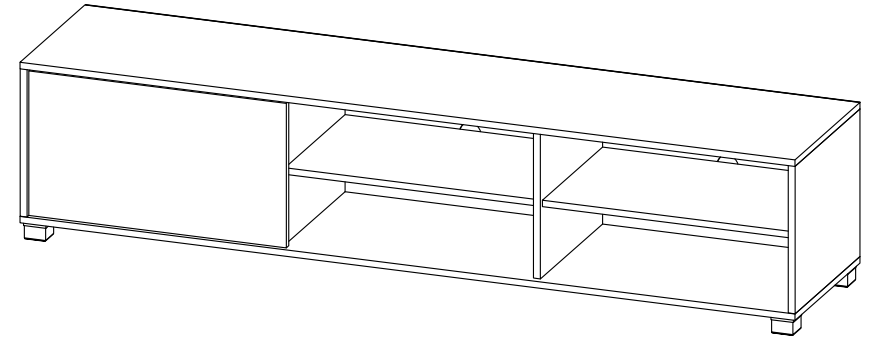

**SELF-PREPARED TOOLS:** Tools below are NOT included in package.



SCREWDRIVER



HAMMER

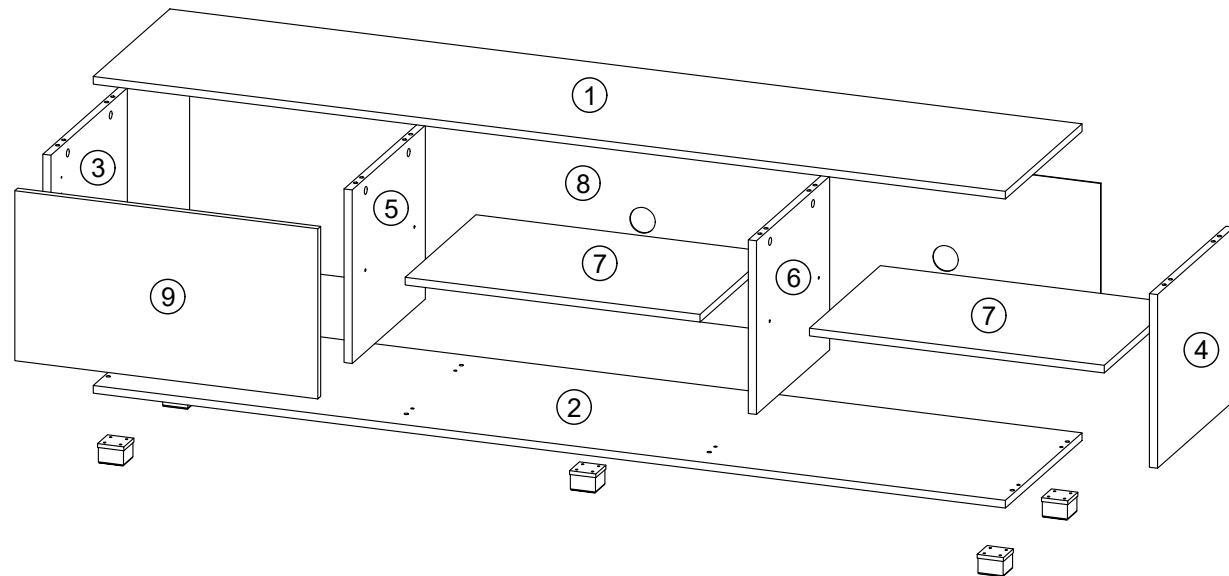

## Reminder:

Please ensure that all surfaces and edges with colours/laminations are facing forward/outward.

# ASSEMBLY INSTRUCTIONS

## STEP 1

Insert hardware **A2** onto panel **(1)**.  
(Repeat 8 times.)

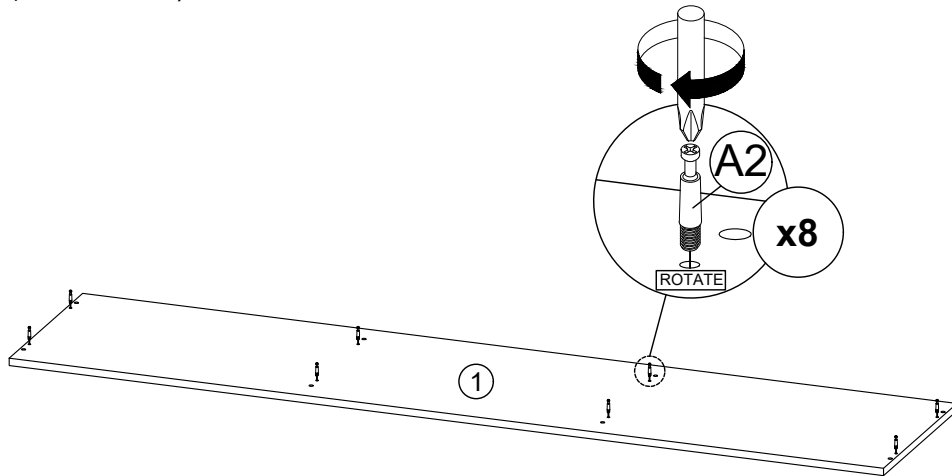

## STEP 2

- Insert hardware **A1** onto panel **(3)** and **(4)**.  
(Repeat 4 times.)  
- Insert hardware **B** onto panel **(3)** and **(4)**.  
(Repeat 8 times.)

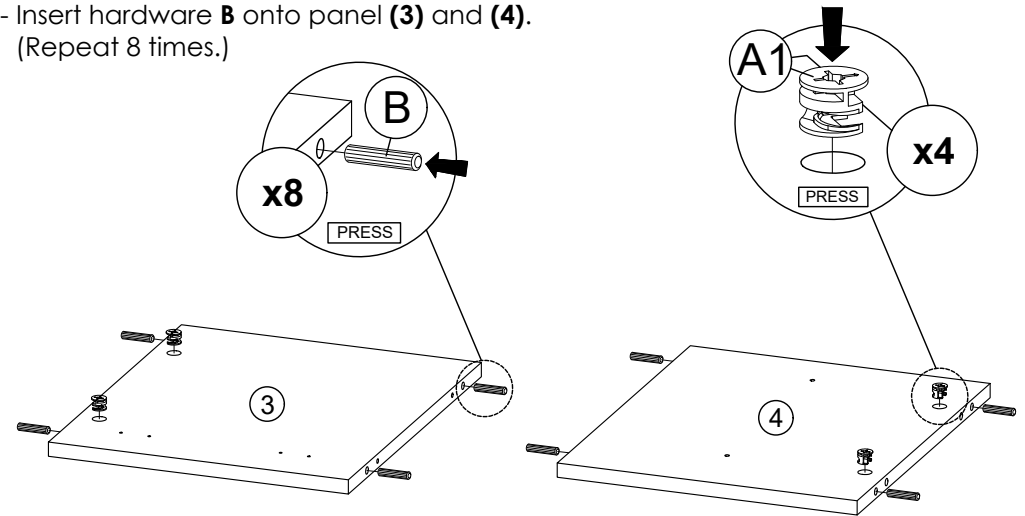

\* Ensure the arrows on hardware **A1** point towards mounting positions.

## STEP 3

- Insert hardware **A1** onto panel **(5)** and **(6)**.  
(Repeat 4 times.)  
- Insert hardware **B** onto panel **(5)** and **(6)**.  
(Repeat 8 times.)

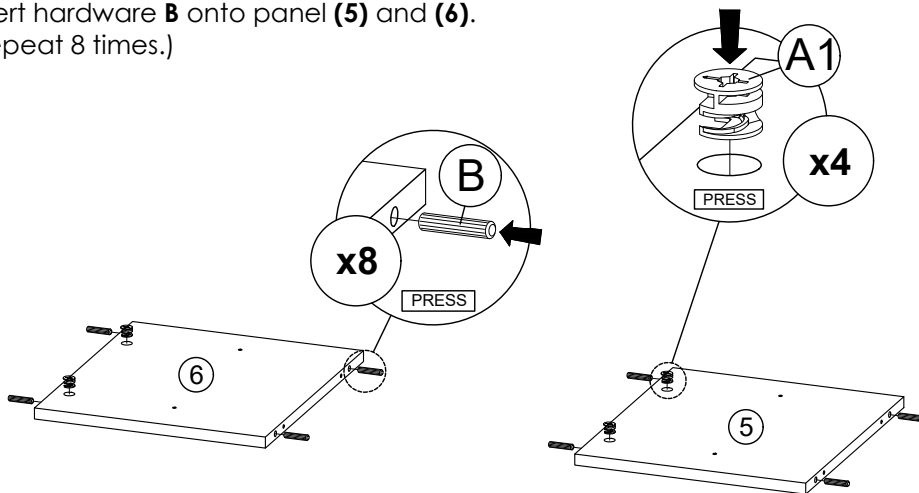

\* Ensure the arrows on hardware **A1** point towards mounting positions.

## STEP 4

- Attach panel **(3)**, **(4)**, **(5)** and **(6)** to panel **(1)**.  
- Insert all hardware **A2** into **A1**.  
- Rotate all **A1** until tight.  
- Apply **A3** onto all **A1**.  
(Repeat 8 times.)



OR

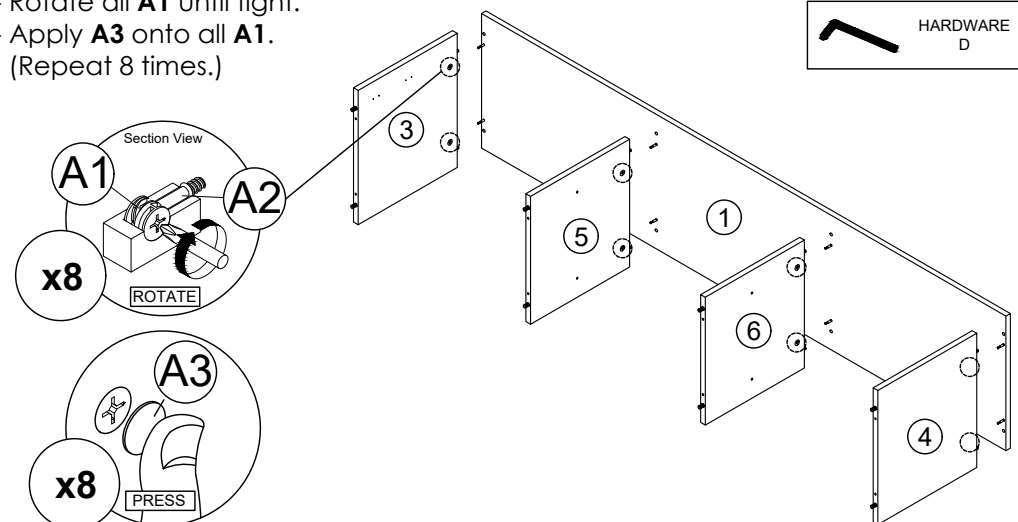

# ASSEMBLY INSTRUCTIONS

## STEP 5

Connect panel **(2)** to panel **(3)**, **(4)**, **(5)** and **(6)** by using hardware **C** and **D**.  
(Repeat 8 times.)

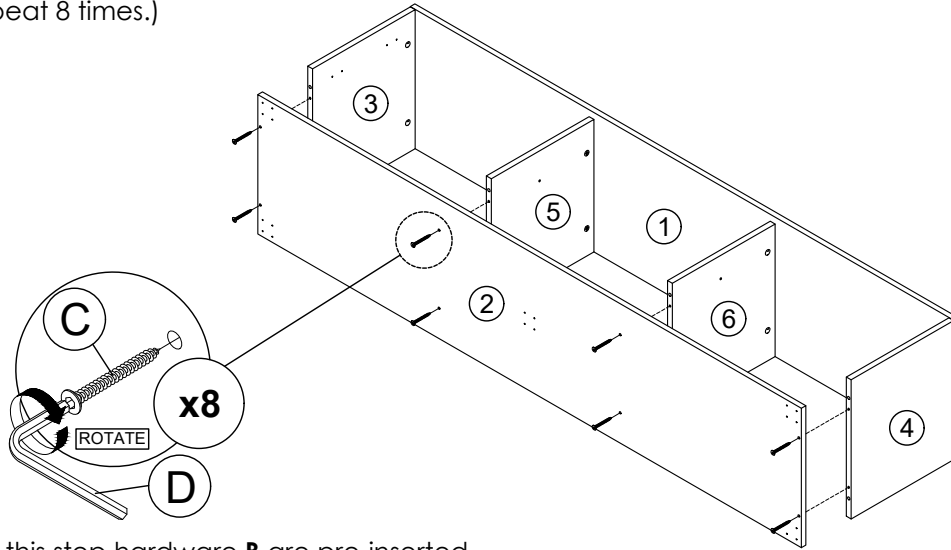

\* In this step hardware **B** are pre-inserted.

## STEP 6

- Fix hardware **I** into panel **(2)** with hardware **E**.  
( Repeat 4 times for each hardware.)  
- Cover back the hardware **I**.  
( Repeat 5 Times )

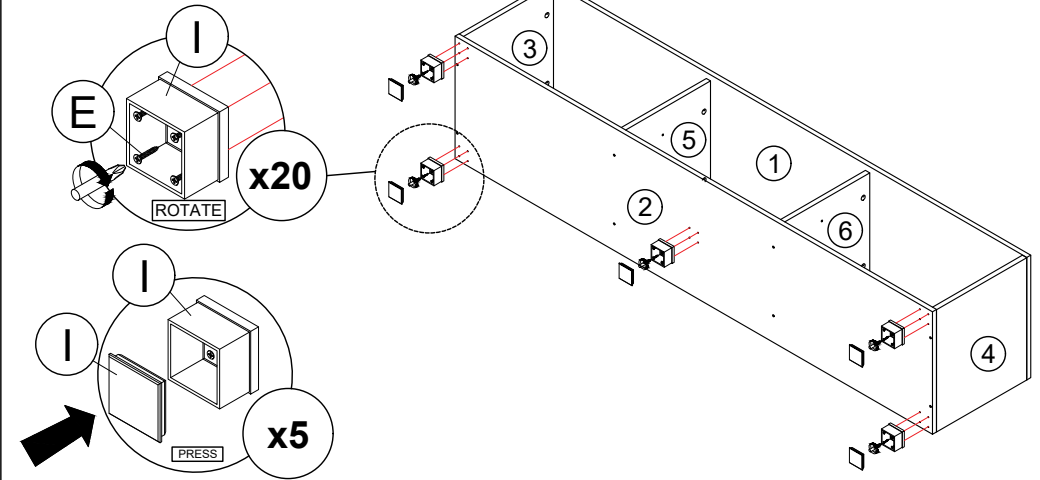

## STEP 7

Assemble panel **(8)** to entire body with hardware **F**.  
(Repeat 28 times.)

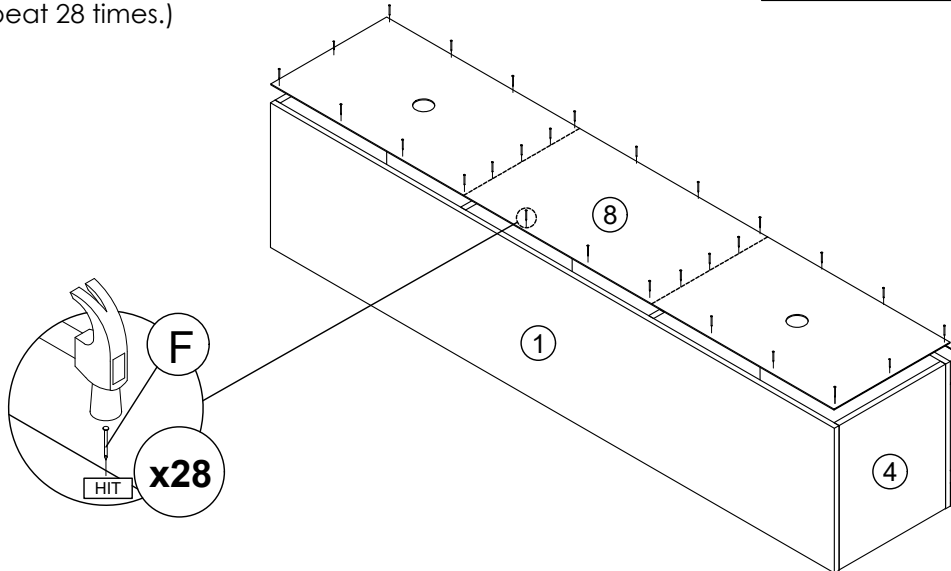

## STEP 8

Insert hardware **G** into mounting positions on panel **(4)**, **(5)** and **(6)** by hand.  
(Repeat 8 times.)

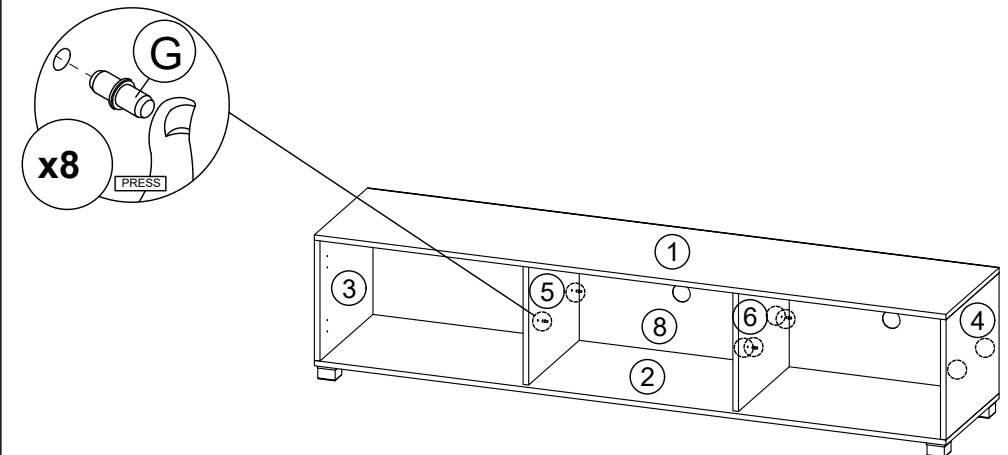

# ASSEMBLY INSTRUCTIONS

## STEP 9

- Assemble the panel (7) into between panel (4) and (6). (Repeat 1 times.)
- Assemble the panel (7) into between panel (5) and (6). (Repeat 1 times.)

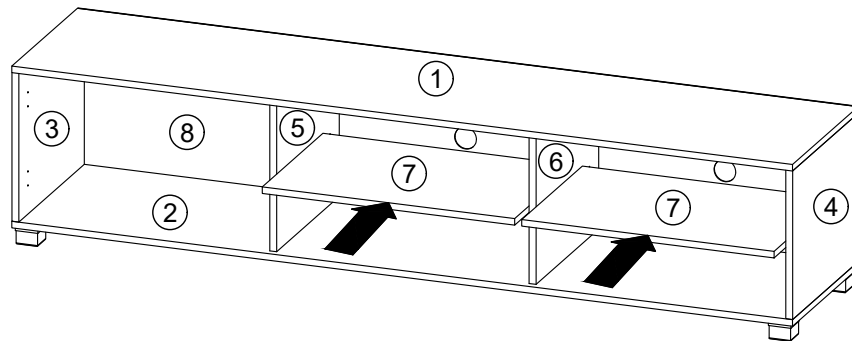

\* In this step hardware **G** are pre-inserted.

## STEP 10

- Fix hardware **H** onto panel (9) by using hardware **E**. (Repeat 2 times for each hardware.)

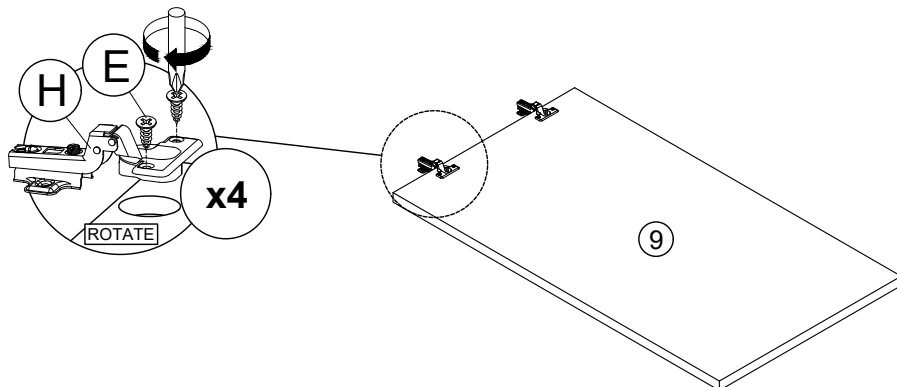

## STEP 11

- Fix hardware **H** into panel (3) by using hardware **E**. (Repeat 2 times for each hardware.)
- Tighten or loosen the screw to adjust position of panel (9). (Do only when needed.)

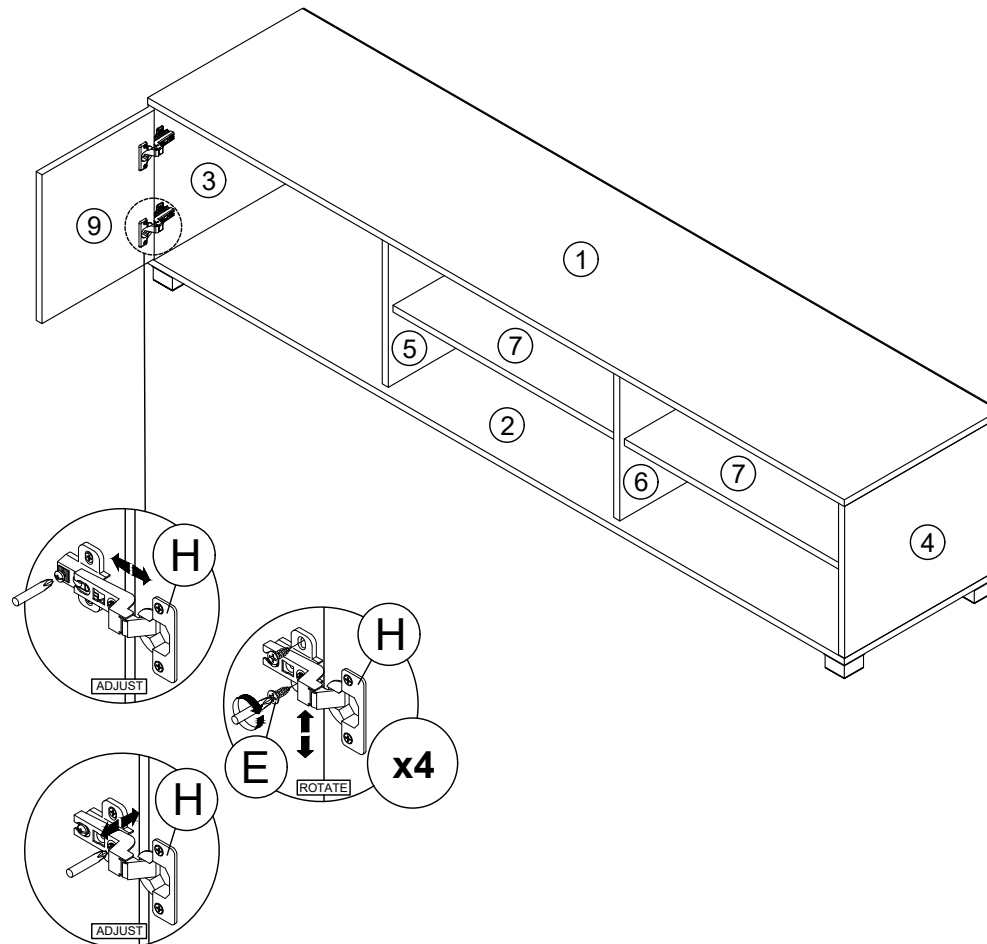

\* In this step hardware **H** have been assembled in panel (9).