

# ASSEMBLY INSTRUCTIONS

## CURVES BACK 30" METAL BAR STOOL



### **We are here to help!**

We do our best to insure that your furniture arrives in excellent condition. In the event that a part is damaged or missing, we will be happy to provide you with replacement parts, at no charge, within 30 days of purchase, providing the parts are available in our warehouse and the item purchased is part of our current inventory. In order to receive spare parts, at no charge, you must provide proof of purchase within 30 days.

If you need assistance with assembly or replacement parts, please call Customer Service, prior to returning the item to the store.

Or visit our web site to order spare parts and for care instructions on your newly purchased furniture.

MADE IN CHINA

## Parts Identification

ITEM	DESCRIPTION	QTY
#1	BACK	01
#2	SEAT FRAME	01
#3	SWIVEL	01
#4	TOP SUPPORT RING	01
#5	LEG FRAME	04
#6	BOTTOM SUPPORT RING	01
#7	CUSHION	01

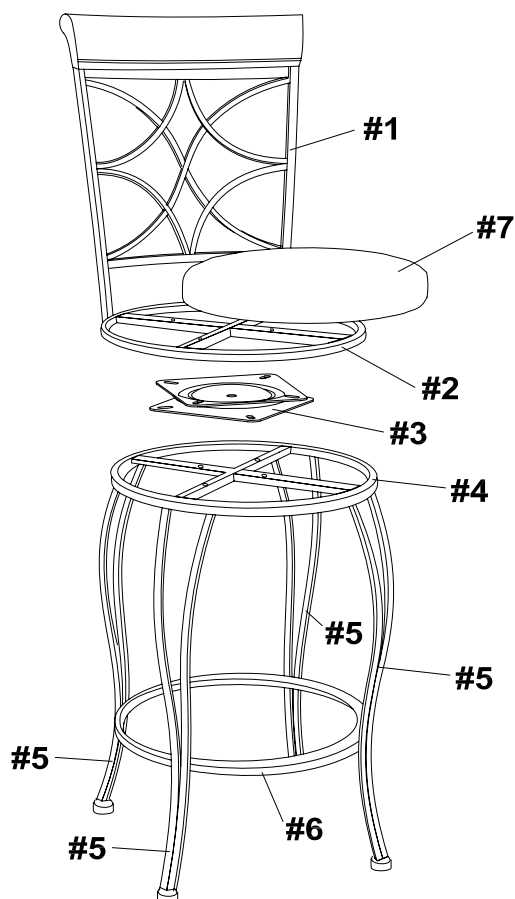





For ease of identification all parts are labeled to correspond to the Step number in which the part is used.

If any parts are missing or damaged in this package, we will be happy to provide you with replacement parts, at no charge, within 30 days of purchase, providing the parts are available in our warehouse and the item purchased is part of our current inventory. In order to receive spare parts, at no charge, you must provide proof of purchase within 30 days.

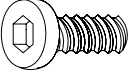
Call us toll free . Or visit our web site to order spare parts and for care instructions on your newly purchased furniture.

## Hardware Identification

ITEM	PICTURE	DESCRIPTION	QTY
<b>A</b>	 (Ø1/4"x15mm)	<b>BOLT</b>	<b>28</b>
<b>B</b>	 (Ø5mmx30mm)	<b>WOOD SCREW</b>	<b>04</b>
<b>C</b>	 (Ø1/4")	<b>FLAT WASHER</b>	<b>28</b>
<b>D</b>	 (Ø1/4")	<b>SPRING WASHER</b>	<b>28</b>
<b>E</b>		<b>HEXAGONAL WRENCH</b>	<b>01</b>

If any parts are missing or damaged in this package, we will be happy to provide you with replacement parts, at no charge, within 30 days of purchase, providing the parts are available in our warehouse and the item purchased is part of our current inventory. In order to receive spare parts, at no charge, you must provide proof of purchase within 30 days.

Call us toll free . Or visit our web site to order spare parts and for care instructions on your newly purchased furniture.

STEP 1.

1-1

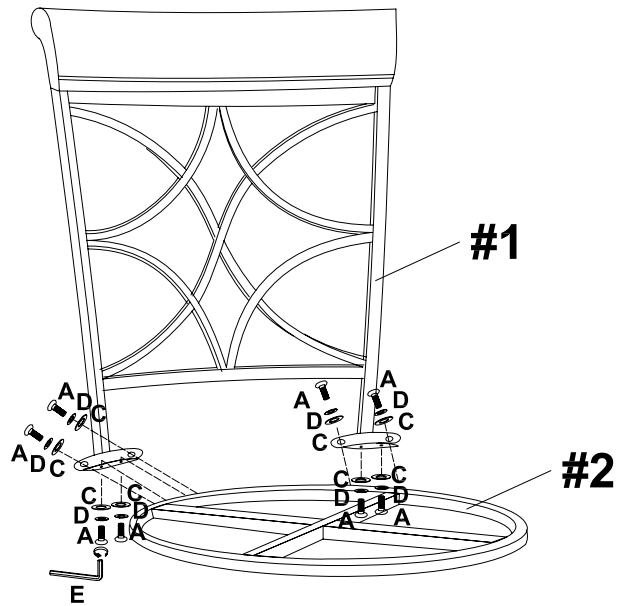

1-2

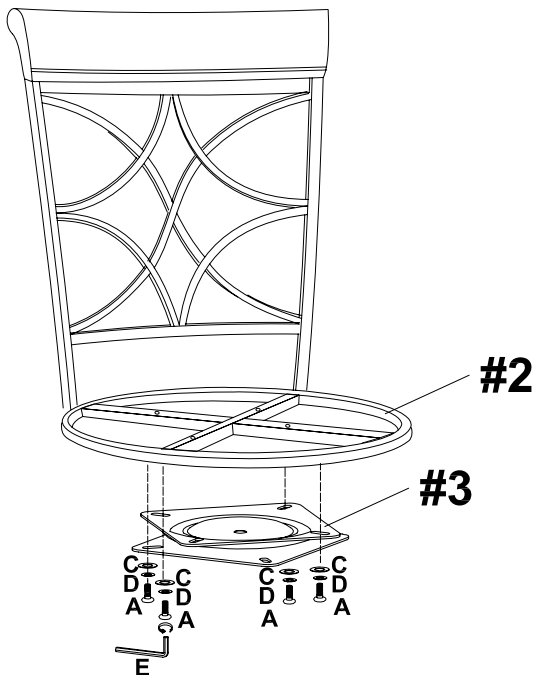

1-3

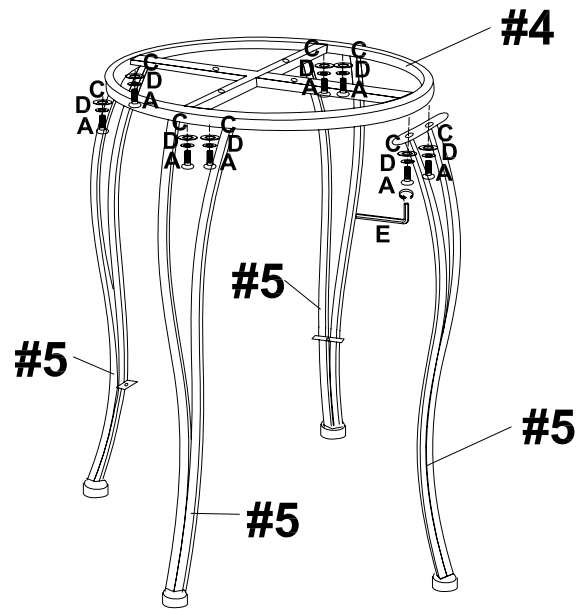

IMPORTANT: DO NOT TIGHTEN COMPLETELY ANY BOLT UNTIL ALL LINED-UP BOLTS ARE CONNECTED TO INSERTED NUTS.

STEP 2.

2-1

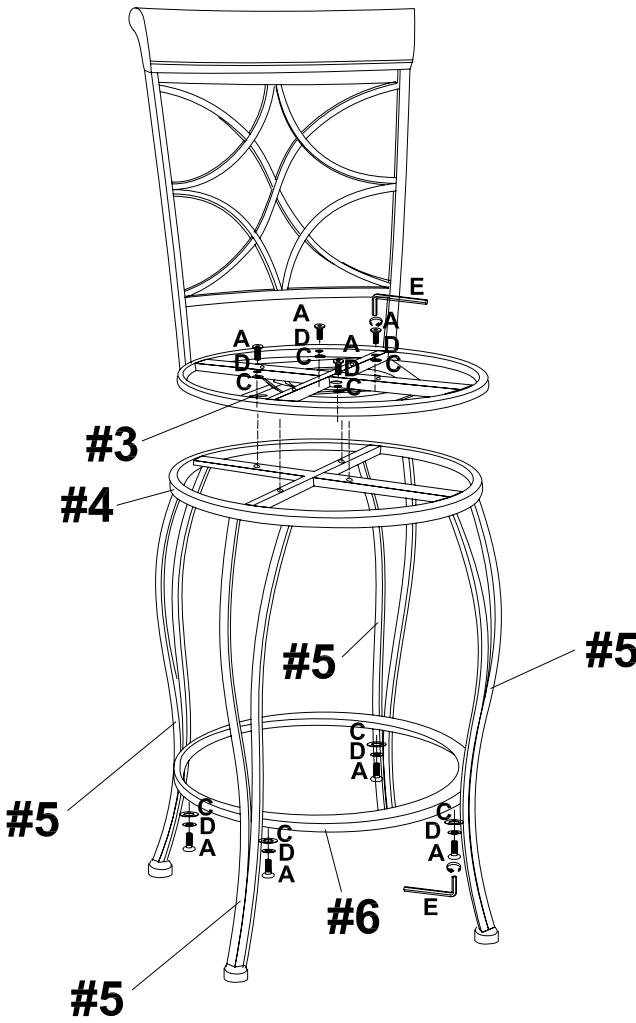

2-2

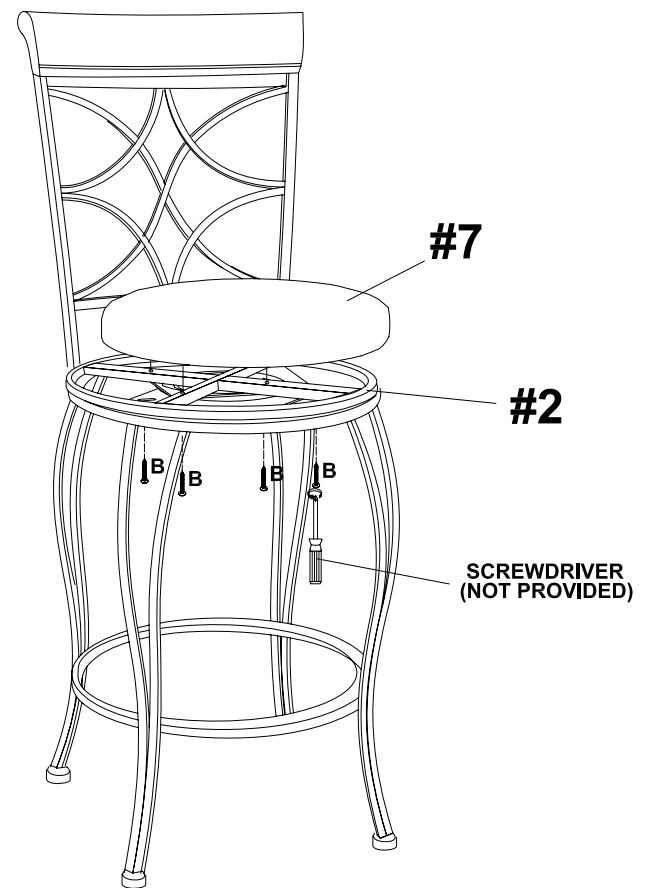

SCREWDRIVER  
(NOT PROVIDED)

# **LIMITED 6 MONTHS WARRANTY**

## **WHAT IS COVERED**

This product is covered under our manufacturer's 6 months limited warranty. To ensure your complete satisfaction, this warrants to the original purchaser that the supplied item is free from defects in material and workmanship, as of the date of purchase, and that it will, under normal use and proper care, remain so for six months after the date of purchase.

Replacement of missing or initially defective parts will be sent, at no charge, for a period of 30 days from the date of purchase with valid proof of purchase providing the parts are available in our warehouse and the item purchased is part of our current inventory.

## **WHAT IS NOT COVERED**

It remains the customer's responsibility for freight and packaging charges to and from the customer service center. Labor and material charges to remove or replace parts under this warranty are not covered.

This warranty does not cover: Furniture used for commercial purposes, failures caused by improper care, unreasonable or abusive use, freeze damage, acts of God, rust, purchased parts or return freight and packaging charges. Proof of purchase (dated register receipt) is required for warranty claims.

## **HOW TO OBTAIN SERVICE**

For further information, please contact our customer service department

Visit our web site to order spare parts and for care instructions on your newly purchased furniture.