

ASSEMBLY INSTRUCTIONS

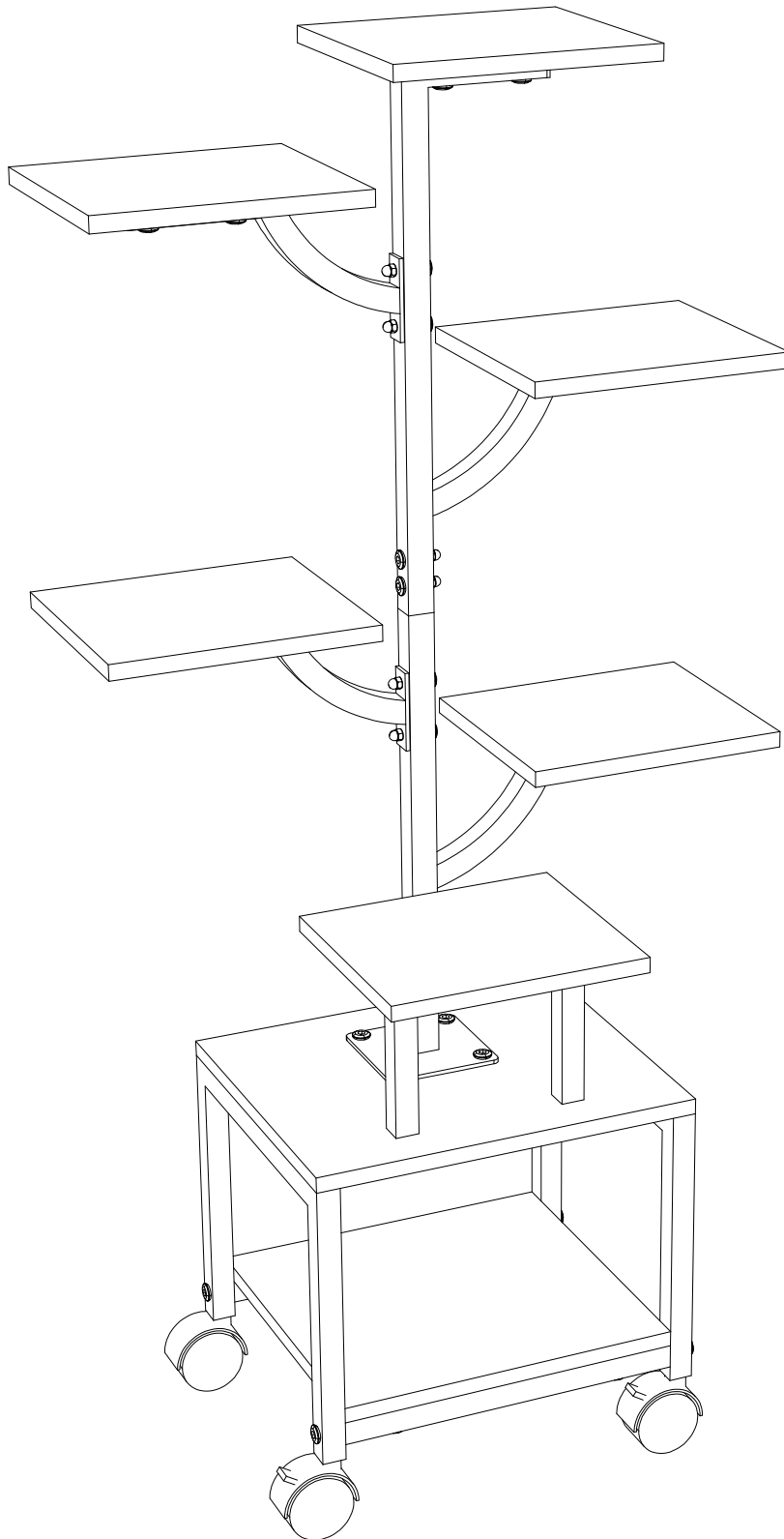

ASSEMBLY OVERVIEW

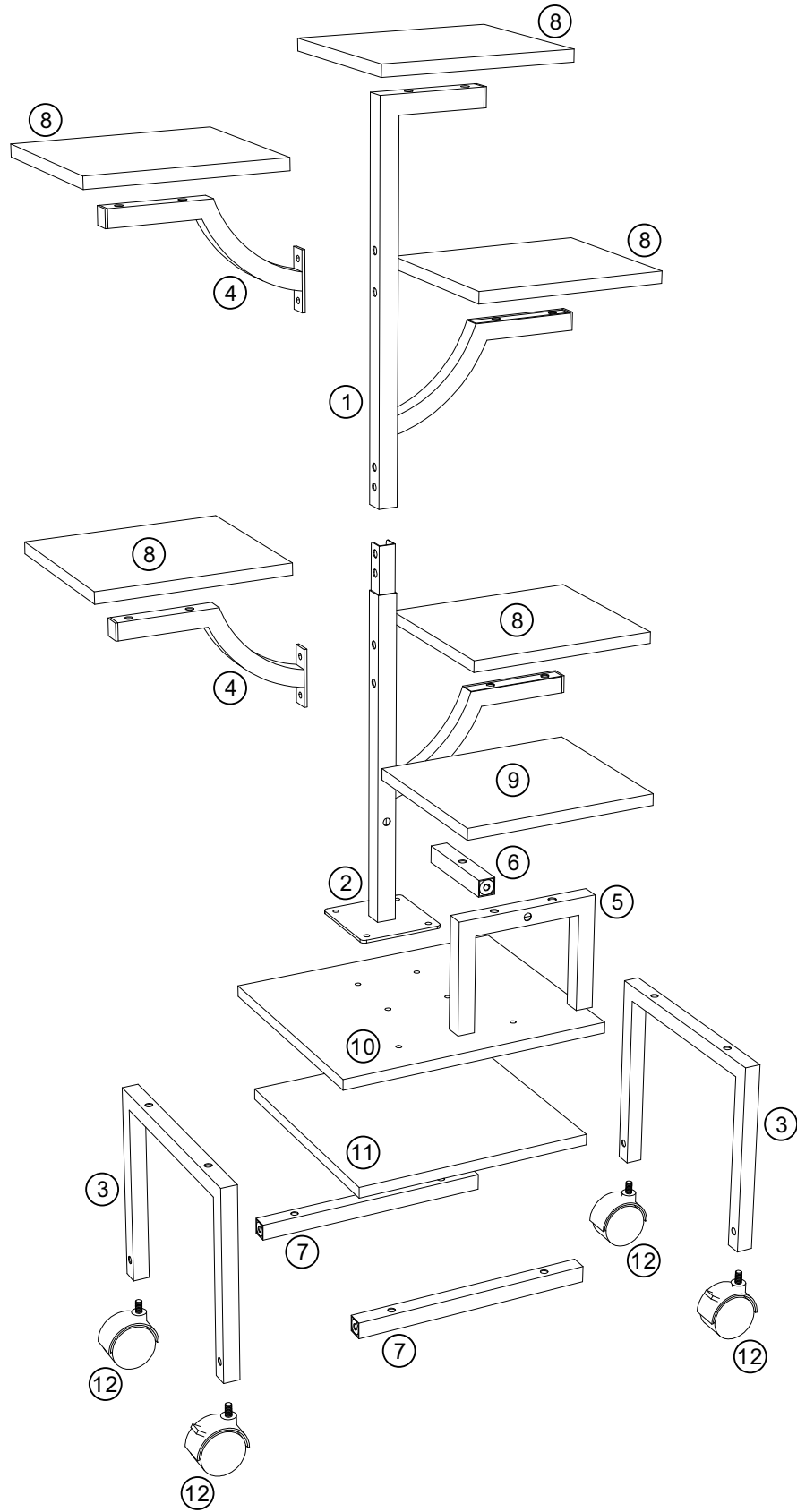

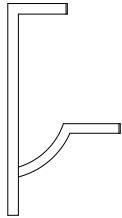
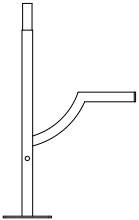
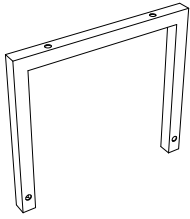
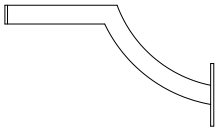
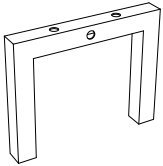

PARTS LIST

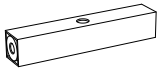
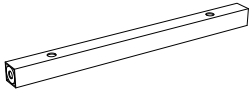
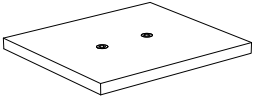
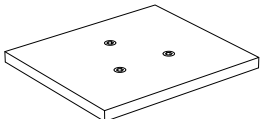
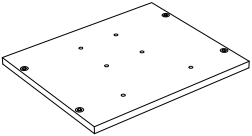
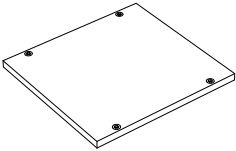
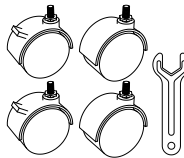
Ref	DESCRIPTON	Visual	Qty
①	Support Frame		1
②	Support Frame		1
③	Connection Rod		2
④	Connection Rod		2
⑤	Connection Rod		1

Ref	DESCRIPTON	Visual	Qty
⑥	Connection Rod		1
⑦	Connection Rod		2
⑧	Support Panel		5
⑨	Support Panel		1
⑩	Support Panel		1
⑪	Support Panel		1
⑫	Caster Wheels		1

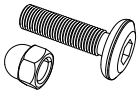
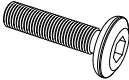
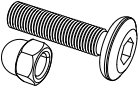
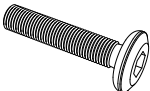
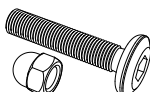
HARDWARE LIST

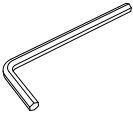
Ref	DESCRIPTON	Visual	Qty	Spare Qty
A	M6x26mm		4	
B	M6x28mm		27	2
C	M6x28mm		2	1
D	M6x33mm		2	
E	M6x33mm		4	

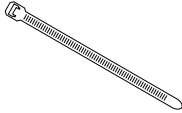
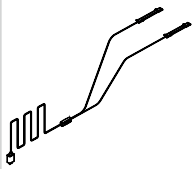
Ref	DESCRIPTON	Visual	Qty	Spare Qty
F	L Wrench		1	
G	Wrench		1	
H	Cable Ties		4	
I	Light Strip		1	

ASSEMBLY INSTRUCTIONS

1

Connect connection rods ⑤ ⑥ and support panel ⑨ by screws (B).
Connect connection rods ⑦ and support panel ⑪ by screws (B).

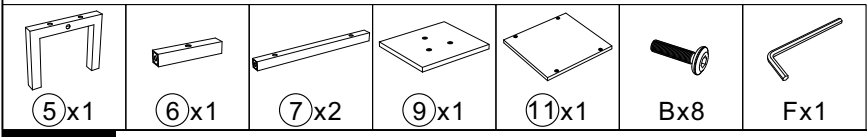
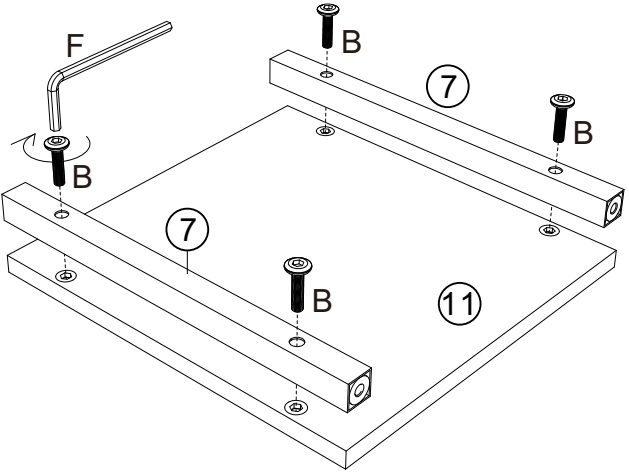
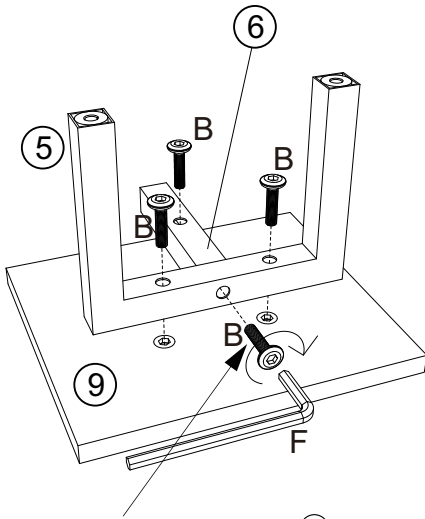

2

Connect support panel ⑩ and connection rods ③ by screws (B).

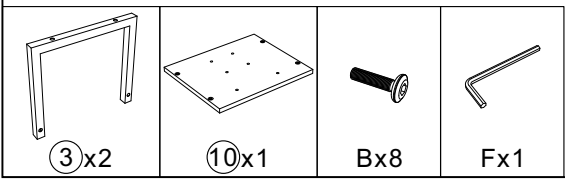
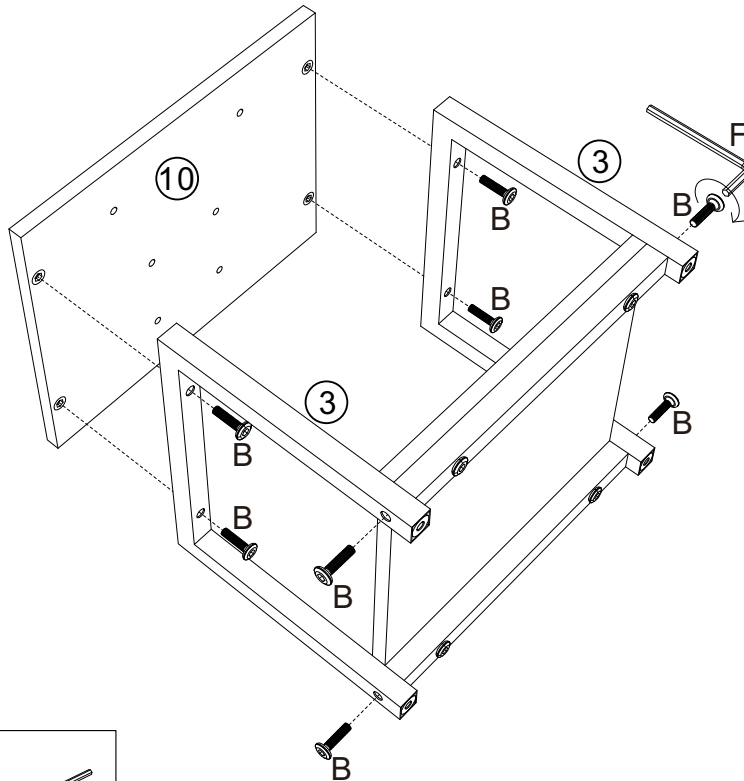

ASSEMBLY INSTRUCTIONS

- 3** Connect support frame ① and connection rod ④ by screws (E).
Connect support frame ② and connection rod ④ by screws (E).

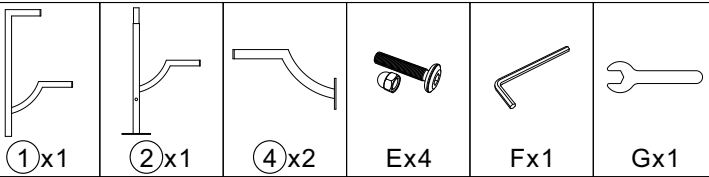
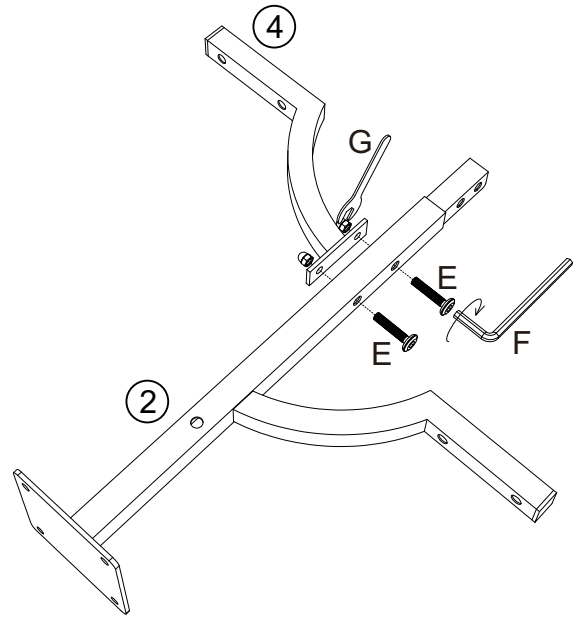
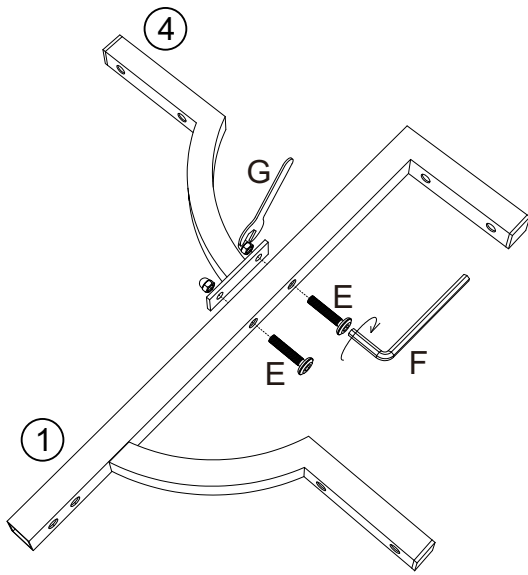

- 4** **Step 1:** Connect support frame ② and support panel ⑩ by screws (A).
Step 2: Connect support frame ① and support frame ② by screws (C).

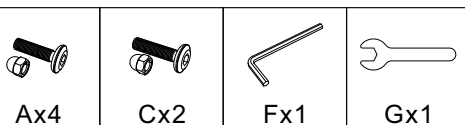
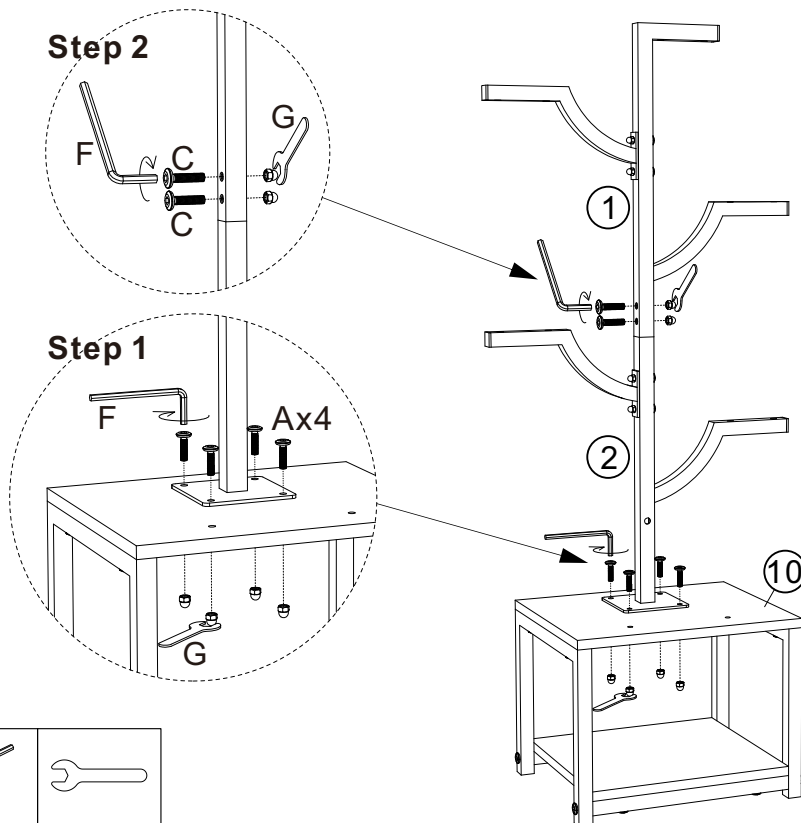

ASSEMBLY INSTRUCTIONS

5 Connect support frame (2) and connection rod (6) by screw (B).

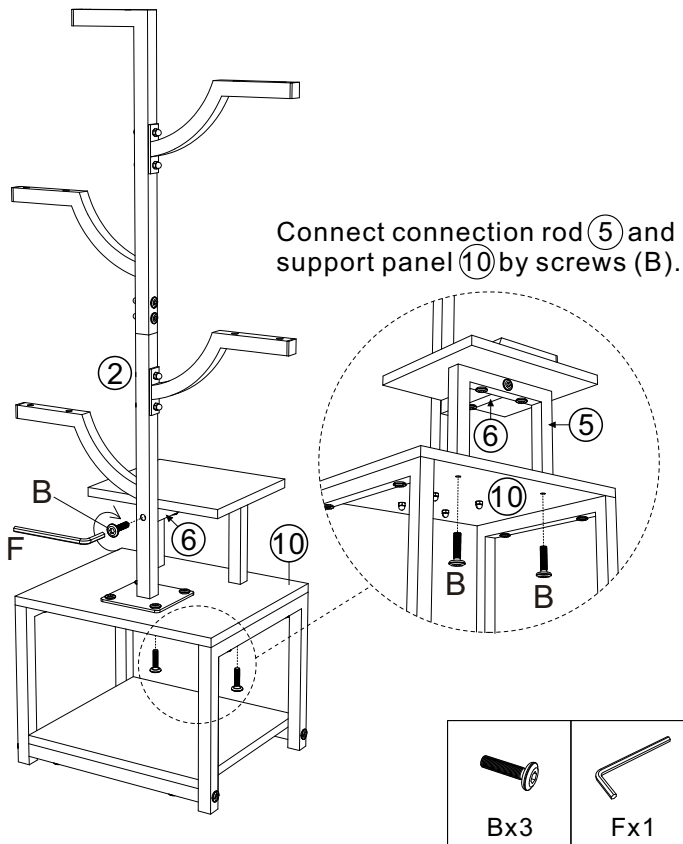

6 Use screws (B) and screws (D) to fix support panels (8) to support frame (1) (2).

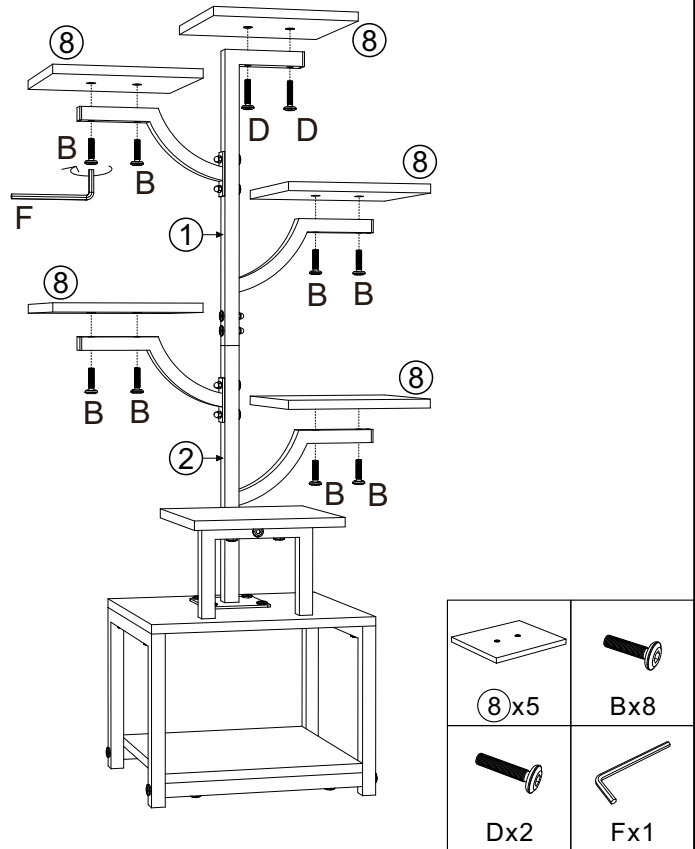

7 Connect connection rods (3) by caster wheels (12).

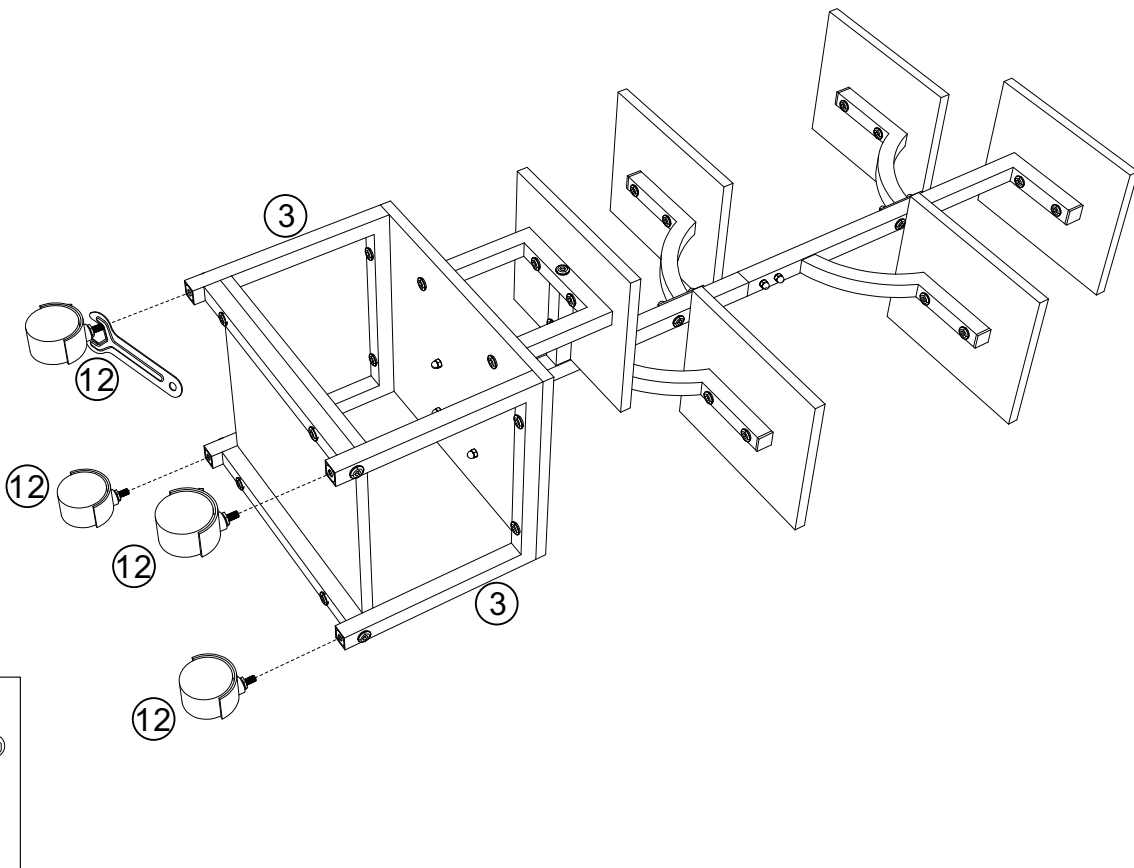

ASSEMBLY INSTRUCTIONS

8

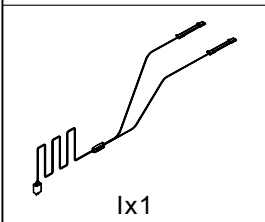
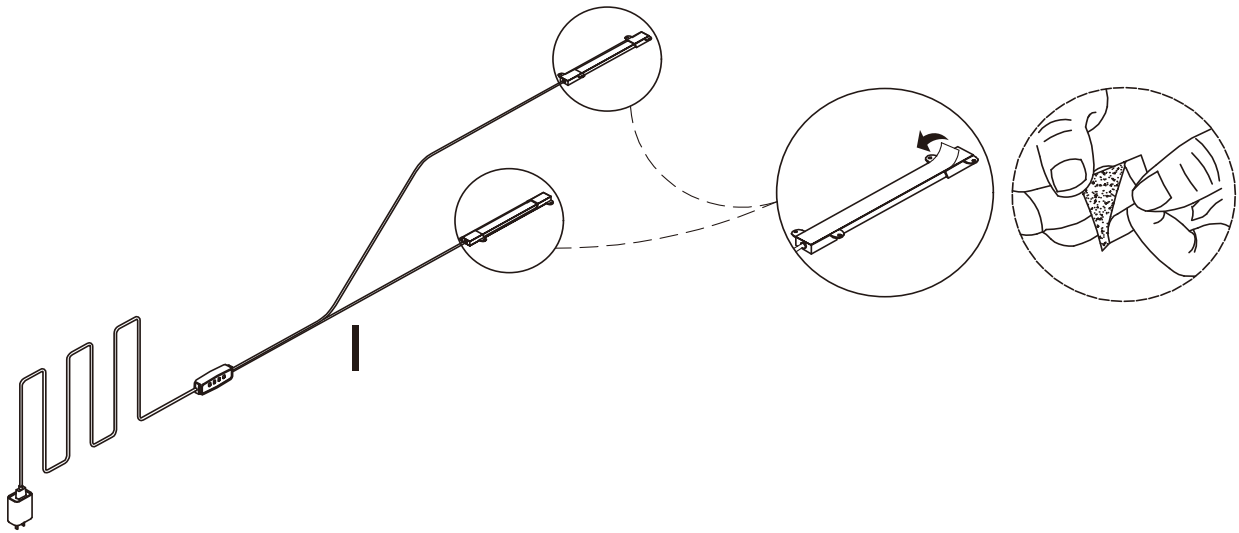

9

