

# MANUAL INSTRUCTION

## Black Flip-door Side Cabinet with 2-drawer

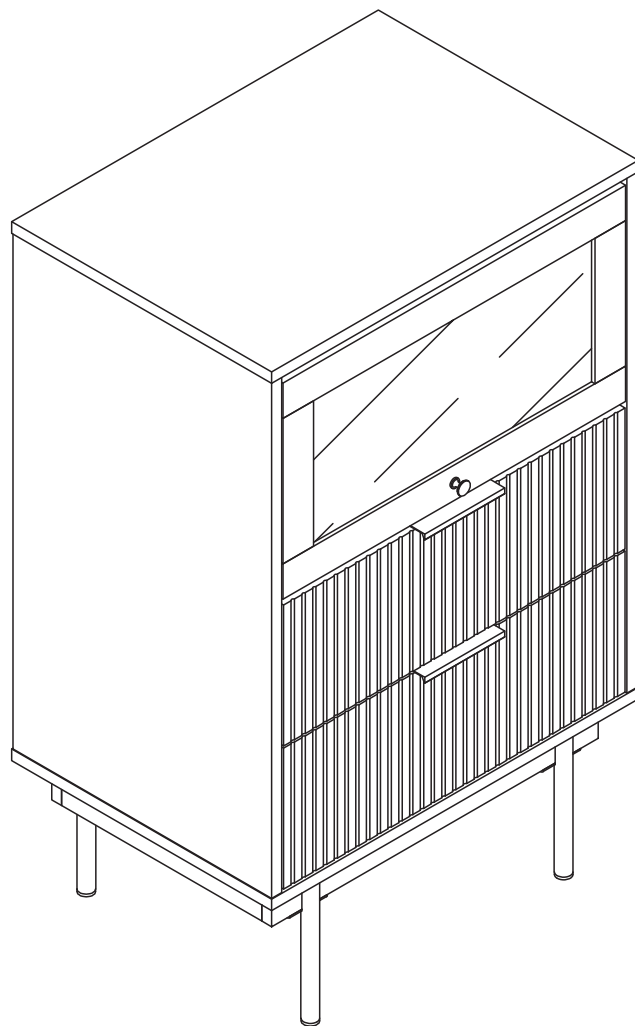

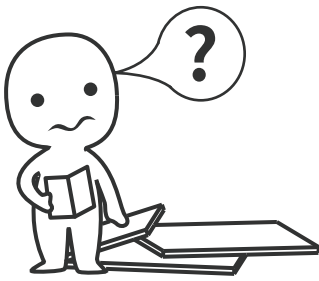

### **IMPORTANT INFORMATION!**

please read the entire manual before starting to assemble and/or using this product. follow the manual thoroughly and keep it for further reference.

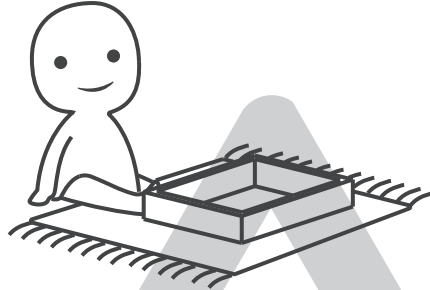
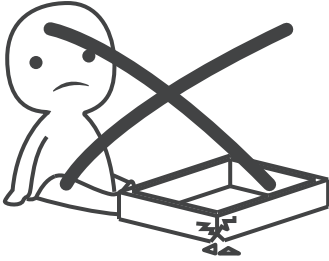

### **AVOID SCRATCHES!**

In order to avoid scratching this furniture should be assembled on a soft layer- could be a rug.

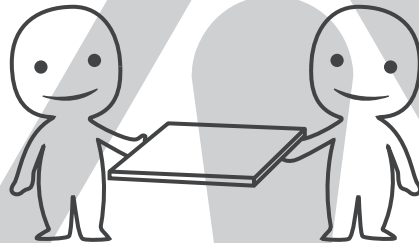

### **IMPROVE EFFICIENCY !**

Try to find a partner to install with you, which can speed up the installation efficiency and shorten the time.

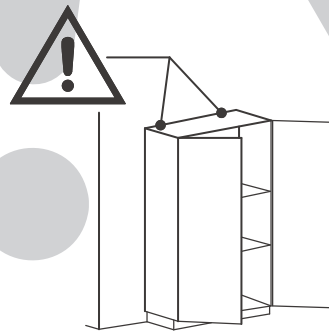
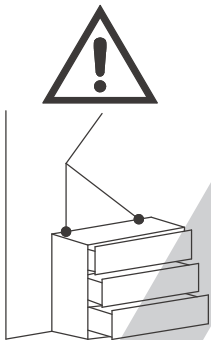

### **ANTI-TOPPLE WARNING !**

Overturned furniture can cause serious or fatal crush injuries. To prevent tipping over, be sure to use the wall attachment, if not included with this product. Please purchase the wall attachment that fit your wall. If unsure, seek professional advice. Please read and follow each step of the instructions carefully.

### **IMPORTANT !**

It is important that any product which is assembled using any kind of screw is re-tightened 2 weeks after assembly, and once every 3 months - in order to assure stability through-out the lifespan of the product.

For regular maintenance and cleaning of the product, for the frame, please use a rag dipped in neutral detergent to fully wipe it, and then dry it with a clean rag. For glass materials, wipe with a rag dampened with water glass cleaner, and then dry with a dry rag.

Do not use an electric screwdriver, and do not use too much force when installing, because the board is easy to break.

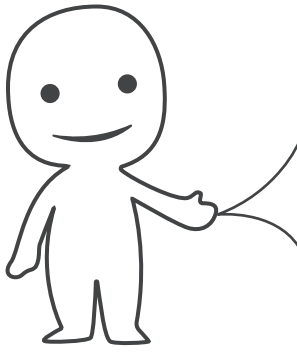



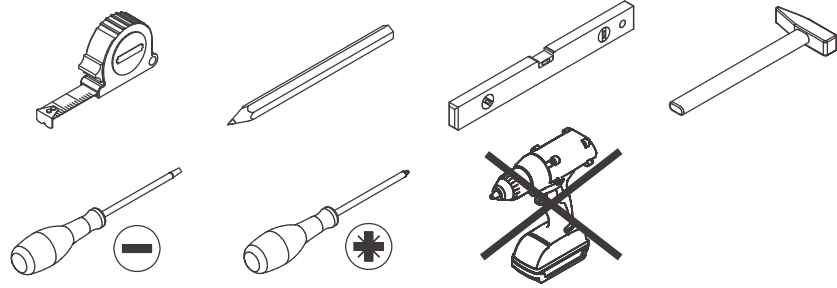















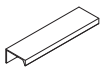
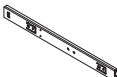

Please prepare the following tools



When installing, please carefully confirm whether each screw corresponds to the manual, accessories with similar shapes can be distinguished by size

## I HARDWARE

 A×20	 B×20	 C×16 6×30mm	 D×12 4×35mm	 E×8 4×45mm
 F×32 3×12mm	 G×14 3×14mm	 H×9 4×12mm	 I×1	 J×1 4×16mm
 K×2	 L×4	 M×16 6×12mm	 N×1	 O×2
 P×8	 Q×2	 R×1	 S×1 4×35mm	 T×1
 U×3				

# I PARTS

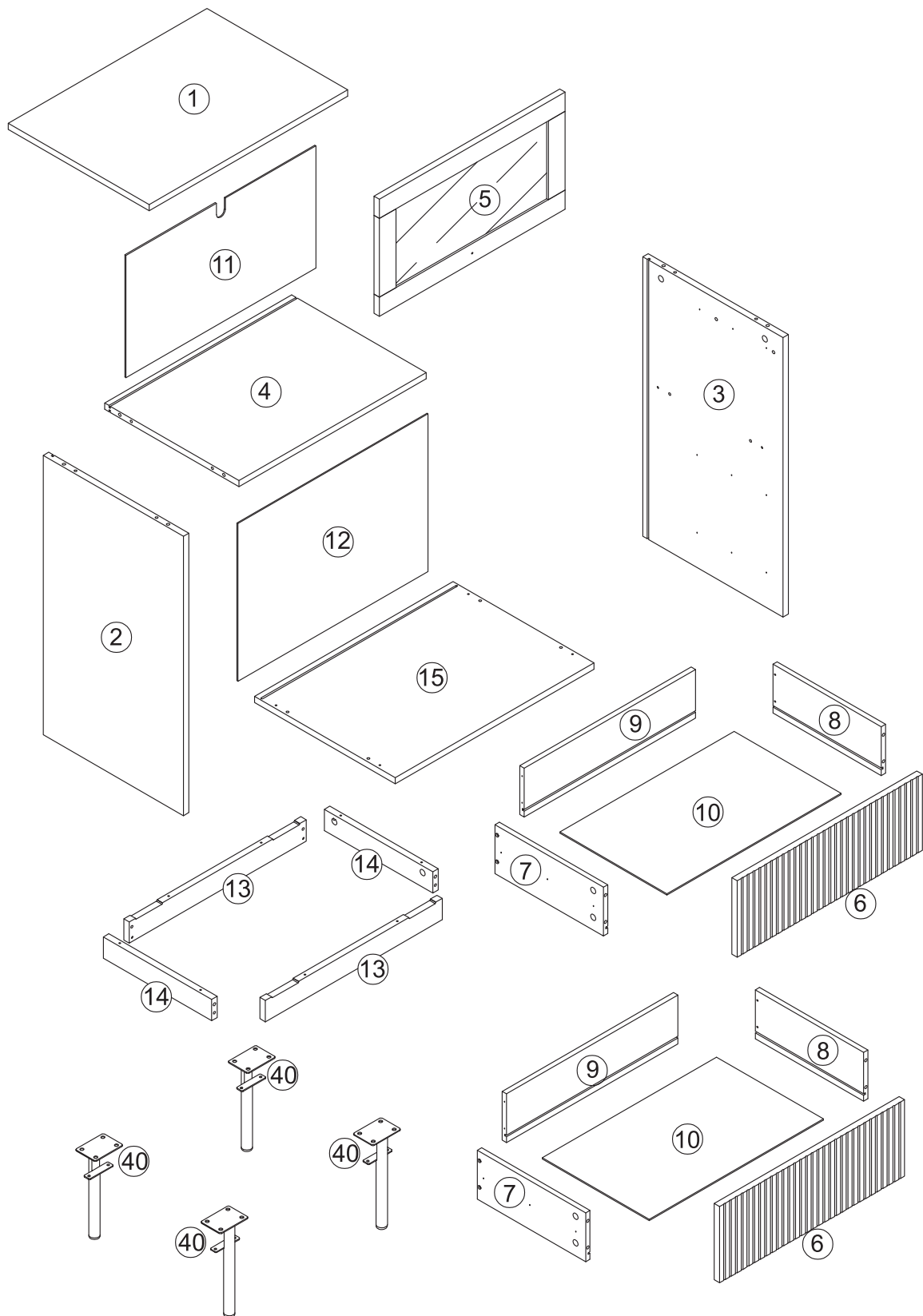

# I PRODUCT ASSEMBLY

1

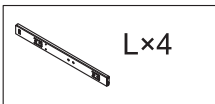
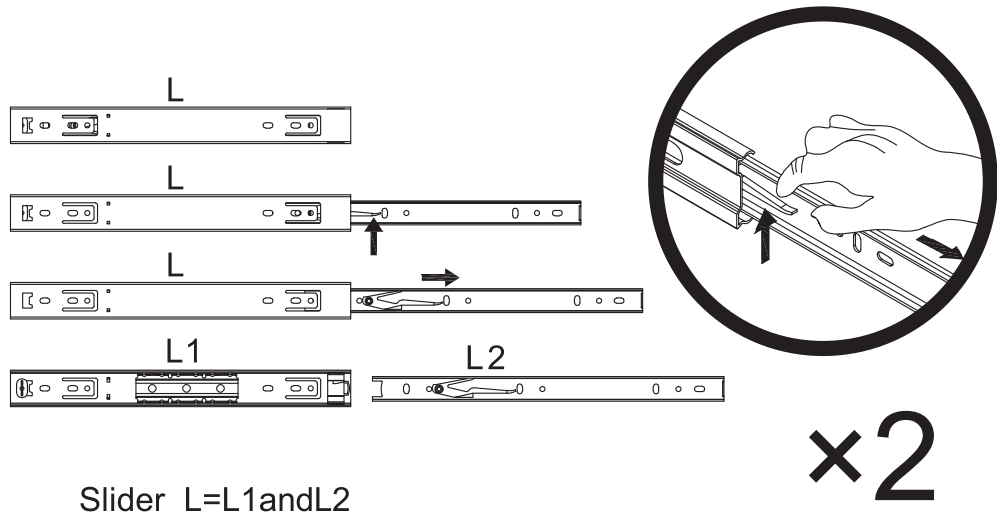

2

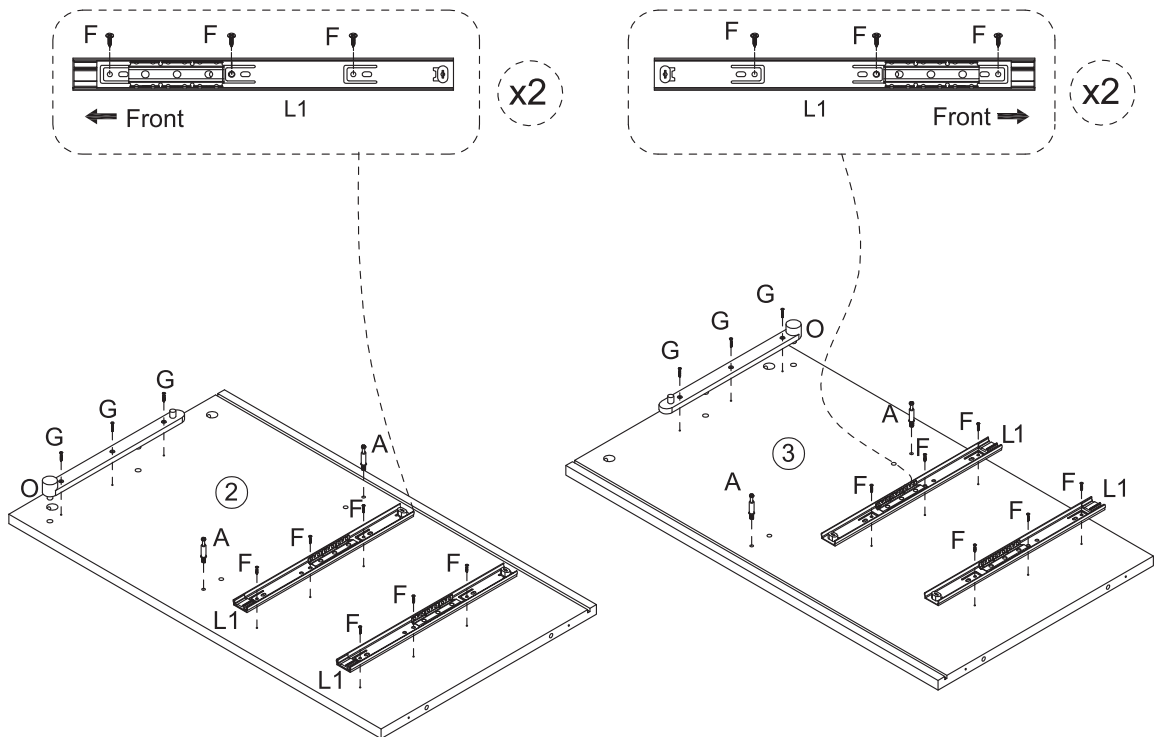

 Ax4	 Fx12	 Gx6	 L1x4	 Ox2
-----------------------------------------------------------------------------------------	------------------------------------------------------------------------------------------	-----------------------------------------------------------------------------------------	------------------------------------------------------------------------------------------	-----------------------------------------------------------------------------------------

# I PRODUCT ASSEMBLY



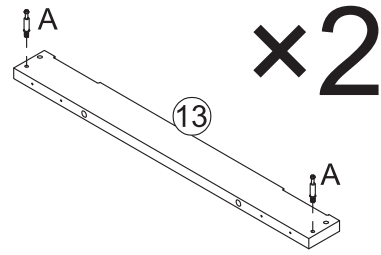
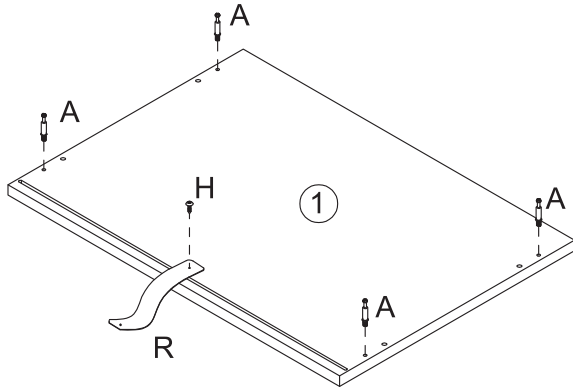

3

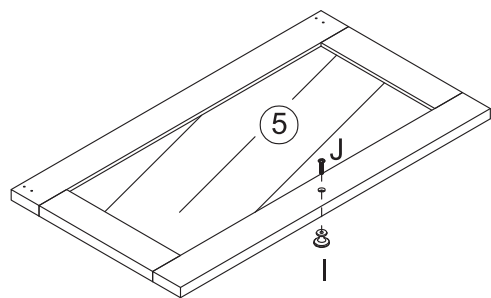
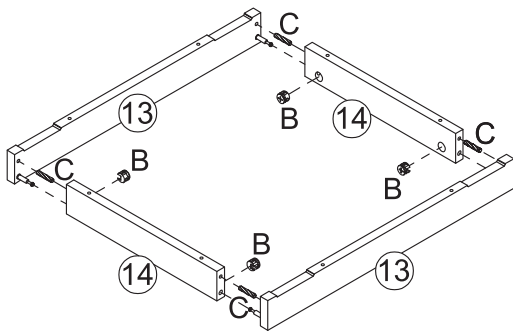

 A×8	 H×1	 R×1
-----------------------------------------------------------------------------------------	-----------------------------------------------------------------------------------------	-----------------------------------------------------------------------------------------

4



 B×4	 C×4	 I×1	 J×1
-----------------------------------------------------------------------------------------	-----------------------------------------------------------------------------------------	-----------------------------------------------------------------------------------------	-----------------------------------------------------------------------------------------

# I PRODUCT ASSEMBLY

5

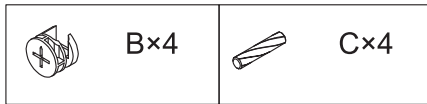
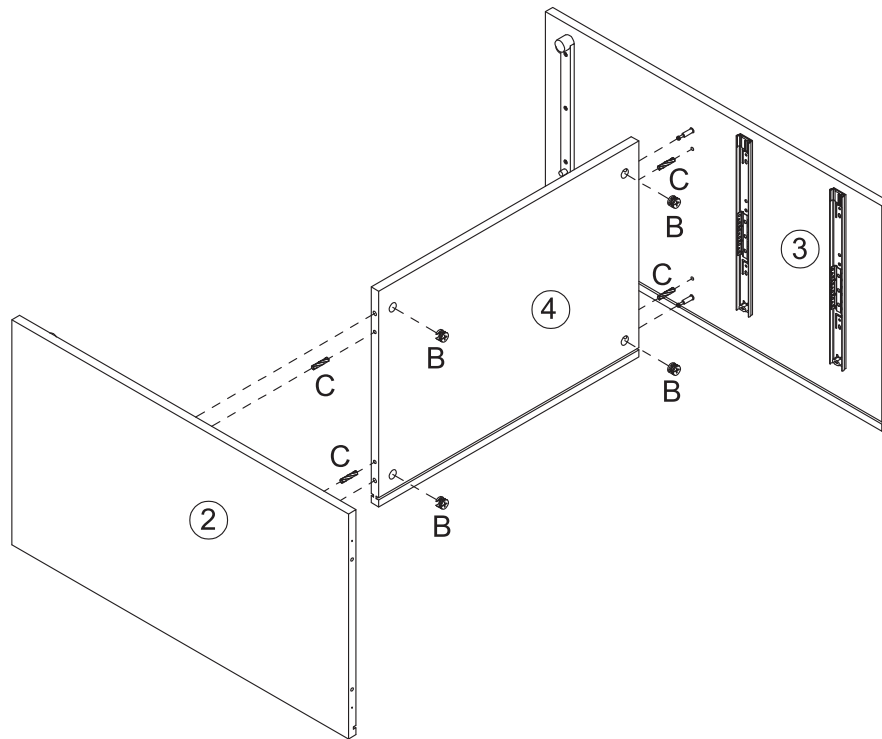

6

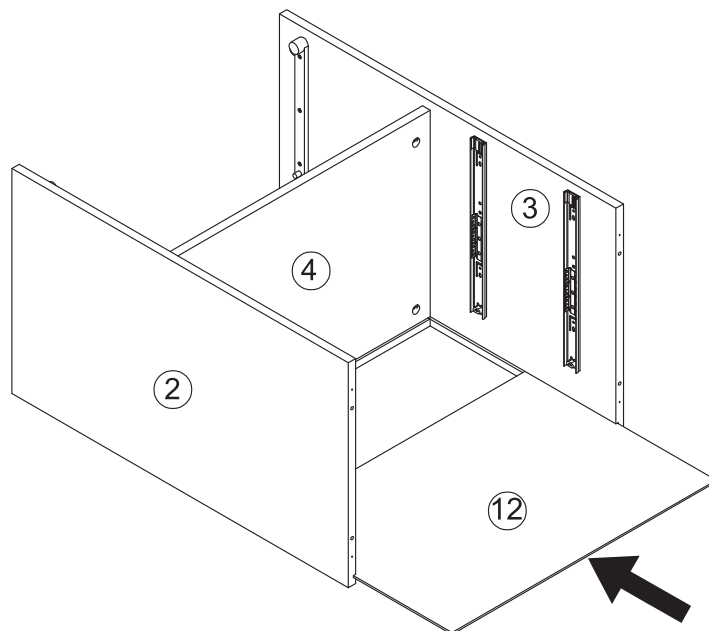

# I PRODUCT ASSEMBLY

7

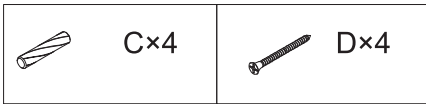
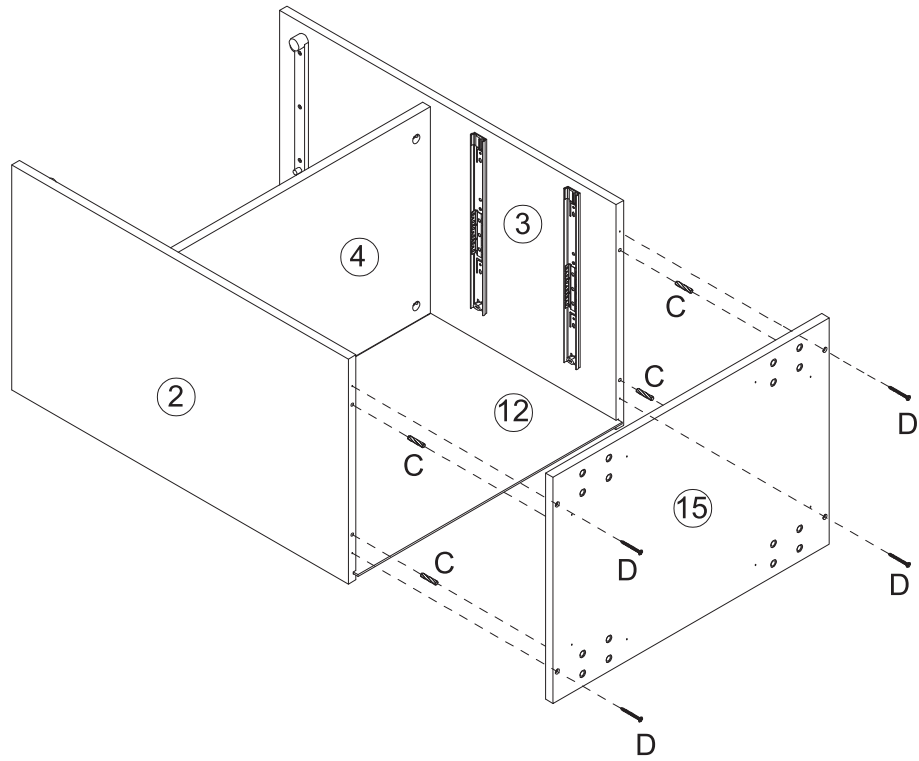

8

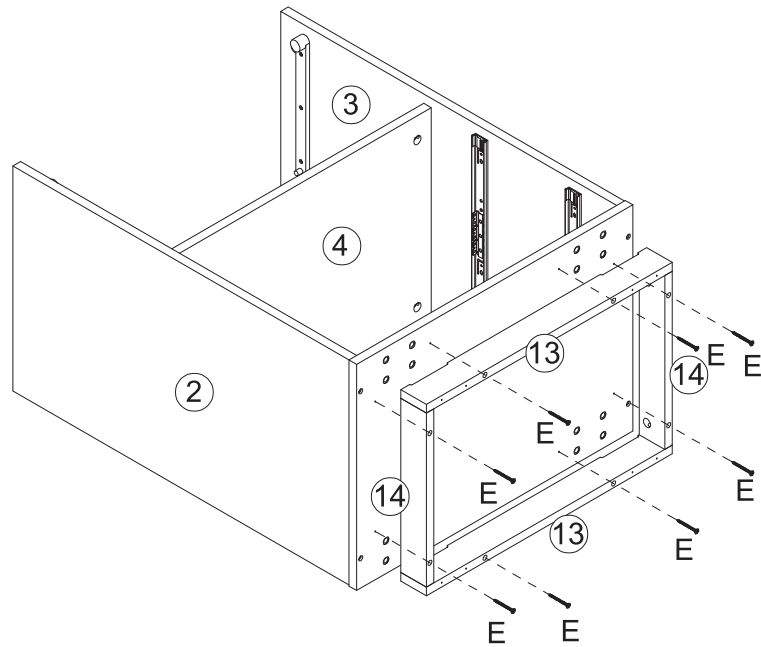

# I PRODUCT ASSEMBLY

9

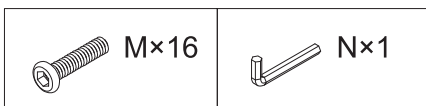
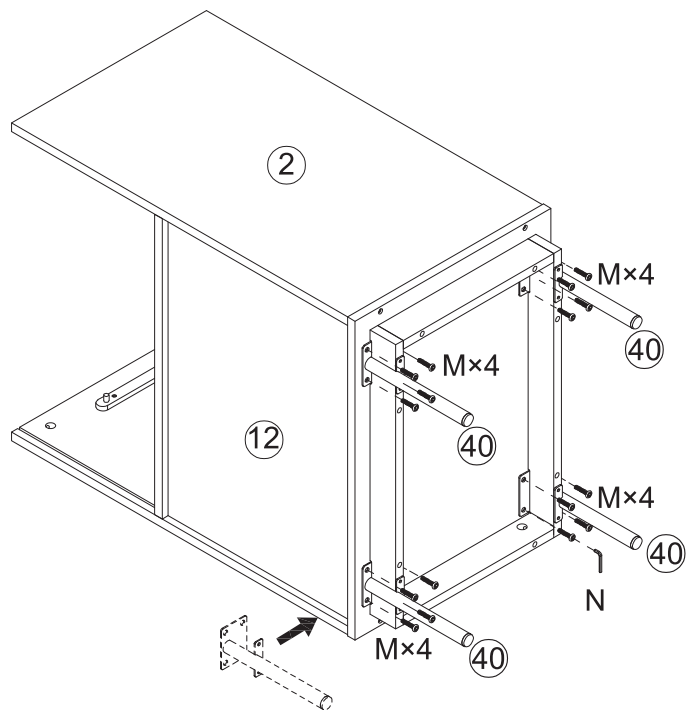

10

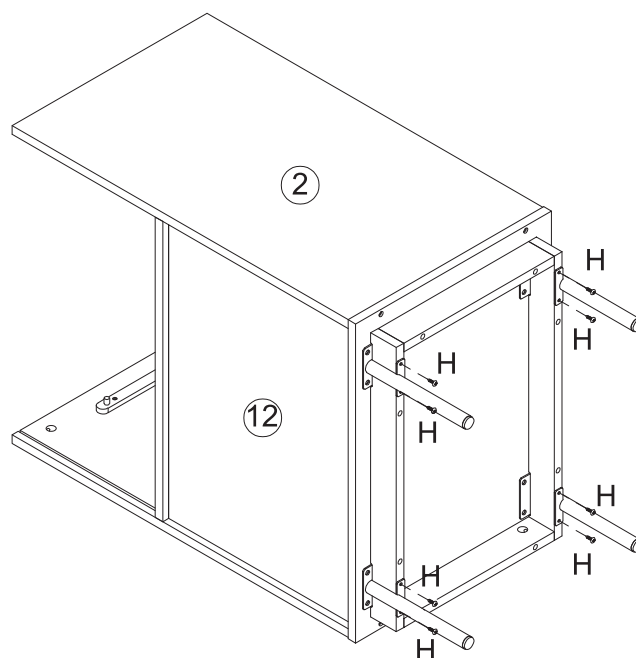

# I PRODUCT ASSEMBLY

11

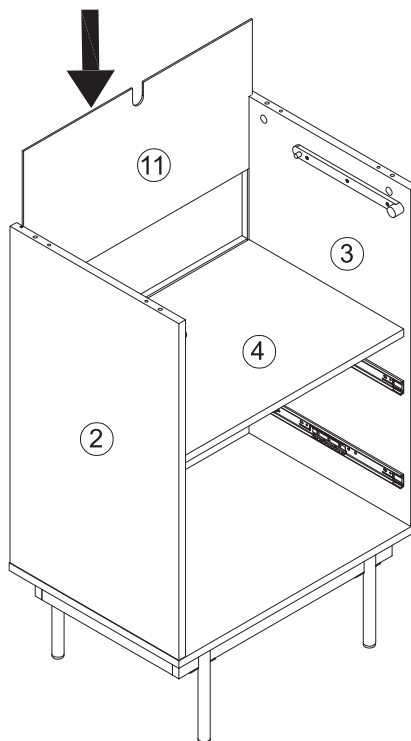

12

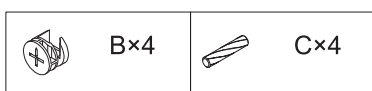
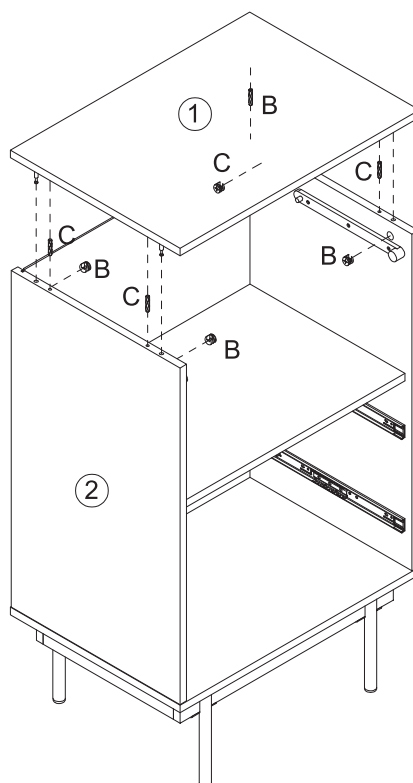

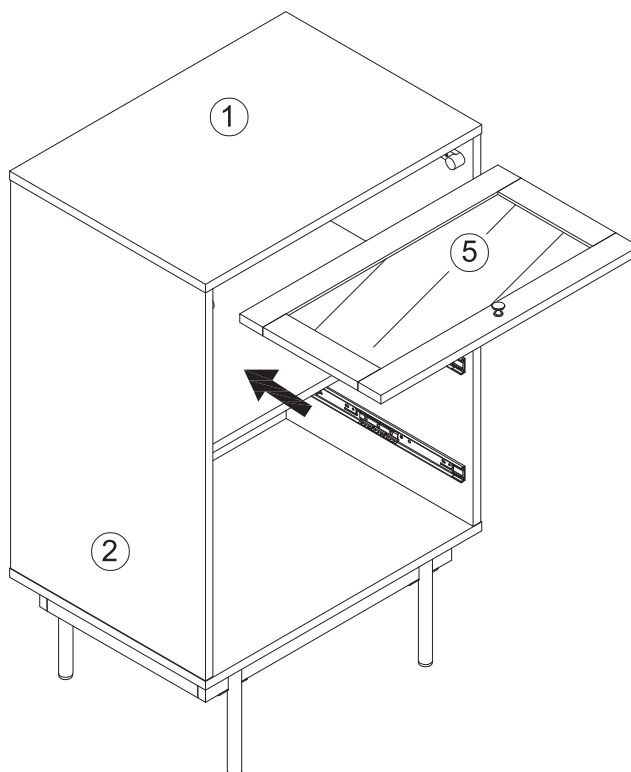

# I PRODUCT ASSEMBLY

13

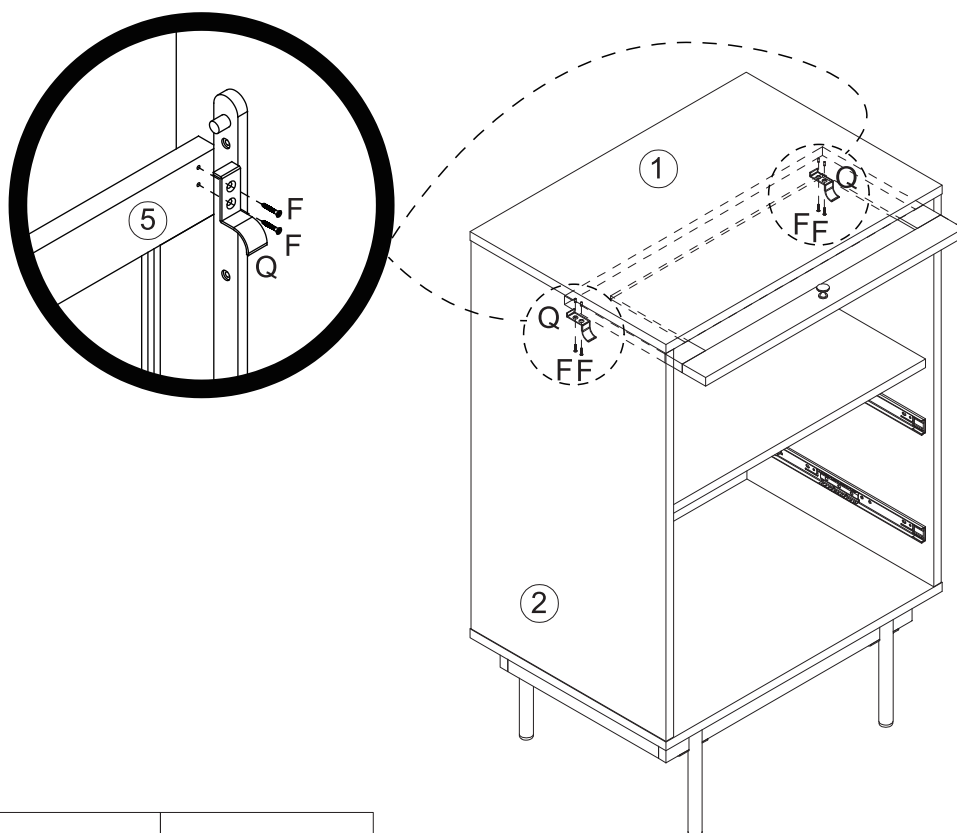

14







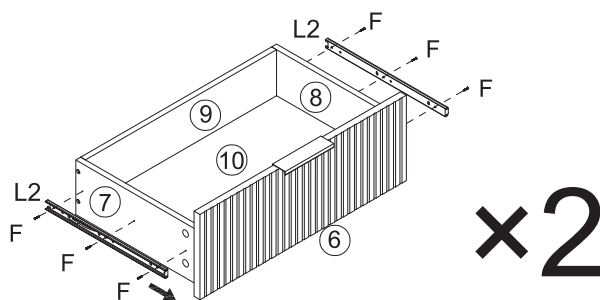
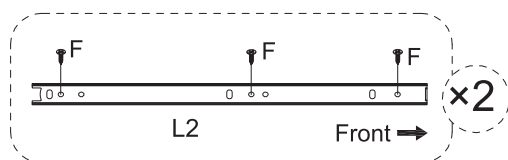
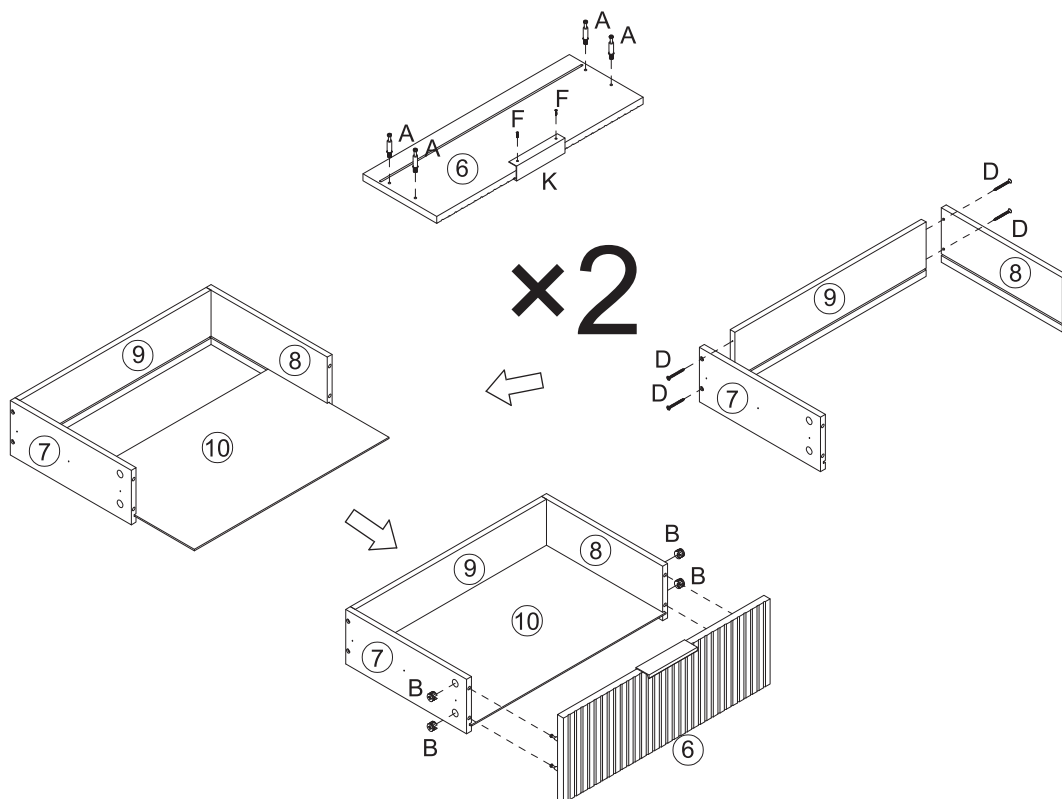

 F×4	 Q×2
-----------------------------------------------------------------------------------------	-----------------------------------------------------------------------------------------

# I PRODUCT ASSEMBLY

## 15



 A×8	 B×8	 D×8	 F×16	 L2×4	 K×2
-----------------------------------------------------------------------------------------	-----------------------------------------------------------------------------------------	-----------------------------------------------------------------------------------------	------------------------------------------------------------------------------------------	--------------------------------------------------------------------------------------------	-------------------------------------------------------------------------------------------

# I PRODUCT ASSEMBLY

## 16

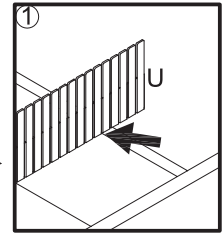
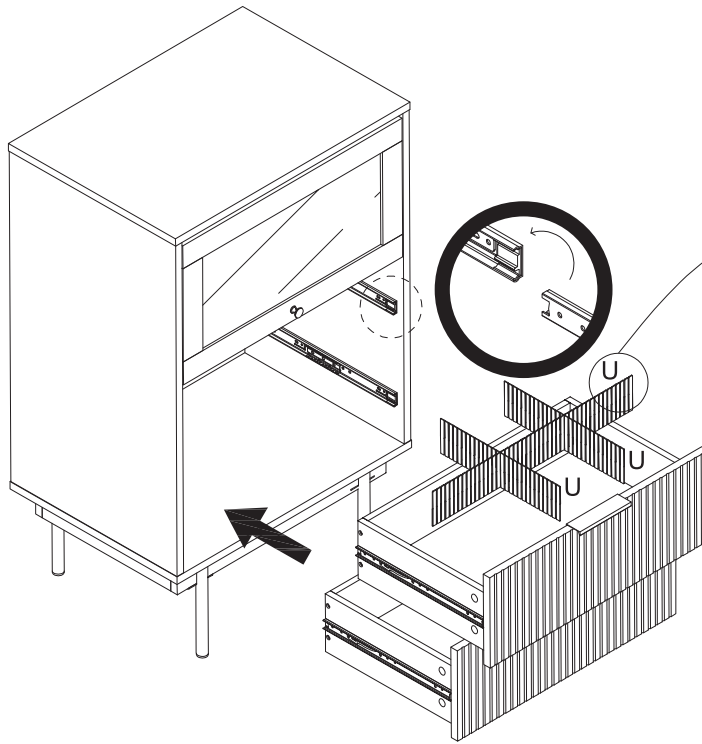

1  
Orient yourself in the desired direction, find out where it's too long

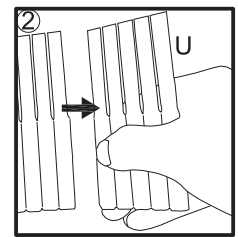

2  
Break it off



## 17

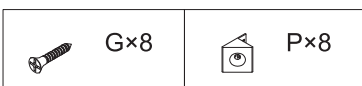
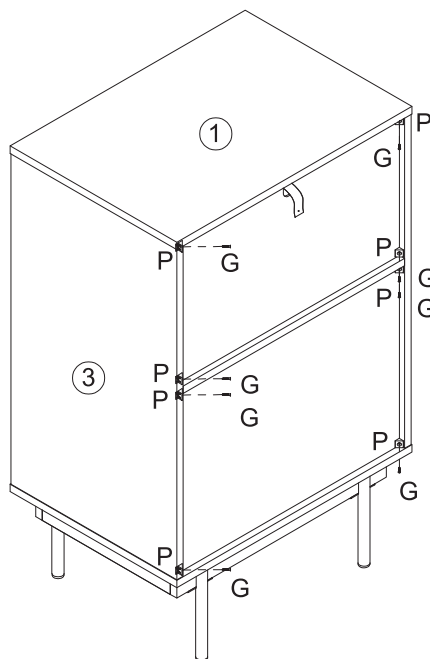

# I PRODUCT ASSEMBLY

18

