

OPEN BED FRAME

QUEEN

ASSEMBLY INSTRUCTIONS

Before assembling your bed frame, please read through these instructions carefully and familiarize yourself with the different parts.



PARTS LIST

①	FOOT RAIL	1 PC
②	LEFT LEG	1 PC
③	RIGHT LEG	1 PC
④	SIDE RAILS	2 PCS
⑤	SLAT KIT	2 SETS
⑥	SLAT SUPPORT 1	1 PC
⑦	SLAT SUPPORT 2	1 PC
⑧	SUPPORT LEGS	3 PCS

HARDWARE

①	JCB M6 X 110mm (4 3/8") - 2 pcs Spare - 1 pc	⑤	JCB M6 X 25mm(1") - 6pcs
②	Barrel nut - 2 pcs	⑥	Cap nut - 6pcs
③	JCB M8 X 15mm (5/8") - 4 pcs	⑦	Allen Screw - 3pcs
④	Wood screw(1 1/4") - 29 pcs Spare - 2 pcs	⑧	Allen wrench M6 - 1pc
		⑨	Allen wrench M4 - 1pc Spare - 1pc

NOTE: WE INCLUDE SPARE HARDWARE IN CASE DAMAGE OCCURS DURING ASSEMBLY.

Step 1

Attach the legs (2) and (3) to foot rail (1), using JCB M6 X 110mm (A) and barrel nut (B).
Tighten with the Allen wrench M4 (I).

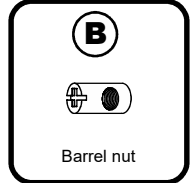
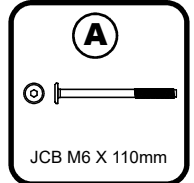
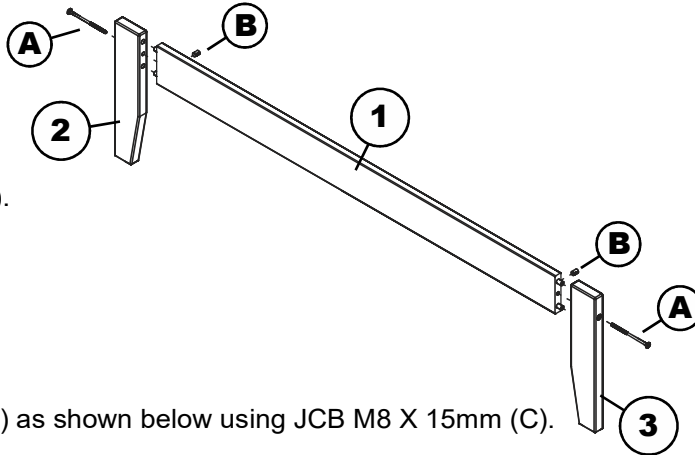

Step 2

Attach side rails (4) to the foot rail (1) as shown below using JCB M8 X 15mm (C).
Tighten with Allen wrench M6 (H).

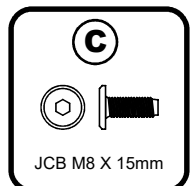
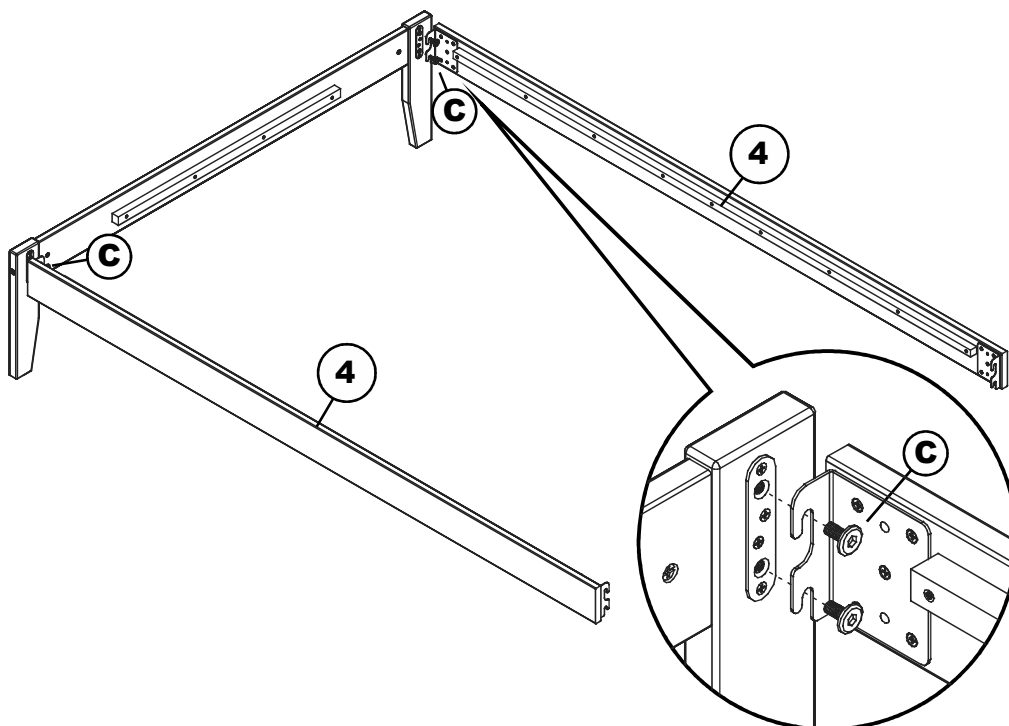

OPEN BED FRAME

QUEEN



Step 3

Attach open bed frame to the headboard as shown below using 4 JCB M8 X 15mm bolts that are supplied with your headboard. Tighten with the Allen wrench M6 (E).

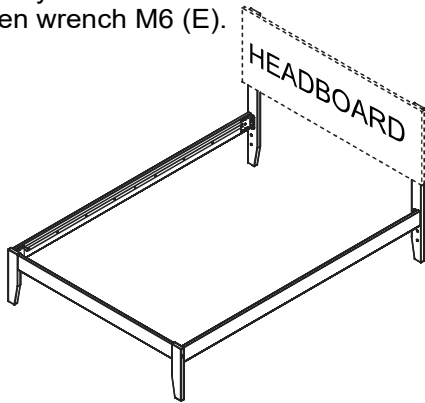
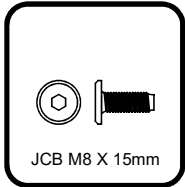

Step 4

Attach support legs (8) to slat support 1 & 2 (6)(7) as shown below. Using allen screw (G) tighten with Allen wrench M4 (I).

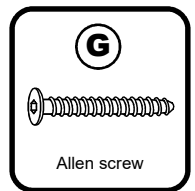
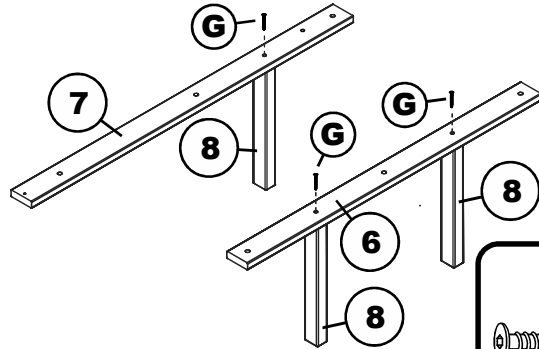

Step 5

Attach slat support 1(6) and slat support 2 (7) to the slat kit (5) as shown below using JCB M6 X 25mm (E) and cap nut (F). Tighten with Allen wrench M4 (I).

2 legs at headboard section.

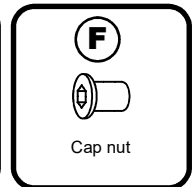
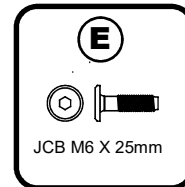
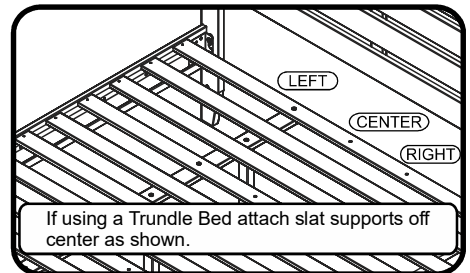
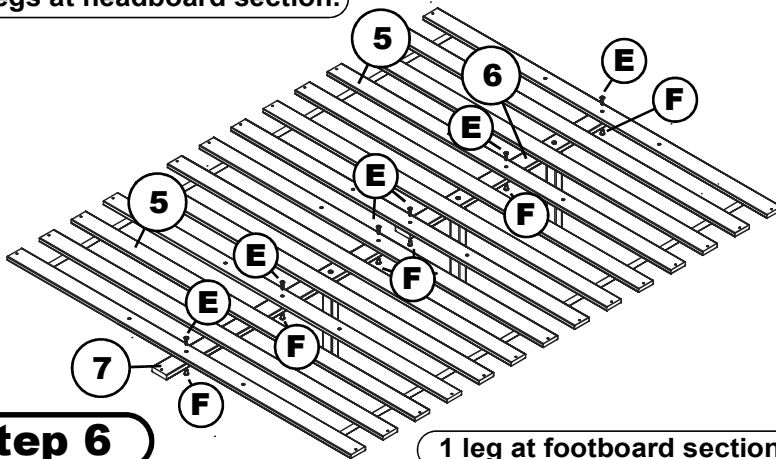

Step 6

Attach 2 slat kits (5) to the open bed frame as shown below using wood screws 1 1/4" (D). Tighten with Phillips head screw driver. (customer supplied)

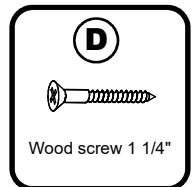
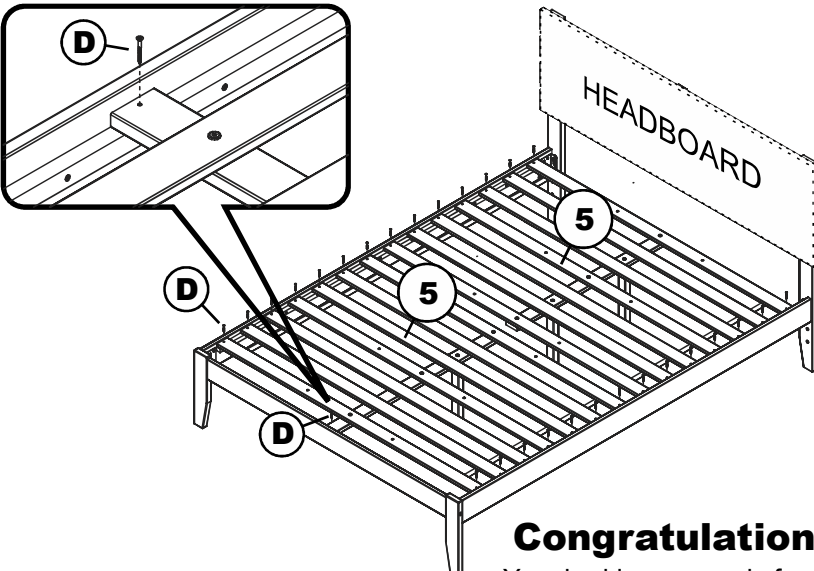

Congratulations!

Your bed is now ready for use.

We recommend that you periodically recheck that all screws are tight to ensure lasting safety.

TRUNDLE BED

TWIN XL

ASSEMBLY INSTRUCTIONS

Before assembling your Trundle bed, please read through these instructions carefully. Familiarize yourself with the different parts.

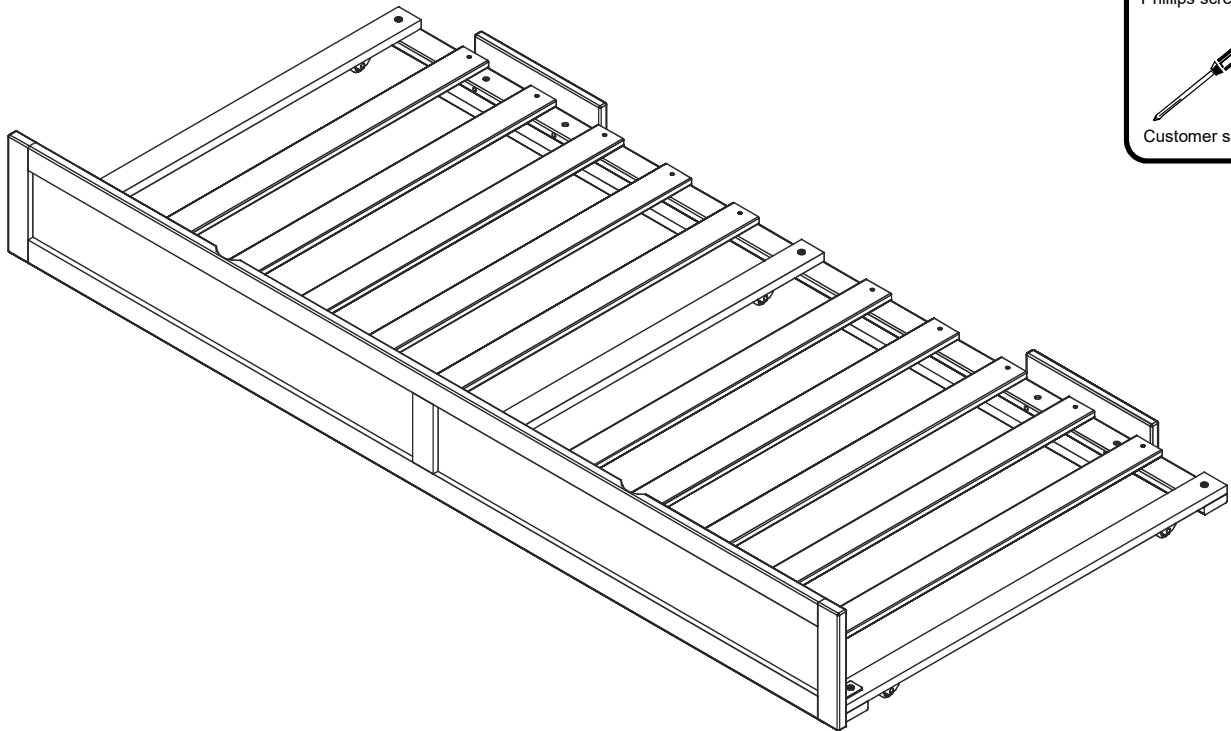

HARDWARE

NOTE: WE INCLUDE SPARE HARDWARE IN CASE DAMAGE OCCURS DURING ASSEMBLY.

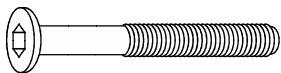

A JCB M6 X 2 3/8" (60mm) - 4 pcs
Spare - 1 pc

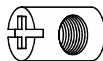

D Barrel nut - 4 pcs
For JCB M6 X 2 3/8"(60mm)

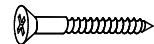

F Wood screw - 20 pcs
Spare - 2 pcs

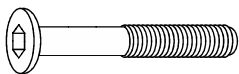

B JCB M6 X 1 5/8" (40mm) - 9 pcs
Spare - 1 pc

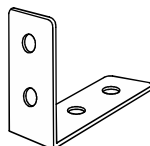

E L Bracket - 3 pcs



G Allen wrench - 1 pc
Spare - 1 pc

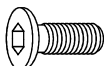

C JCB M6 X 5/8" (15mm) - 6 pcs
Spare - 1 pc
Fix L bracket to front panel

TRUNDLE BED

TWIN XL PARTS LIST

01	HARDWARE	1 BOX	05	LEFT, RIGHT, MID RAIL	3 PCS
02	FRONT PANEL	1 PC	06	REAR BLOCK	2 PCS
03	FRONT RAIL	1 PC	07	SLAT KIT WITH WEBBING	2 SETS
04	BACK RAIL	1 PC			

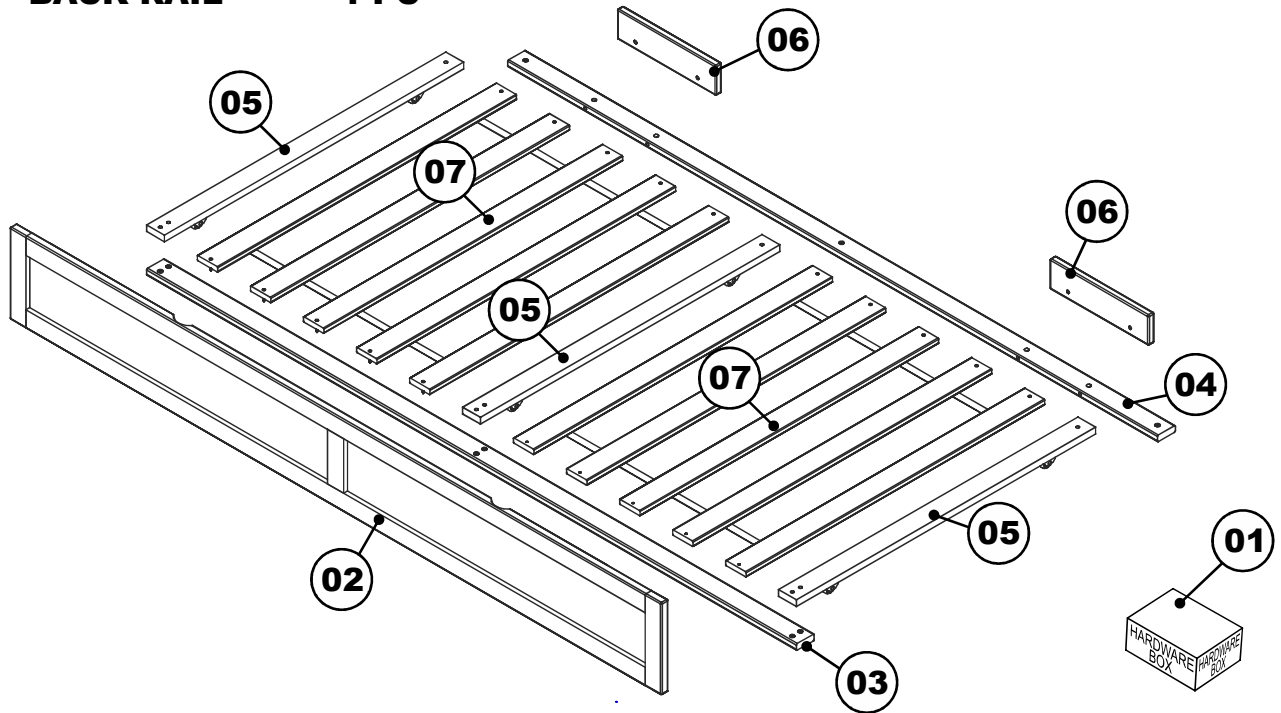

Step 1

Attach the left, right and mid rails (05) to the front rail (03) using L bracket (E) and JCB M6 X 1 5/8" (B). Attach left, right and mid rails (05) to the back rail (4) using JCB M6 X 1 5/8" (B). Tighten with the Allen wrench (G).

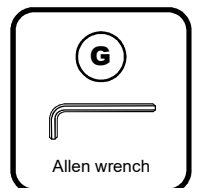
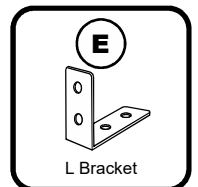
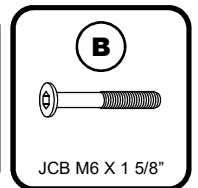
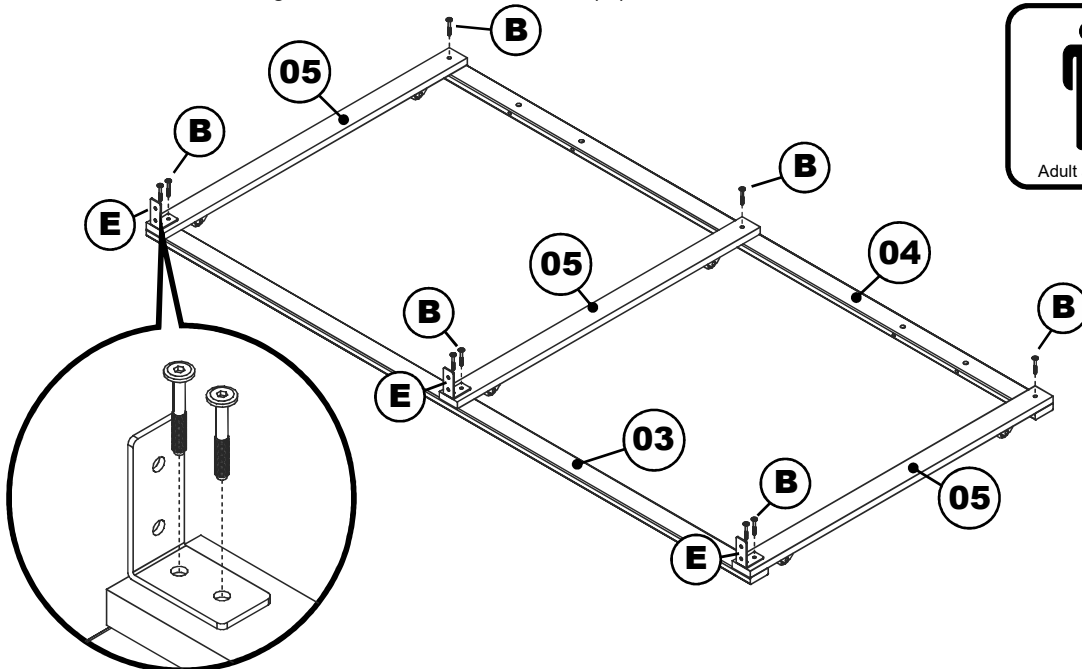

TRUNDLE BED

TWIN XL

Step 2

Attach the front panel (02) to the front rail (03) as shown, using JCB M6 X 5/8" (C). Tighten with the Allen wrench (G).

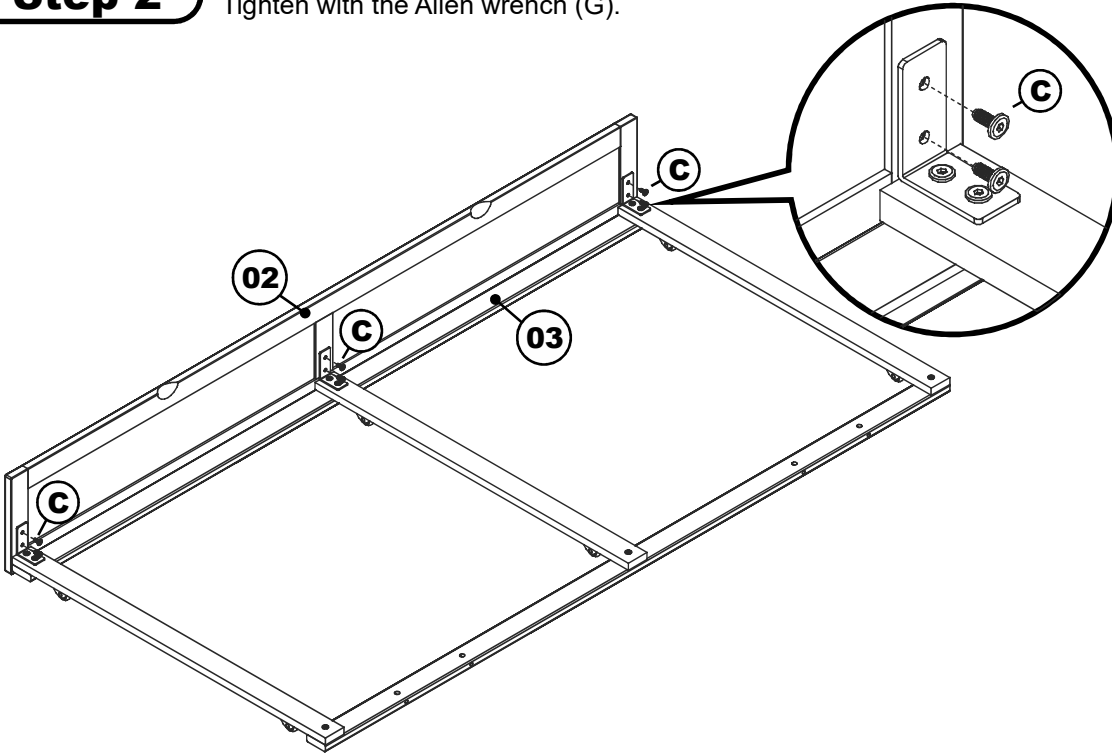

C



G



Step 3

Lay the slat kits (07) webbing side down onto the rail assembly as shown. Attach using wood screw (F) and tighten with the Phillips head screw driver. (customer supplied)

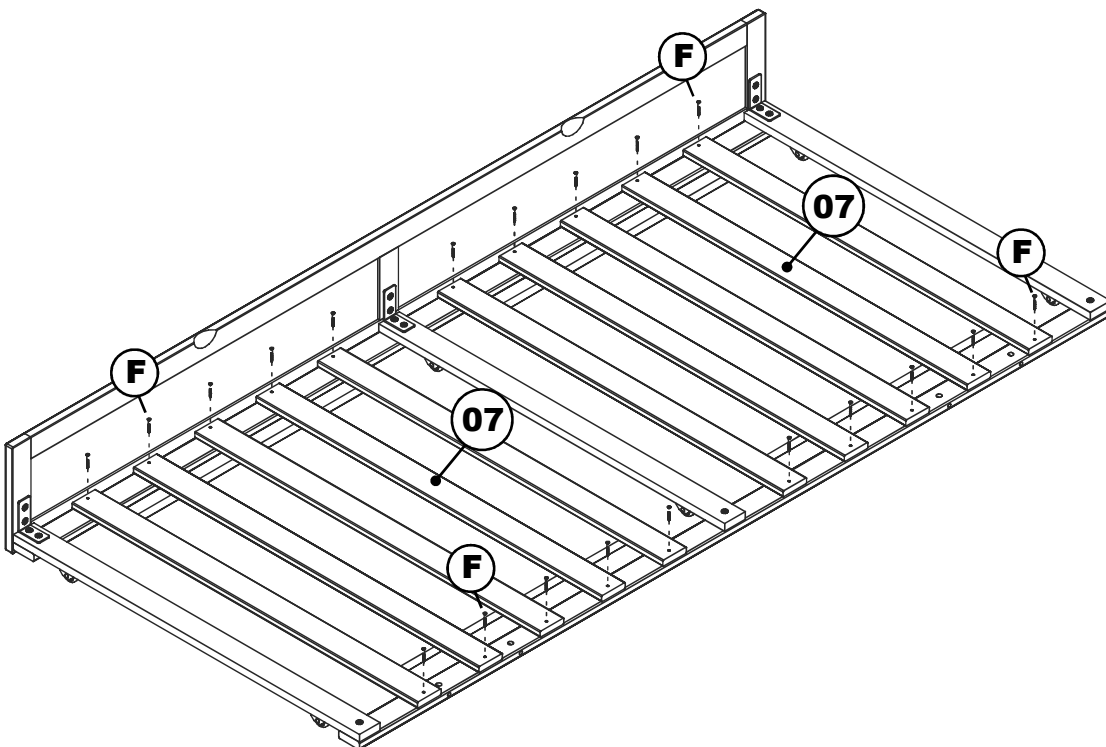

F

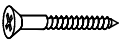

Phillips screwdriver



TRUNDLE BED

TWIN XL

Step 4

Attach the rear blocks (06) to the back rail (04) as shown using JCB M6 X 2 3/8" (A) barrel nut (D) Tighten with the Allen wrench (G)

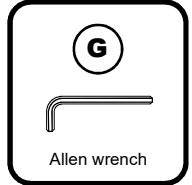
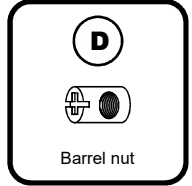
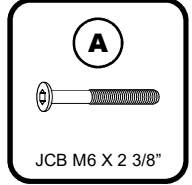
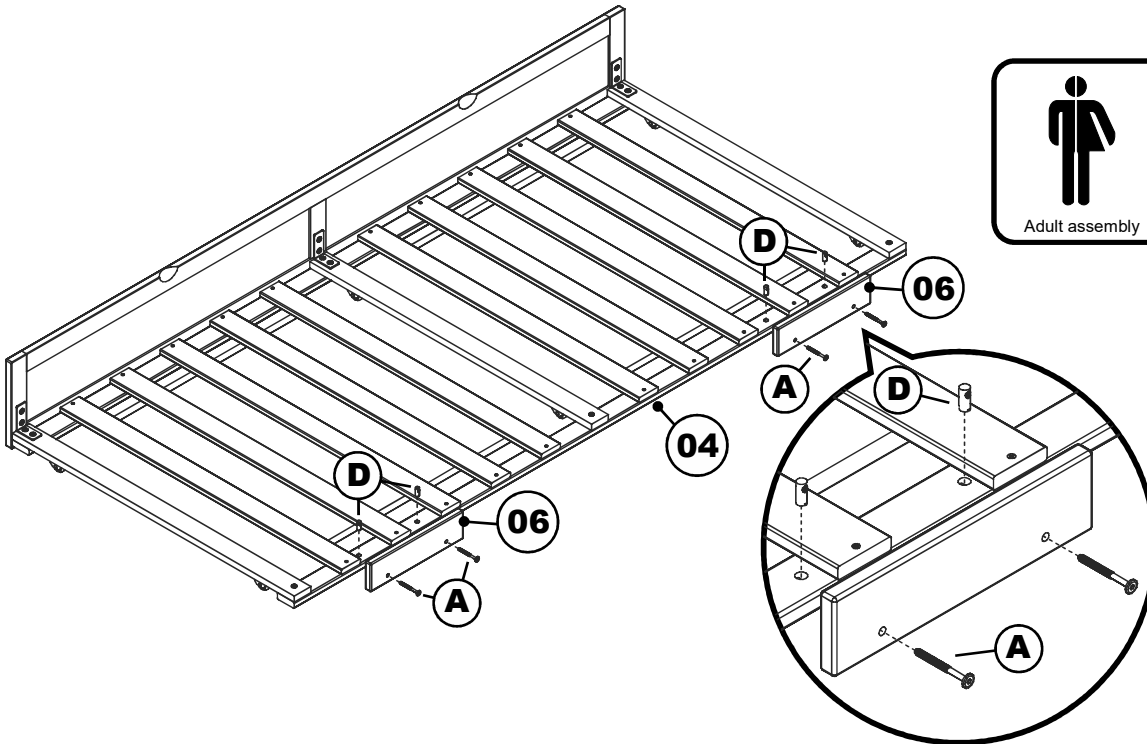

Step 5

Lastly, Insert Trundle bed to the bed as shown below.

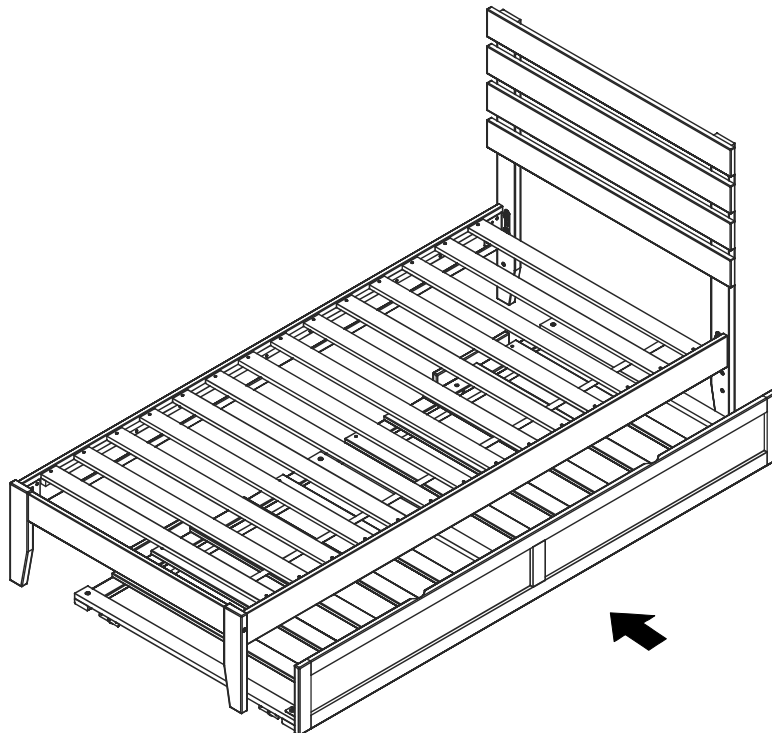

Congratulations!

Your Trundle bed is now ready for use.
We recommend that you periodically check that all screws are tight and all parts are secure to ensure lasting safety.