

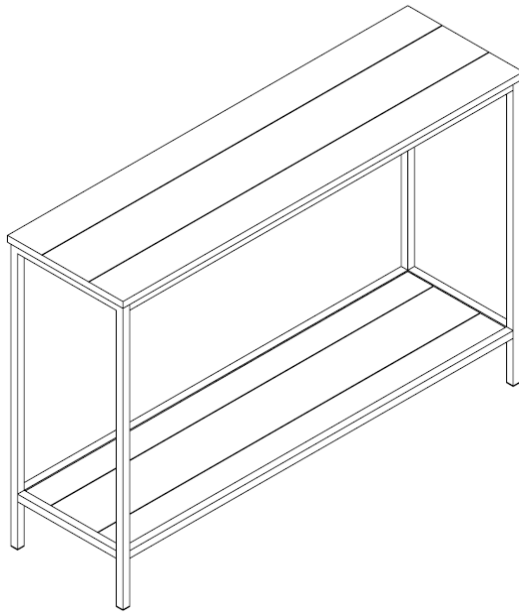

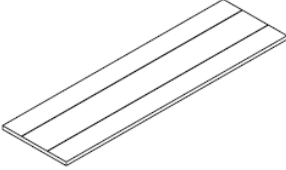

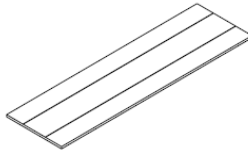

Console Table



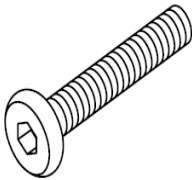

PART LIST

A	B	C	D	E
				
<p>Wood Top 1 PC</p>	<p>Wood Shelf 1 PC</p>	<p>Side Frame 2 PCS</p>	<p>Bottom Rail 2 PCS</p>	<p>Top Rail 2 PCS</p>

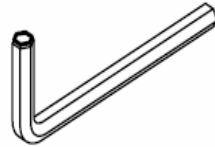
HARDWARE LIST

#1	#2	#3
		
<p>$1/4" \times 1-1/8" L$ Long Bolt 8 PCS</p>	<p>$1/4" \times 1/2" L$ Short Bolt 22 PCS</p>	<p>Allen Key 1 PC</p>

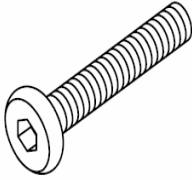
EXTRA HARDWARE LIST

#1	#2
	
<p>$1/4" \times 1-1/8" L$ Long Bolt 2 PCS</p>	<p>$1/4" \times 1/2" L$ Short Bolt 3 PCS</p>

Step 1. Attach top rails (part #E) to wood top (part #A) by using long bolts (part #1) and allen key (part #3).

NOTE: Please do not fully tighten bolts until unit is fully assembled.

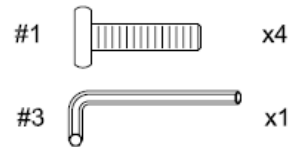
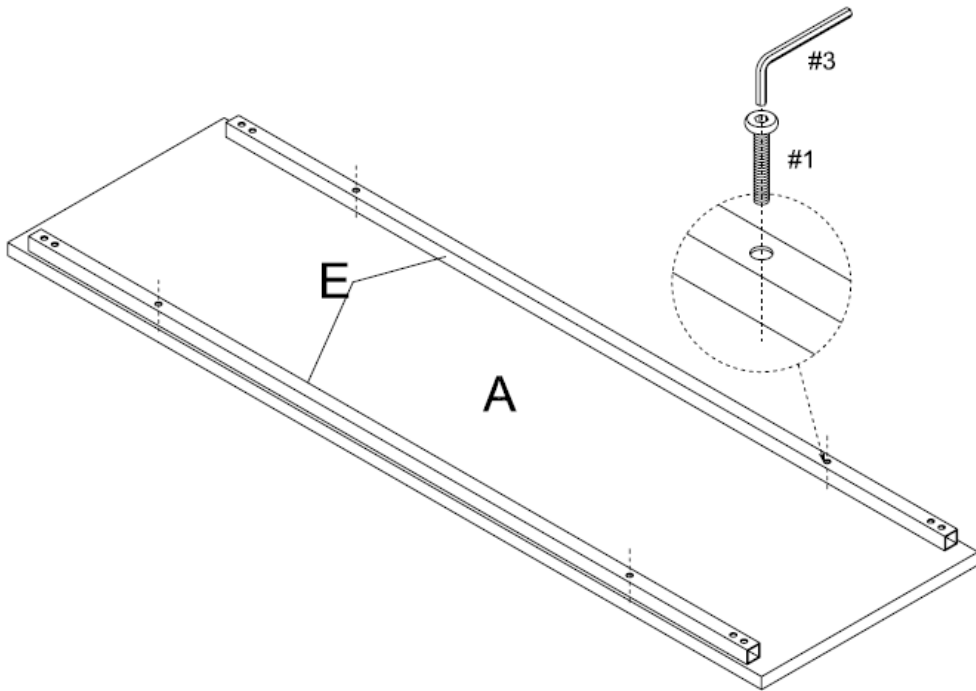

Step 2. Attach bottom rails (part #D) to wood shelf (part #B) by using short bolts (part #2) and allen key (part #3).

NOTE: Please do not fully tighten bolts until unit is fully assembled.

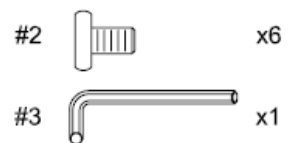
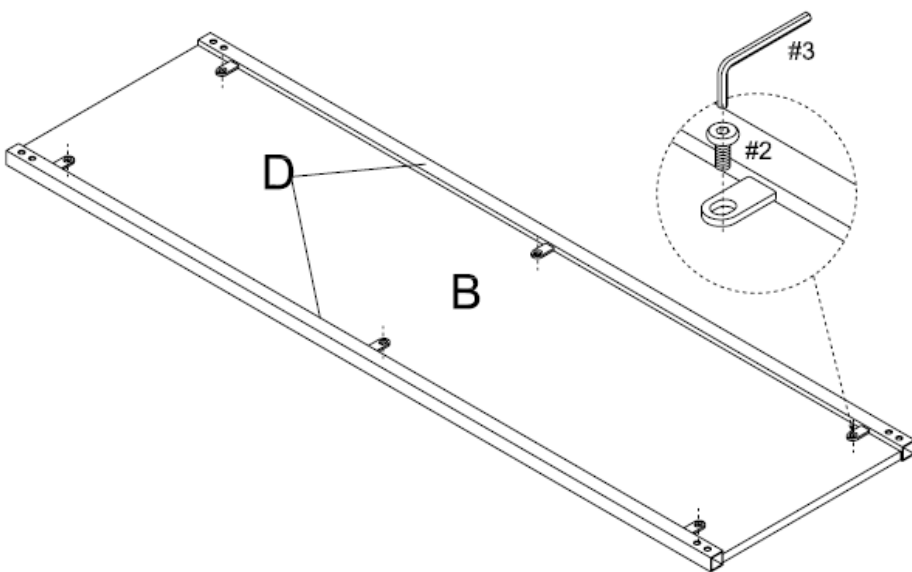



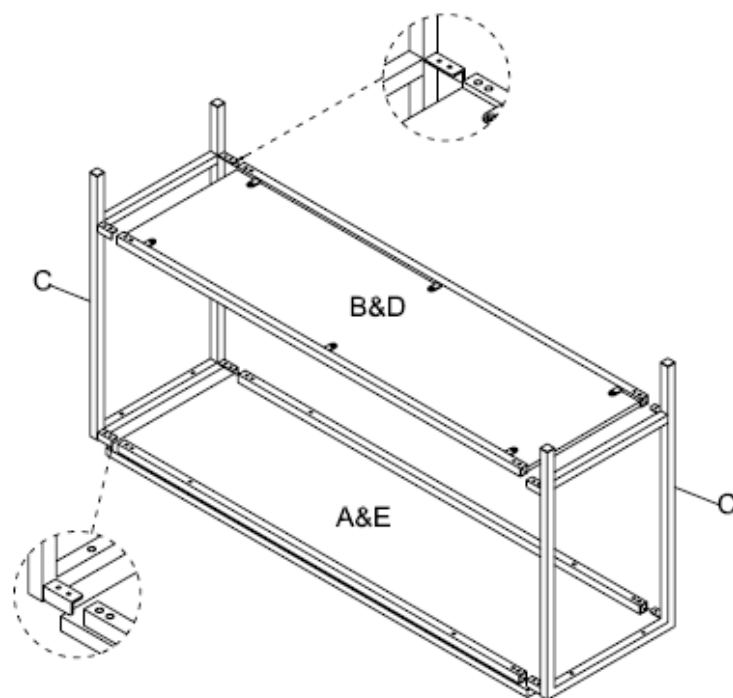

Step 3. Slide side frames (part #C) into assembled parts (parts #A&E) and assembled parts (parts #B&D) by inserting the L-shaped brackets into the ends of the bottom rails (part #D) and the top rails (part #E) on both sides.

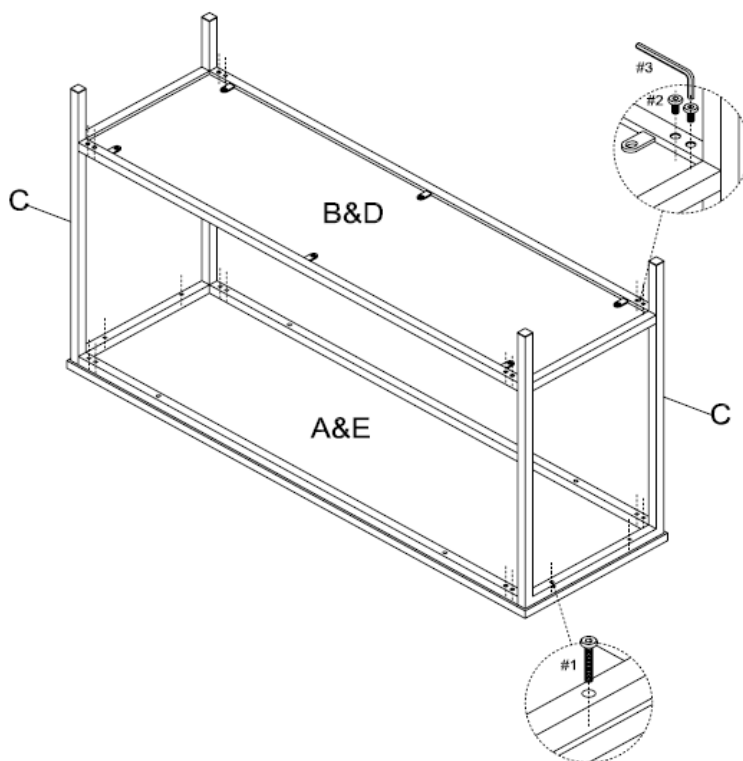

Step 4. Attach side frames (part #C) to assembled parts (parts #A&E) and assembled parts (parts #B&D) by using short bolts (part #2) and allen key (part #3) where the L-shaped brackets are inside the ends of the bottom rails (part #D) and the top rails (part #E). Secure assembled parts (parts #A&E) to side frames (part #C) with long bolts (part #1) and allen key (part #3).

NOTE: Please fully tighten all bolts at this time.



- | | | |
|----|---|-----|
| #1 |  | x4 |
| #2 |  | x16 |
| #3 |  | x1 |

Step 5. Carefully turn the table upright

