

ASSEMBLY INSTRUCTIONS

INSTRUCTIONS DE MONTAGE

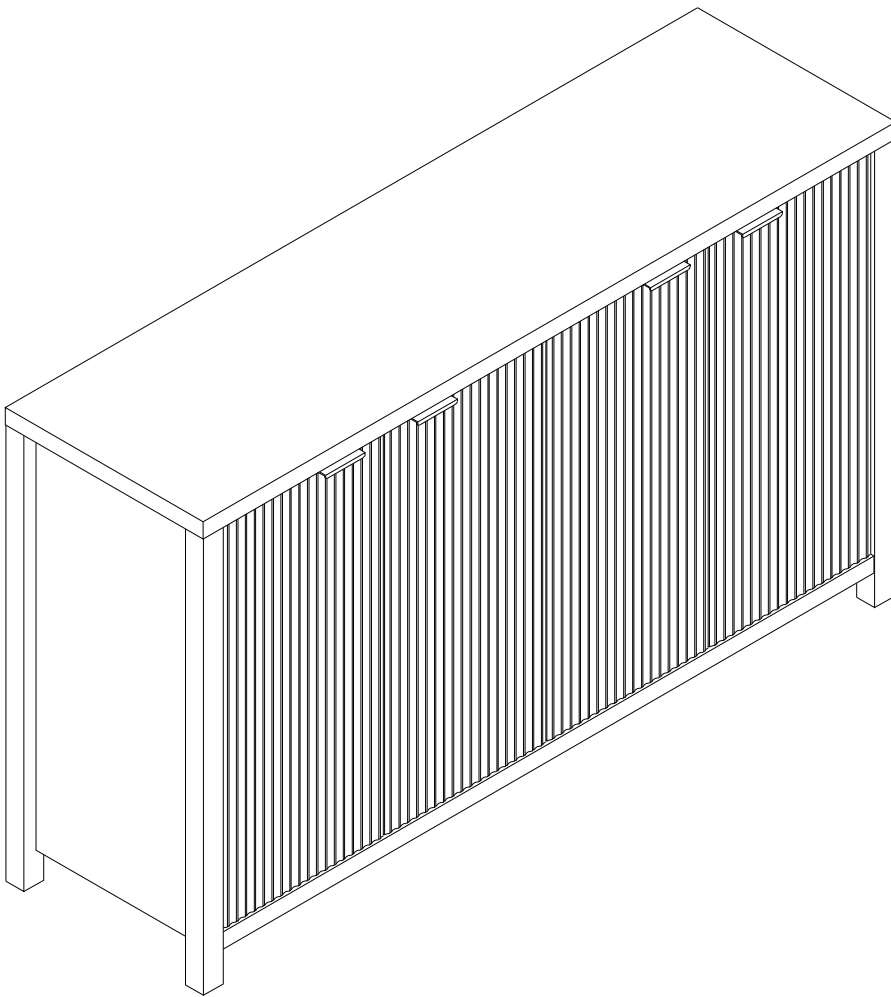

Detail View/ Vue détaillée

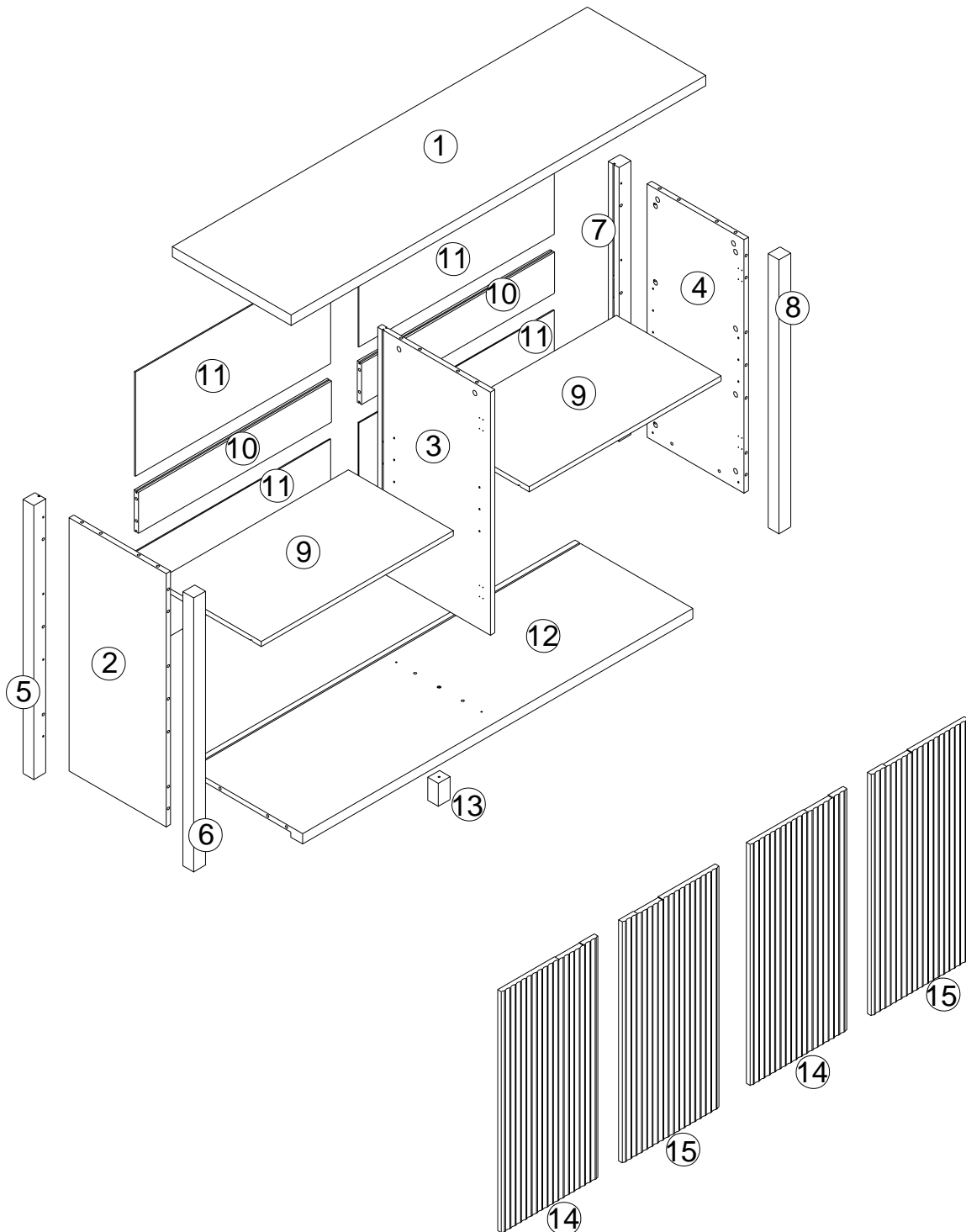

Part List / Liste des pieces

BOX1: N853P285596

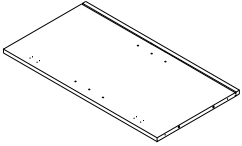
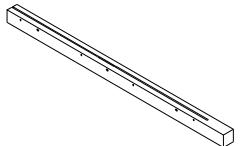
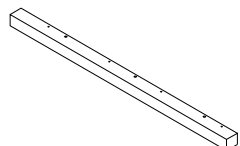
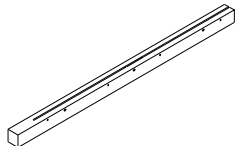
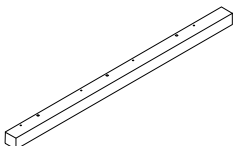
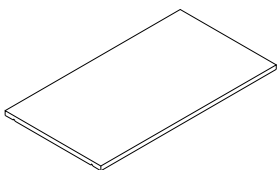
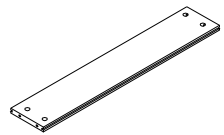
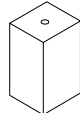
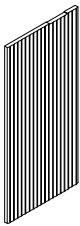
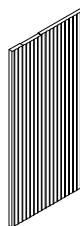
 <p>3 x1</p>	 <p>5 x1</p>	 <p>6 x1</p>	 <p>7 x1</p>
<p>Middle Partition La séparation intermédiaire</p>	<p>Left rear leg Pied avant gauche</p>	<p>Left front leg Pied avant gauche</p>	<p>Right rear leg Pied arrière droit</p>
 <p>8 x1</p>	 <p>9 x2</p>	 <p>10 x2</p>	 <p>13 x1</p>
<p>Right front leg Pied avant droit</p>	<p>Shelf Produits laminés</p>	<p>Back crossbar Tirant dans le dos</p>	<p>Middle leg Pied de support intermédiaire</p>
 <p>14 x2</p>	 <p>15 x2</p>	<p>Hardware List Liste du matériel</p>	
<p>Left Door Panneau de porte gauche</p>	<p>Right Door Panneau de porte droit</p>		





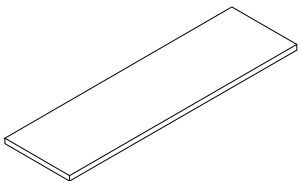
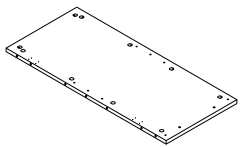
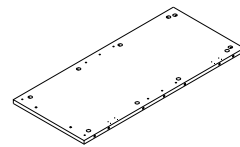
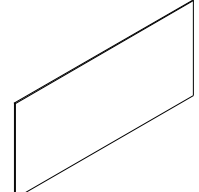
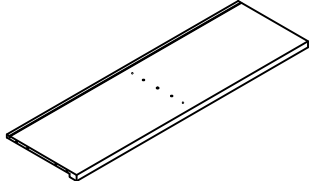







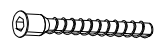

Part List / Liste des pieces

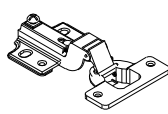
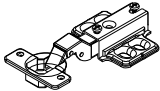
BOX1: N853P285597

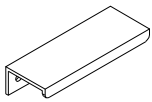
 <p>1 x1</p>	 <p>2 x1</p>	 <p>4 x1</p>	 <p>11 x4</p>
<p>Top Panel Panneau supérieur</p>	<p>Left panel Panneau latéral gauche</p>	<p>Right panel Panneau latéral droit</p>	<p>Back panel Dossier</p>
 <p>12 x1</p>			
<p>Bottom Panel Panneau inférieur</p>			

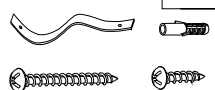
Hardware List / Liste du

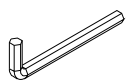
N853P285596

<p>A x34 +1 Φ6x35mm</p> 	<p>B x34 +1 Φ15x9mm</p> 	<p>C x24 +1 Φ8x30mm</p> 	<p>D x48 +1 Φ3.5x14mm</p> 
<p>Cam Bolt Boulon à came</p>	<p>Cam Nut Écrou à came</p>	<p>Wood dowel Cheville en bois</p>	<p>Screw Vis à bois</p>
<p>E x3 Φ7x45mm</p> 	<p>F x8 +1</p> 	<p>G x 4</p> 	<p>H x 4</p> 
<p>Screw Vis à bois</p>	<p>Shelf Support Support d'étagère</p>	<p>Hinge Charnière</p>	<p>Hinge Charnière</p>
<p>I x8 +1 Φ3x12mm</p> 	<p>J x 4</p> 	<p>K x 2</p> 	<p>L x4 +1 Φ3x12mm</p> 
<p>Screw Vis à bois</p>	<p>Handle Poignée</p>	<p>Door Stopper Butoir de porte</p>	<p>Screw Vis à bois</p>
<p>M x 2 Φ4x30mm Φ4x14mm</p> 	<p>N x 1</p> 	<p>O x16 +1 Φ3x14mm</p> 	<p>P x 1</p> 
<p>Anti-lip device Dispositif anti-renversement</p>	<p>Adjustable leg Pieds de réglage</p>	<p>Single Plastic Cap Bouchon en plastique simple</p>	<p>Allen wrench Clé Allen</p>
<p>Q x20 +1</p> 			
<p>Paper cover Couvercle en papier</p>			

ASSEMBLY TOOLS REQUIRED (NOT INCLUDED)
OUTILS D'ASSEMBLAGE REQUIS (NON INCLUS)

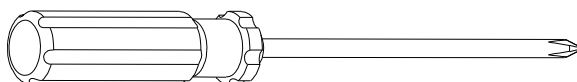

PLEASE BE CAREFUL DO NOT DAMAGE THE HOLE POSITION WHEN YOU USE
POWER TOOLS !
FAITES ATTENTION À NE PAS ENDOMMAGER LA POSITION DE MAINTIEN LORSQUE
VOUS UTILISEZ DES OUTILS ÉLECTRIQUES !

STEP 1 / ETAPE 1:

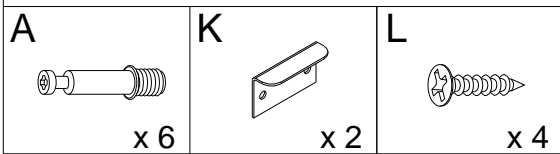
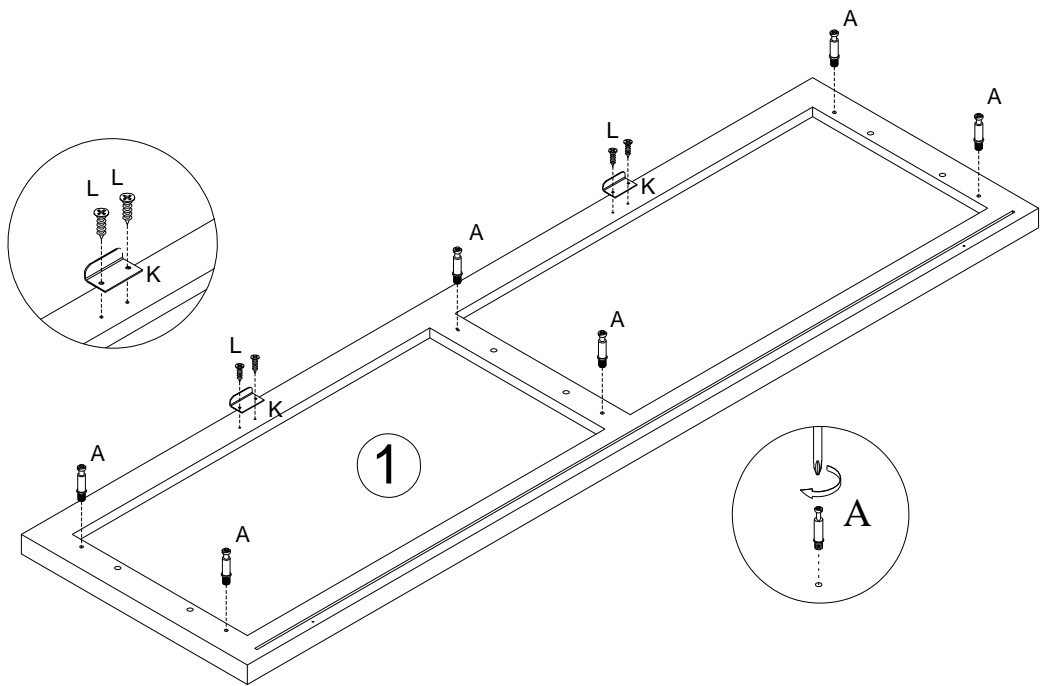

STEP 2 / ETAPE 2:

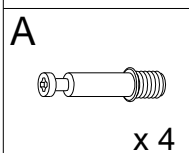
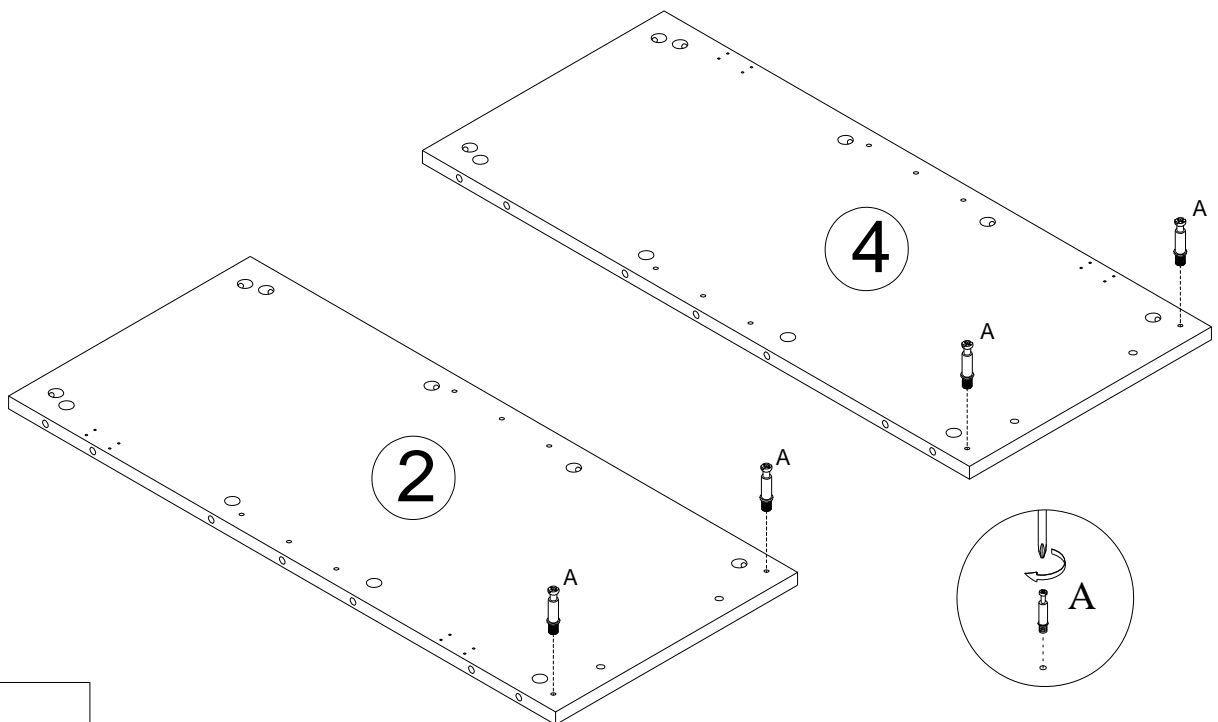

STEP 3 / ÉTAPE 3:

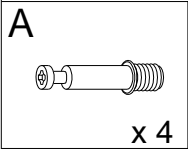
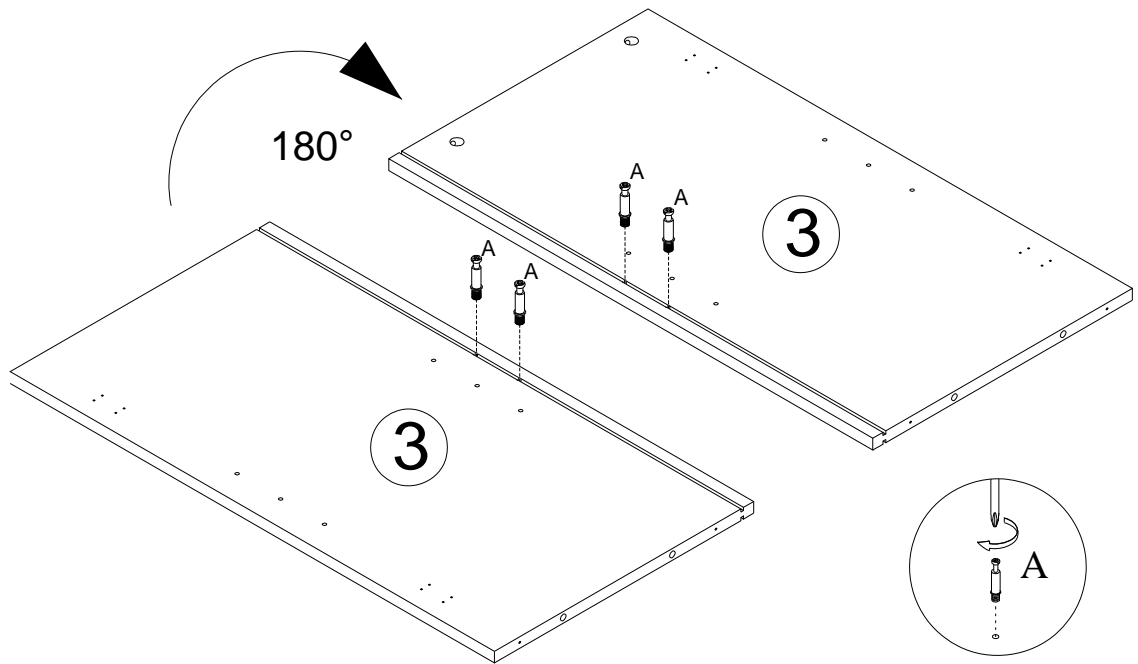

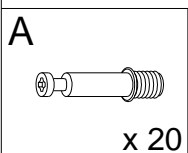
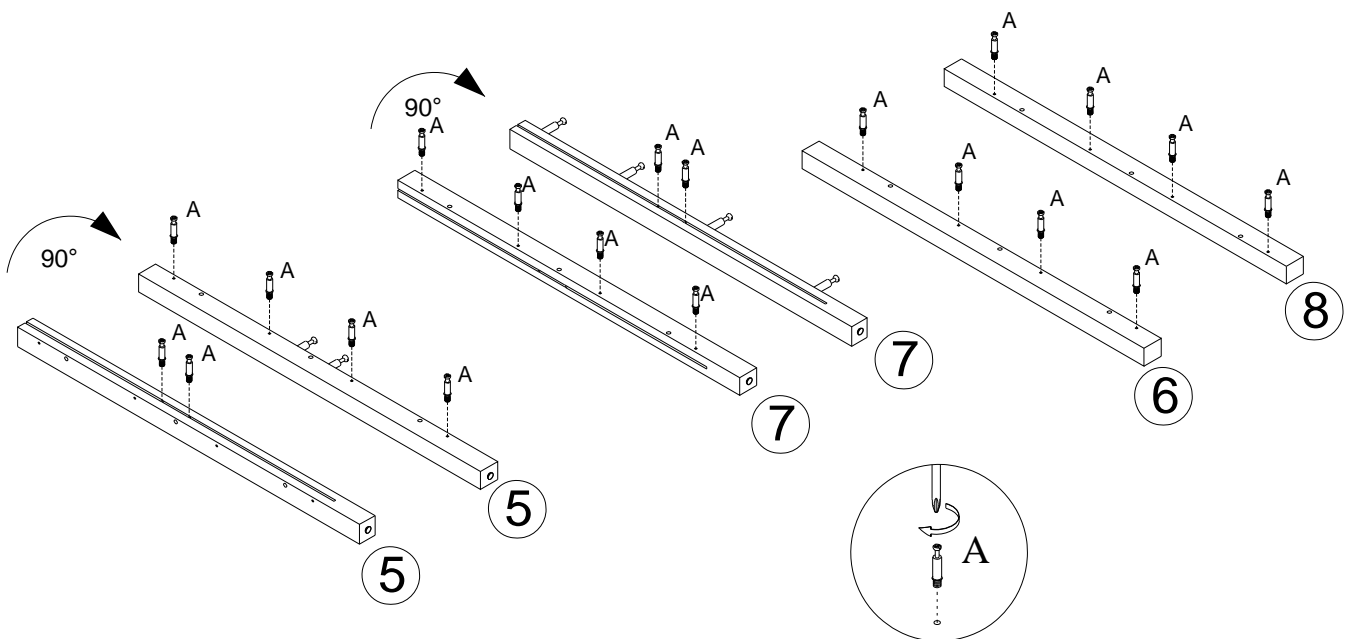

STEP 4 / ÉTAPE 4:



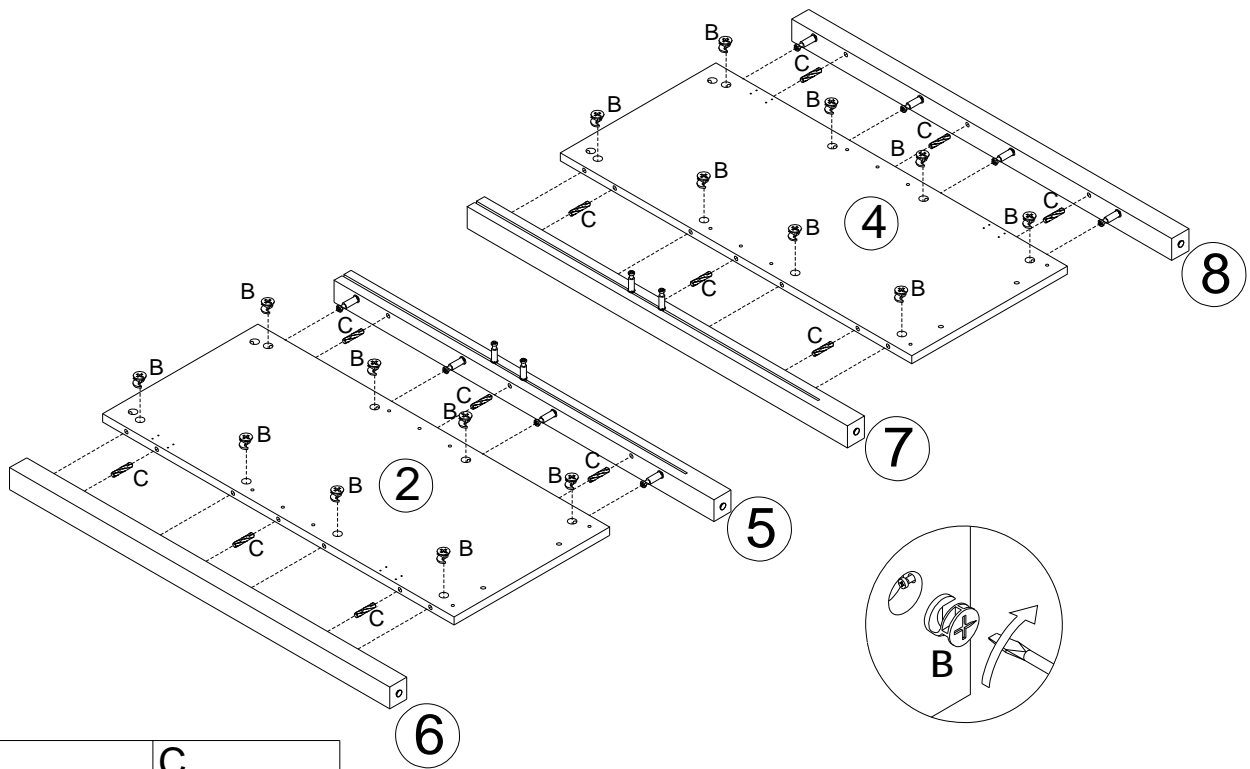

STEP 4 / ÉTAPE 4:

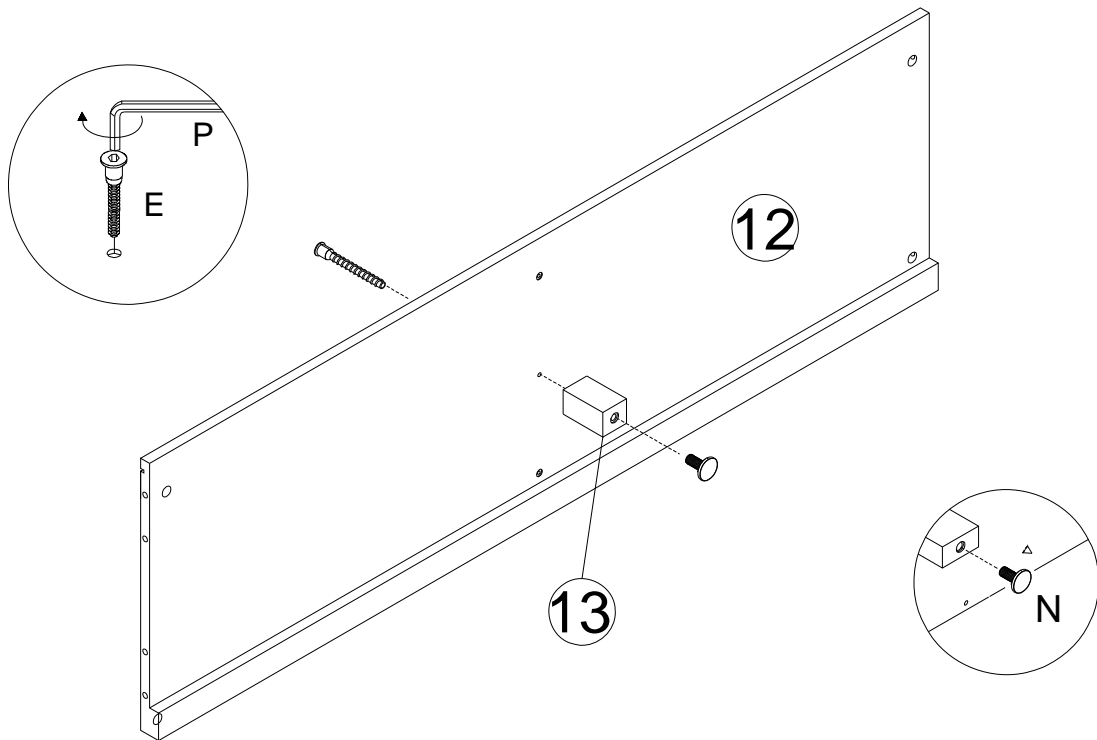

<p>B</p>  <p>x 16</p>	<p>C</p>  <p>x 12</p>
---	---

STEP 6 / ÉTAPE 6:

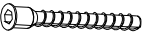

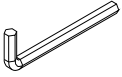
<p>E</p>  <p>x 1</p>	<p>N</p>  <p>x 1</p>	<p>P</p>  <p>x 1</p>
--	--	--

STEP 7 / ÉTAPE 7:

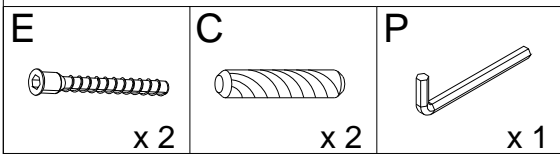
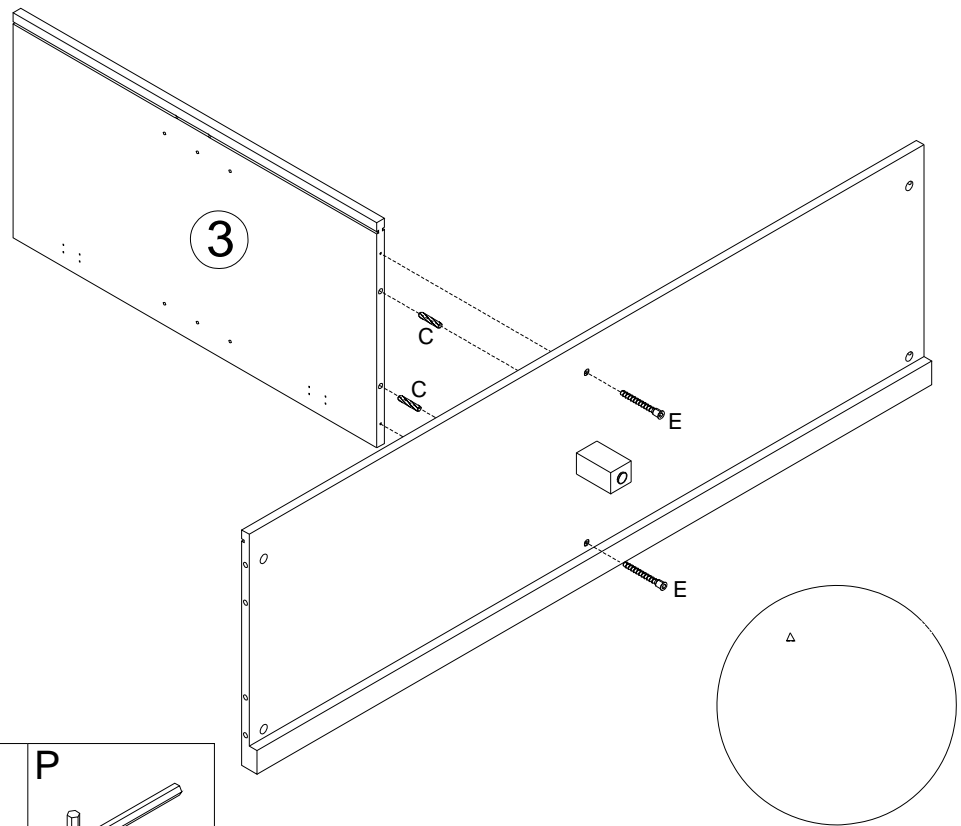

STEP 8 / ÉTAPE 8:

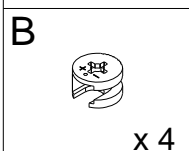
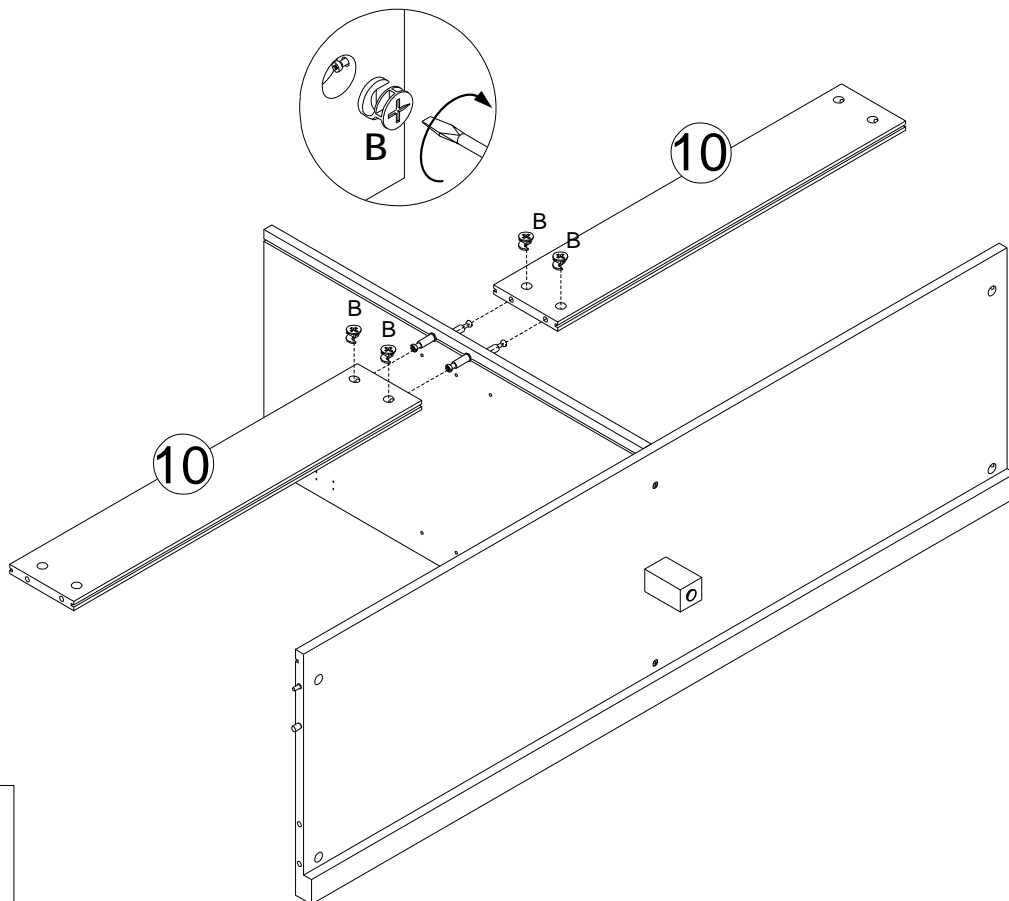

STEP 9 / ÉTAPE 9:

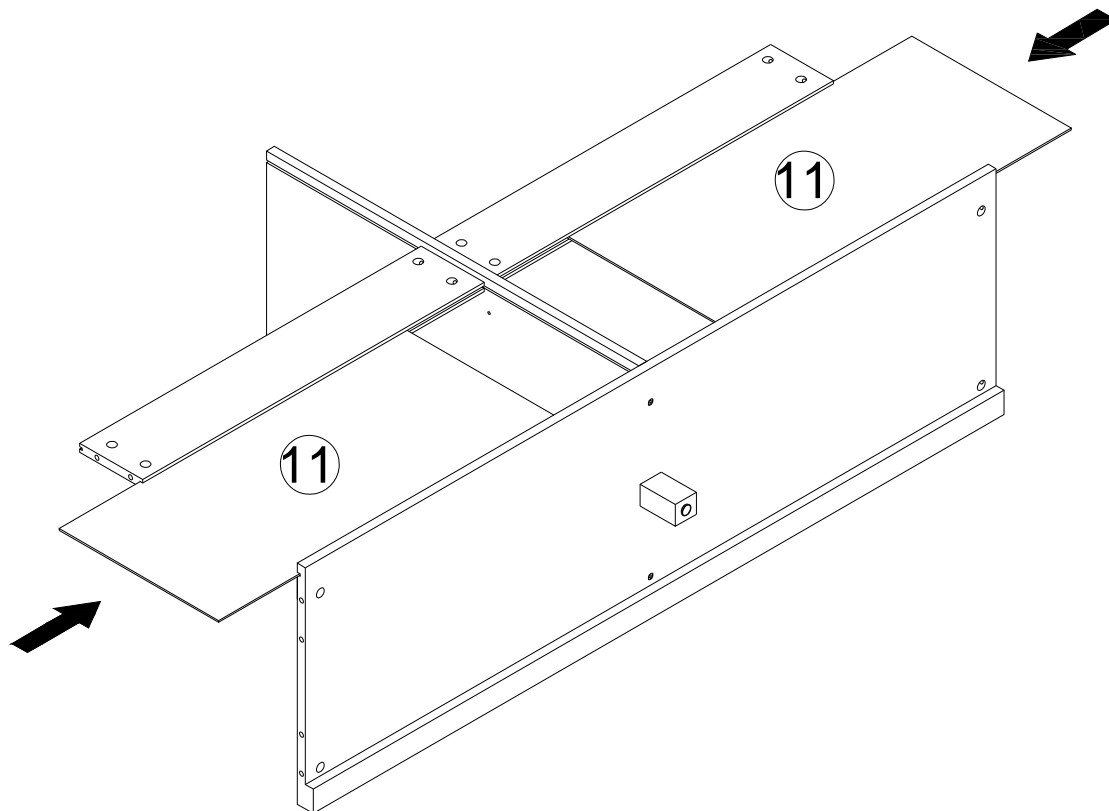

STEP 10 / ÉTAPE 10:

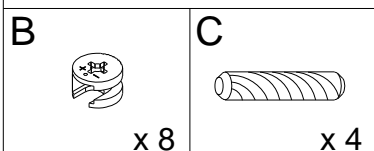
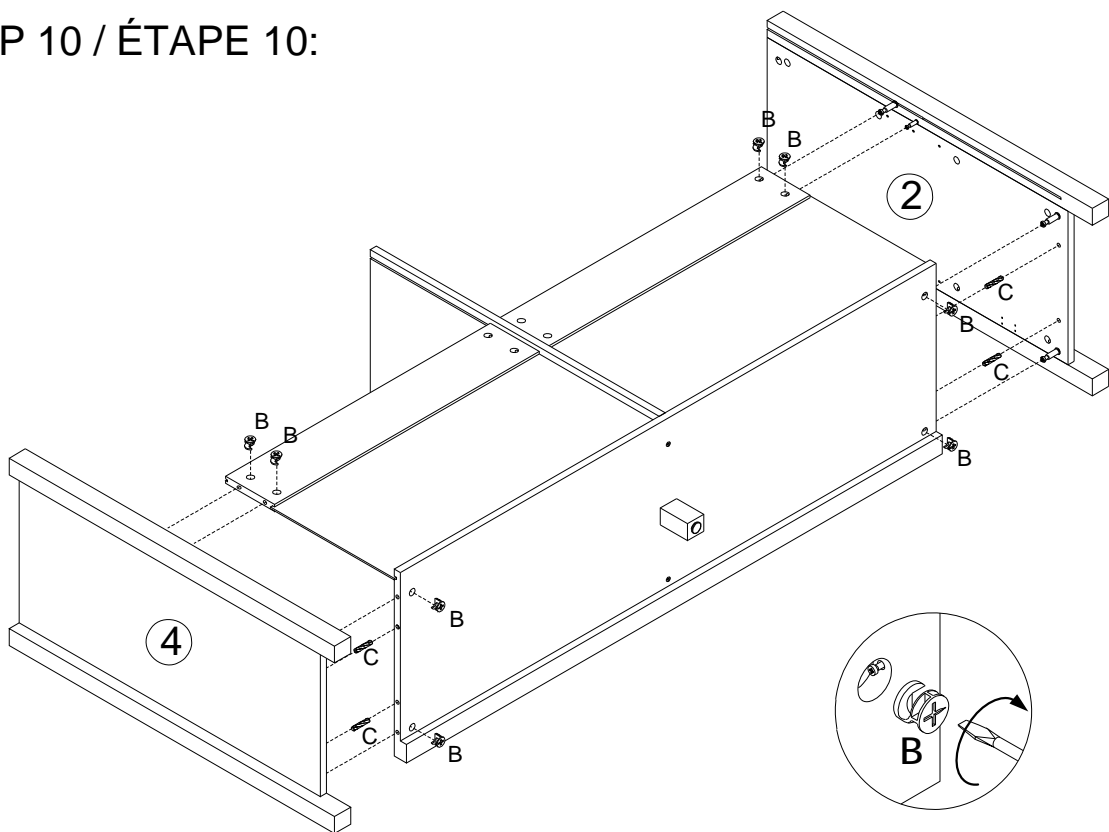

STEP 11 / ÉTAPE 11:

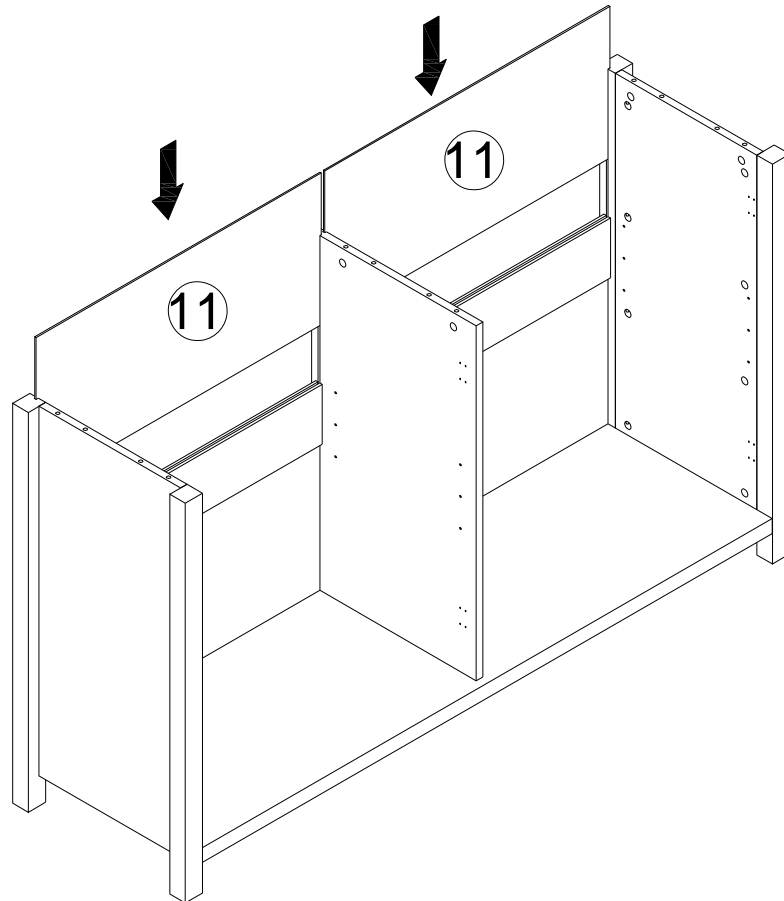

STEP 12 / ÉTAPE 12:

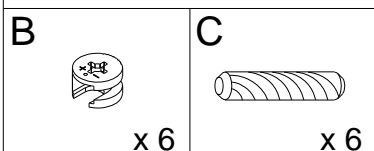
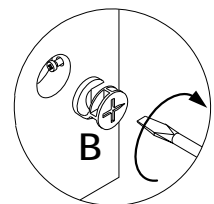
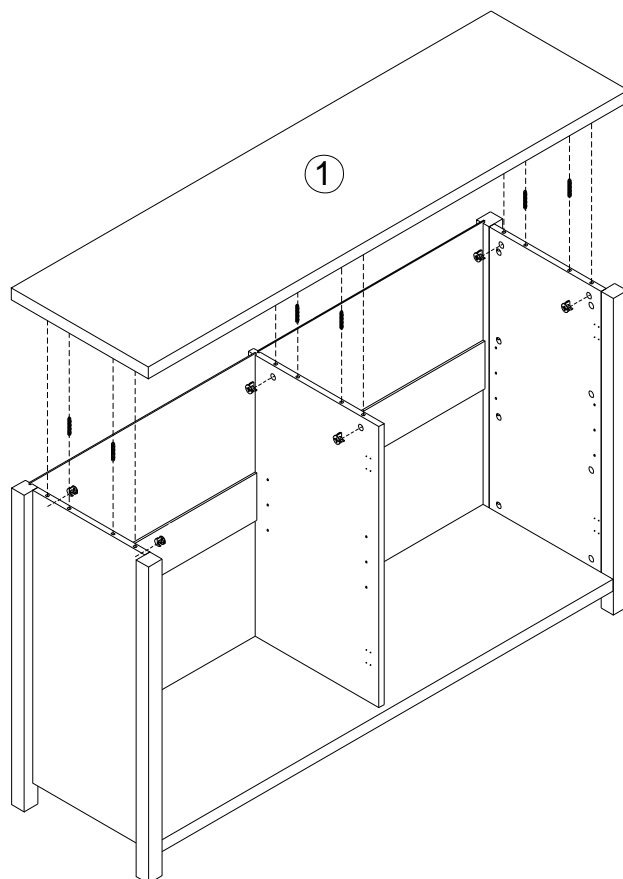

STEP 13 / ÉTAPE 13:

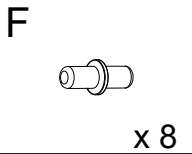
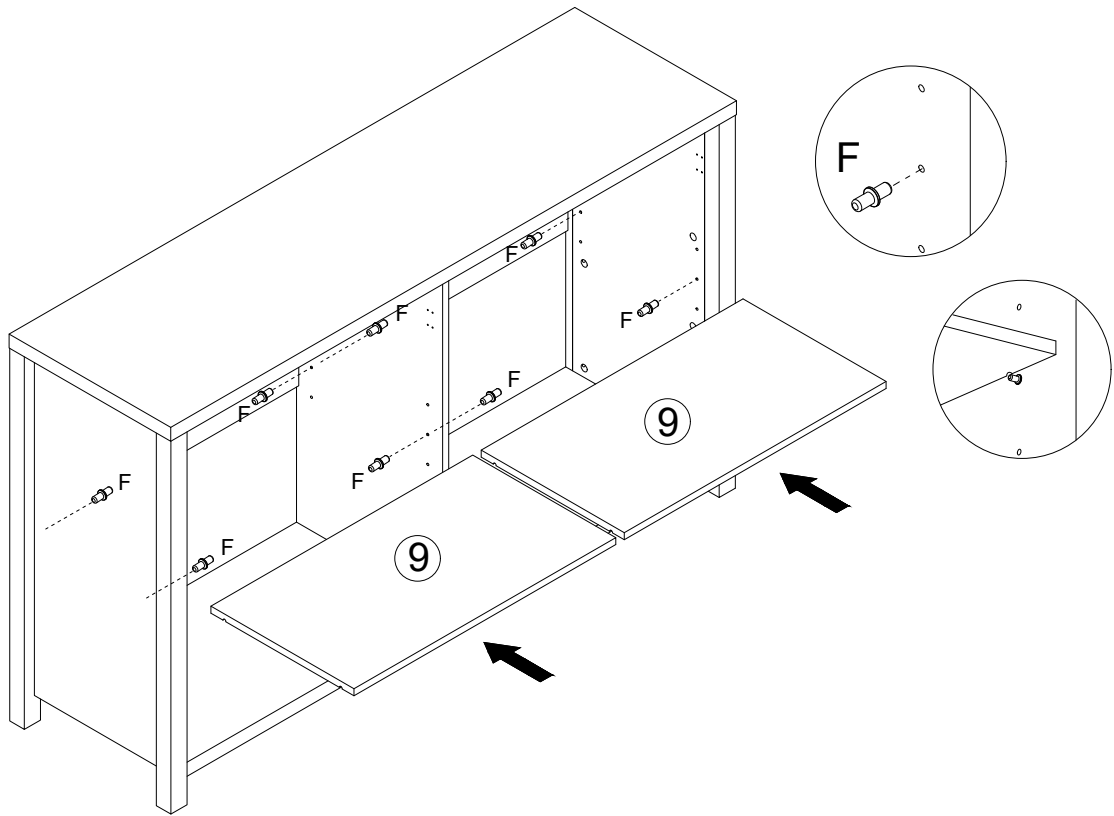

STEP 14 / ÉTAPE 14:

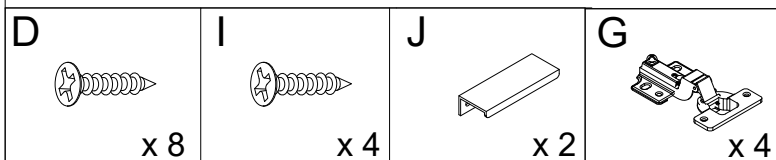
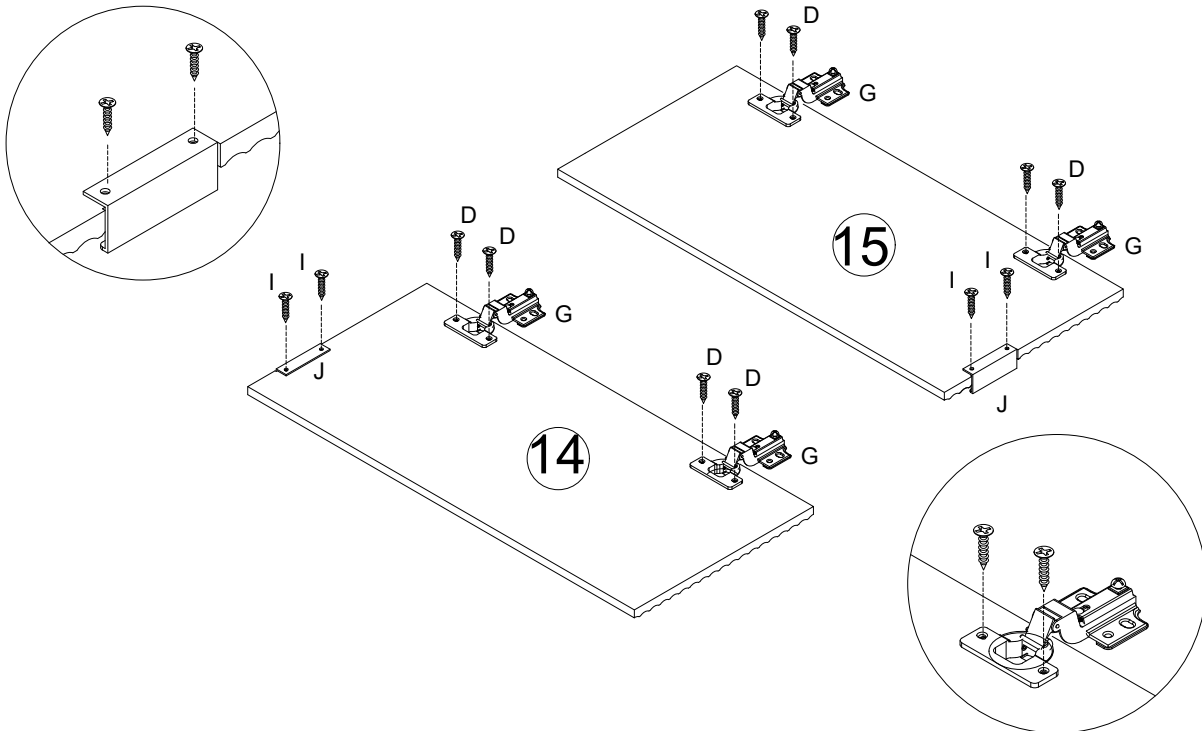

STEP 15 / ÉTAPE 15:

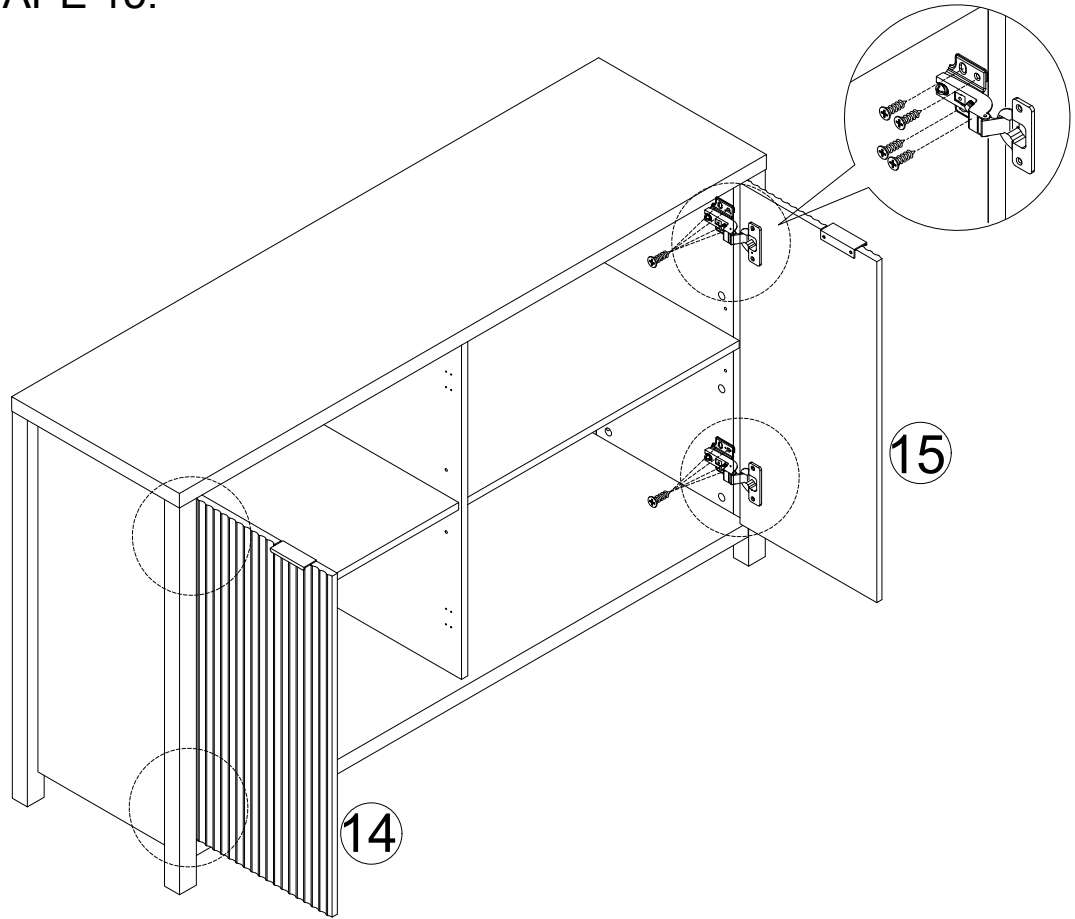

D



x 16

STEP 16 / ÉTAPE 16:

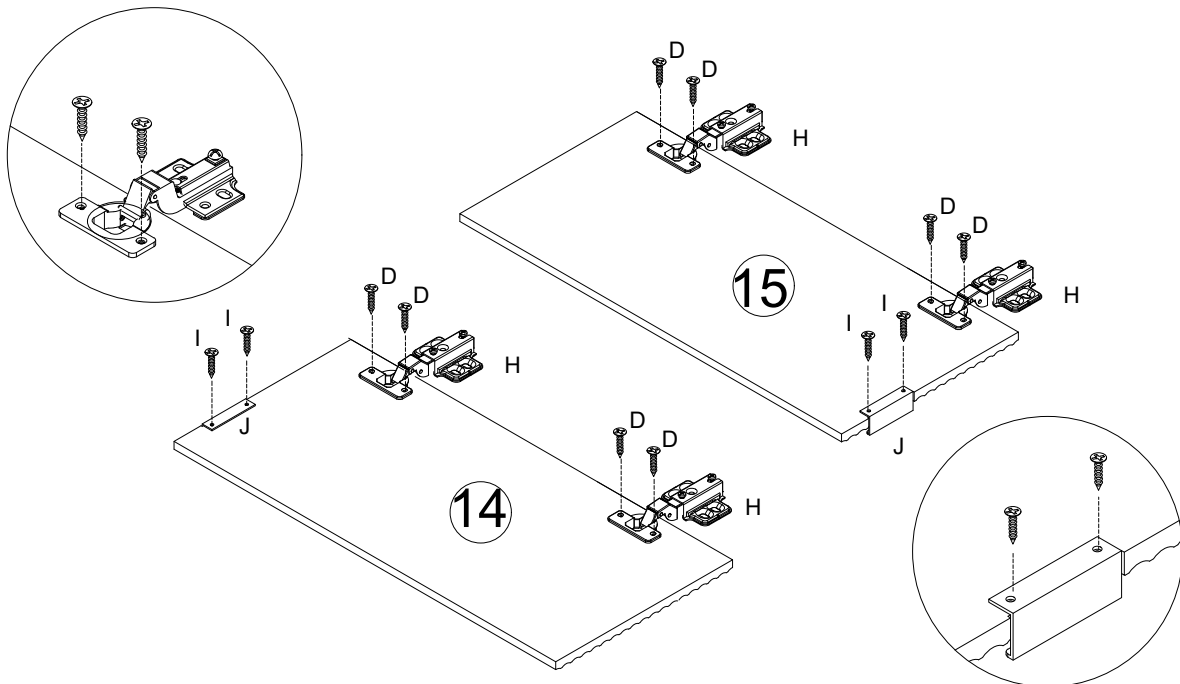

D

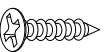

x 8

I



x 4

J



x 2

H



x 4

STEP 17 / ÉTAPE 17:

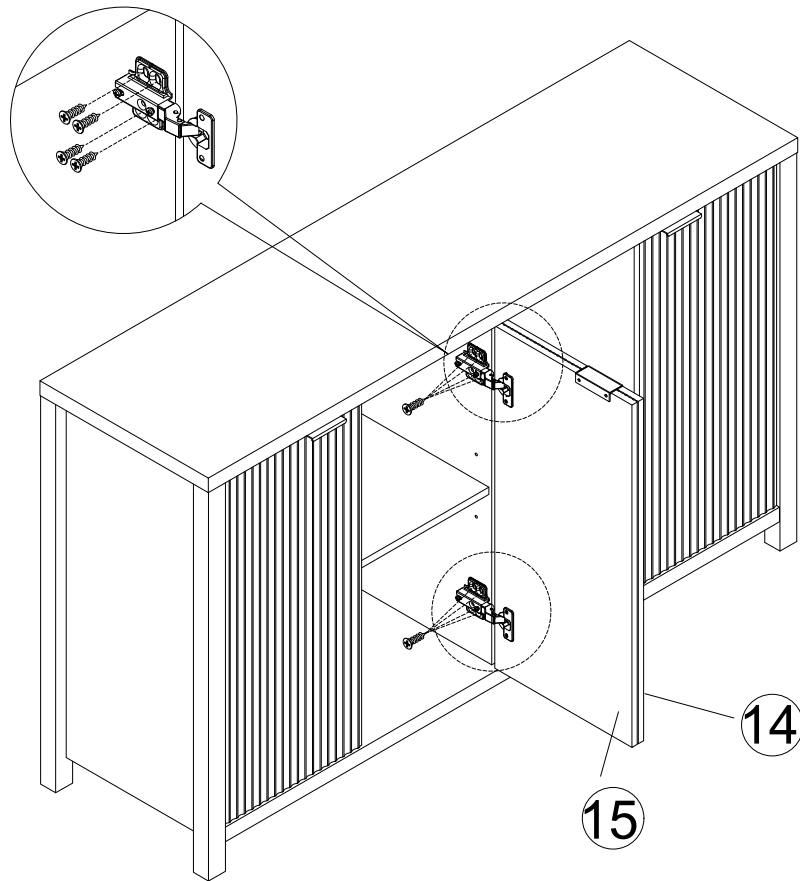

D



x 16

STSTEP 18 / ÉTAPE 18:

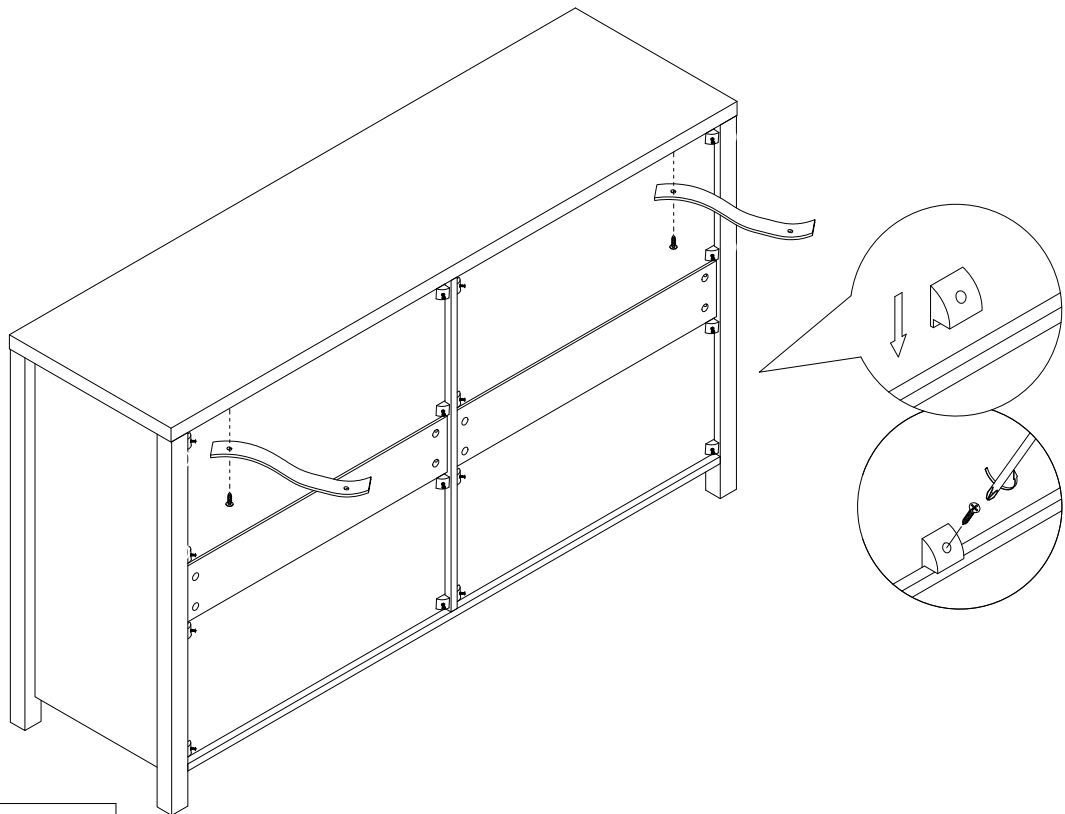

M

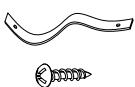

x 2

O



x 16

STEP 19 / ÉTAPE 19:

Wall

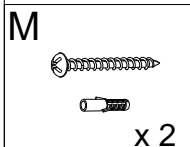
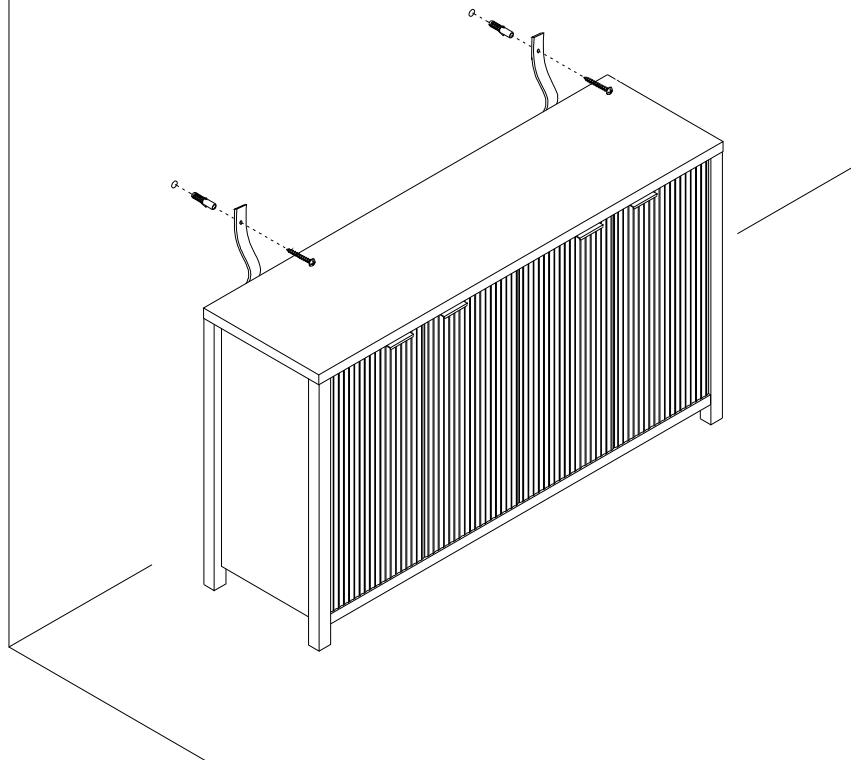

STEP 20 / ÉTAPE 20:

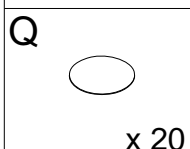
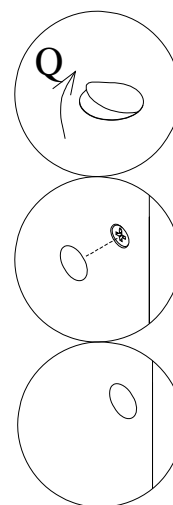
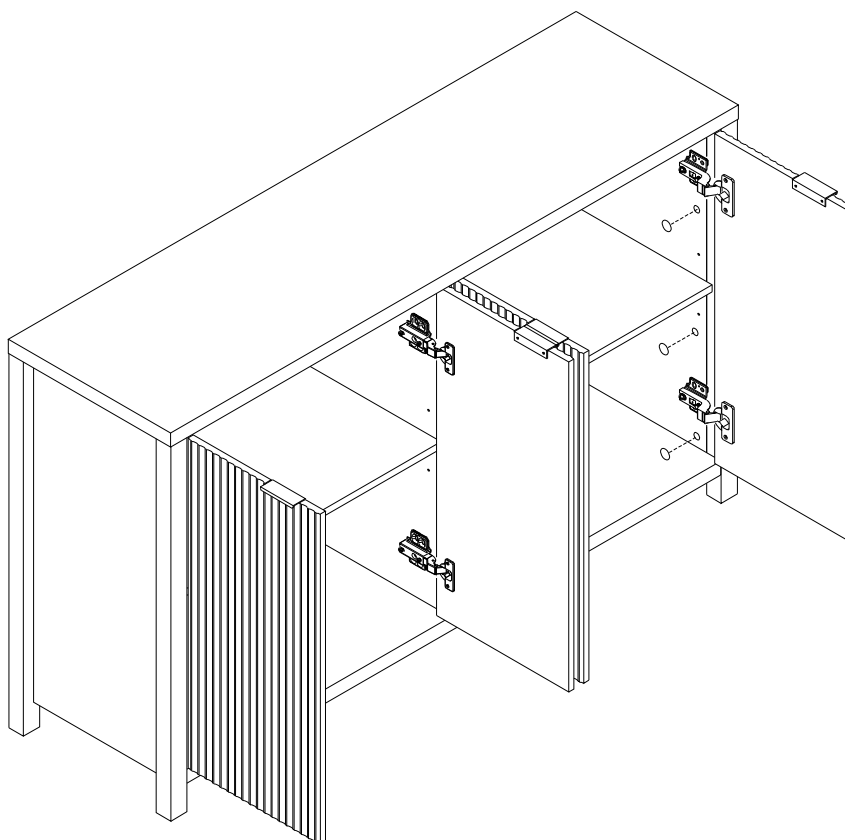

x 20