

SIDE CHAIR ASSEMBLY INSTRUCTIONS

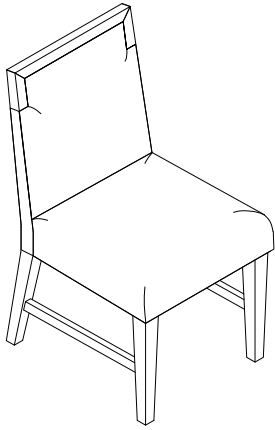

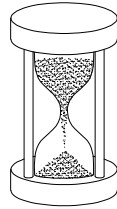





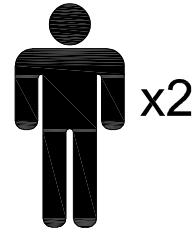

ASSEMBLY INSTRUCTIONS

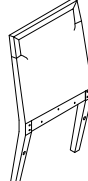

15 MIN

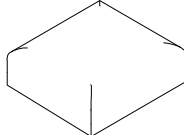

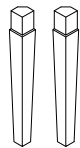

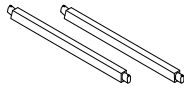

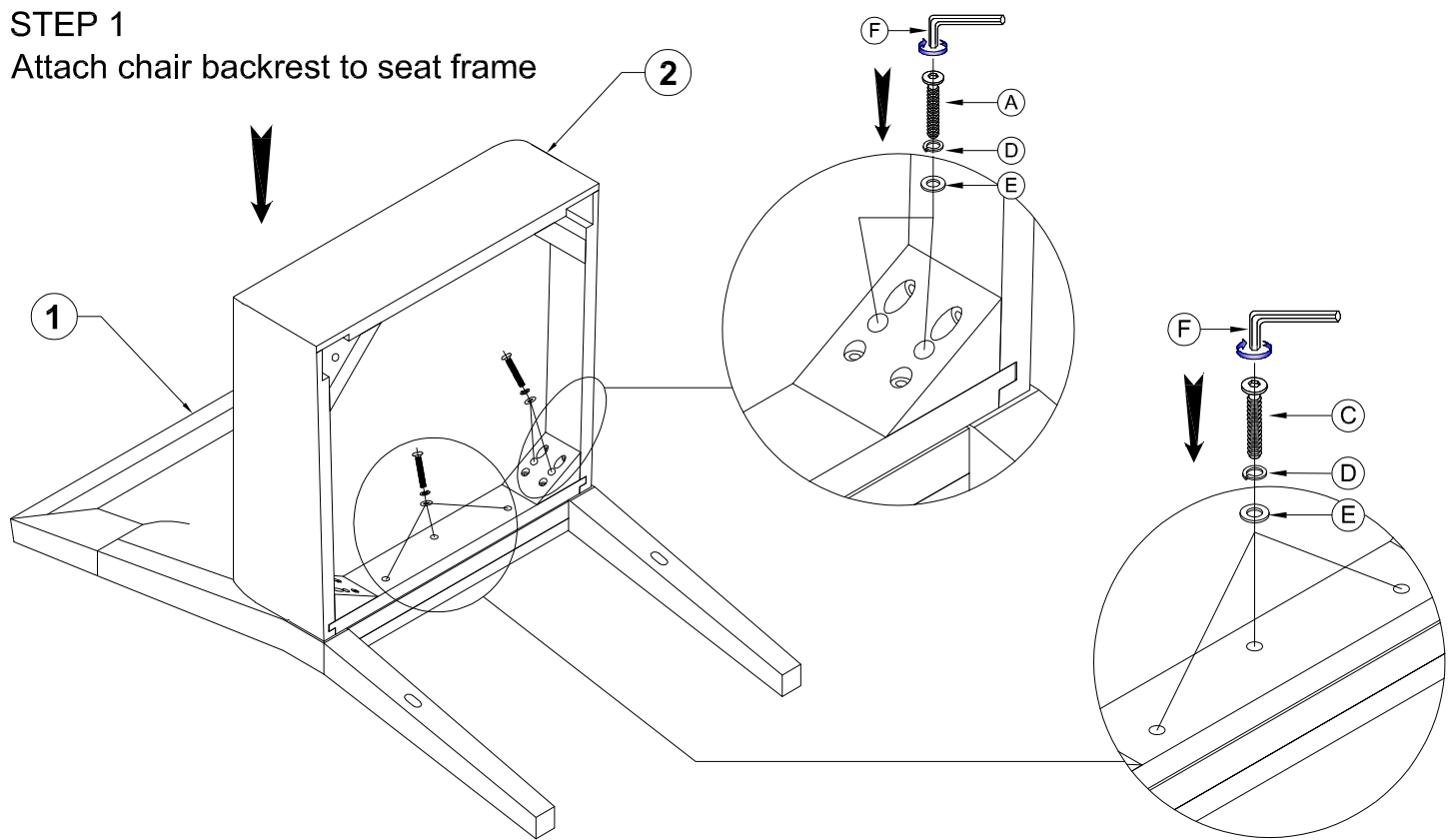

TOOLS REQUIRED
(Allen Key provided)

CARTON	ITEM	PART	HARDWARE
1	I	① CHAIR BACKREST x 1 PC 	(A) M6 x 80 mm: 4 pcs  (B) M6 x 50 mm: 4 pcs  (C) M6 x 40 mm: 3 pcs 
		② SEAT FRAME x 1PC 	(D) Ø6 x Ø10 x 1.2: 11 pcs  (E) Ø6 x Ø19 x 2: 11 pcs 
		③ CHAIR LEGS x 2PCS 	(F) 4mm x 60: 1 pc  (G) M4 x 40 mm: 4 pcs 
		④ SIDE STRETCHERS x 2PCS 	

STEP 1

Attach chair backrest to seat frame



A  M6 x 70 mm : 4 pcs	C  M6 x 40 mm : 3 pcs	D  Ø6 x Ø10 x 1.2 : 7 pcs	E  Ø6 x Ø19 x 2 : 7 pcs	F  4mm x 60 : 1 pc
---	---	--	---	---

STEP 2

Attach the side stretchers and secure it to the legs from the chair-backrest. Use corresponding hardware

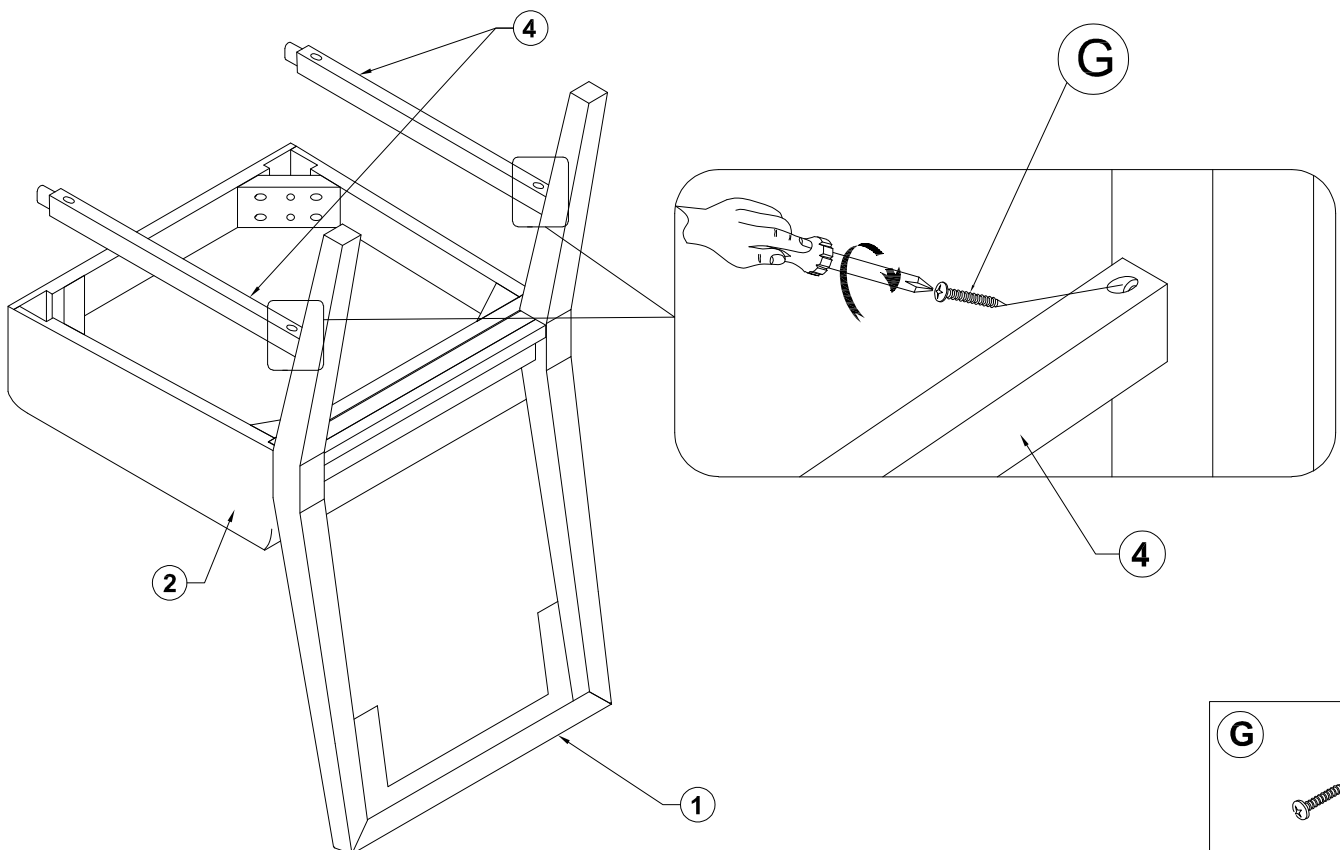



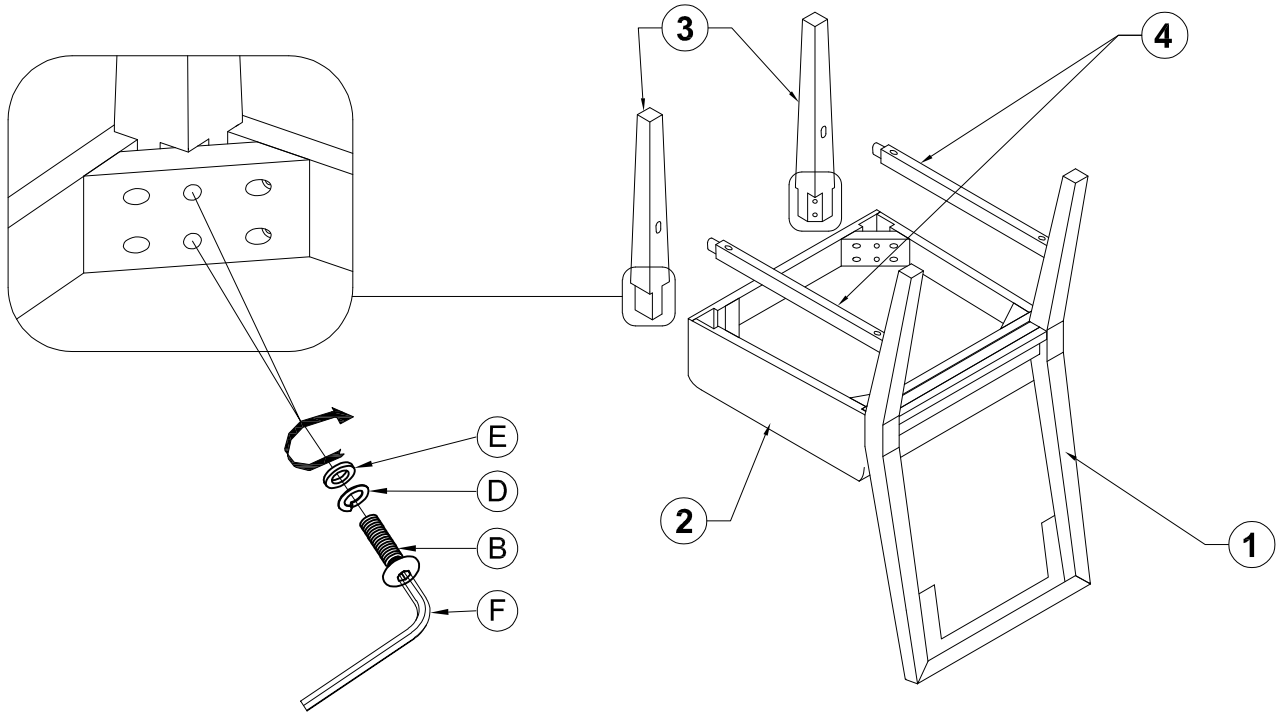

G  M4 x 40 mm : 2 pcs

STEP 3

Attach front chair legs to the seat frame and also connect it to the previously assembled stretchers. Now proceed to secure the legs to the seat frame using corresponding hardware



B  M6 x 50 mm : 4 pcs	D  Ø6 x Ø10 x 1.2 : 4 pcs	E  Ø6 x Ø19 x 2 : 4 pcs	F  4mm x 60 : 1 pc	G  M4 x 40 mm : 4 pcs
--	---	--	---	---

STEP 4

Finally, secure the legs to the stretchers using corresponding hardware

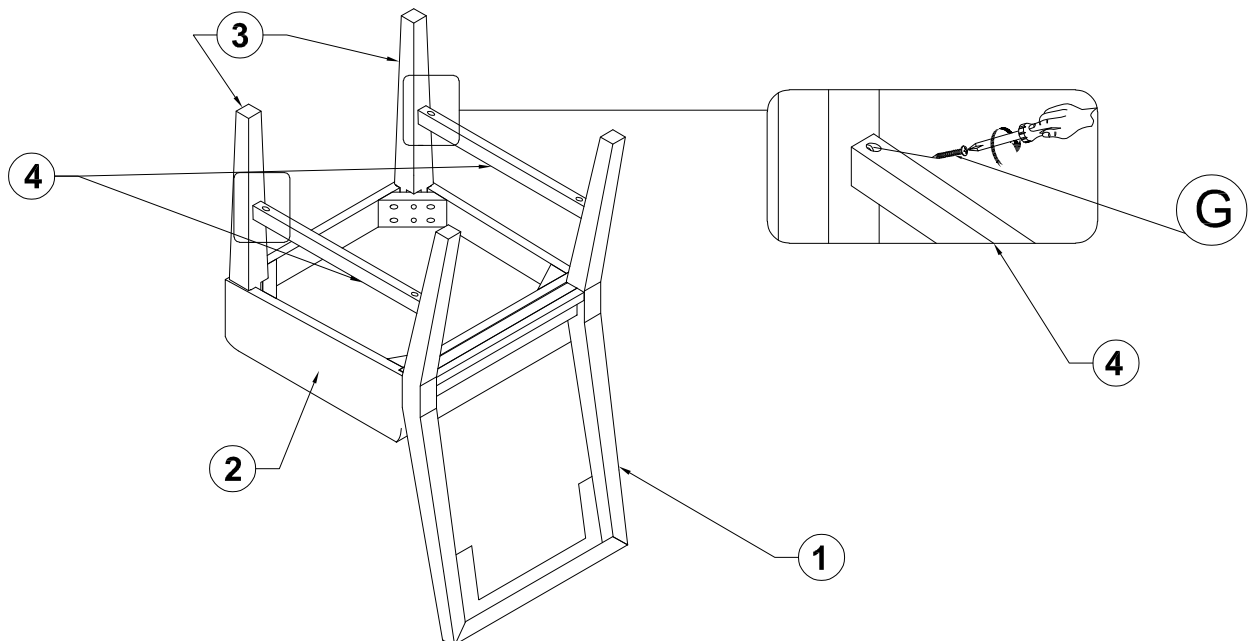

“Important Note - Before finally tightening the bolts, place the assembled chair upright on a level surface and sit carefully on the chair to ensure the chair legs are aligned and leveled. Then tighten all bolts and your chair is ready to be used.”

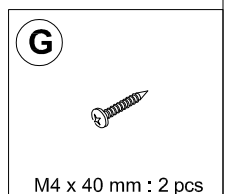

ASSEMBLY COMPLETED



CAUTION ! : REQUIRES TWO ADULTS TO FLIP AND TURN CHAIR UPRIGHT AFTER ASSEMBLY IS FINISHED.