

ASSEMBLY INSTRUCTION

Thank you for purchasing this quality product. Be sure to check all packing material carefully for small parts that may have come loose inside the carton during shipment.

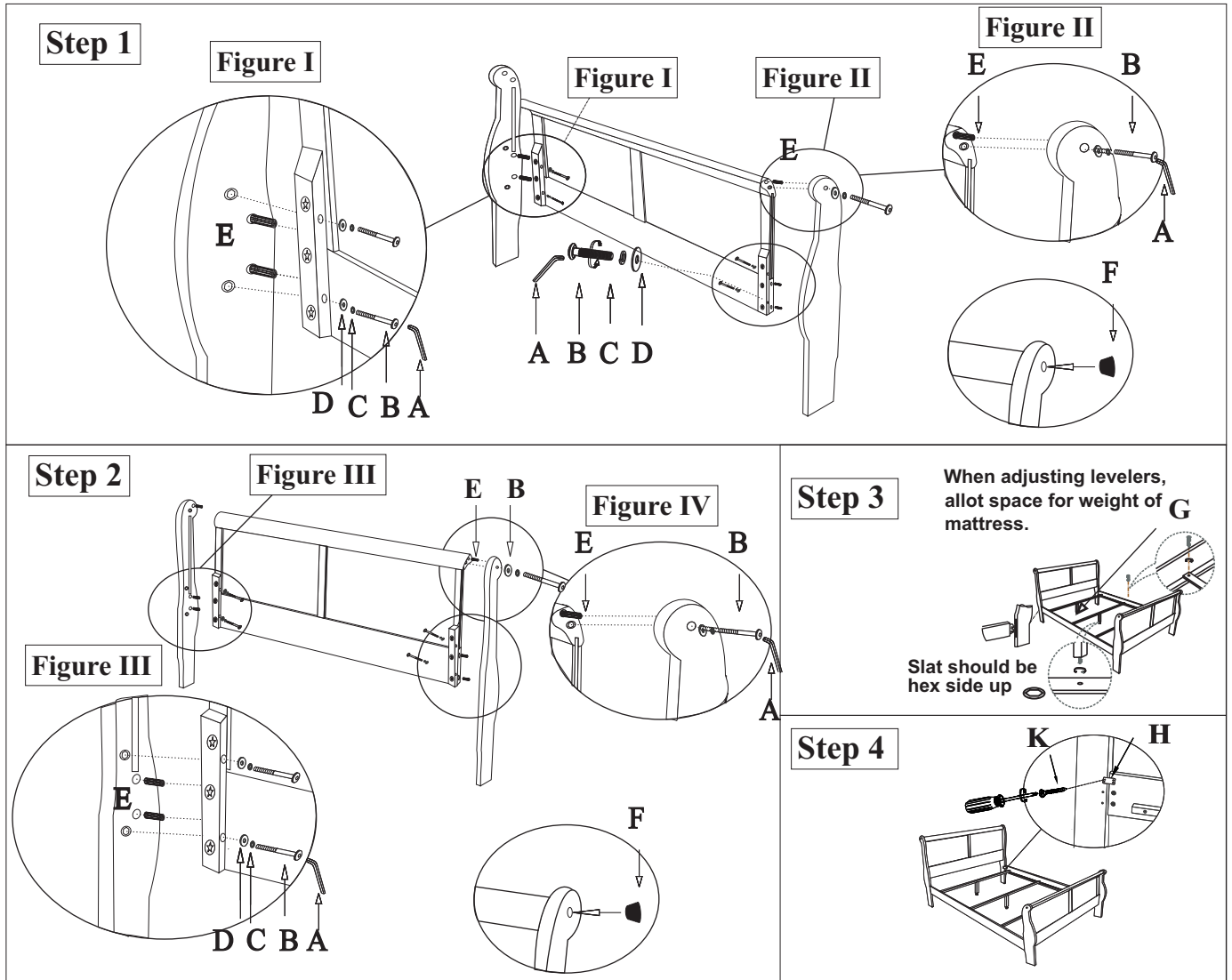

Step	No.	Hardware	Qty
1 & 2	A	Allen wrench 4mm	1
	B	Bolt 1/4 x32mm	12
	C	Spring Washer 1/4"	12
	D	Washer 1/4"x14x2	12
	E	Wood Dowel 10.7x30	12
	F	Wood Plug 16.3x6	4
3	G	Wood Screw 4x35	6
4	H	Iron 60x40	4
	K	Wood Screw 3.5x15	16

Part List

MADE IN VIETNAM