





ASSEMBLY INSTRUCTION

Read this instruction carefully. Remove all wrapping material, staples and straps from the carton.
See hardware and furniture part list
For guidance. Be sure you have all wooden furniture parts on a clean and flat soft surface, such as a carpet or rug, to prevent from being scratched. Follow the figure to start assembling.

CAUTION :

1. Do not FULLY - TIGHTEN the nut or screw until all is ready to assemble.
2. Do not OVER - TIGHTEN the nut or screw to avoid causing damages to the thread.
3. Keep all hardware part out reach of children.

NO	PART LIST	QTY
A	BACK REST	1 PC
B	FRONT LEG	1 PC
C	SIDE RAIL	2 PCS
D	CUSHION SEAT	1 PC

NO	DESCRIPTION	QTY
1	JCBC SCREW M6 X 50MM 	6 PCS
2	WOOD DOWEL Ø8 x 30MM 	4 PCS
3	CSK SCREW M4 x 30MM 	3 PCS
4	SPRNG WASHER M6 	6 PCS
5	M4 ALLEN KEY 	1 PC

STEP 1

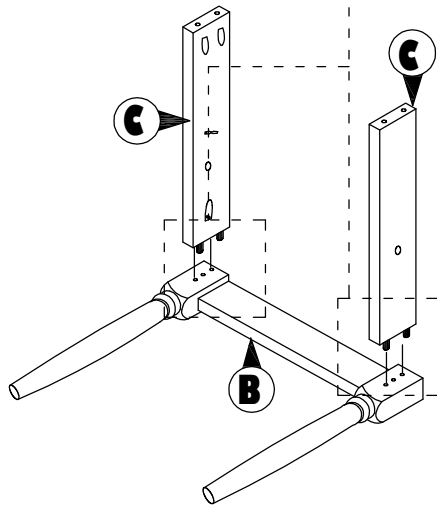
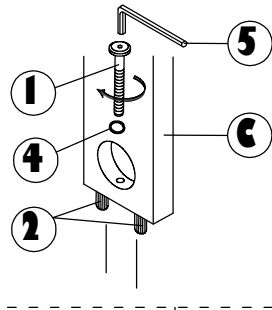

STEP 2

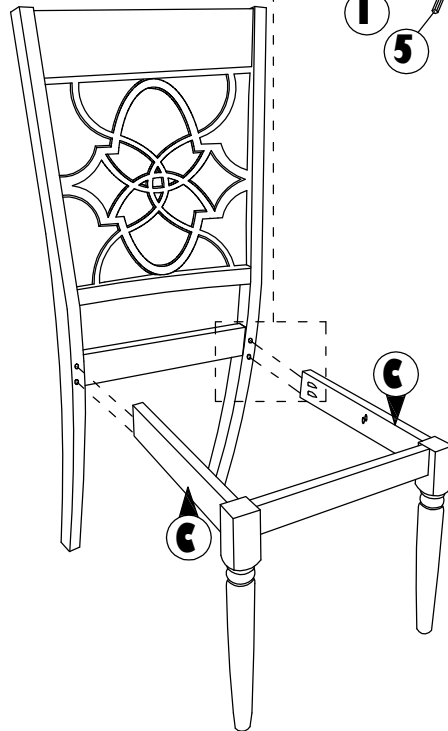
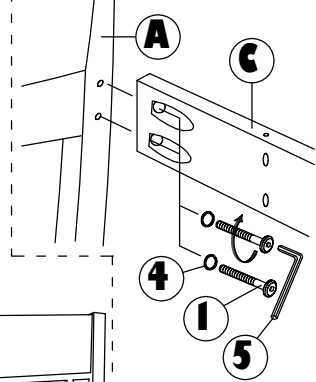

STEP 3

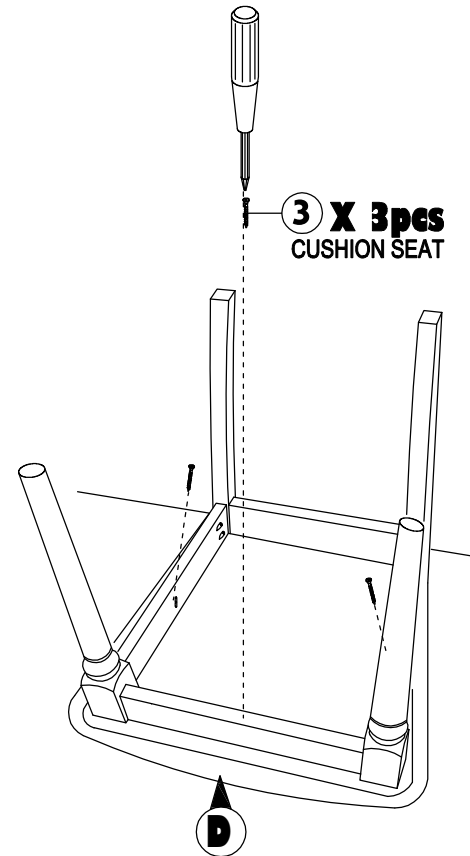

STEP 4

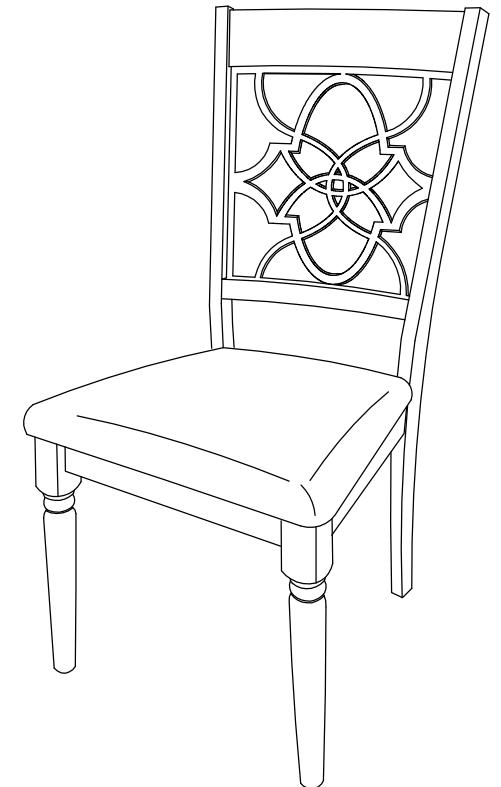

COMPELETE ASSEMBLE

ASSEMBLY INSTRUCTION





MODEL : 7208T / 7208-1T

Read this instruction carefully. Remove all wrapping material, staples and straps from the carton. See hardware and furniture part list for guidance. Be sure you have all wooden furniture parts on a clean and flat soft surface, such as a carpet or rug, to prevent from being scratched. Follow the figure to start assembling.

CAUTION :

1. Do not FULLY - TIGHTEN the nut or screw until all is ready to assemble.
2. Do not OVER - TIGHTEN the nut or screw to avoid causing damages to the thread.
3. Keep all hardware part out reach of children.

NO	PART LIST	QTY
A	TABLE TOP	1 PC
B	PEDESTAL TABLE CENTER	1 PC
C	PEDESTAL LEGS	4 PCS
D	CROSS BAR 'X'	2 PCS
E	BOX COVER	1 PC

NO	DESCRIPTION	QTY
1	CSK SCREW M4 X 30MM 	16 PCS
2	HEX. NUT 	8 PCS
3	FLAT WASHER 	8 PCS
4	SPANNAR 	1 PC
5	ADJUSTER 	4 PCS

STEP 1.1

Firstly, connect C to B according to the hole using hardware number 2, 3 and 4.

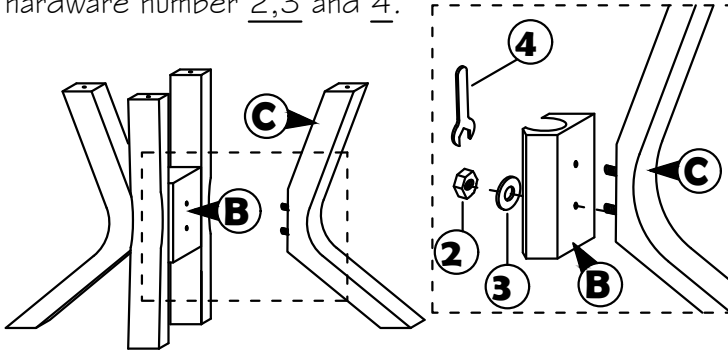

STEP 1.2

Then, attached 4 pieces hardware number 5 to part C.

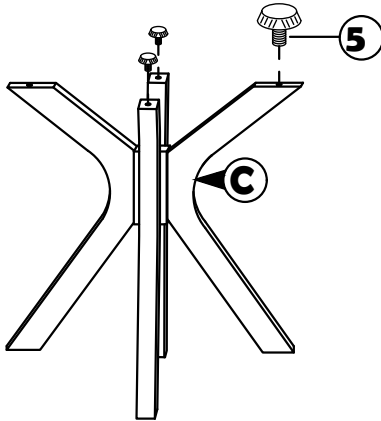

STEP 2.1

Put part E to B align to the nut provided.

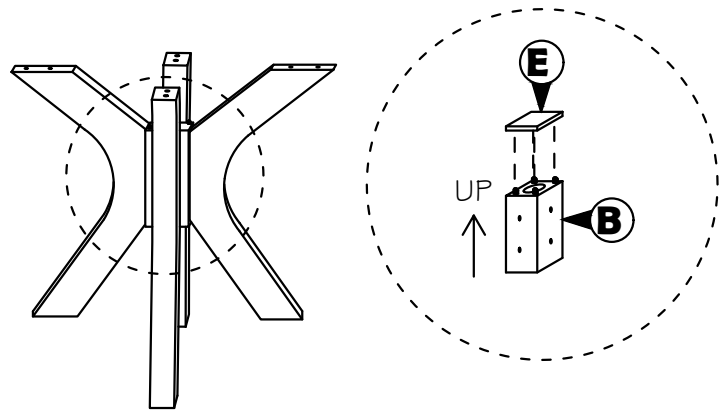

STEP 2.2

Align part D to C accordingly and tighten it using hardware number 1.

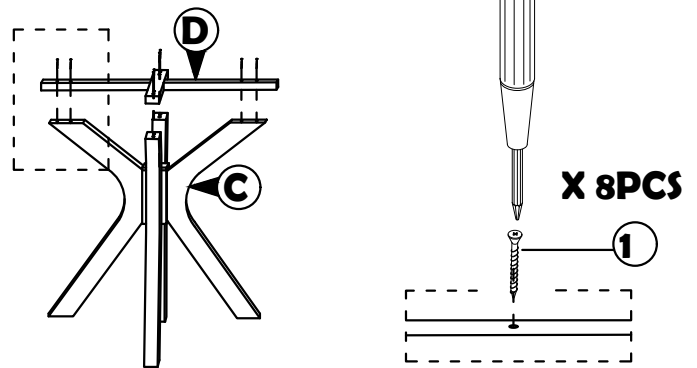

STEP 4

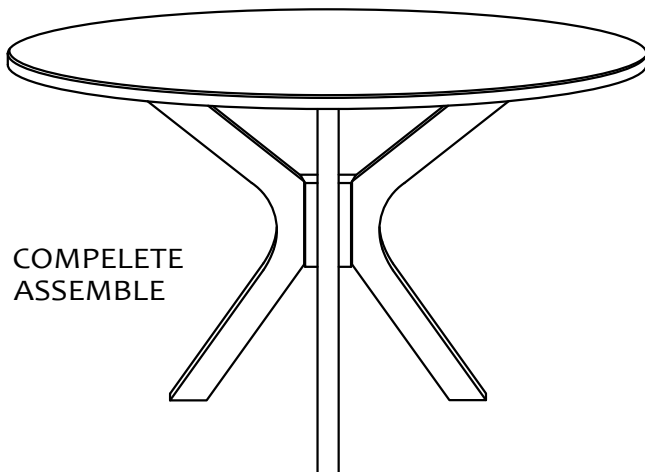

STEP 3

Align part D to A compatible with the hole provided. Please make sure the hole for both part D and A are align before tighten it using hardware number 1.

