

We're here for you. Contact us at support.us@soforoom.com



X3

Outdoor Patio Furniture Set

Model:WR413-US
NO.:

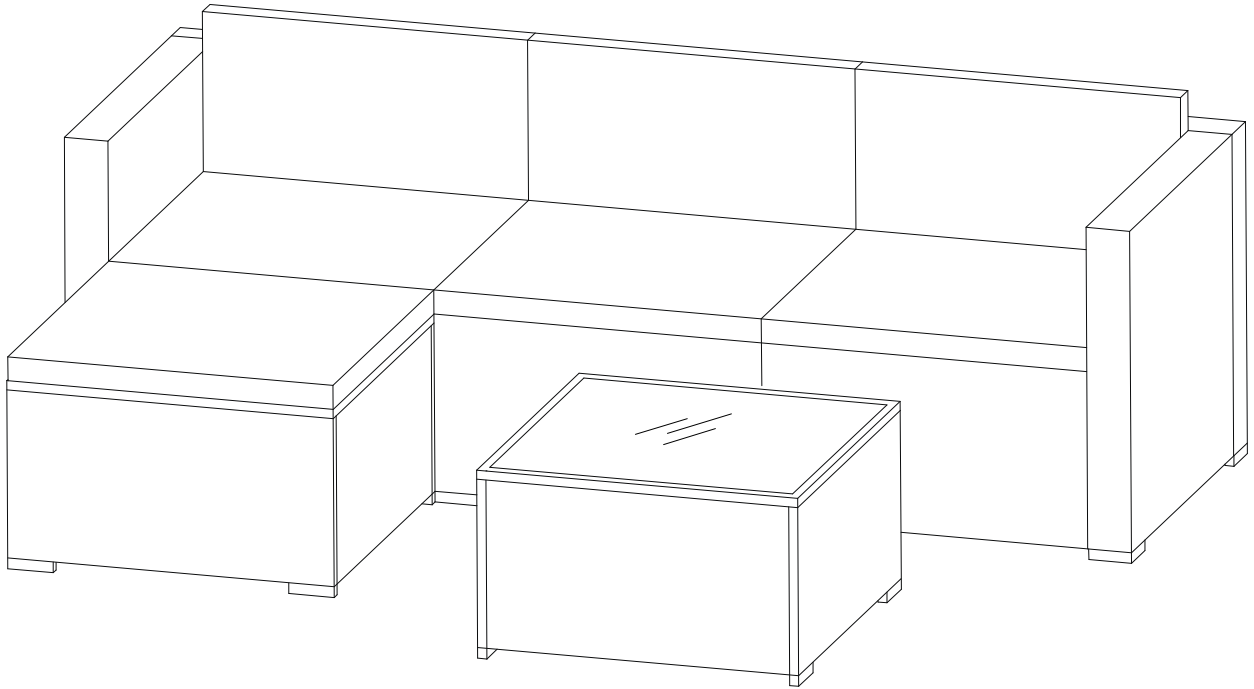

HELP CENTER

Have questions about this product? Contact us, and we'll assist you!

● Customer Support Email:

support.us@soforoom.com

* Upon receiving your email, we'll respond within 48 working hours.

CENTRO DE AYUDA

¿Tienes preguntas sobre tu producto? Ponte en contacto con nosotros y te ayudaremos.

● Correo electrónico de atención al cliente:

support.us@soforoom.com

*Al recibir tu correo electrónico, te responderemos en un plazo de 48 horas laborables.

FAQ

Q1: What should I do if the product I received is damaged or incorrect?

A1: If you've received a damaged, incorrect, or incomplete product, please reach out to our Customer Support Center at support.us@soforoom.com. Include your order number and photos.

Q2: What should I do if I encounter problems during installation?

A2: If you encounter any installation issues, please email to support.us@soforoom.com, attach a detailed description of the problem, we will provide you for professional technical support.

Q3: How do I apply a return?

A3: You can initiate a return within 30 days of purchase. Email us at support.us@soforoom.com with your order number and the reason for return. We'll guide you through the process.

Note:

- . Please contact us before returning the product to avoid any complications.
- . Ensure the product is returned in its original packaging with all accessories included.

PREGUNTAS FRECUENTES

P1: ¿Qué debo hacer si el producto que he recibido está dañado o es incorrecto?

R1: Si has recibido un producto dañado, incorrecto o incompleto, ponte en contacto con nuestro Centro de Atención al Cliente en support.us@soforoom.com. Incluye tu número de pedido y fotos que documenten el problema para que podamos ayudarte con la devolución o el cambio.

P2: ¿Qué debo hacer si encuentro problemas durante la instalación?

R2: Si tienes algún problema durante la instalación, por favor envía un correo electrónico a support.us@soforoom.com, adjuntando una descripción detallada del problema.

Te proporcionaremos soporte técnico profesional.

P3: ¿Cómo puedo solicitar una devolución?

R3: Puede iniciar una devolución en los 30 días siguientes a la compra. Envíenos un correo electrónico a support.us@soforoom.com con su número de pedido y el motivo de la devolución. Te guiaremos a través del proceso.

Nota:

- . Póngase en contacto con nosotros antes de devolver el producto para evitar complicaciones.
- . Asegúrate de devolver el producto en su embalaje original y con todos los accesorios incluidos.

Product Guide and Maintenance Instructions

EN

Thank you for purchasing our product! To ensure a smooth installation and optimal user experience, we recommend that you carefully read the following guide and instructions before starting.

Assembly Instructions:

- Before installation, inspect all parts and accessories to confirm that none are damaged or missing. If any issues are found, please contact us promptly.
- Assemble the product in a spacious and flat area to ensure sufficient space for moving parts, avoid accidental collisions, and facilitate the assembly process.
- It is advisable to refer to the schematic diagrams during assembly to make the process easier. Align all screws with the corresponding pre-drilled holes, then tighten each screw one by one after all parts are correctly positioned.
- When tightening screws during assembly, pay attention to the force applied. If any parts are damaged, please contact us promptly.
- After installation, check all connection points to ensure there are no loose parts. Adjust and tighten as necessary to ensure the product's stability.

Safety Warnings:

- Children are not allowed to assemble this product. During assembly, keep all small parts out of reach of children.
- Do not allow children to climb on or play with the product to prevent serious injuries from tipping.

Usage Restrictions:

- Ensure the product is placed on a flat surface. Do not stand on or jump on the sofa or chair.
- Avoid placing sharp objects on the sofa to prevent damage to the rattan material.

Product Usage:

- This product is suitable for both indoor and outdoor use.
- We are not responsible for any damage caused by unintended use or modifications.

Product Maintenance:

● Environmental Conditions

The product is designed for outdoor use; however, avoid using it in extreme weather conditions, such as storms or prolonged exposure to direct sunlight, as this may cause material fading or damage.

● Regular Maintenance

Regularly check the product's stability and connection points to ensure screws are not loose.

● Cleaning

For daily cleaning, wipe the rattan seat with a damp cloth and dry it immediately to prevent water damage. The cushion covers are removable for cleaning.

By following these guidelines, you can enjoy a safe and pleasant product experience. Thank you for choosing our product!

Guía del Producto e Instrucciones de Mantenimiento

ES

¡Gracias por adquirir nuestro producto! Para garantizar una instalación sencilla y una experiencia óptima, le recomendamos leer atentamente la siguiente guía e instrucciones antes de comenzar.

Instrucciones de Montaje

- Antes de la instalación, inspeccione todas las piezas y accesorios para confirmar que no haya daños ni faltantes. Si encuentra algún problema, contáctenos de inmediato.
 - Ensamble el producto en un área espaciosa y plana para garantizar suficiente espacio para las piezas móviles, evitar colisiones accidentales y facilitar el proceso de montaje.
 - Se recomienda seguir los diagramas esquemáticos durante el ensamblaje para simplificar el proceso. Alinee todos los tornillos con los orificios pre-perforados correspondientes y, una vez que todas las piezas estén correctamente posicionadas, apriete cada tornillo uno por uno.
 - Al apretar los tornillos durante el montaje, preste atención a la fuerza aplicada. Si alguna pieza está dañada, contáctenos de inmediato.
- Después de la instalación, verifique todos los puntos de conexión para asegurarse de que no haya piezas sueltas. Ajuste y apriete según sea necesario para garantizar la estabilidad del producto.

Advertencias de Seguridad

- Los niños no deben ensamblar este producto. Durante el montaje, mantenga todas las piezas pequeñas fuera del alcance de los niños.
- No permita que los niños se suban o jueguen con el producto para evitar lesiones graves por vuelco.

Restricciones de Uso

- Asegúrese de colocar el producto sobre una superficie plana. No se pare ni salte sobre el sofá o la silla.
- Evite colocar objetos afilados sobre el sofá para prevenir daños en el material de ratán.

Uso del Producto

- Este producto es adecuado tanto para uso en interiores como en exteriores. No nos hacemos responsables de los daños causados por un uso no previsto o modificaciones.

Mantenimiento del Producto

- Condiciones Ambientales
- El producto está diseñado para uso en exteriores; sin embargo, evite su exposición a condiciones climáticas extremas, como tormentas o una exposición prolongada a la luz solar directa, ya que esto podría provocar decoloración o daños en los materiales.

- Mantenimiento Regular
- Revise periódicamente la estabilidad del producto y los puntos de conexión para asegurarse de que los tornillos no estén sueltos.

- Limpieza
- Para la limpieza diaria, limpie el asiento de ratán con un paño húmedo y séquelo inmediatamente para evitar daños por humedad. Las fundas de los cojines son extraíbles para su lavado.

Siguiendo estas recomendaciones, podrá disfrutar de una experiencia segura y satisfactoria con nuestro producto.

¡Gracias por elegir nuestro producto!

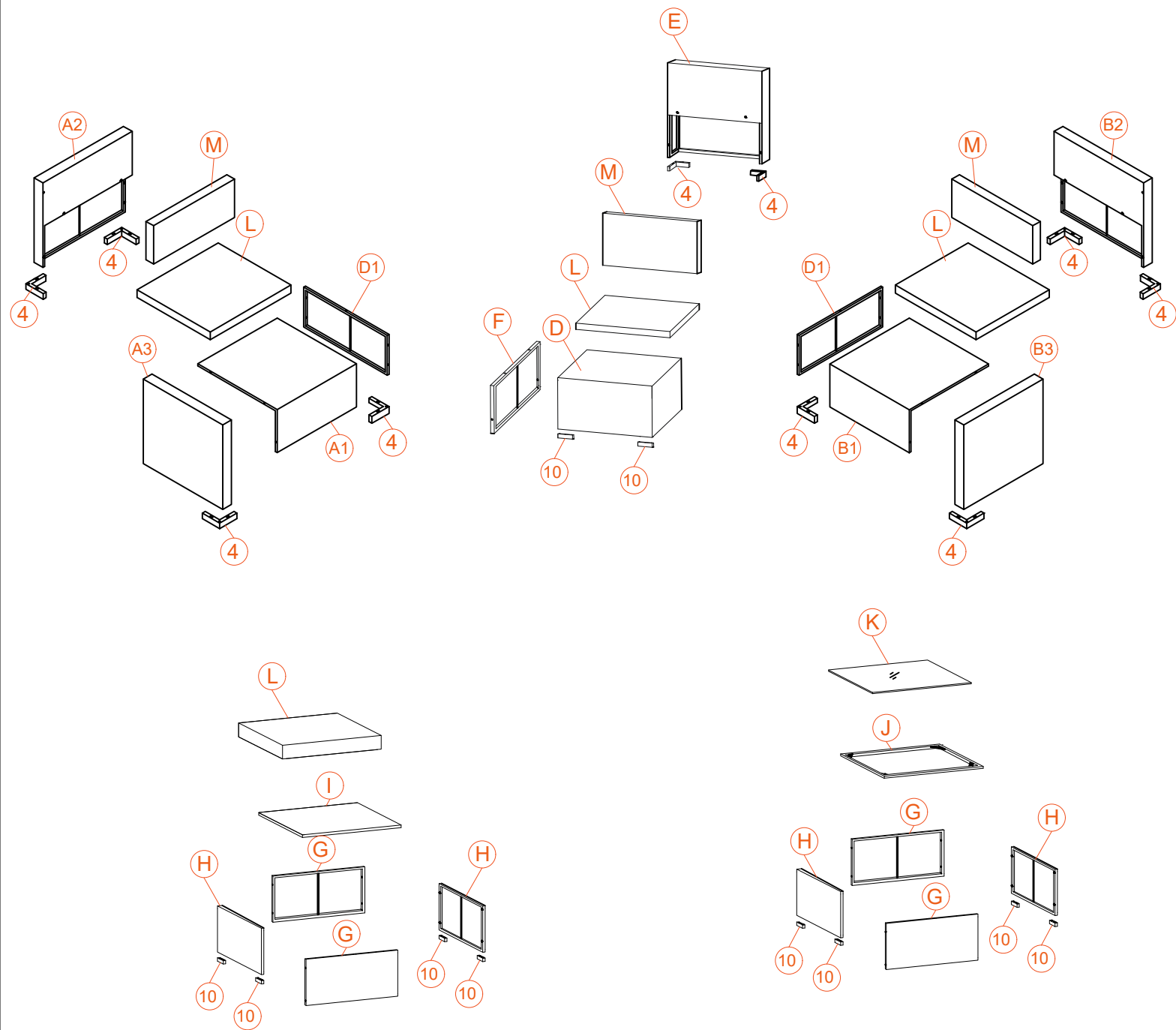

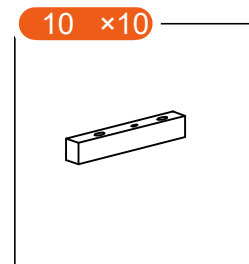
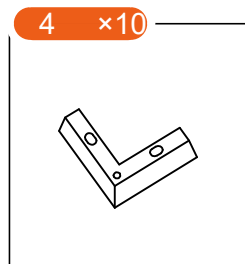
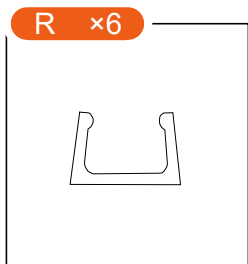
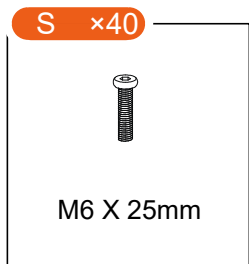
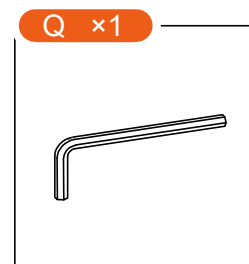
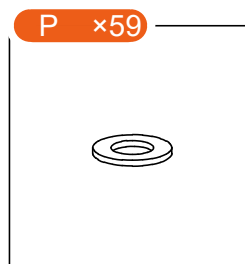
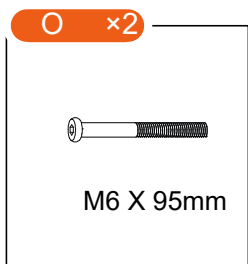
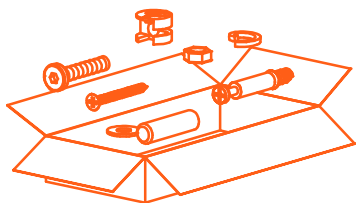

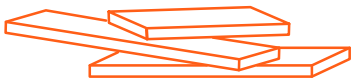

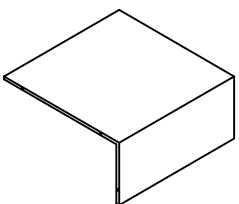
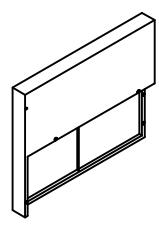
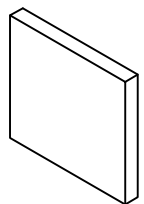
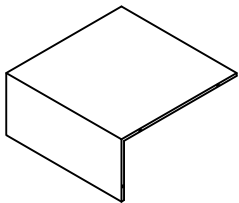
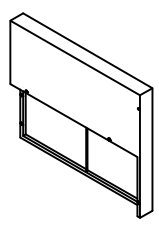
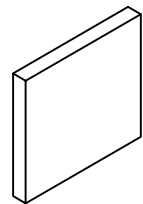
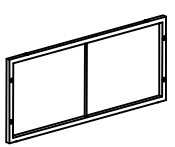
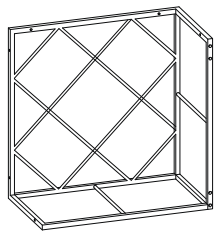
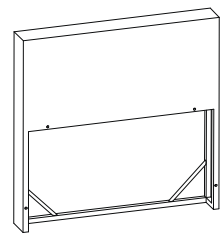
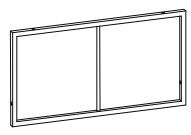
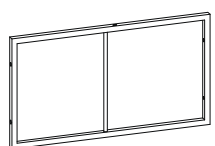
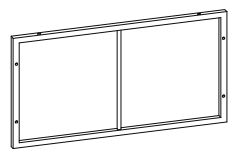
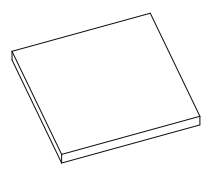
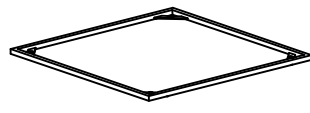
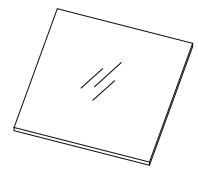
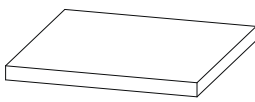
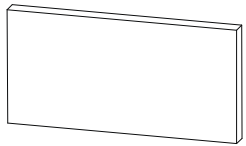
<p>(A1) x1</p> <p>x1</p> 	<p>(A2) x1</p> 	<p>(A3) x1</p> <p>x1</p> 
<p>(B1) x1</p> 	<p>(B2) x1</p> 	<p>(B3) x1</p> 
<p>(D1) x2</p> 	<p>(D) x1</p> 	<p>(E) x1</p> 
<p>(F) x1</p> 	<p>(G) x4</p> 	<p>(H) x4</p> 
<p>(I) x1</p> 	<p>(J) x1</p> 	<p>(K) x1</p> 
<p>(L) x4</p> 	<p>(M) x3</p> 	

1

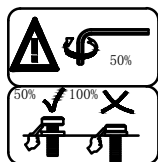

Please screw the parts together at 50% loose, it will help you assemble the sets easily.

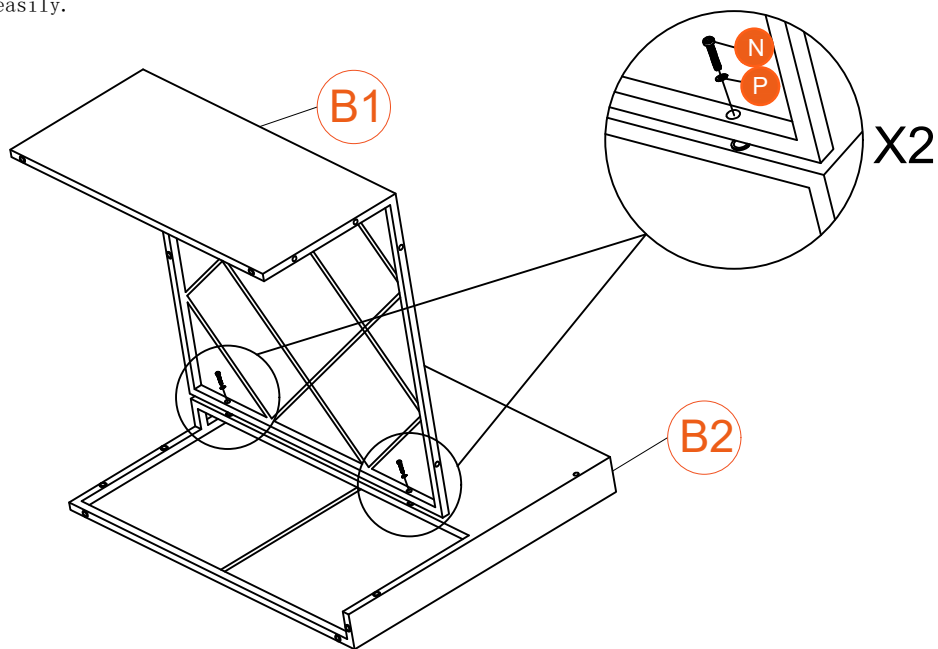

2

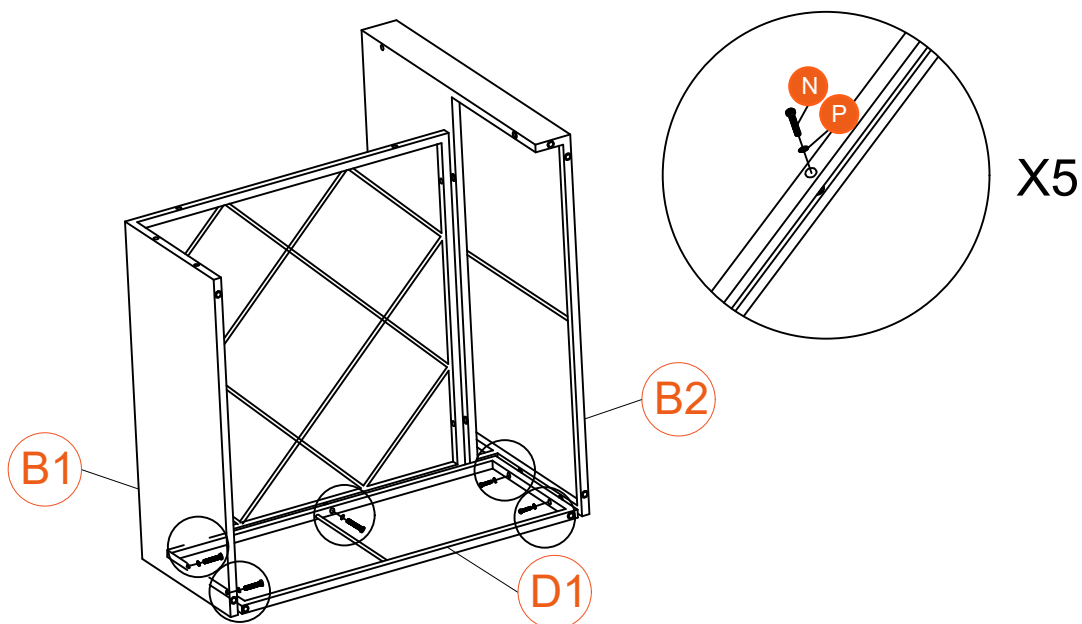
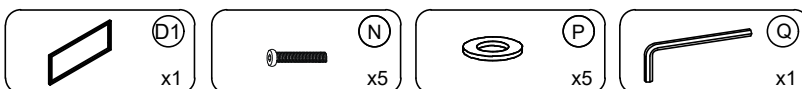

3

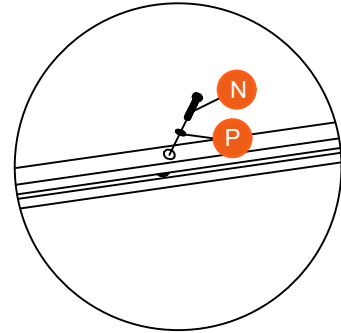
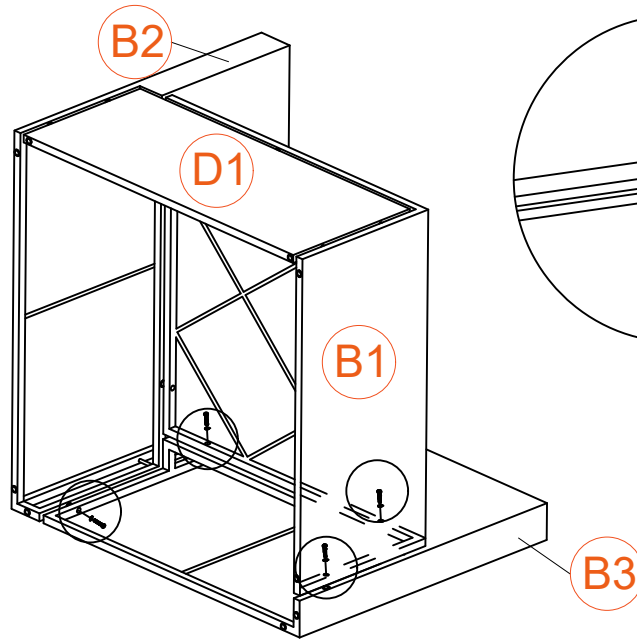
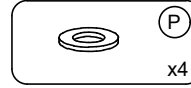
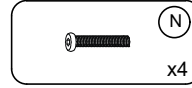
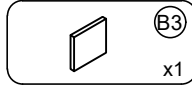

X4

4

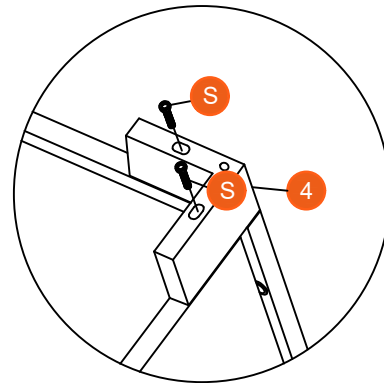
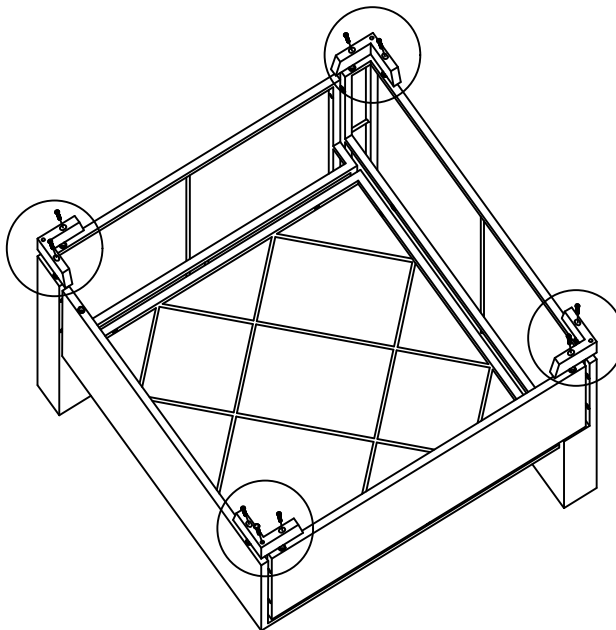
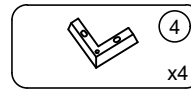
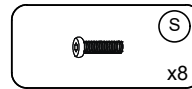

X4

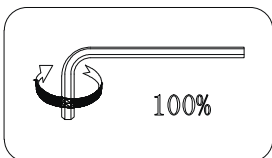

5

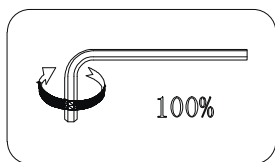
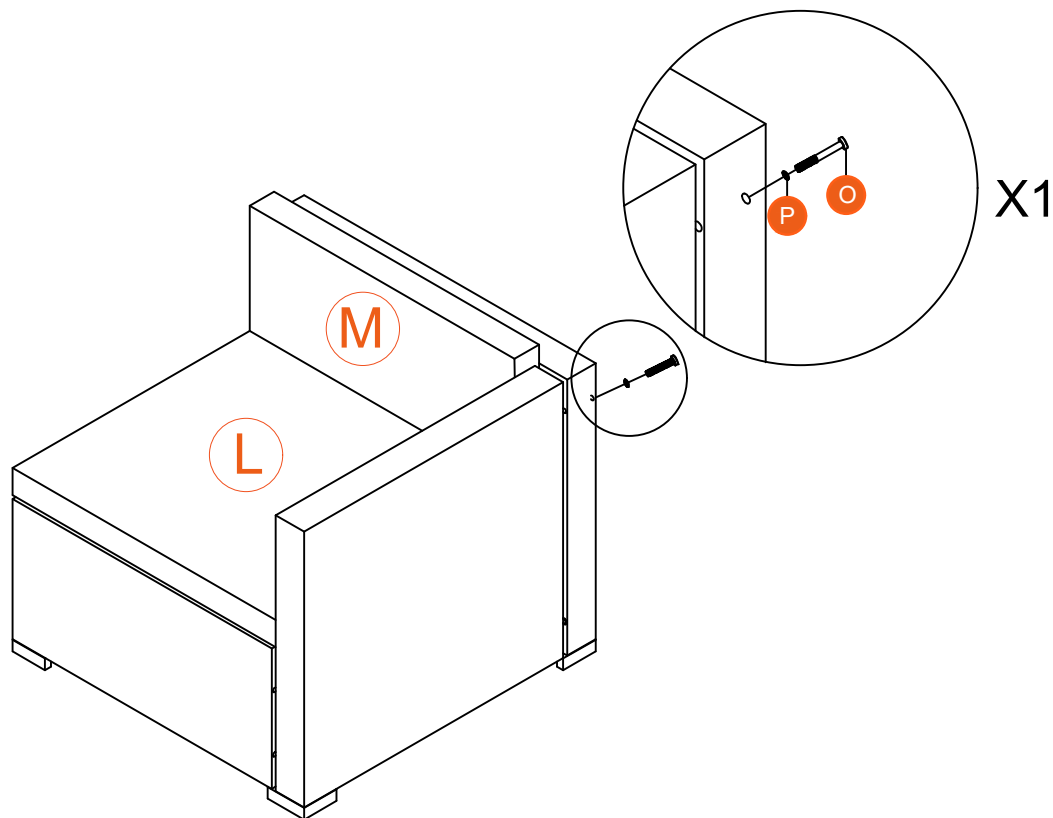
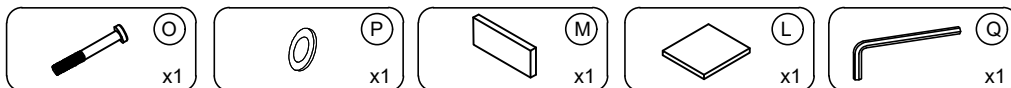

6

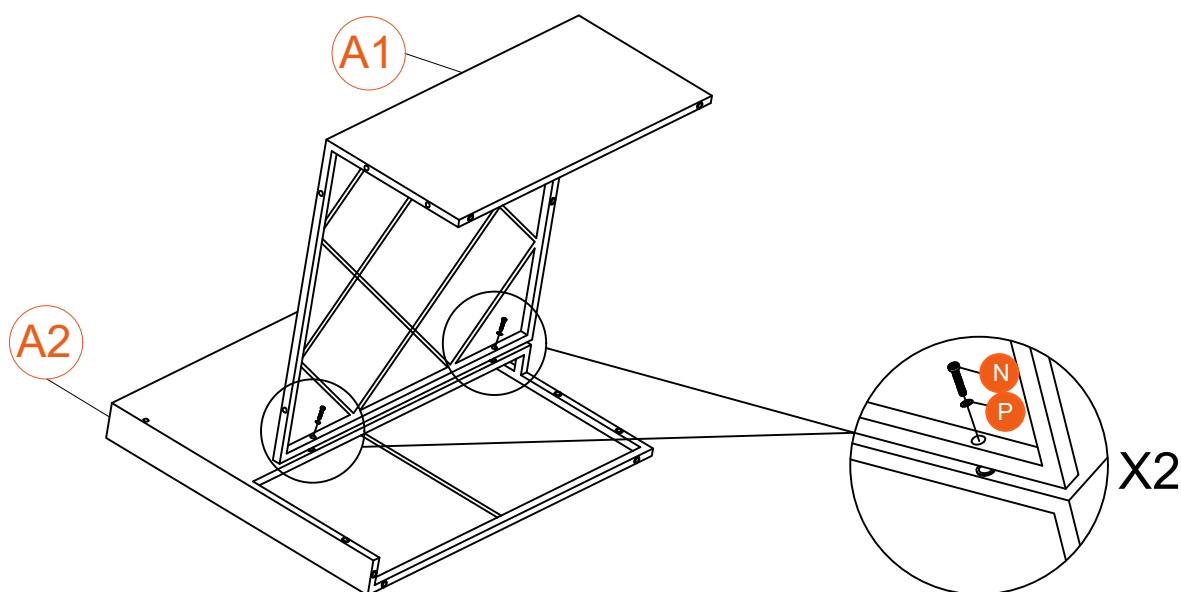

7

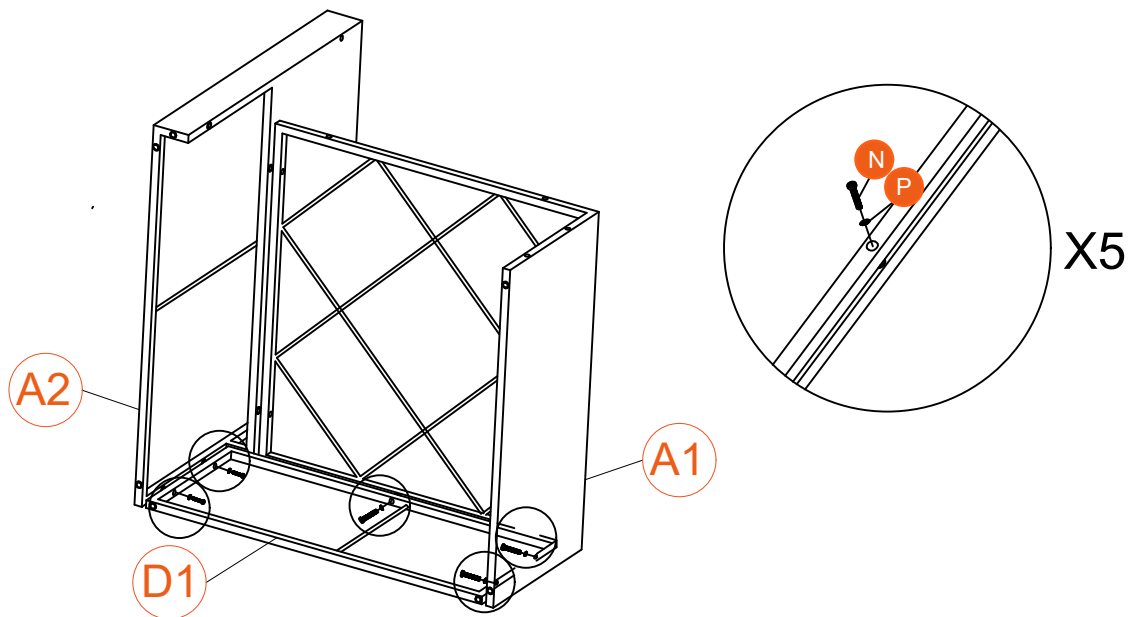
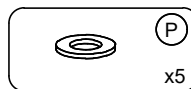
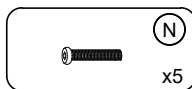
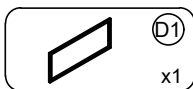

8

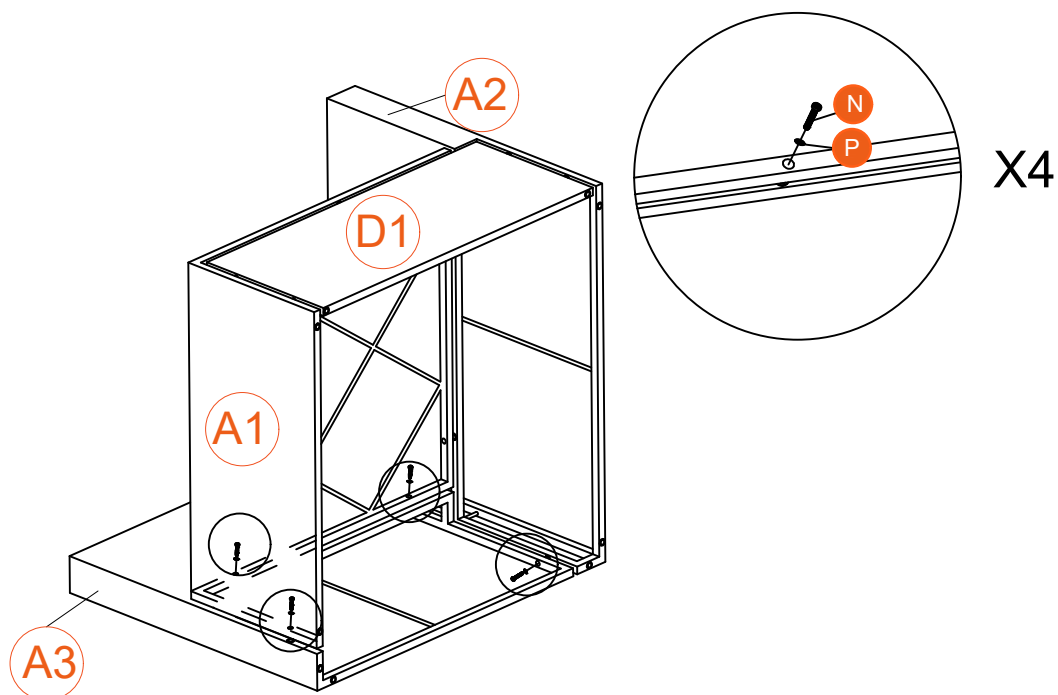
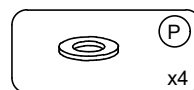
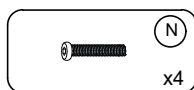
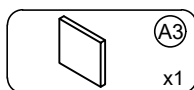

9

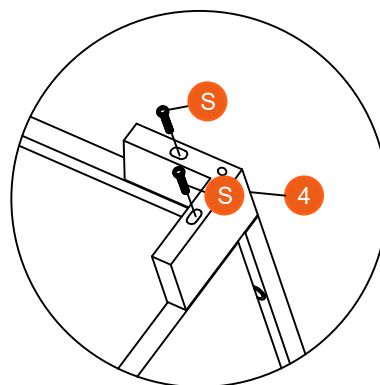
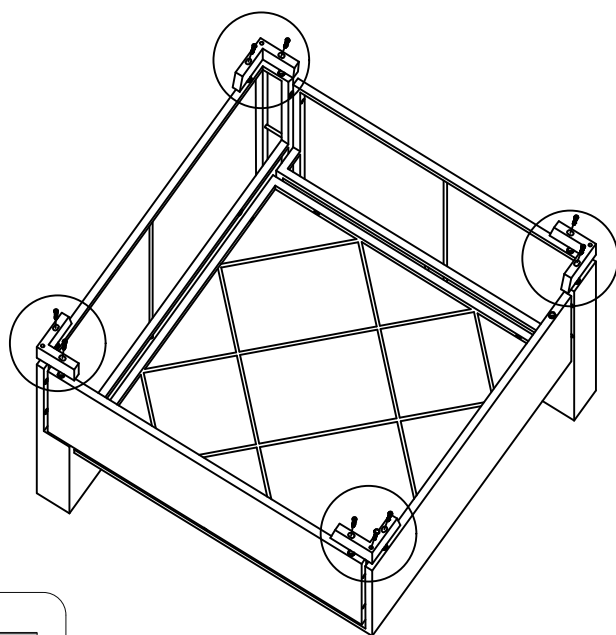
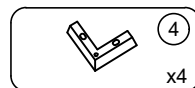

X4

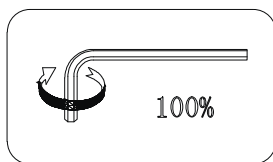

10

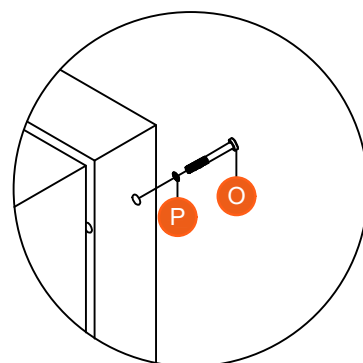
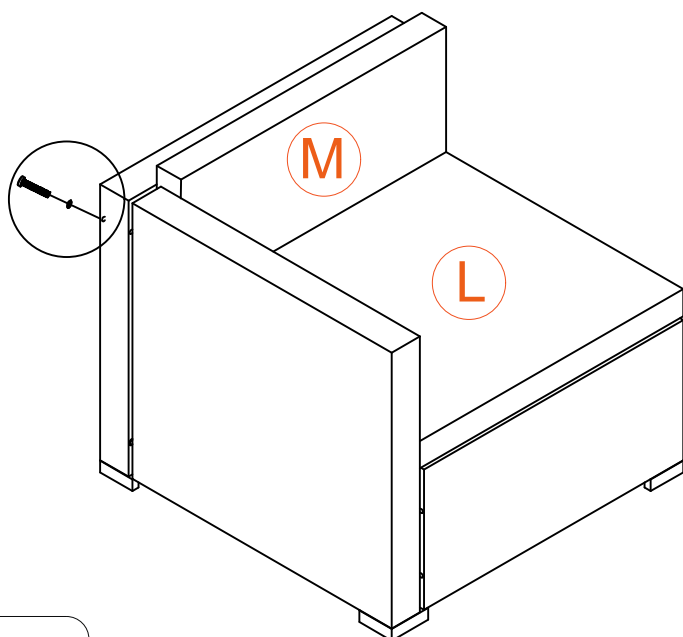
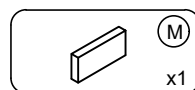
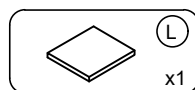
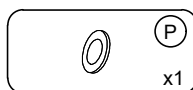

X1

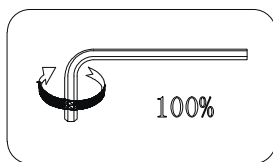

11

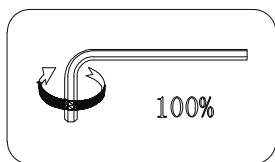
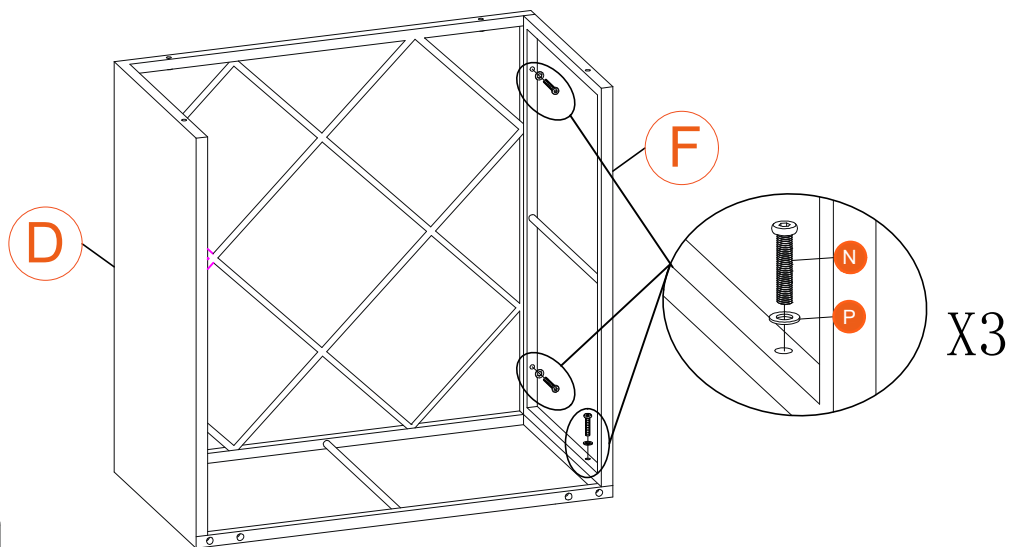
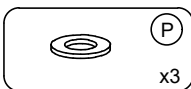
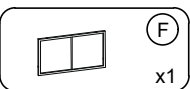
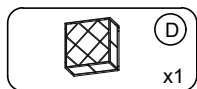

12

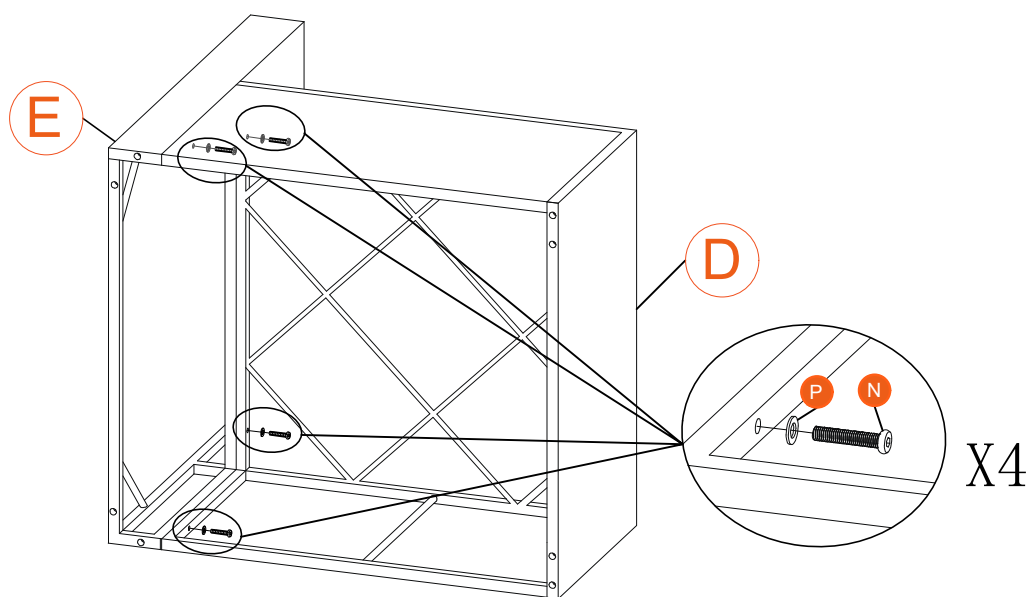
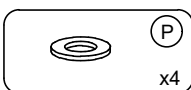
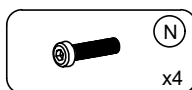
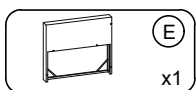

13

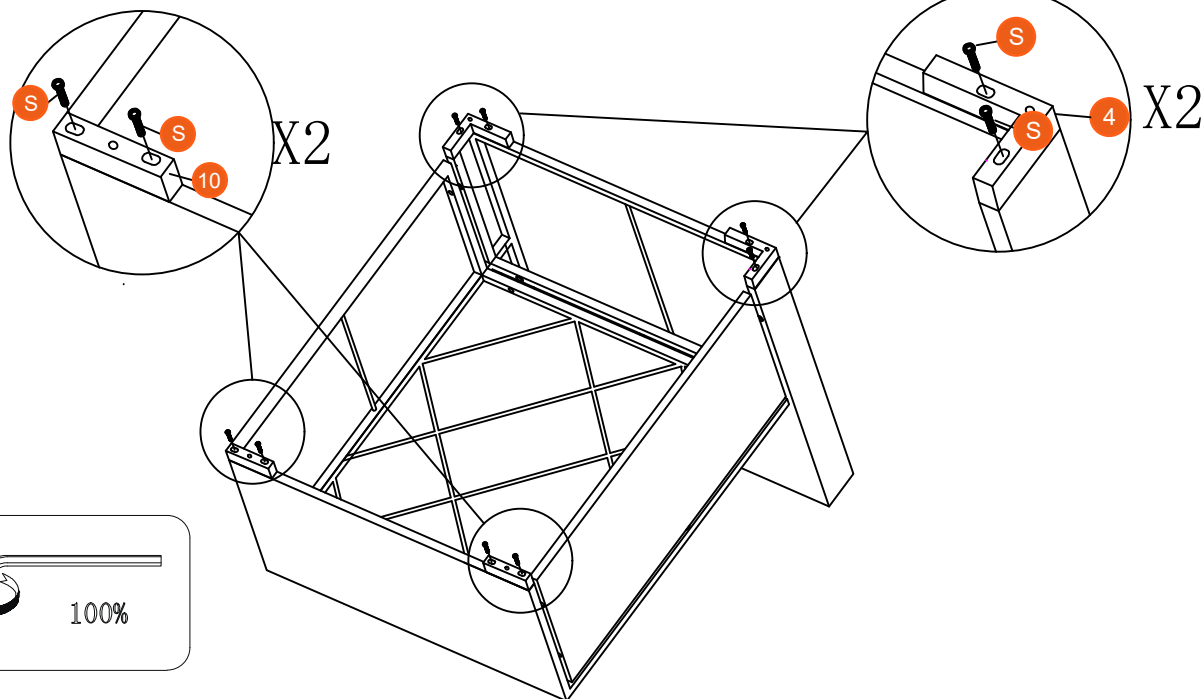
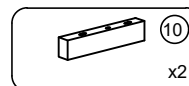
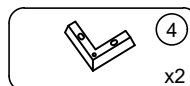

14

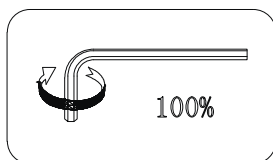
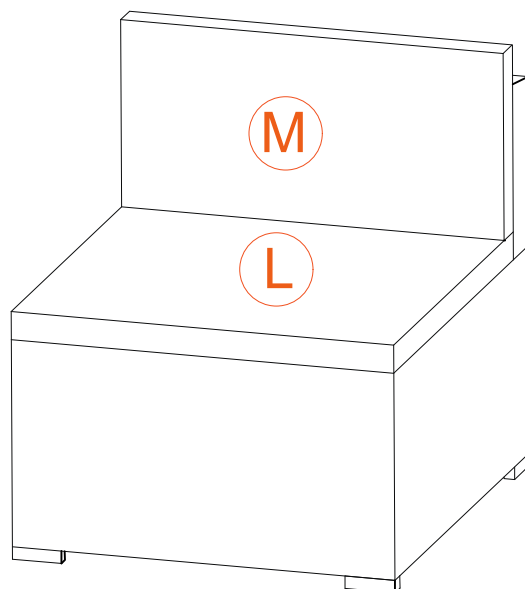
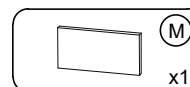
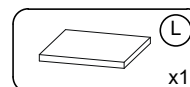

15

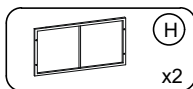

H

x2

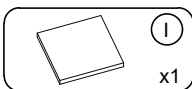

I

x1



N

x4

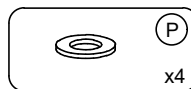

P

x4



Q

x1

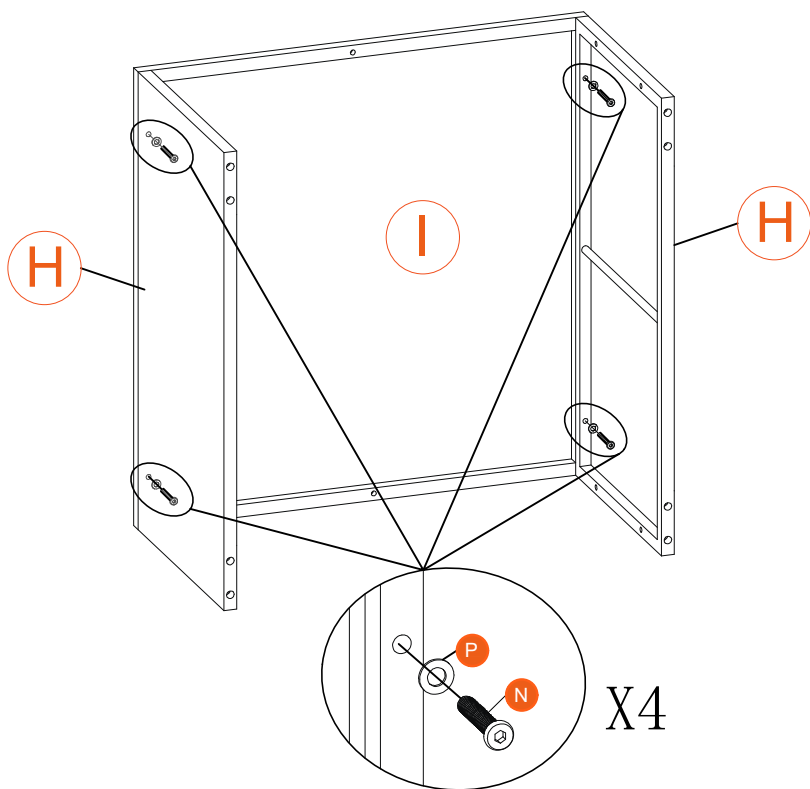

16

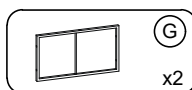

G

x2



N

x10

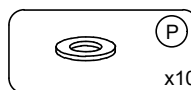

P

x10



Q

x1

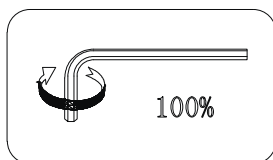
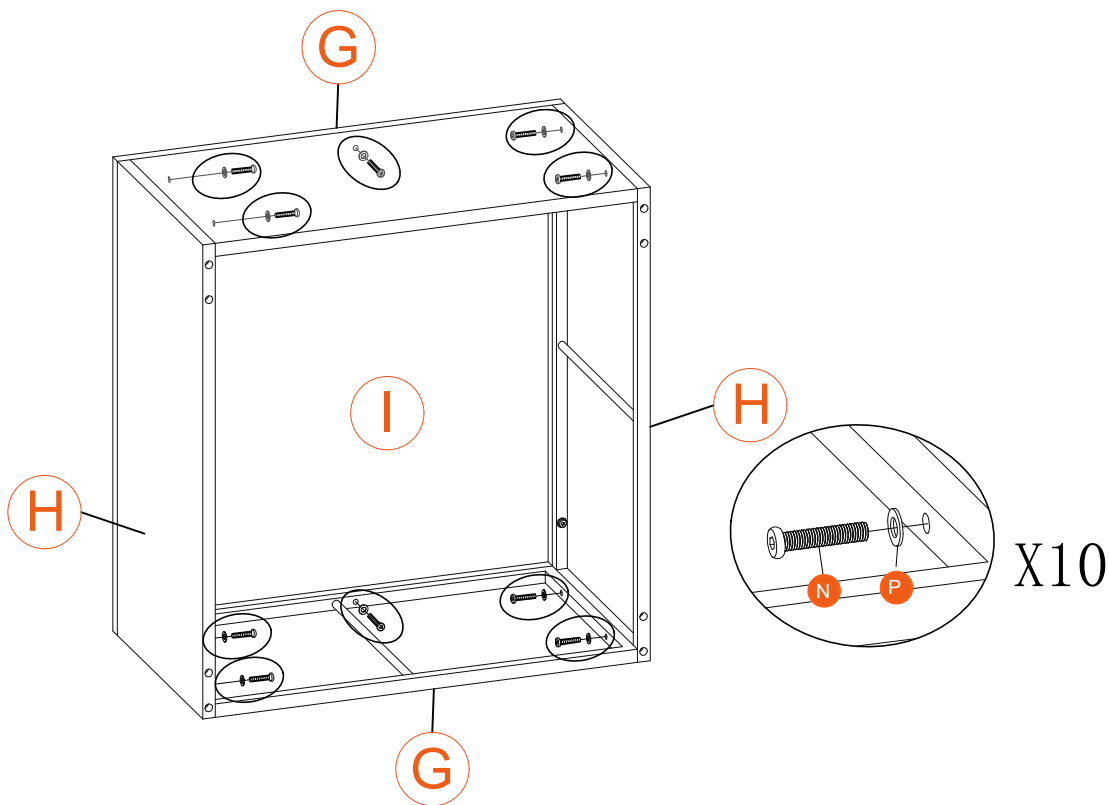

100%

17

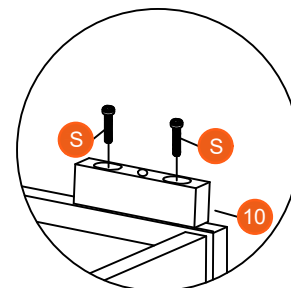
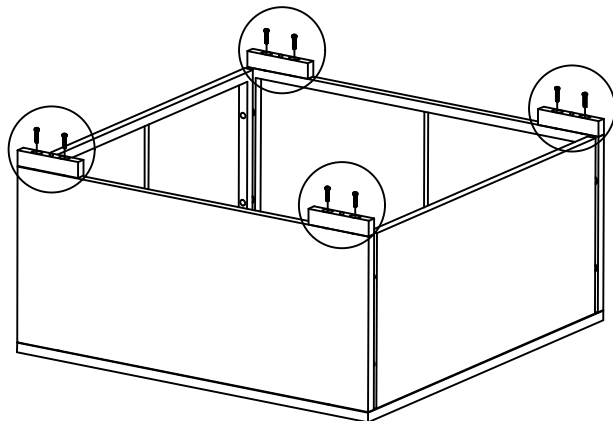
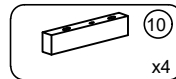

X4

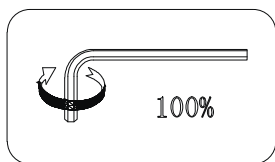

18

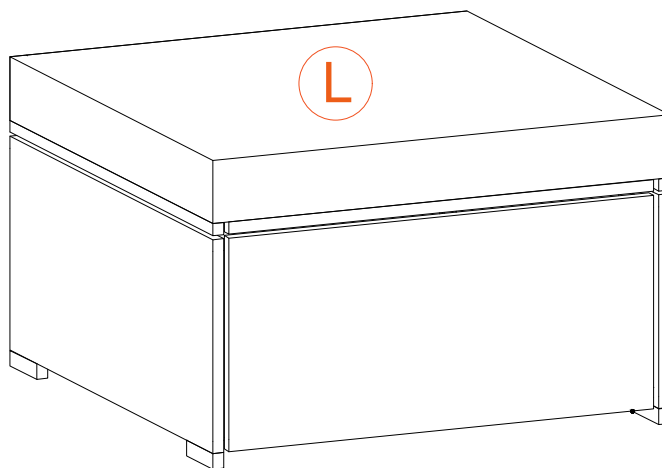

19

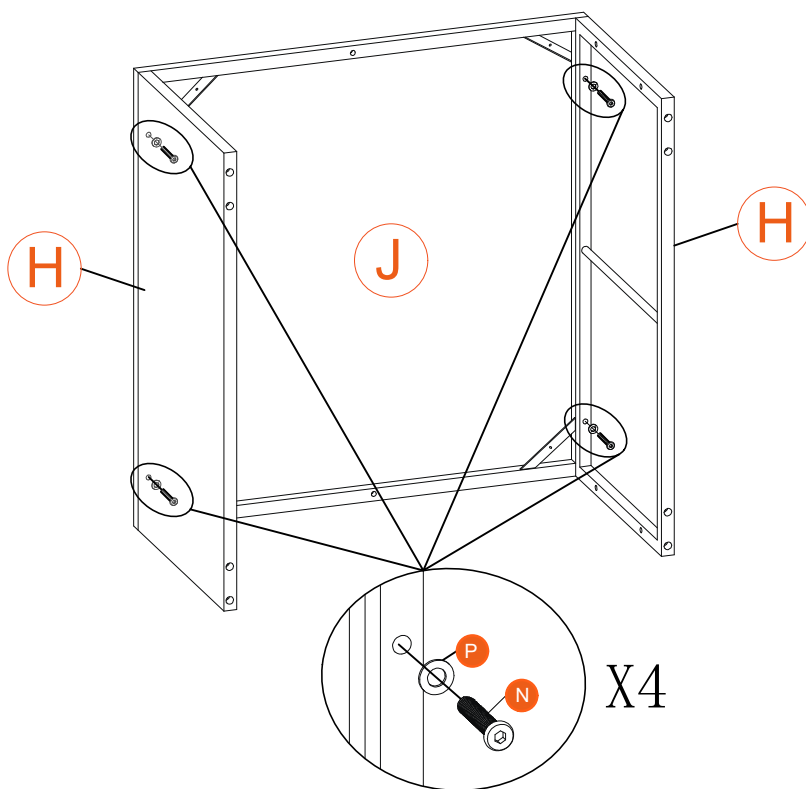

20

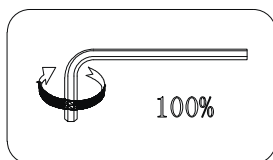
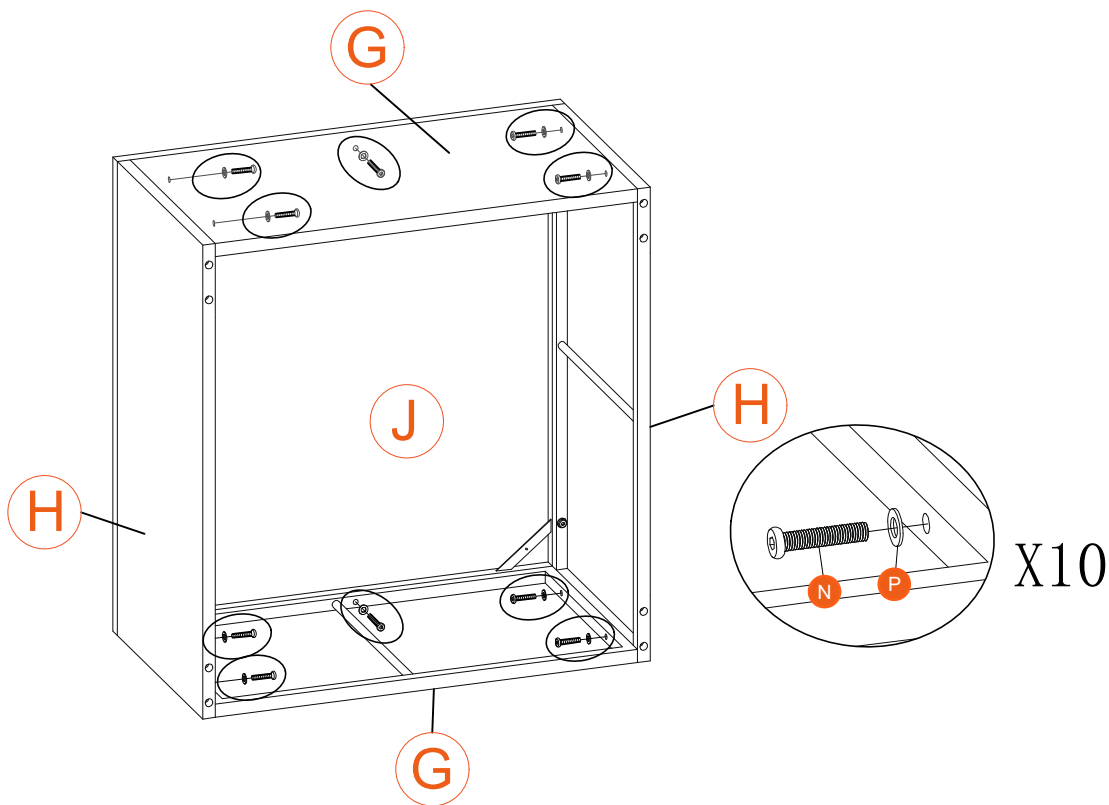
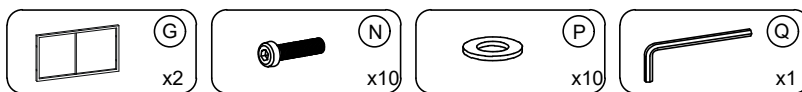

21

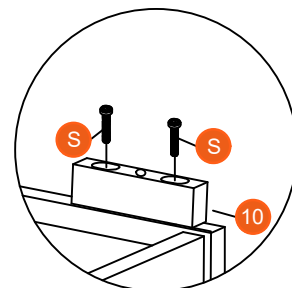
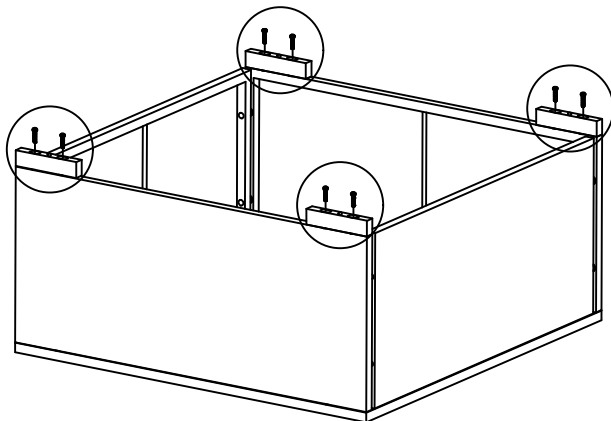
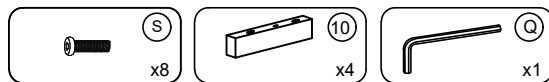

X4

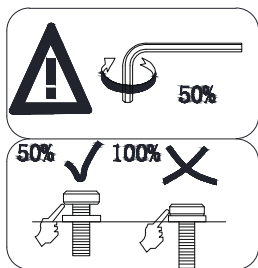

22

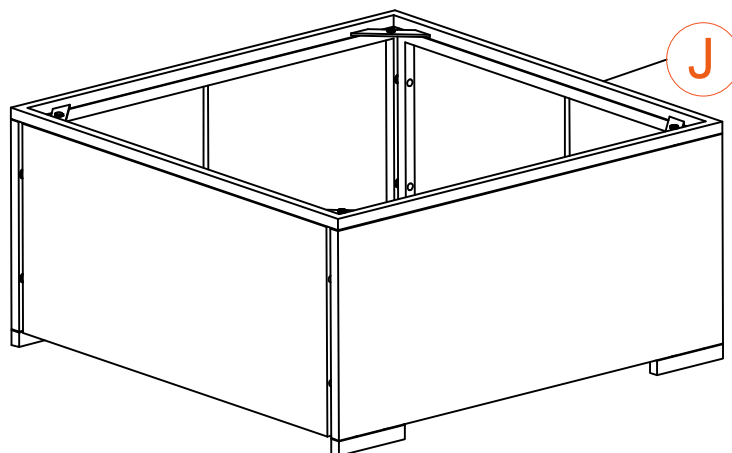
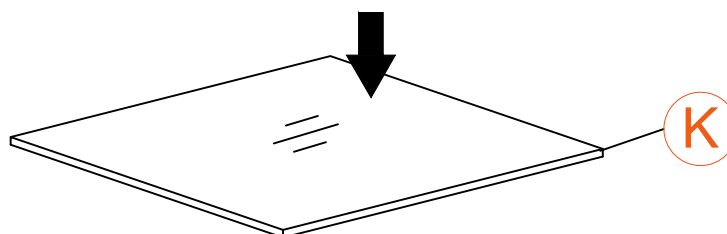
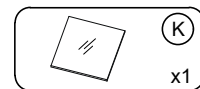

23

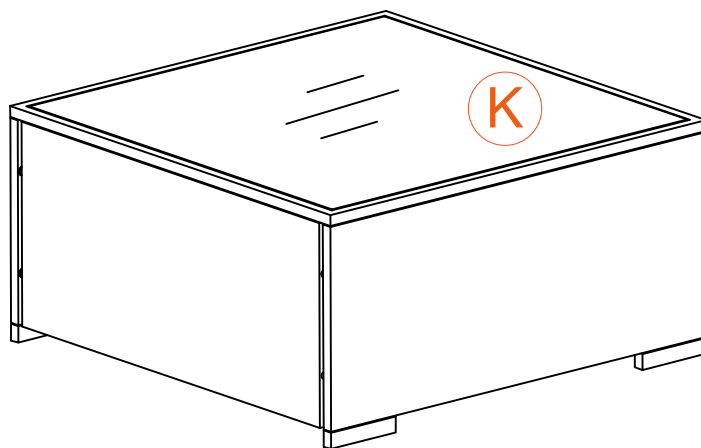

24

