

p

Using Camlocks

Step 1

Connect the male camlock as directed in the assembly instructions using a screwdriver.

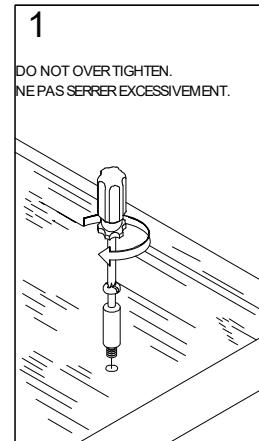

Step 2

Push the male camlock into the entry hole.

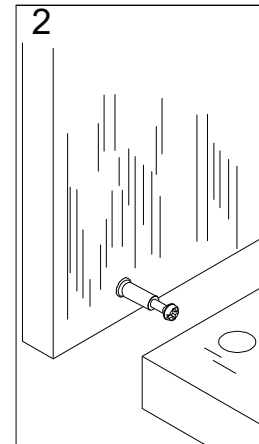

Step 3

Insert the female camlock as shown in the instruction.

Note: ensure that the arrow on the top of the camlock points towards the entry hole for the male camlock.

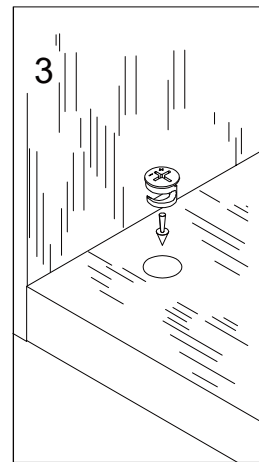

Step 4

Turn the female camlock clockwise with a screwdriver.

You should feel a click when the camlock is locked in place.

The joint is now secure.

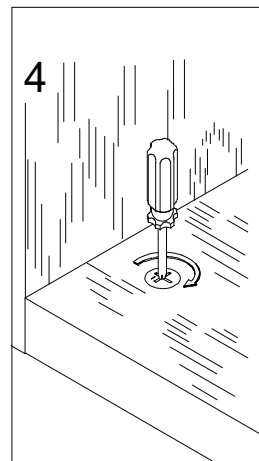

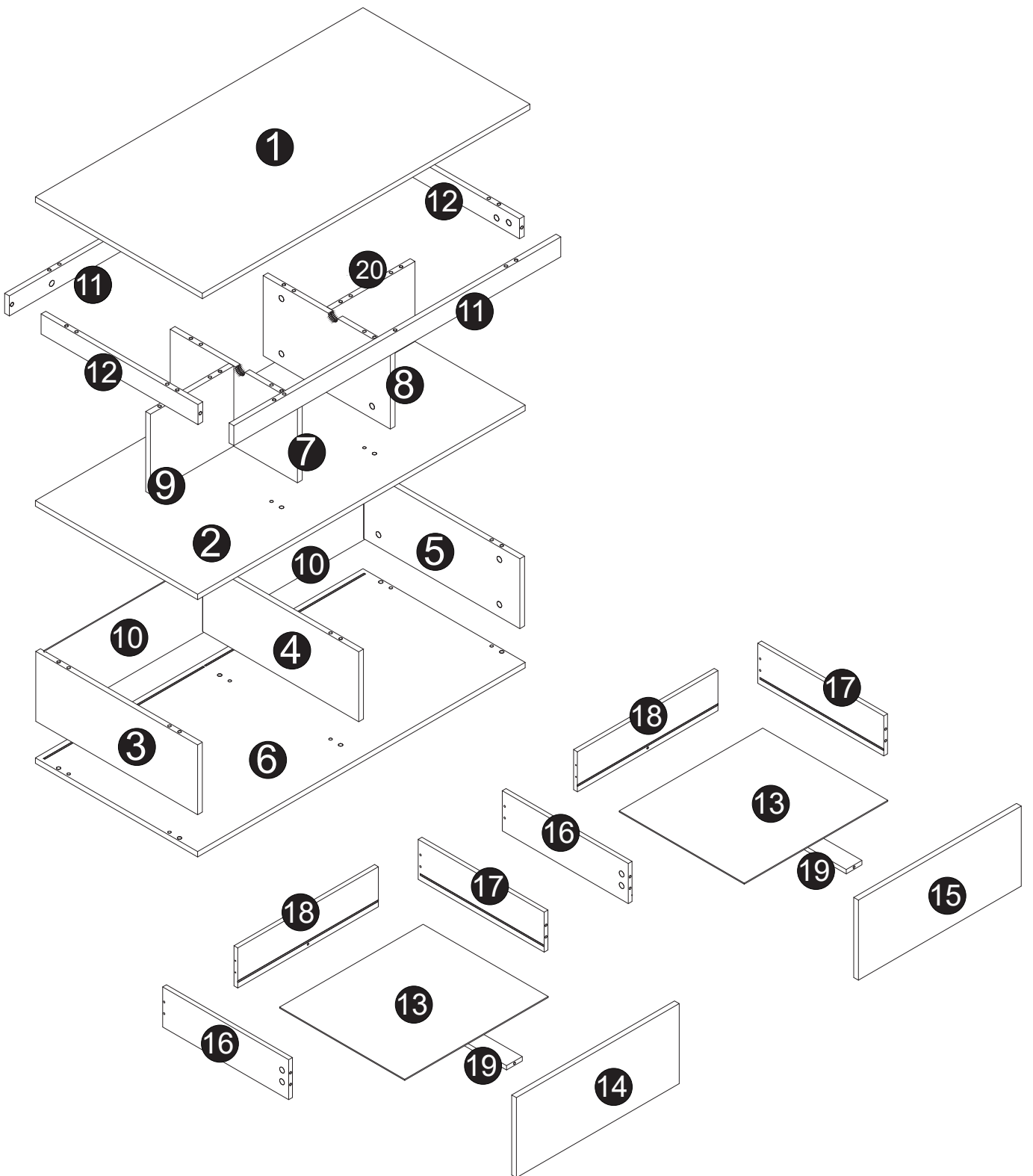

Parts List (EN) / Teile Liste (DE)

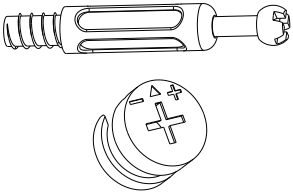
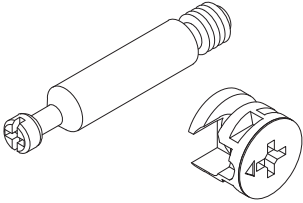
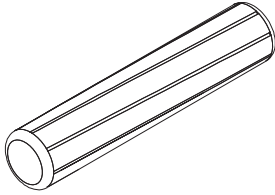
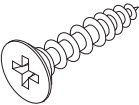
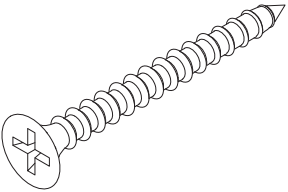
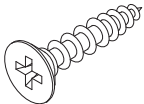
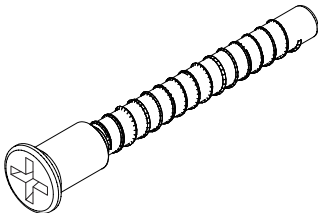
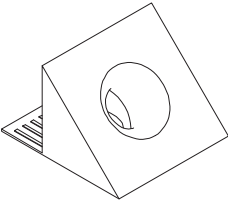
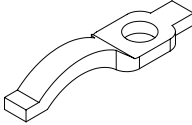
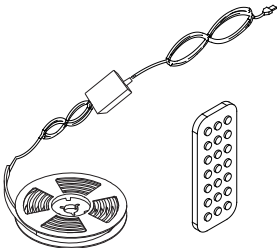
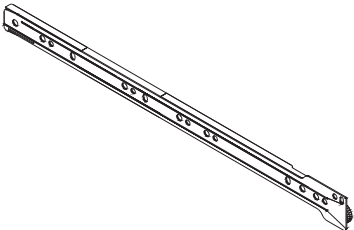
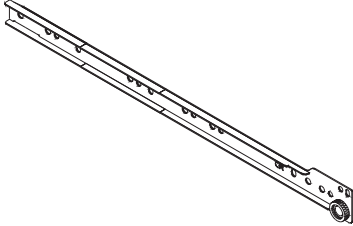
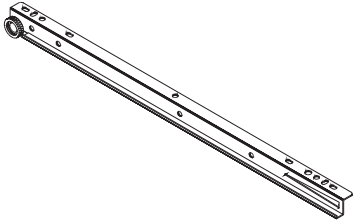
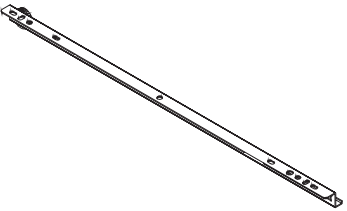
<p>A</p>  <p>38 pcs</p>	<p>B</p>  <p>12 pcs</p>	<p>C</p>  <p>$\Phi 8 \times 40 \text{MM}$ 32 pcs</p>
<p>D</p>  <p>$\Phi 3.5 \times 14 \text{MM}$ 24 pcs</p>	<p>E</p>  <p>$\Phi 3.5 \times 35 \text{MM}$ 8 pcs</p>	<p>F</p>  <p>$\Phi 3 \times 12 \text{MM}$ 8 pcs</p>
<p>G</p>  <p>$\Phi 5 \times 40 \text{MM}$ 4 pcs</p>	<p>H</p>  <p>8 pcs</p>	<p>J</p>  <p>8 pcs</p>
<p>K</p>  <p>1 pc</p>	<p>CL</p>  <p>2 pcs</p>	<p>CR</p>  <p>2 pcs</p>
<p>DR</p>  <p>2 pcs</p>	<p>DL</p>  <p>2 pcs</p>	

Assembly (EN) /Montageschritte (DE)

STEP 1

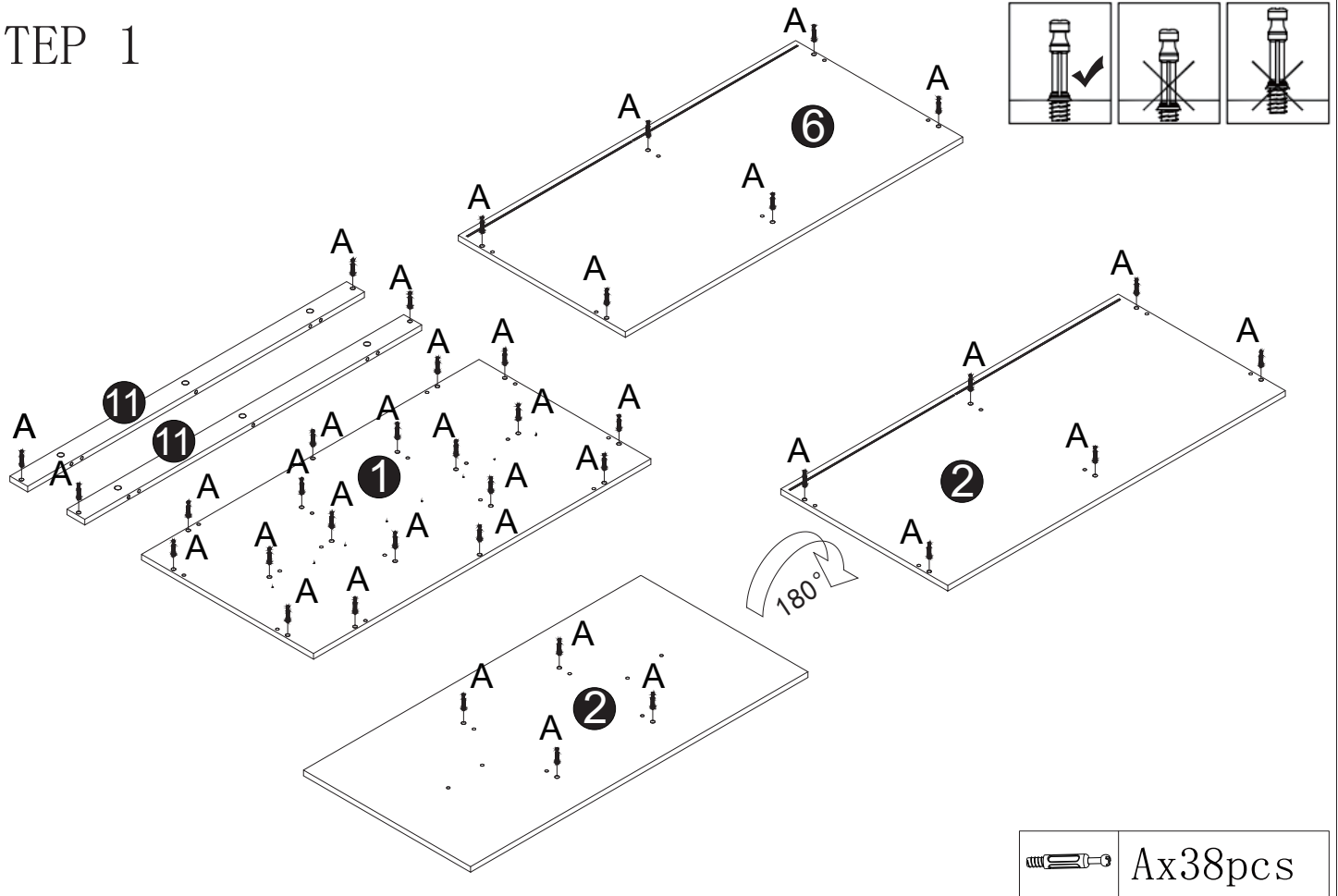

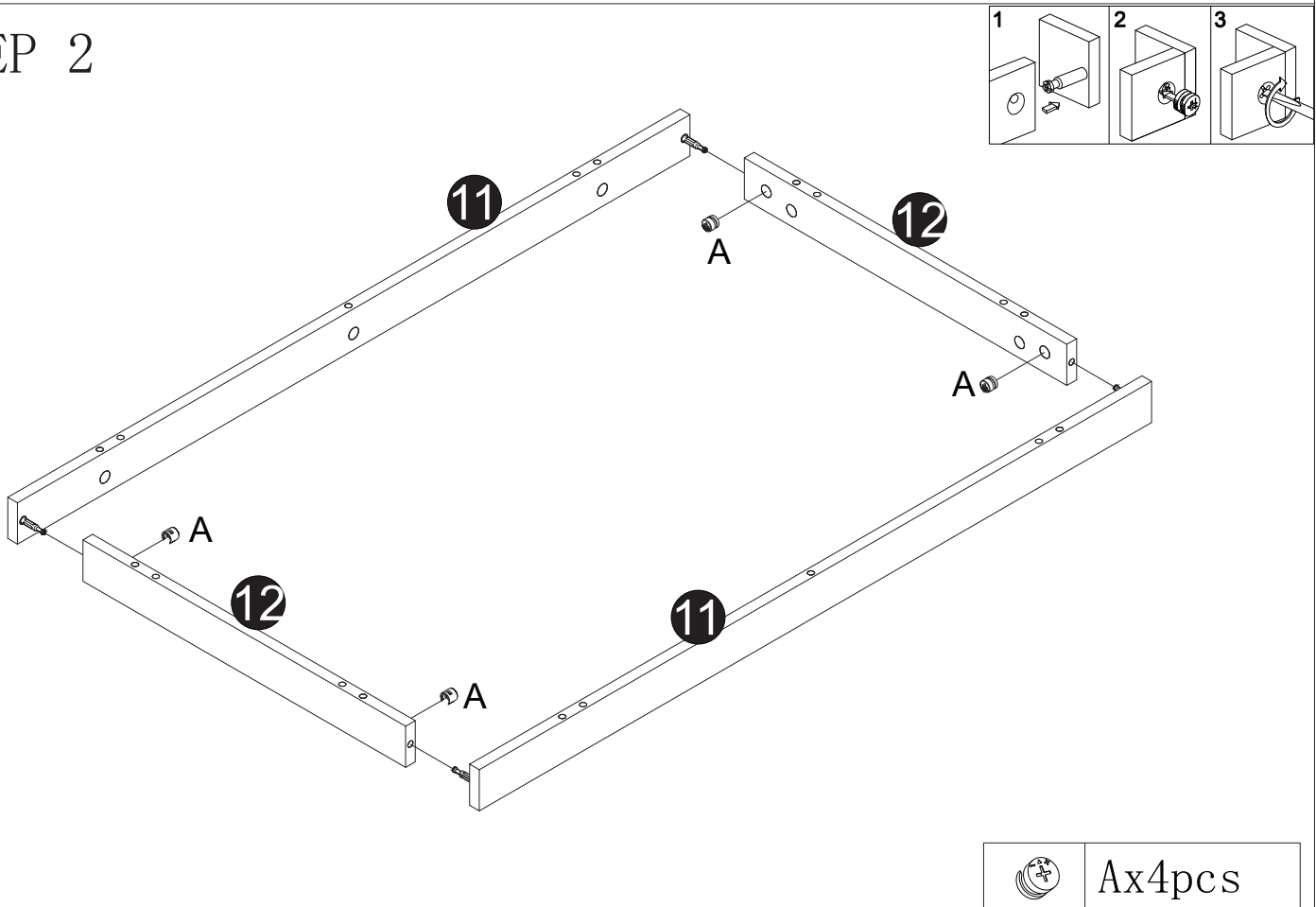

STEP 2



Assembly (EN) /Montageschritte (DE)

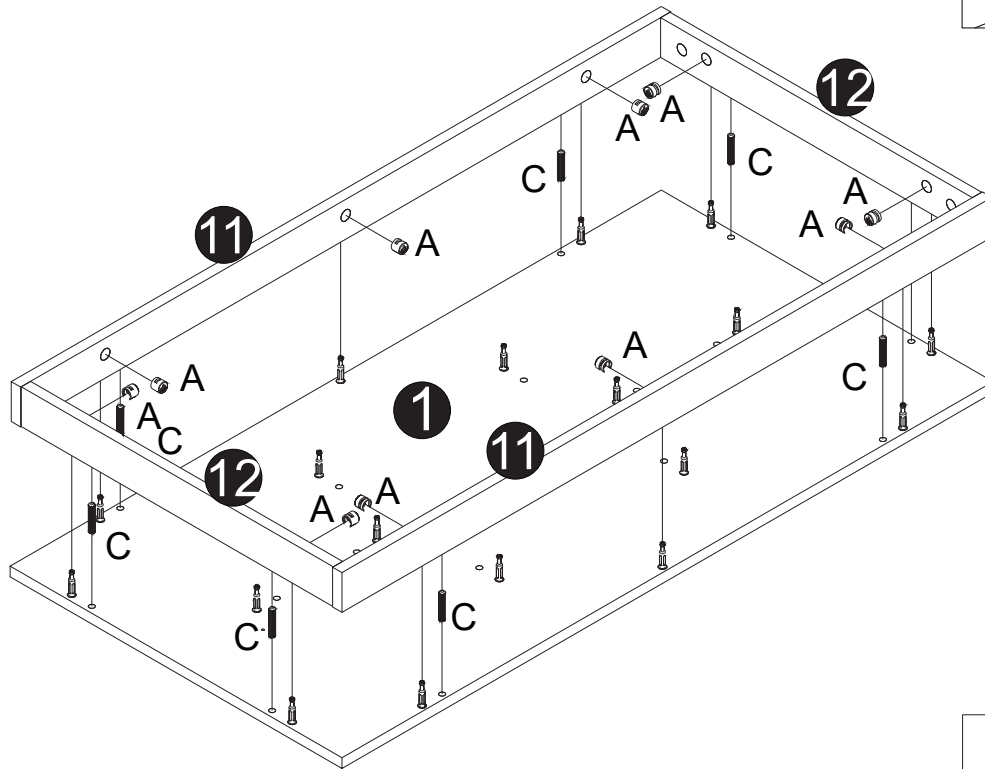
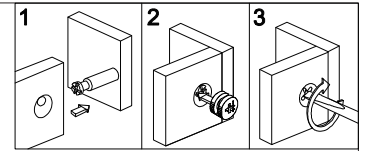

STEP 3

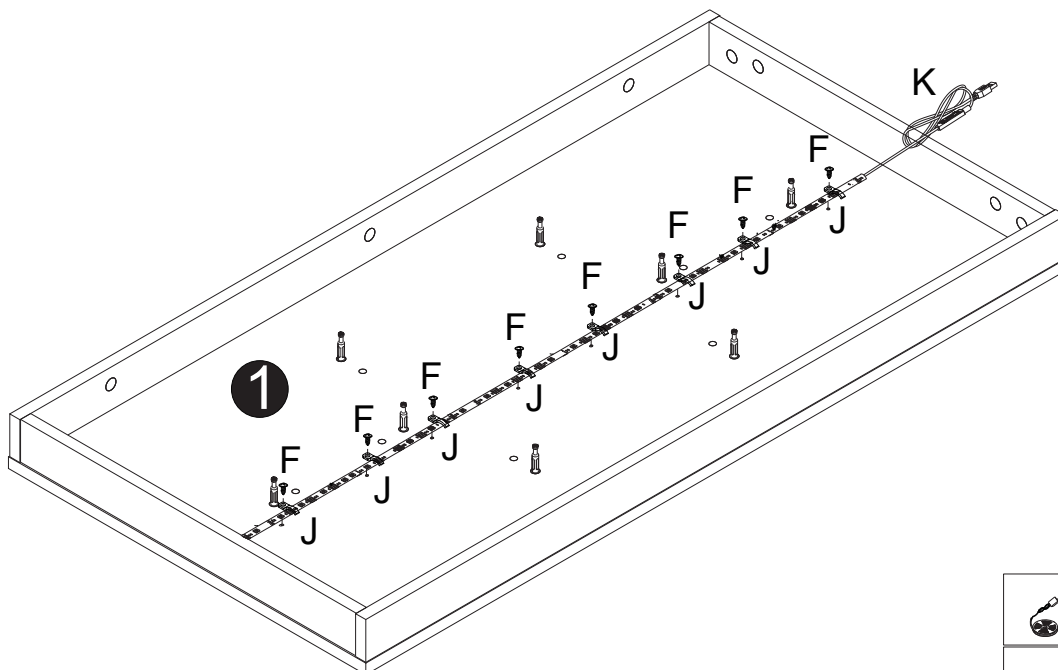

	Ax10pcs
	Cx8pcs

STEP 4





	Kx1pc
	Fx8pcs
	Jx8pcs

Assembly (EN) /Montageschritte (DE)

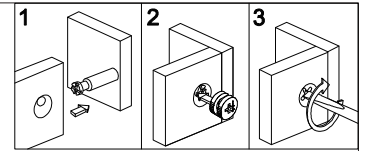
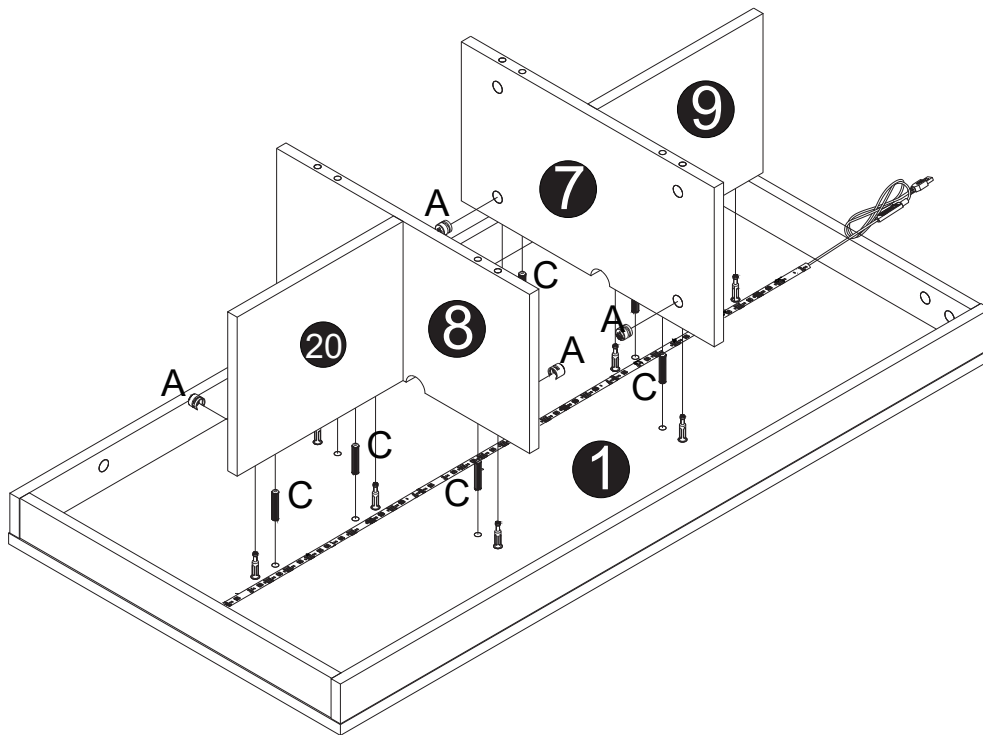

STEP 5

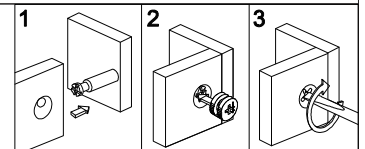
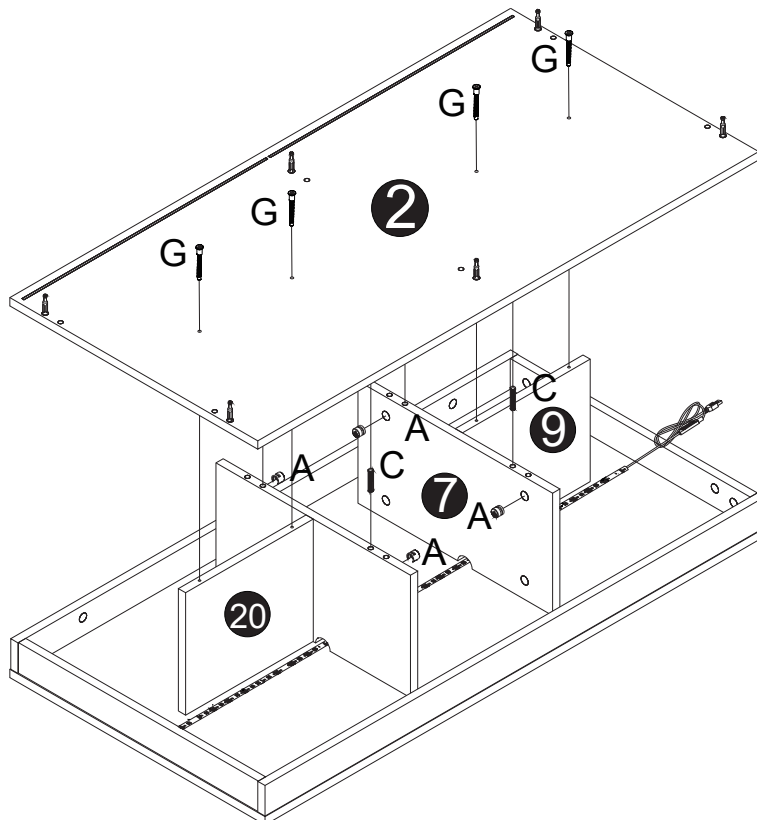

	Ax8pcs
	Cx8pcs

STEP 6





	Cx4pcs
	Ax4pcs
	Gx4pcs

Assembly (EN) /Montageschritte (DE)

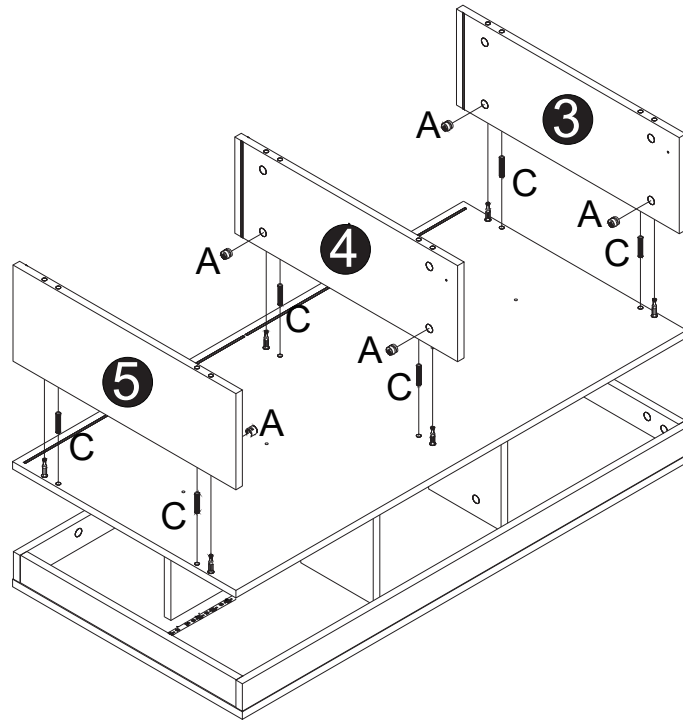
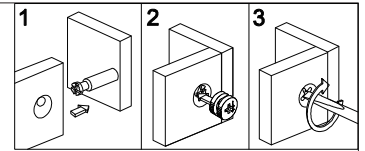
STEP 7



	Ax6pcs
	Cx6pcs

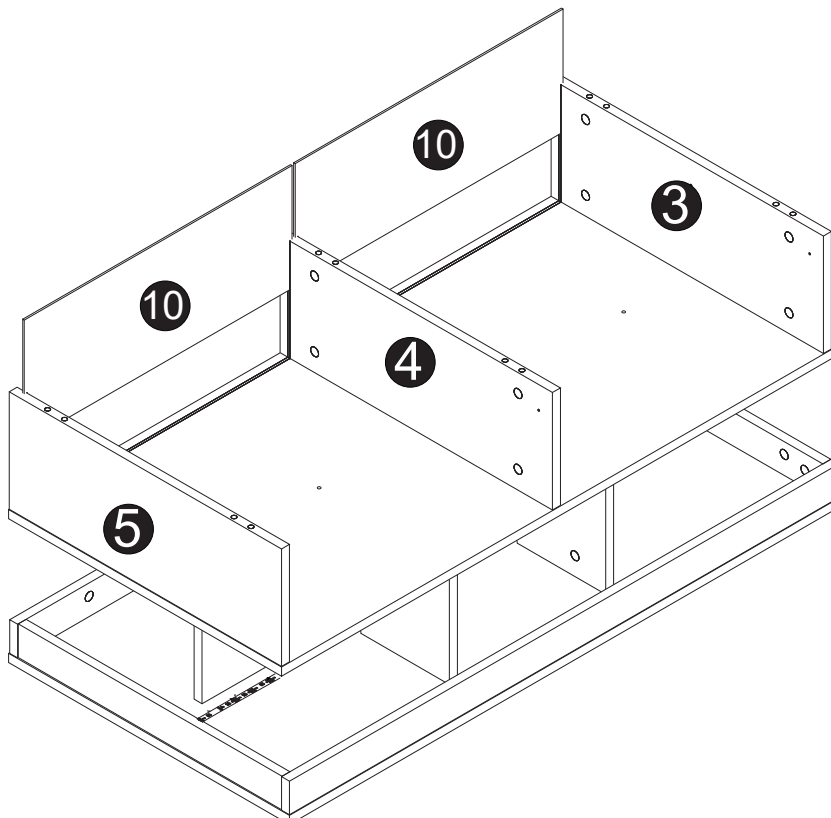

STEP 8



Assembly (EN) /Montageschritte (DE)

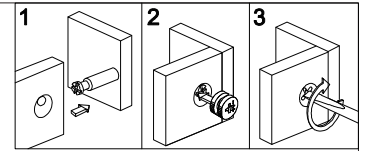
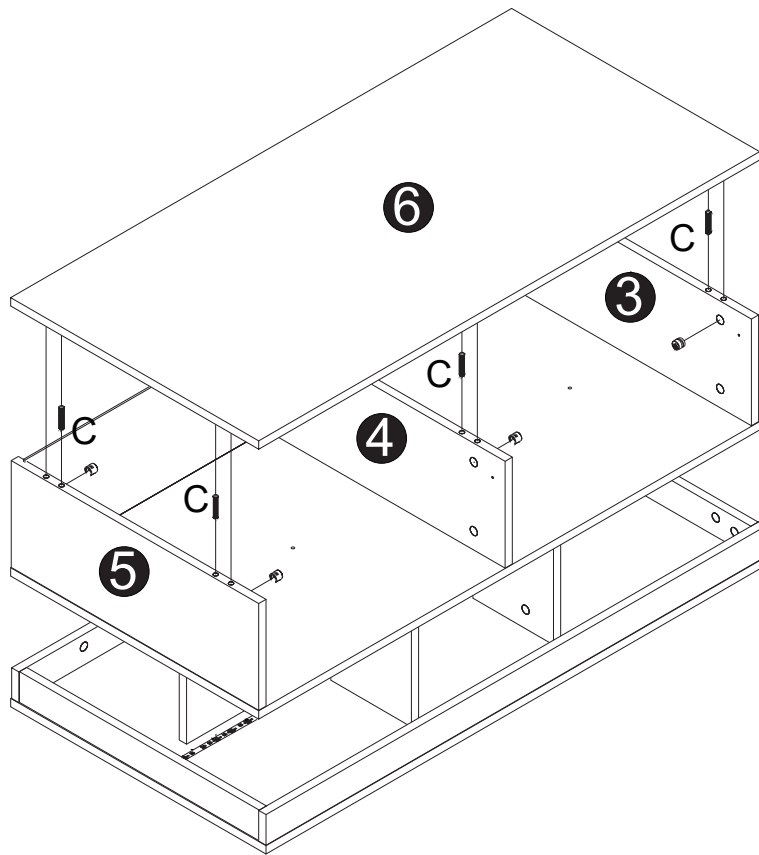

STEP 9

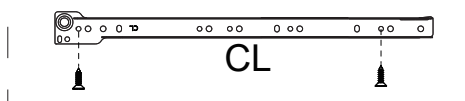
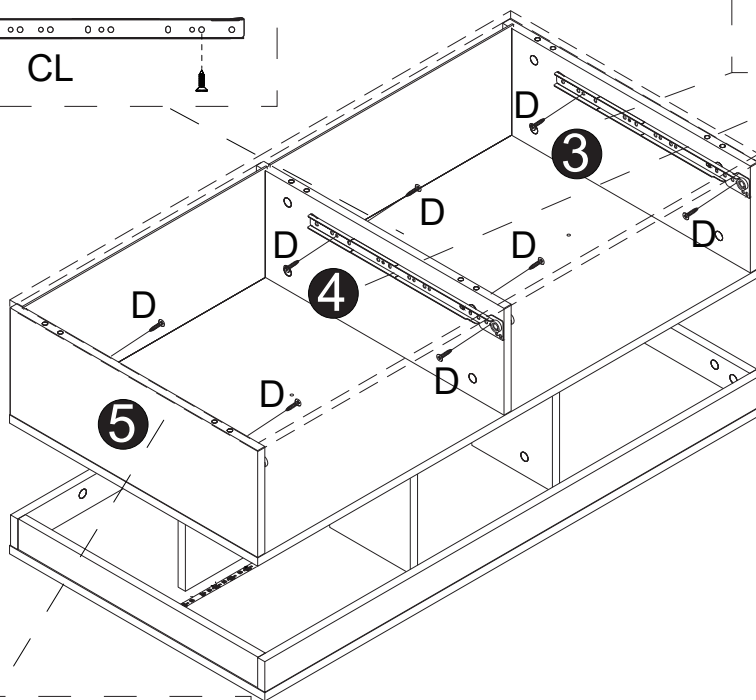
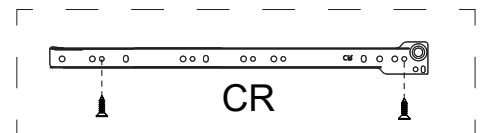
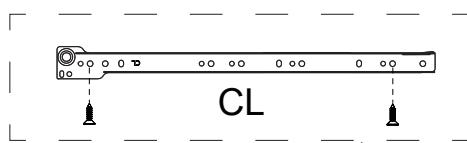

	Bx6pcs
	Cx6pcs

STEP 10



	Dx8pcs
	CLx2pcs
	CRx2pcs

Assembly (EN) /Montageschritte (DE)

STEP 11

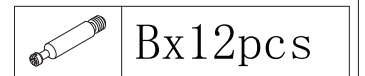
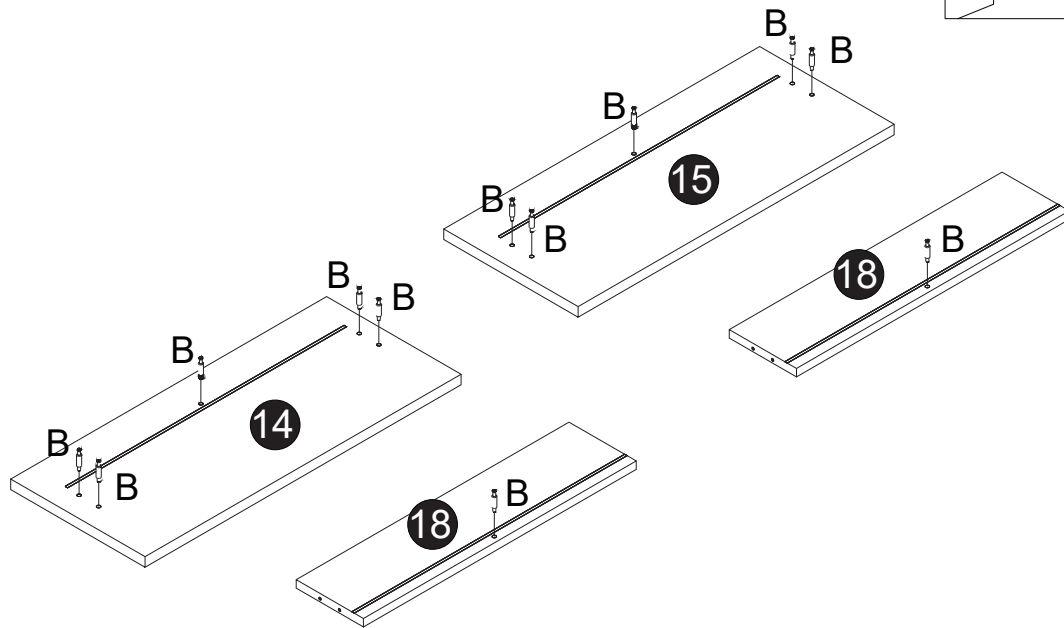
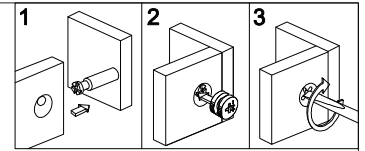

STEP 12

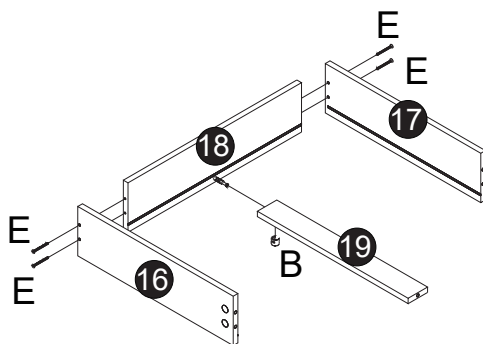
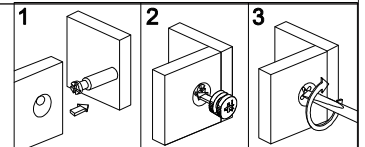

x2

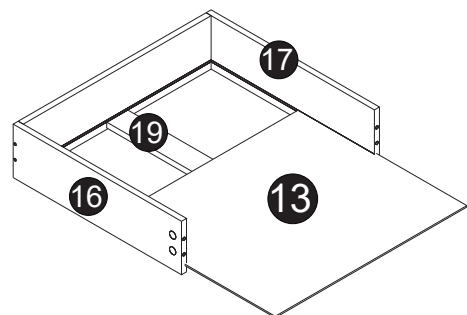

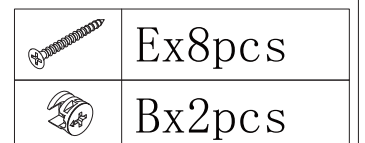

x2



Assembly (EN) /Montageschritte (DE)

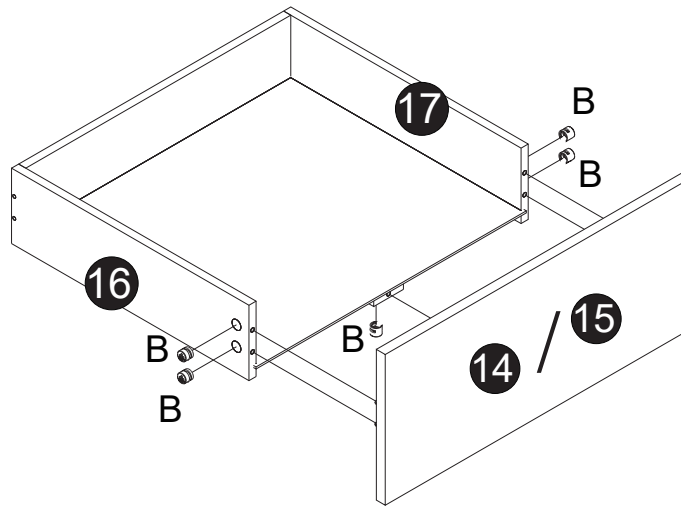
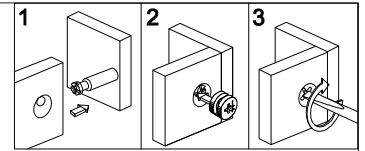

STEP 13

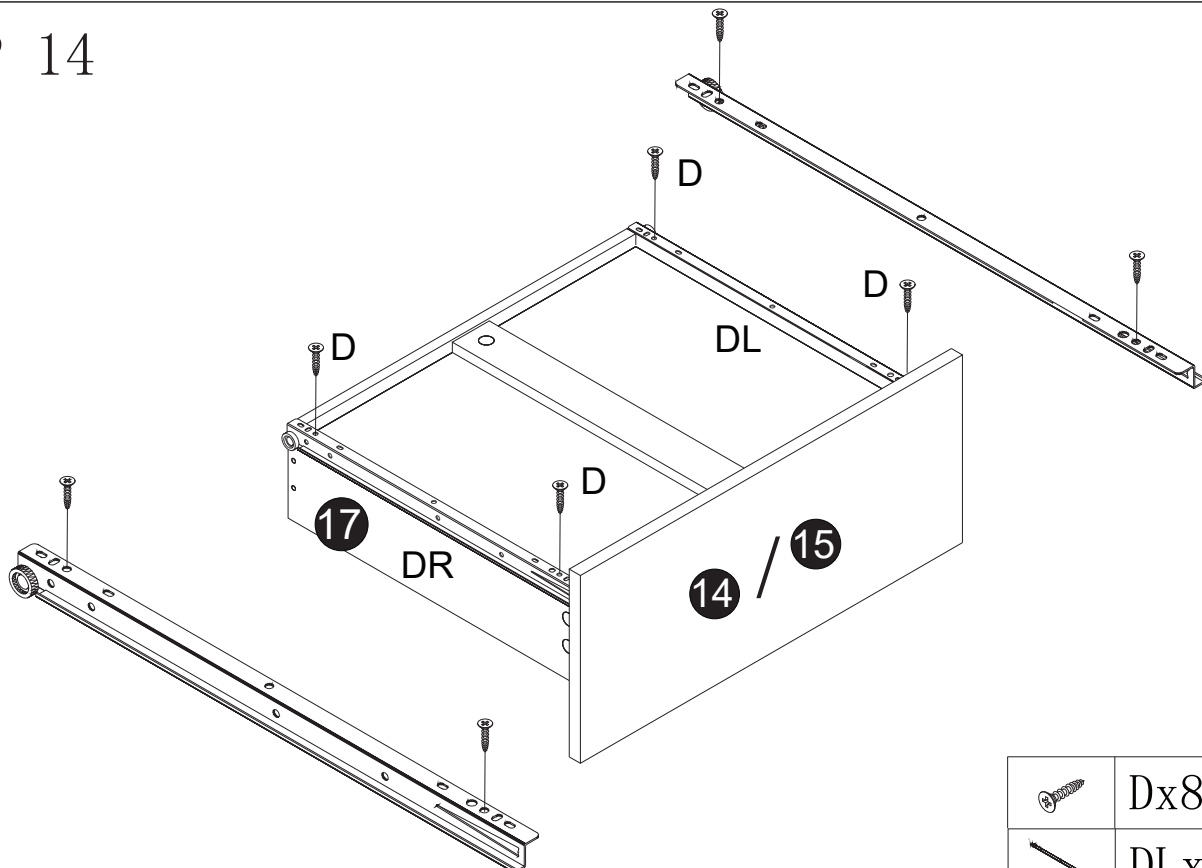

	Bx10pcs
---	---------

STEP 14





	Dx8pcs
	DLx2pcs
	DRx2pcs

Assembly (EN) /Montageschritte (DE)

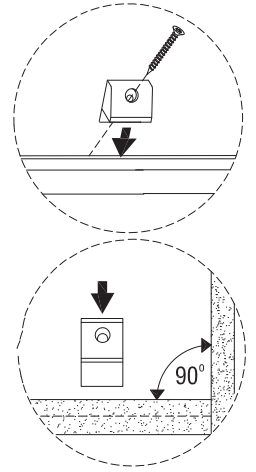
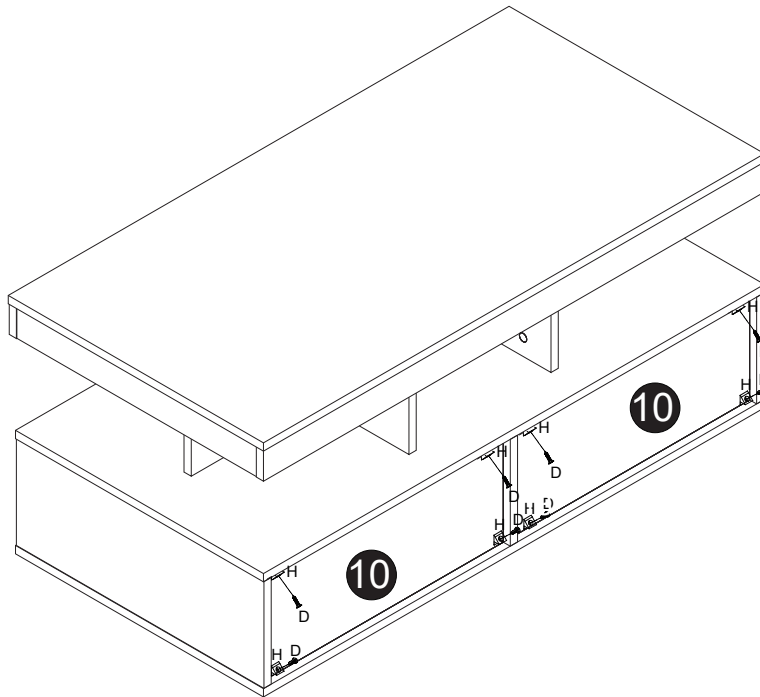
STEP 15



	Dx8pcs
	Hx8pcs

STEP 16

