

Product Installation Manual



GX-PB-0001 / GX-PB-0002

If you have any questions, please feel free to contact us.
Email: customerservice@seedayhome.com

NOTICE

Read through the instructions before installing the product. Suggested assembly for multiple people.

Give yourself enough room for the assembly process and follow the instructions to assemble the items correctly.

CAUTION If you use an electric screwdriver to tighten screws, be careful to slow down and stop when the screws are tightened. Failure to do so may result in stripping of the screws.

Before installation, sort all parts and check that the accessories are in good condition.

If the installation kit is equipped with anti-tip device, it is recommended to secure the cabinet to the wall with screws after installation to prevent it from falling down.

The remaining parts are spares that can be kept for future replacement if needed.

SAFETY INFORMATION

The accessory bag contains some small accessories , which should be kept away from children.

Kids are not allowed to climb or play with the product for safety reasons.

HINWEIS

Lesen Sie vor der Montage des Produkts die Anleitung durch. Empfohlene Montage für mehrere Personen.

Geben Sie sich genügend Platz für den Montageprozess und folgen Sie den Anweisungen, um die Artikel richtig zusammenzubauen.

VORSICHT Wenn Sie zum Anziehen von Schrauben einen elektrischen Schraubendreher verwenden, achten Sie darauf, dass Sie langsamer fahren und anhalten, wenn die Schrauben angezogen sind. Andernfalls kann es zum Abisolieren der Schrauben kommen.

Vor der Installation sortieren Sie alle Teile und überprüfen Sie, ob das Zubehör in gutem Zustand ist.

Wenn der Einbausatz mit einer Kippsicherung ausgestattet ist, wird empfohlen, den Schrank nach der Installation mit Schrauben an der Wand zu befestigen, damit er nicht herunterfallen kann.

Die restlichen Teile sind Ersatzteile, die bei Bedarf für künftigen Austausch aufbewahrt werden können.

SICHERHEITSINFORMATIONEN

Die Zubehörtasche enthält einige kleine Accessoires, die von Kindern ferngehalten werden sollten.

Kinder dürfen aus Sicherheitsgründen nicht klettern oder mit dem Produkt spielen.

AVVISO

Leggere attentamente le istruzioni prima di installare il prodotto. Montaggio consigliato per più persone.

Concediti spazio sufficiente per il processo di assemblaggio e segui le istruzioni per assemblare correttamente gli elementi.

ATTENZIONE Se si utilizza un cacciavite elettrico per serrare le viti, fare attenzione a rallentare e fermarsi quando le viti sono serrate. In caso contrario, le viti possono essere rimosse.

Prima dell'installazione, ordinare tutte le parti e verificare che gli accessori siano in buone condizioni.

Se il kit di installazione è dotato di dispositivo antiribaltamento, si raccomanda di fissare il mobile alla parete con delle viti dopo l'installazione per evitare che cada.

Le restanti parti sono pezzi di ricambio che possono essere conservati per la sostituzione futura, se necessario.

INFORMAZIONI SULLA SICUREZZA

La borsa accessorio contiene alcuni piccoli accessori, che dovrebbero essere tenuti lontano dai bambini.

I bambini non possono arrampicarsi o giocare con il prodotto per motivi di sicurezza.

Notifications

Lisez les instructions avant d'installer le produit. Assemblage suggéré pour plusieurs personnes.

Donnez - vous suffisamment d'espace pour l'assemblage et suivez les instructions pour assembler correctement les articles.

Attention si vous utilisez un tournevis électrique pour serrer les vis, faites attention à ralentir et à vous arrêter lorsque vous serrez les vis. Sinon, il peut provoquer la chute des vis.

Avant l'installation, toutes les pièces sont triées et les accessoires sont vérifiés en bon état.

Si le kit de montage est équipé d'un dispositif anti-basculement, il est recommandé de fixer l'armoire au mur avec des vis après l'installation pour éviter qu'elle ne tombe.

Les pièces restantes sont des pièces de rechange qui peuvent être conservées pour un remplacement futur si nécessaire.

Informations de sécurité

Accessoires le sac contient de petits accessoires qui doivent être tenus à l'écart des enfants.

Pour des raisons de sécurité, les enfants ne doivent pas grimper ou jouer avec le produit.

Aviso

Lea atentamente las instrucciones antes de instalar el producto. Montaje sugerido para varias personas.

Deje suficiente espacio para ensamblar y siga las instrucciones para ensamblar correctamente los artículos.

Cuidado si aprieta el tornillo con un destornillador eléctrico, preste atención a reducir la velocidad y detenerse al apretar el tornillo. De lo contrario, puede causar que los tornillos se caigan.

Antes de la instalación, clasifique todas las piezas y verifique si los accesorios están intactos.

Si el kit de instalación está equipado con un dispositivo antivuelco, se recomienda fijar el armario a la pared con tornillos después de la instalación para evitar que se caiga.









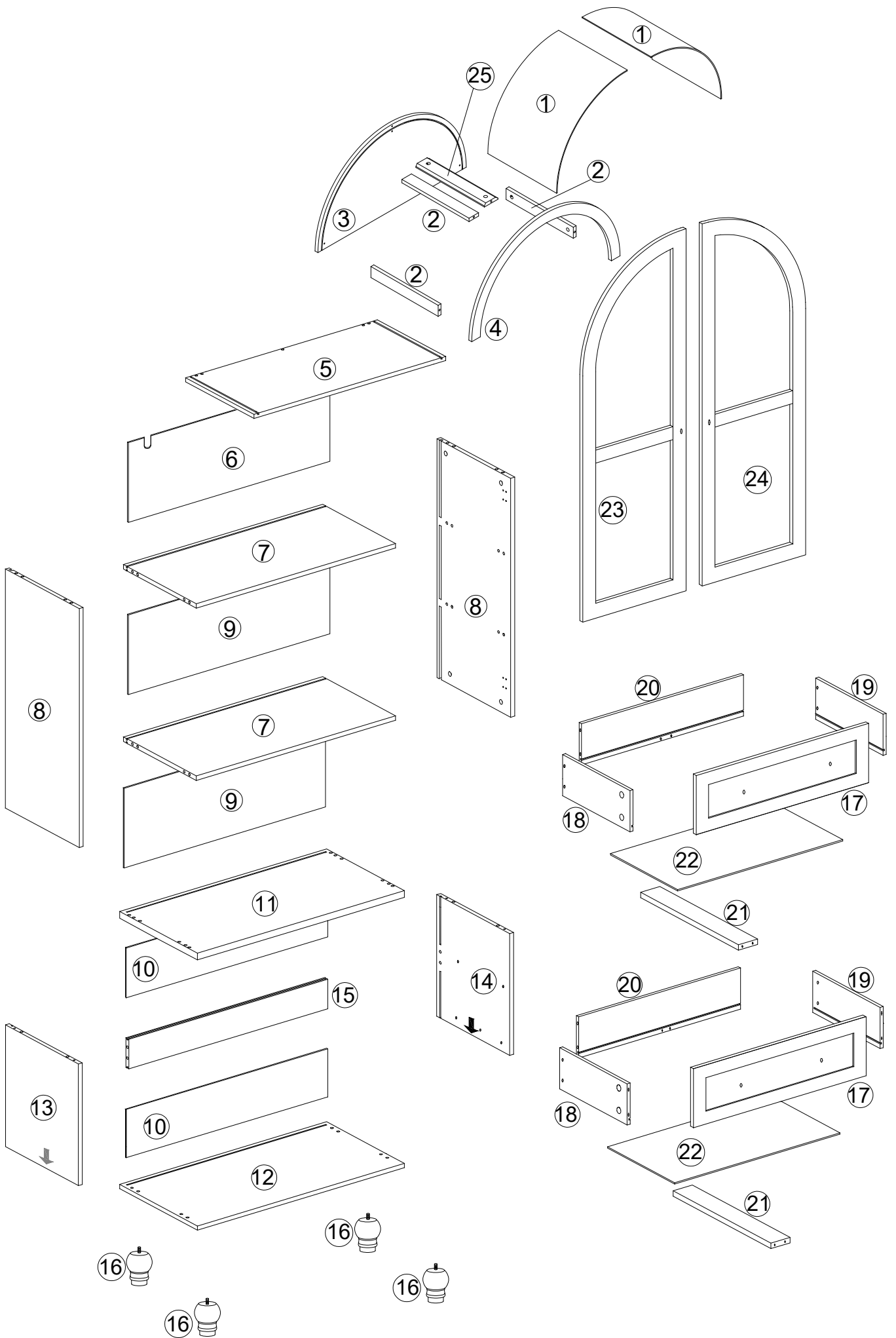



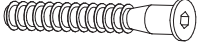

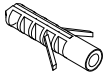

El resto de las piezas son piezas de repuesto y, si es necesario, se pueden conservar para su reemplazo futuro.

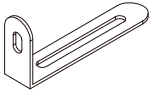
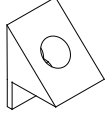
Información de Seguridad

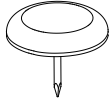
Hay algunos pequeños accesorios en el paquete de accesorios que deben mantenerse alejados de los niños.

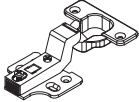
Por razones de seguridad, los niños no pueden escalar ni jugar con el producto.

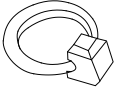

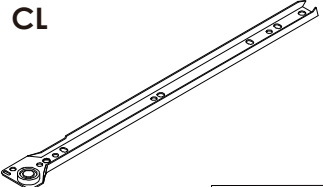
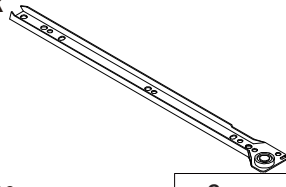
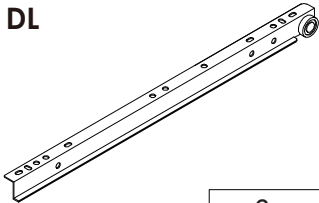
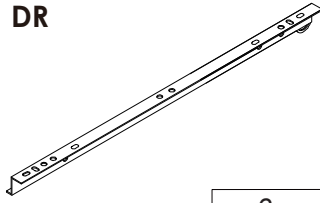
A  M6×35mm 41+5pcs	B  Φ15×9mm 41+5pcs	C  M8×30mm 26+2pcs	D  M6.3 ×40mm 8+1pcs
E  M3.5×12 mm 24+2pcs	F  M4×35mm 18+2pcs	G  M4×14mm 2pcs	H  2pcs
I  M3×16 mm 20+2pcs	J  2pcs	K  20+2pcs	L  M4×14mm 24+3pcs
M  4+1pcs	N  M6×30mm 4+1pcs	O  4pcs	P  1pc
Q  2pcs	R  6+1pcs	S  4pcs	CL  L300mm 2pcs
CR  L300mm 2pcs	DL  L300mm 2pcs	DR  L300mm 2pcs	

STEP 1

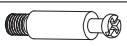
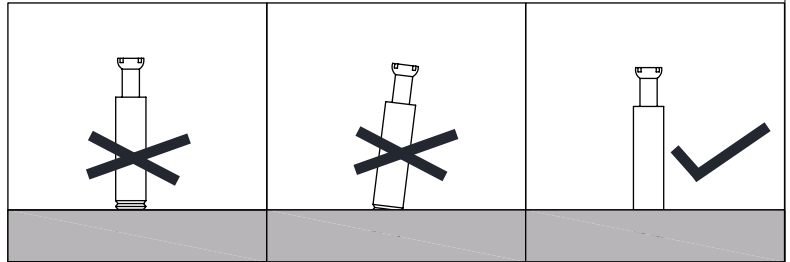
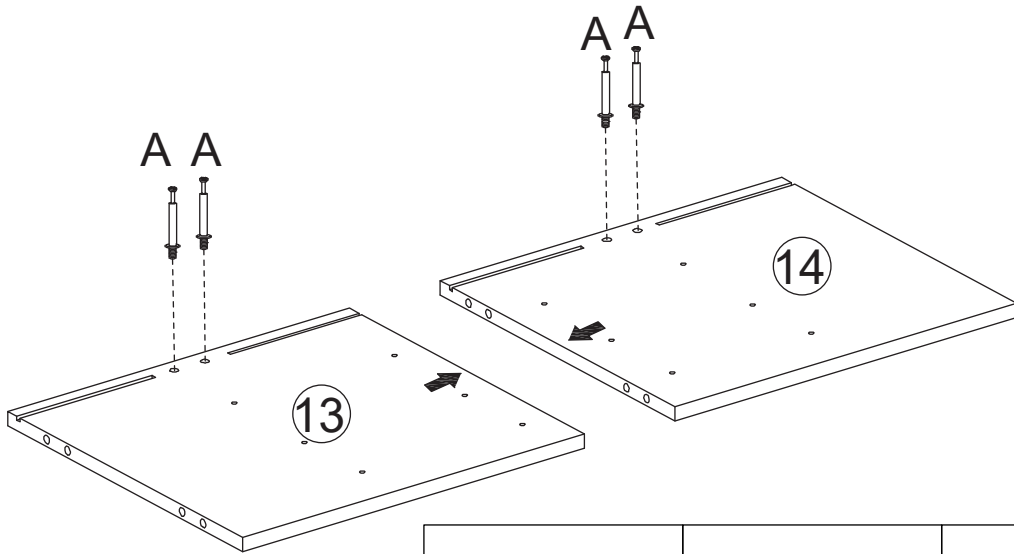

A x 4PCS

STEP 2

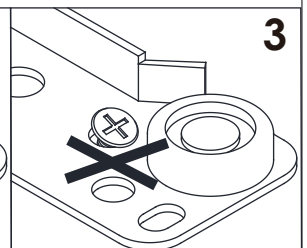
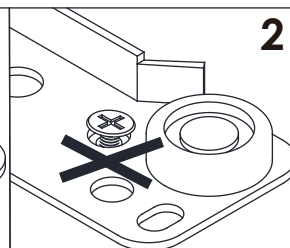
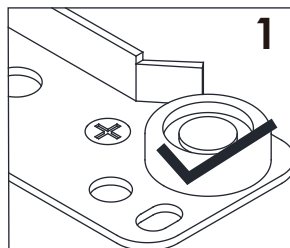
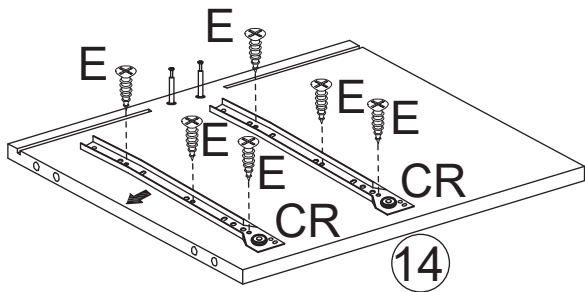
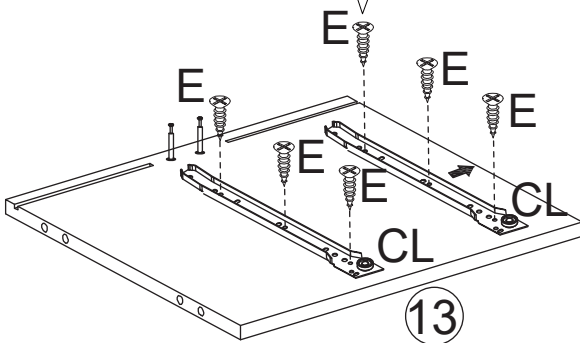
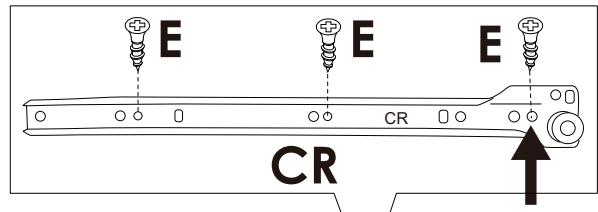
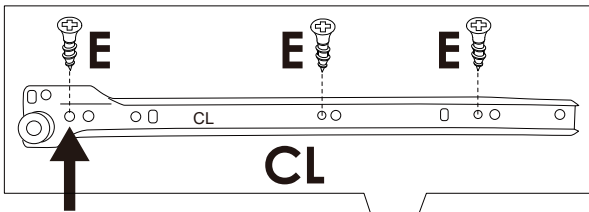

E x 12PCS



CL x 2PCS



CR x 2PCS

STEP 3

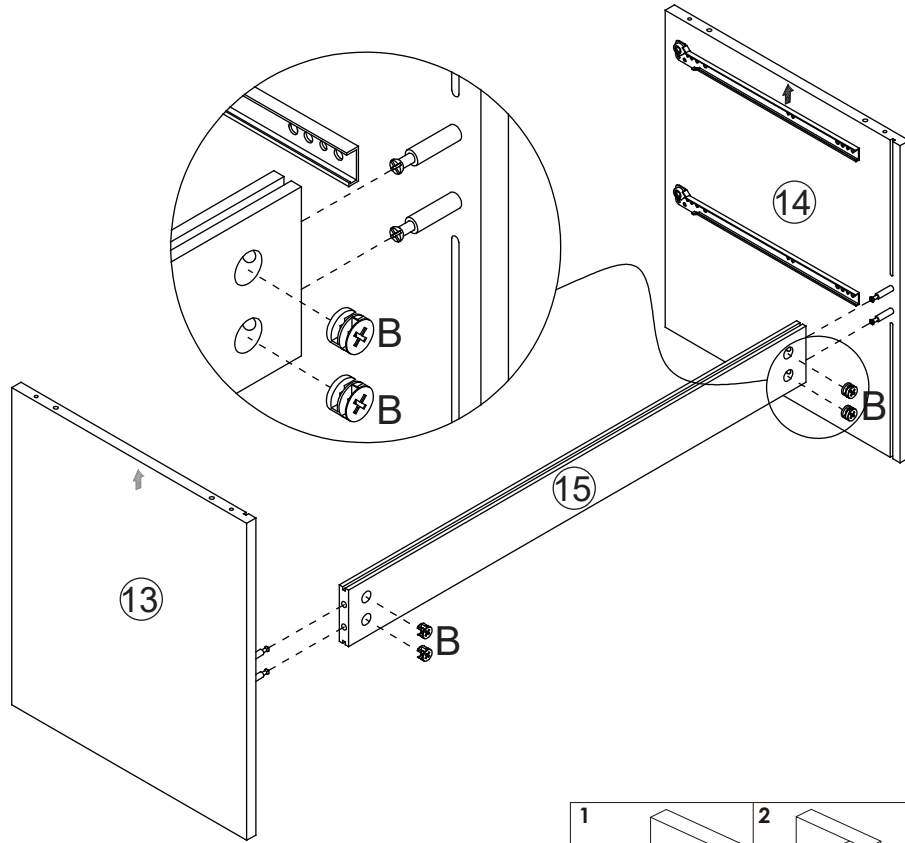

B x 4PCS

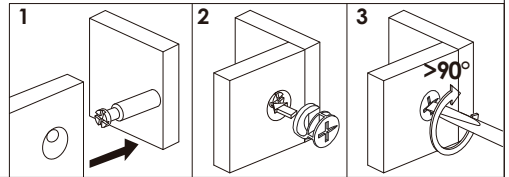

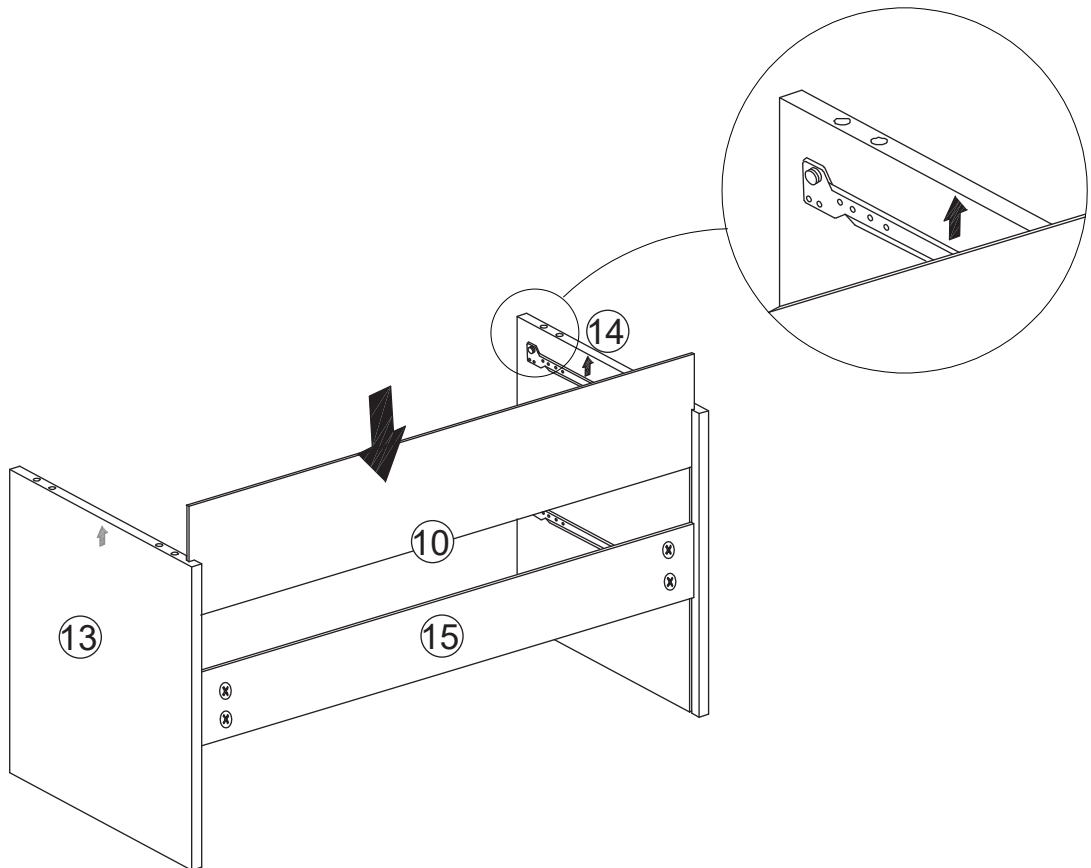

STEP 4

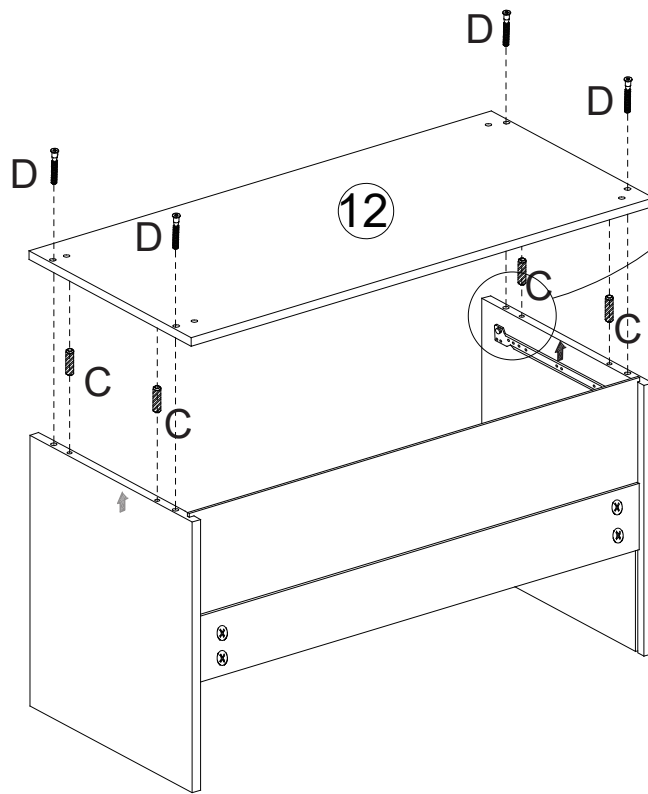

STEP 5



	C x 4PCS
	D x 4PCS

STEP 6

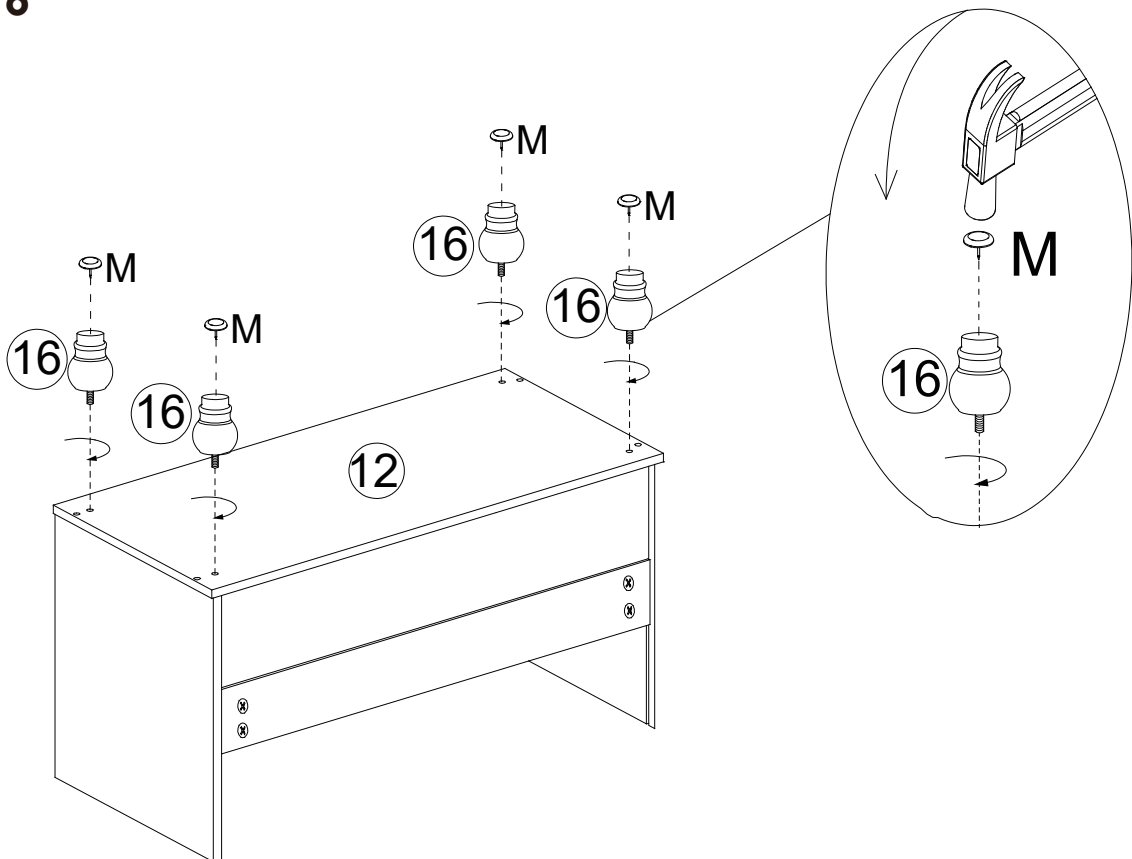

	M x 4PCS
---	----------

STEP 7

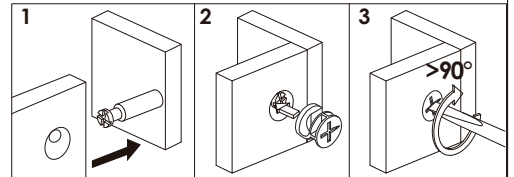
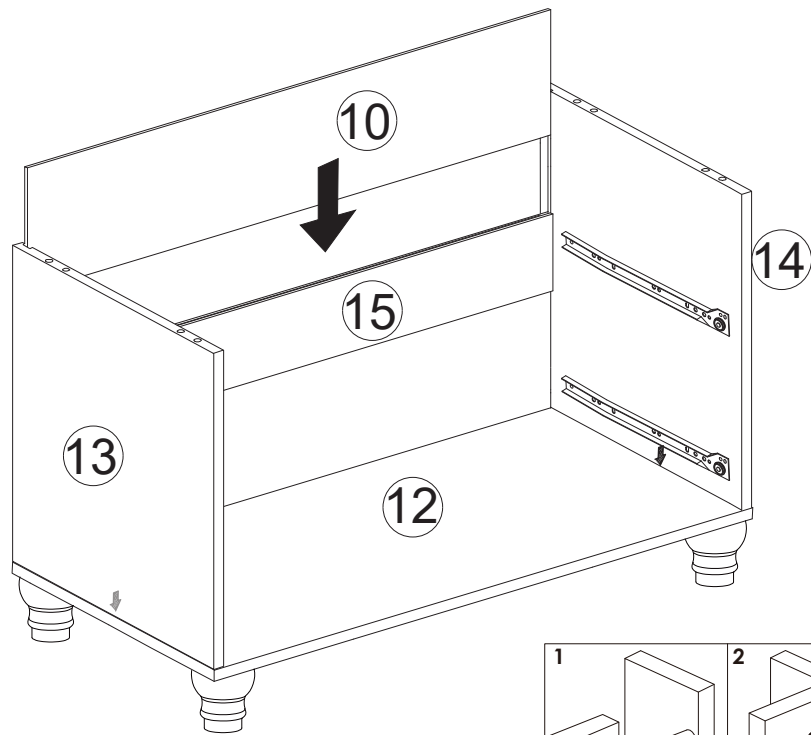

STEP 8

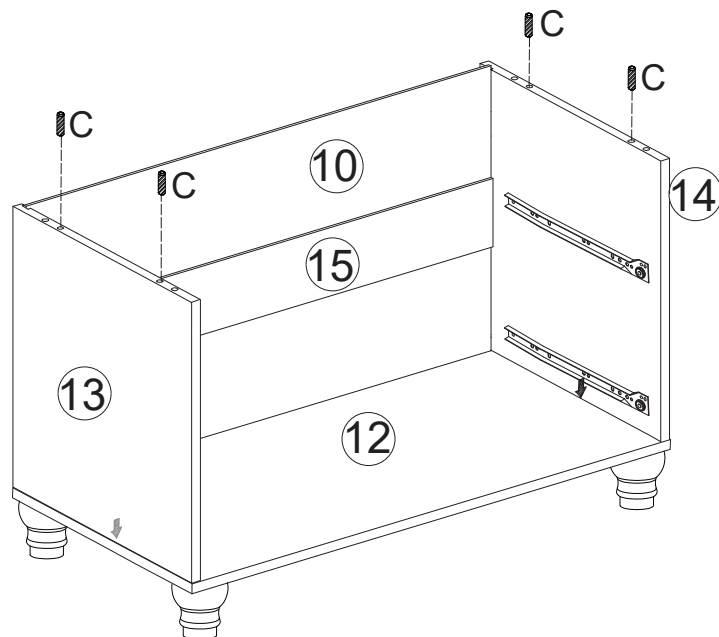

C x 4PCS

STEP 9

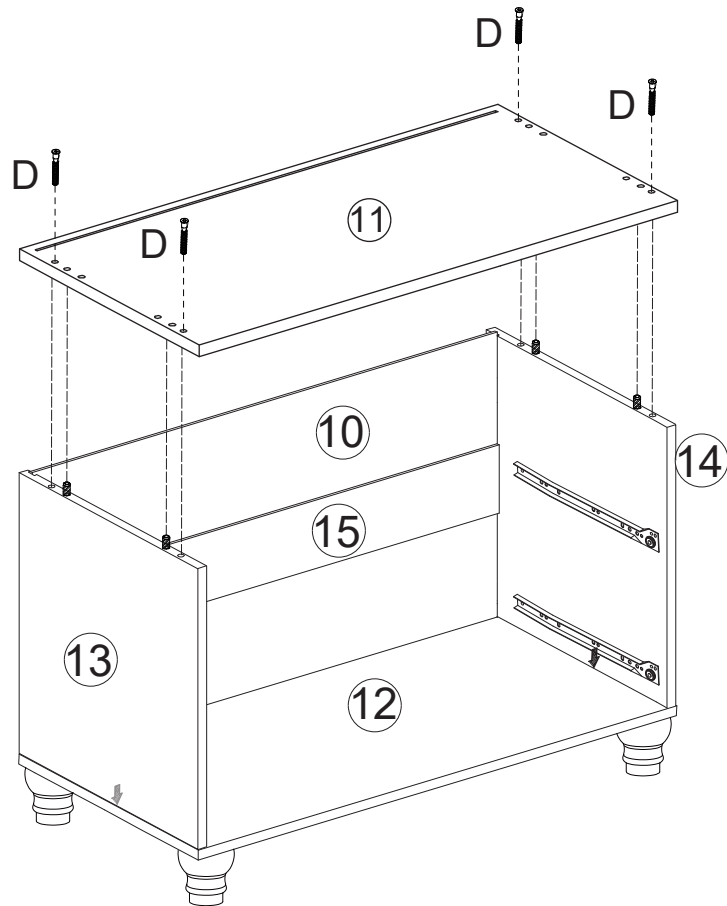

D x 4PCS

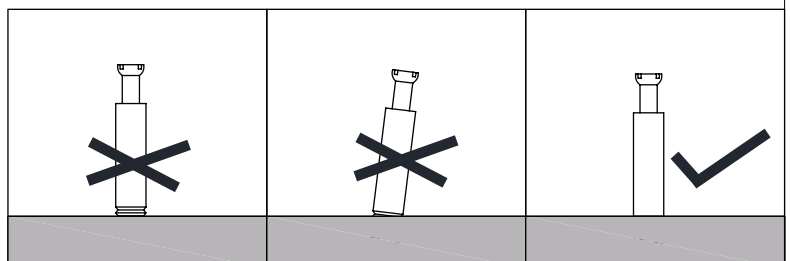
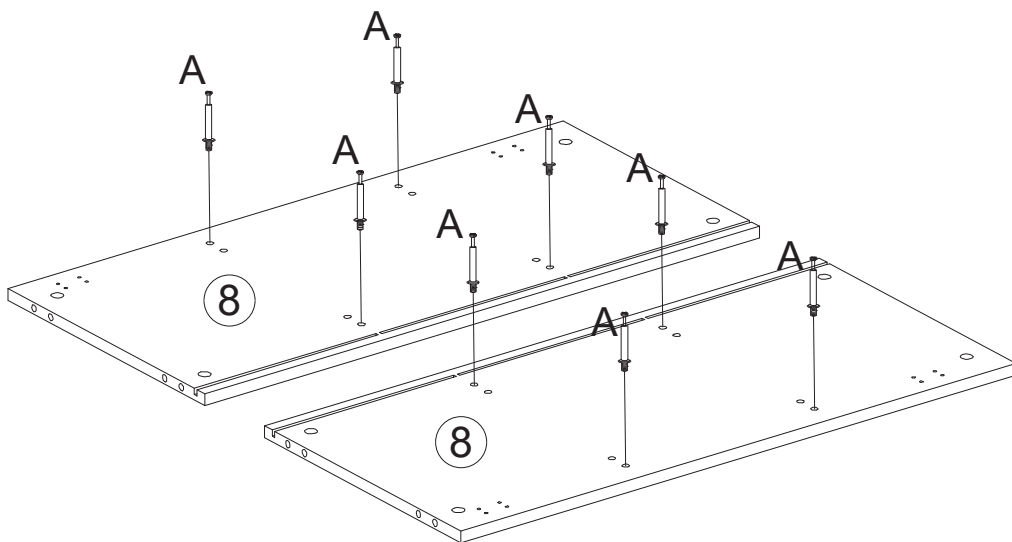

STEP 10

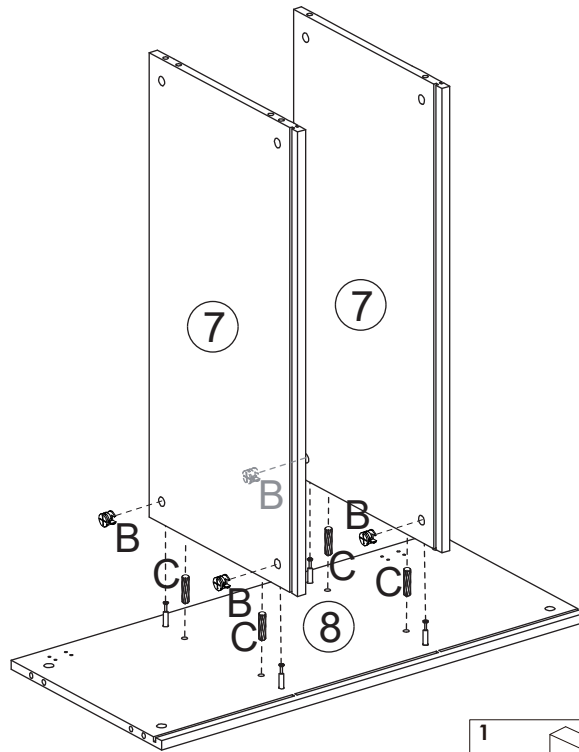

A x 8PCS

STEP 11



	B x 4PCS
	C x 4PCS

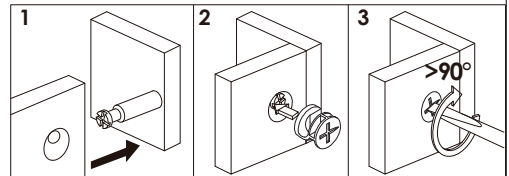

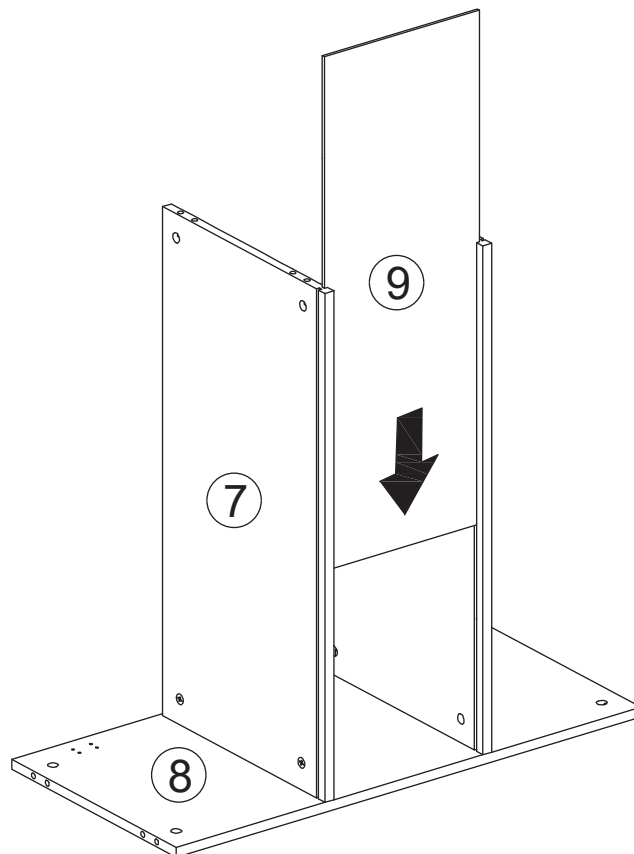

STEP 12

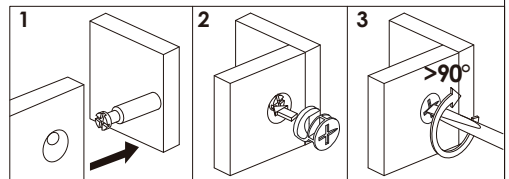
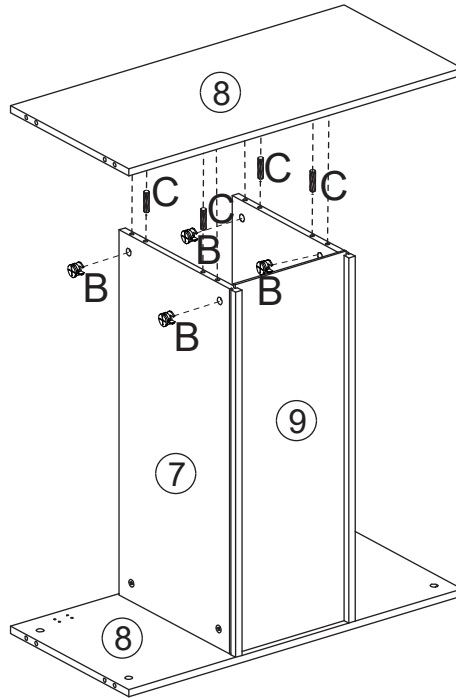

STEP 13



	B x 4PCS
	C x 4PCS

STEP 14

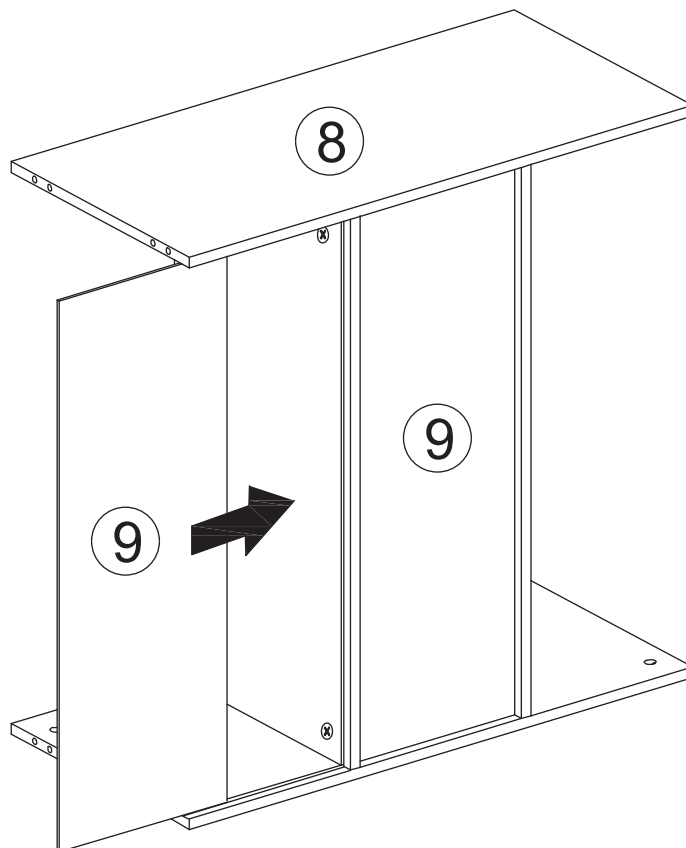

STEP 15

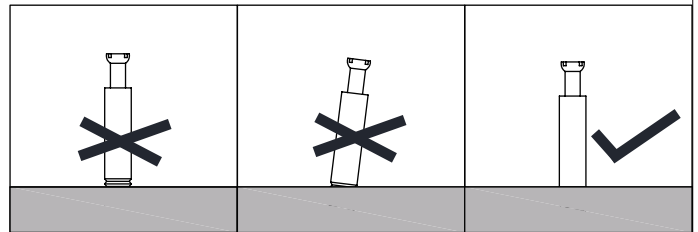
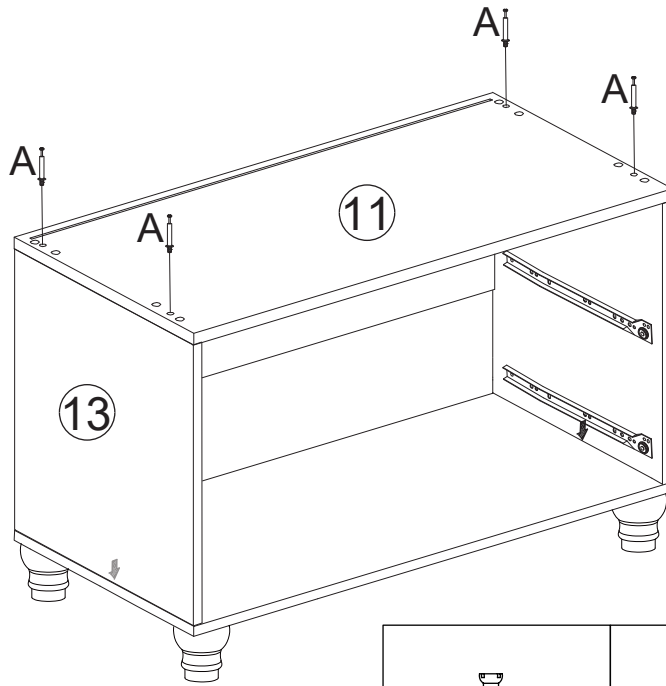

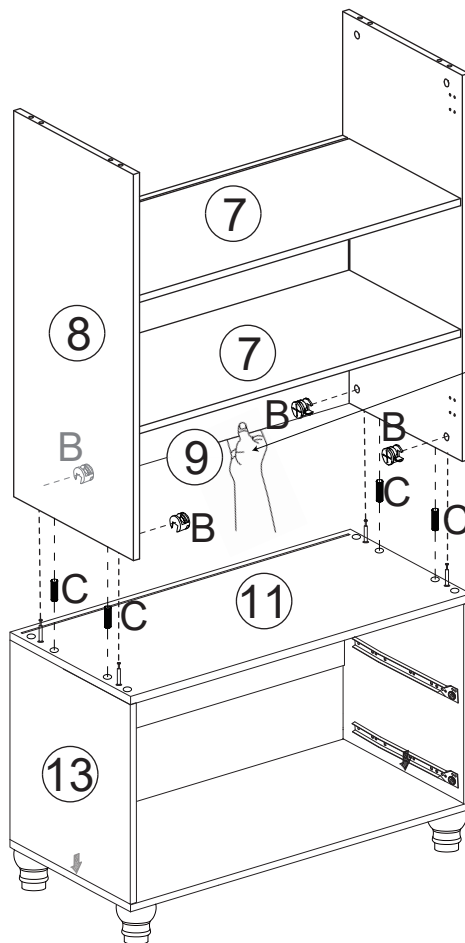

 **A x 4PCS**

STEP 16

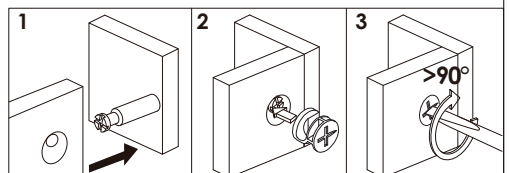

Instruction: Hold it down with your hands.



 **B x 4PCS**
 **C x 4PCS**

STEP 17

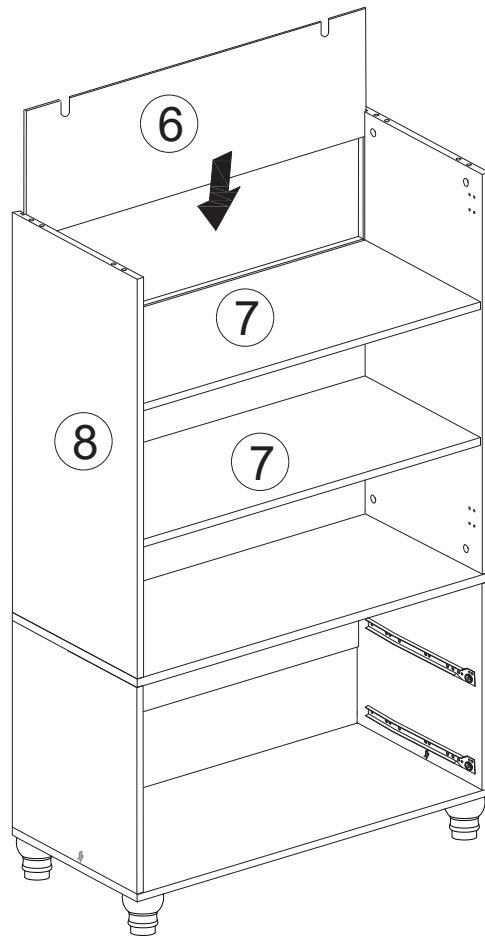

STEP 18

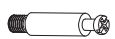
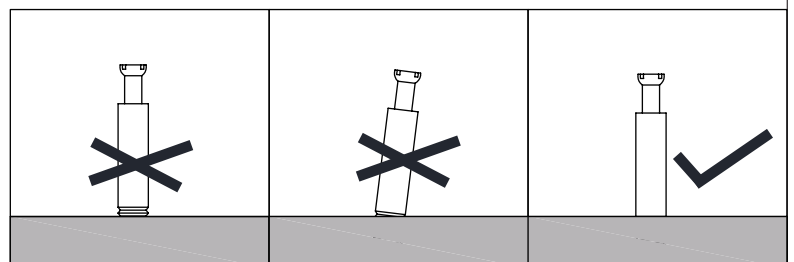
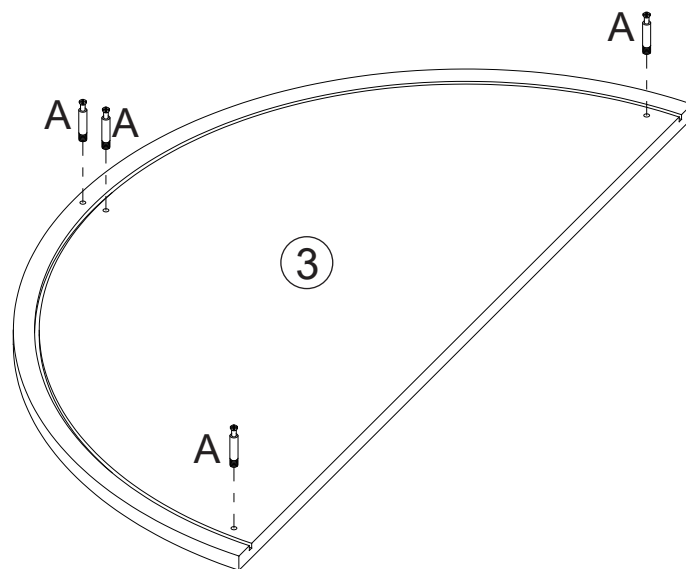

A x 4PCS

STEP 19

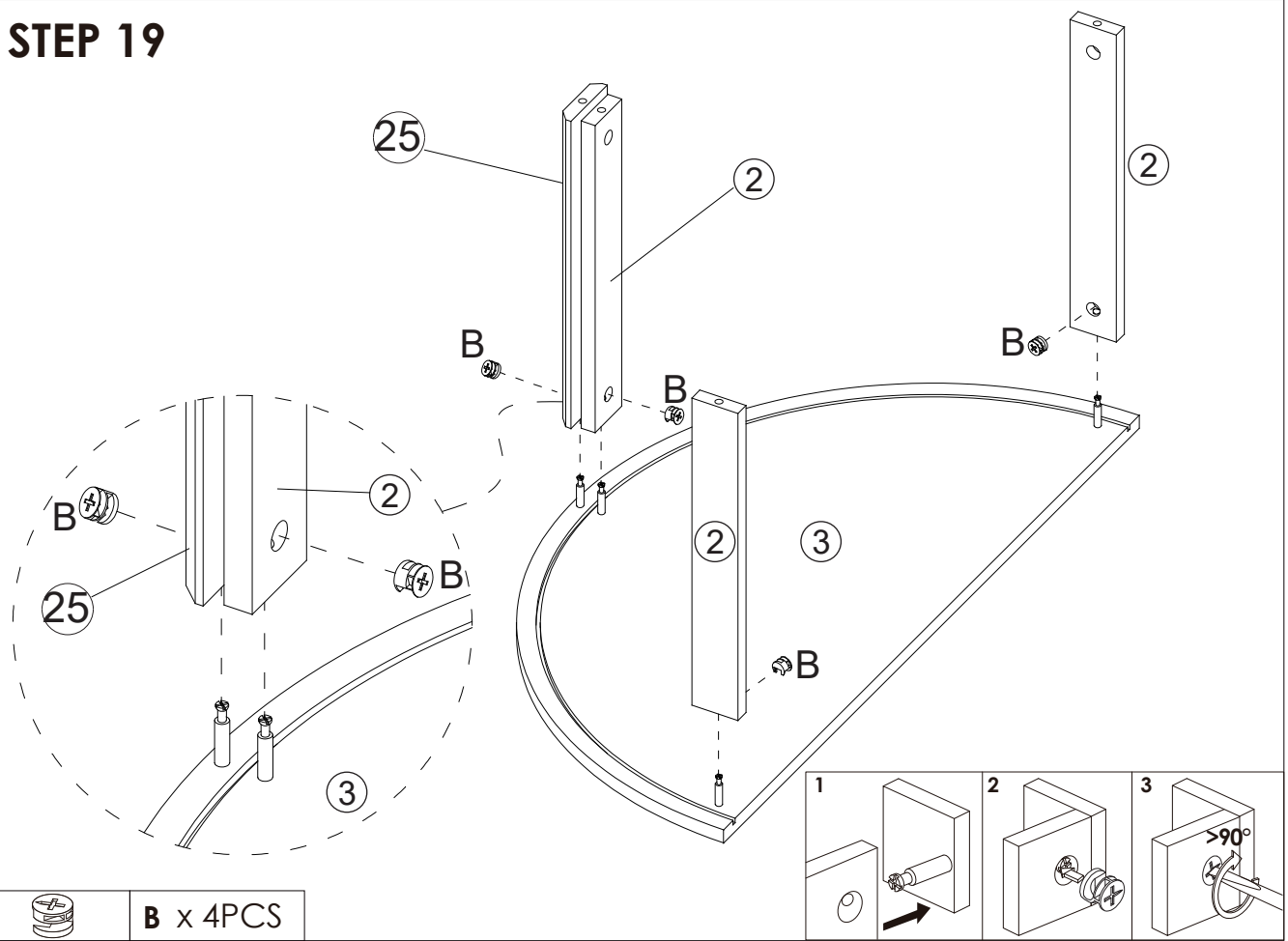

B x 4PCS

STEP 20

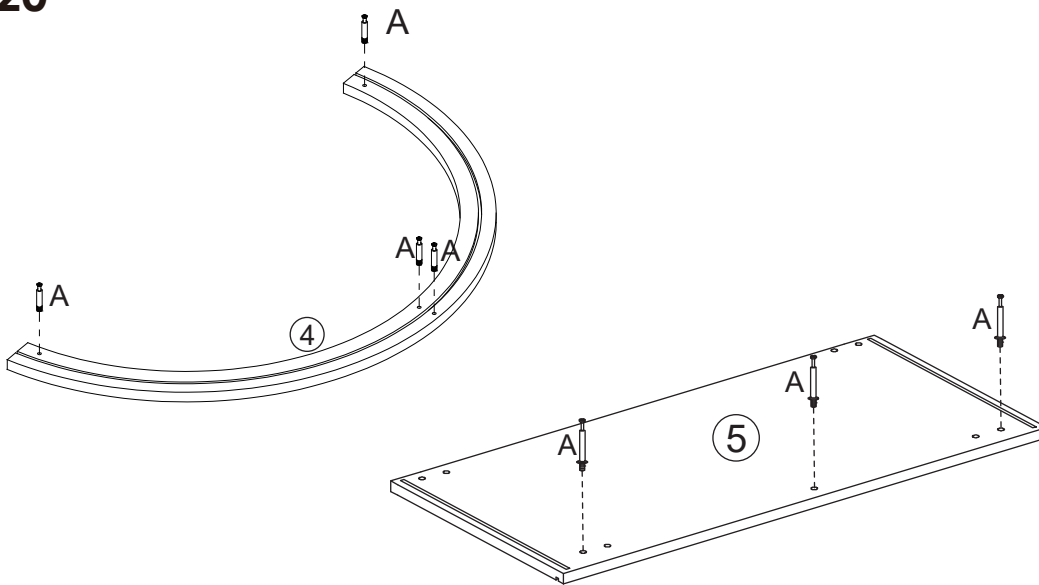

A x 7PCS

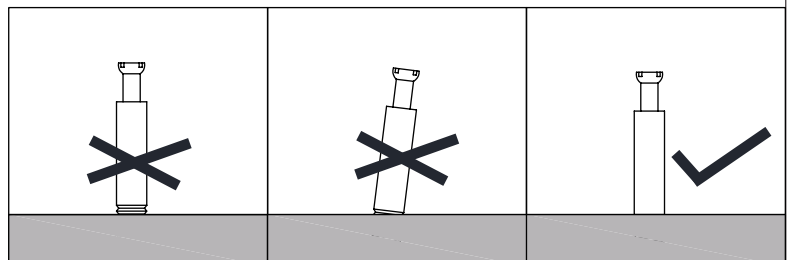

STEP 21

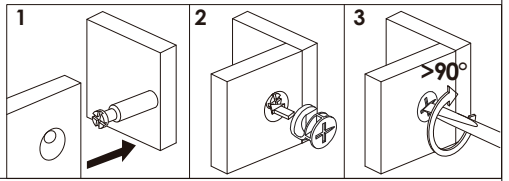
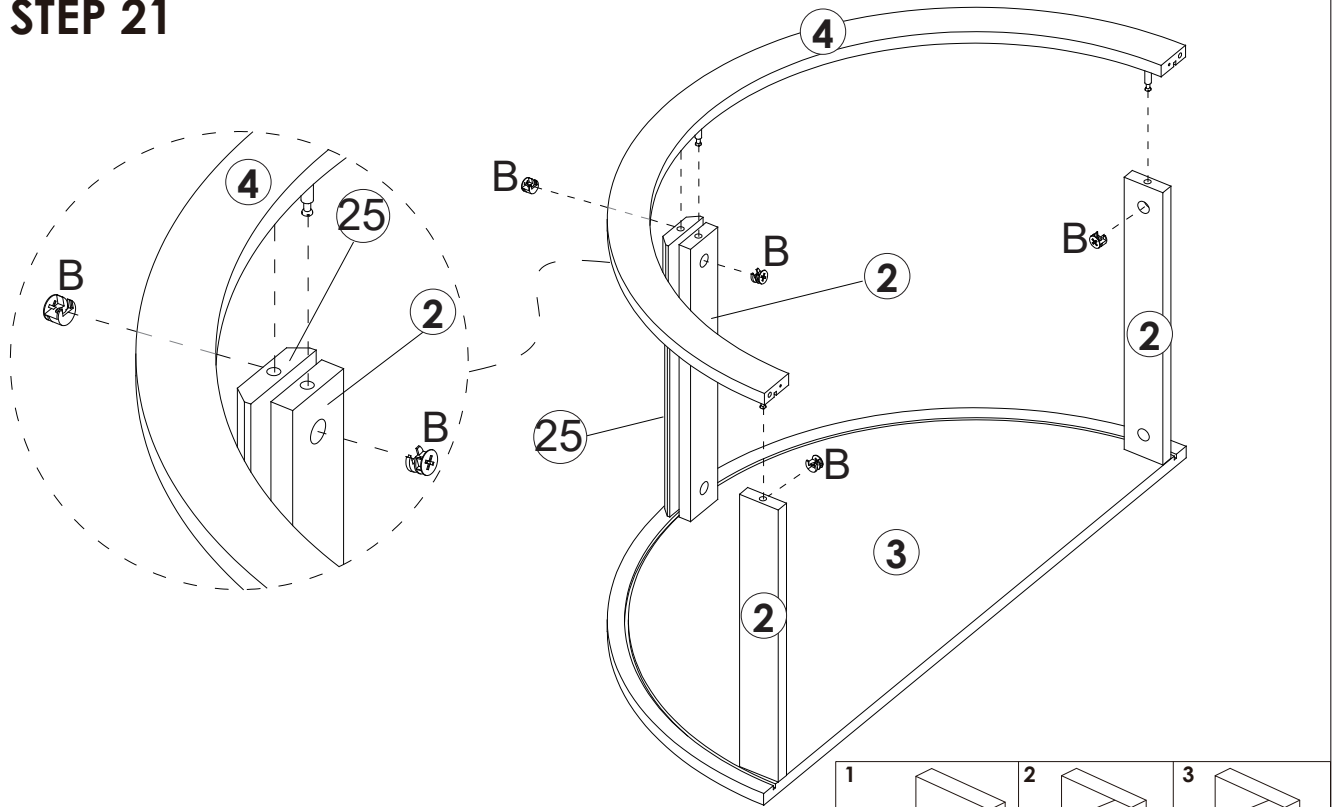

B x 4PCS

STEP 22

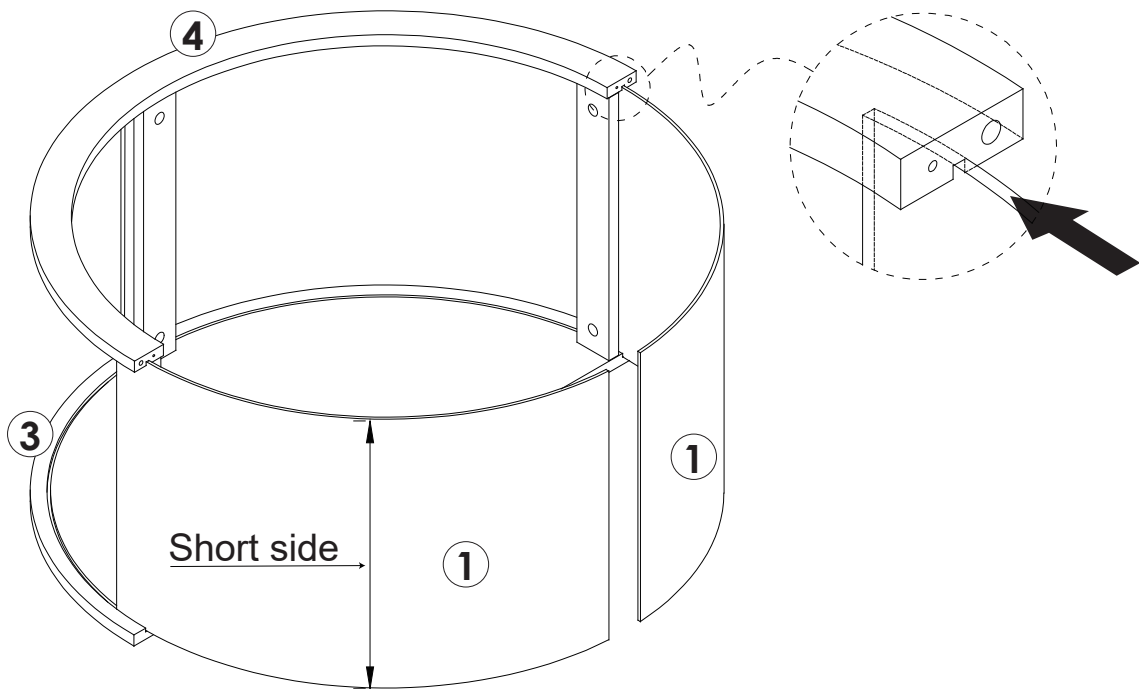
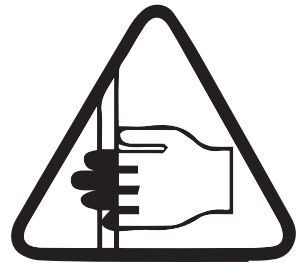



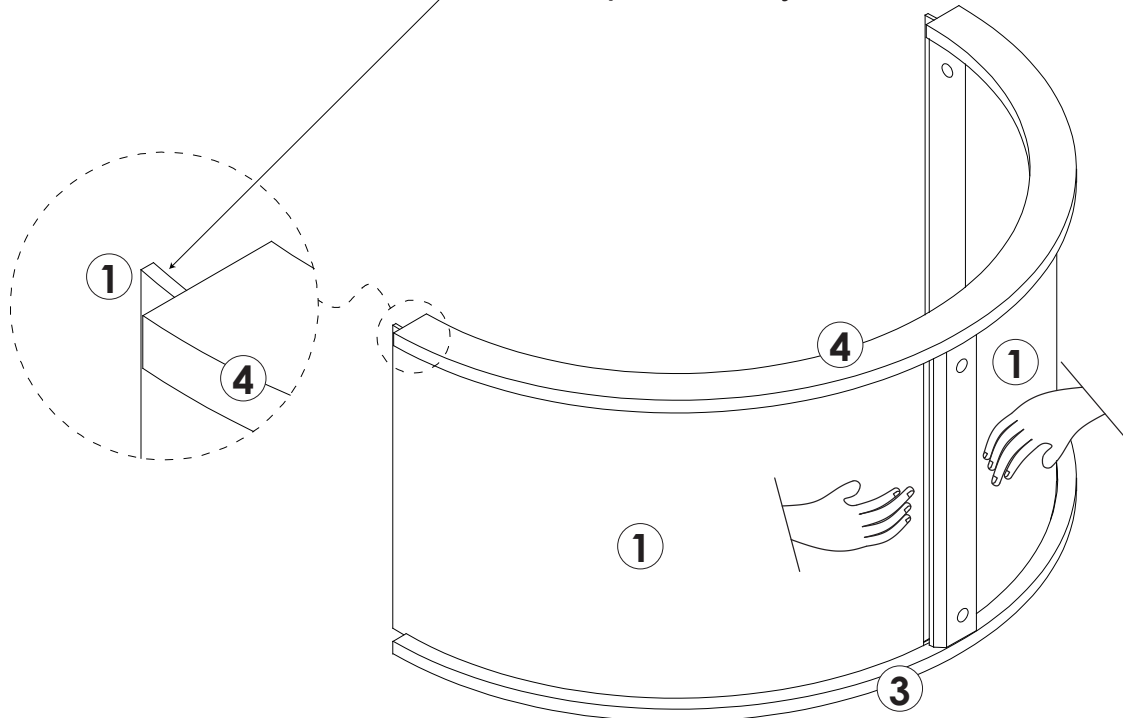

STEP 23

Note: After the 1st board is properly installed, it will protrude by 4mm.

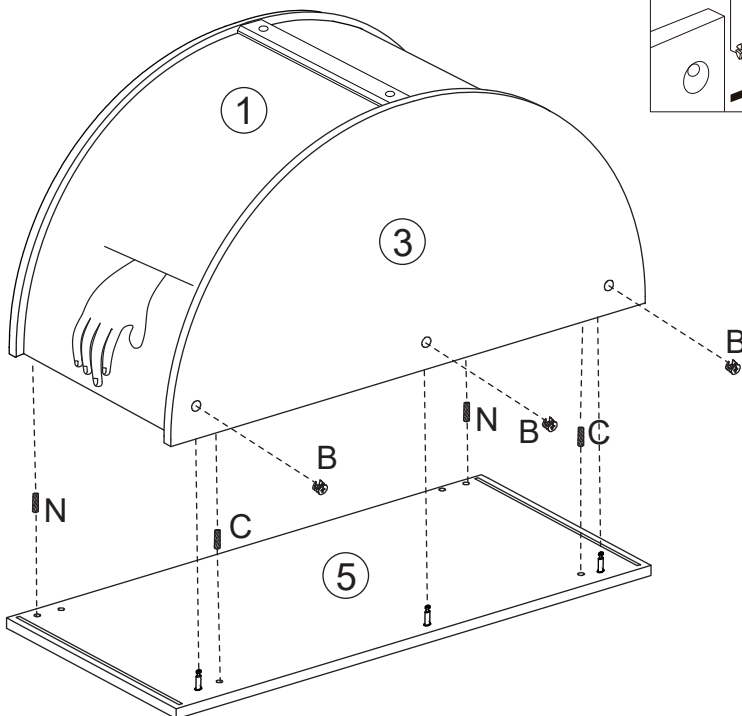
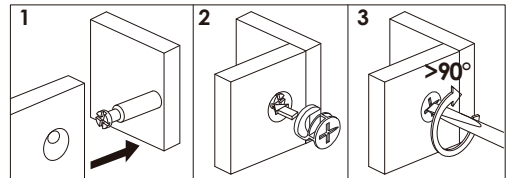

STEP 24



	B x 3PCS
	C x 2PCS
	N x 2PCS

Note: After installing the 5 board, you need to pat the 1 board on both sides into the grooves of the 5 board by hand. Then install the tightening nuts B.

STEP 25

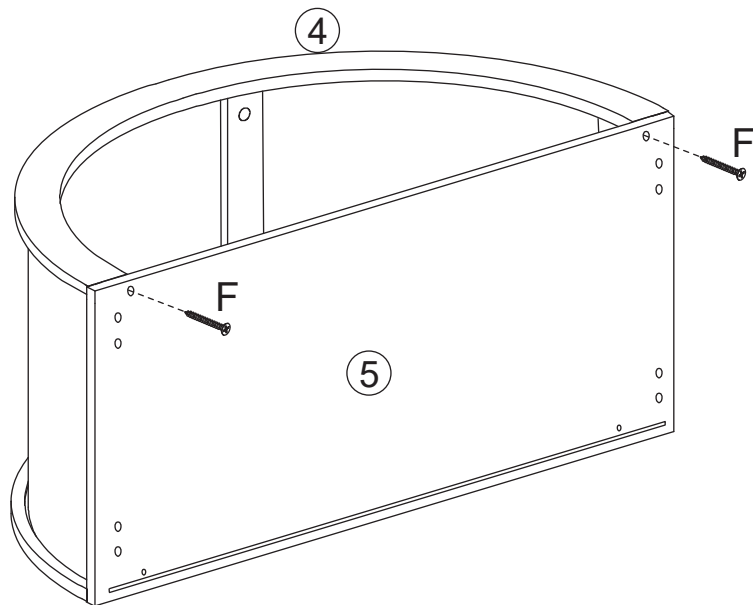



 **F x 2PCS**

STEP 26

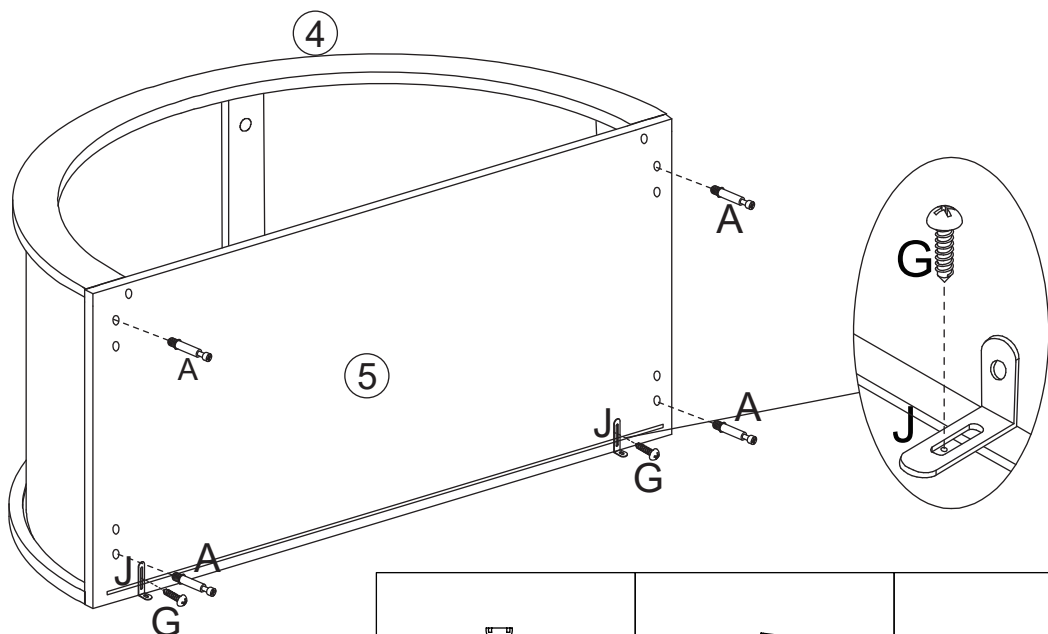
Lock screw G onto board 5 with screw J .

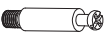

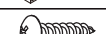

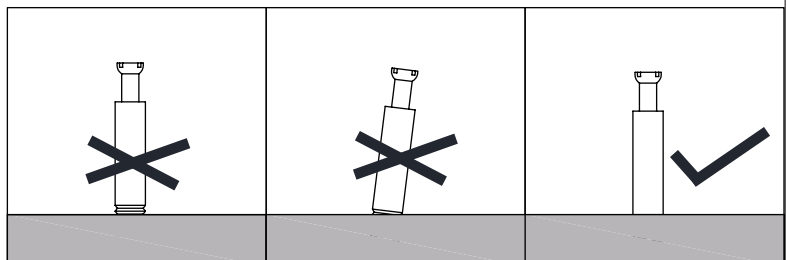
	A x 4PCS
	J x 2PCS
	G x 2PCS

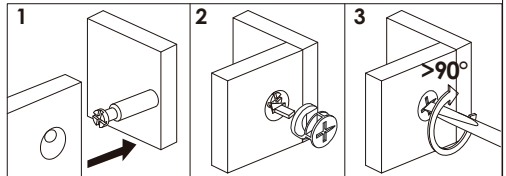
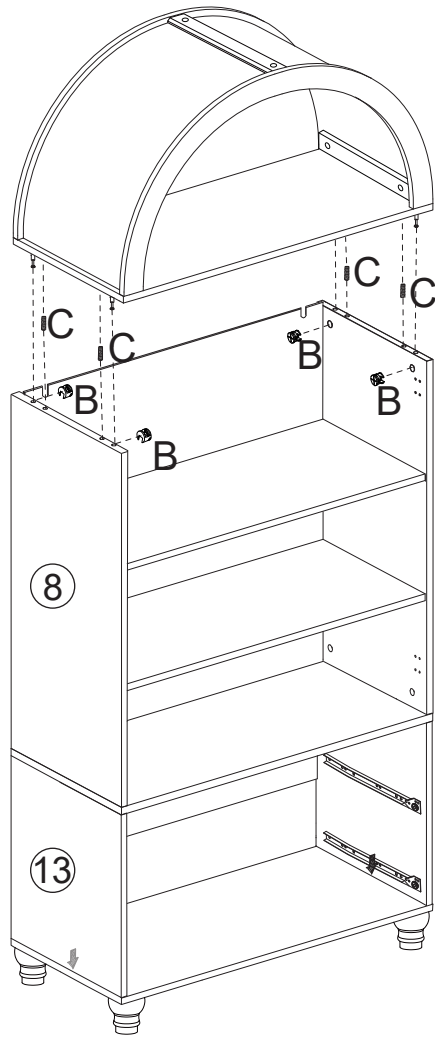

STEP 27



	B x 4PCS
	C x 4PCS

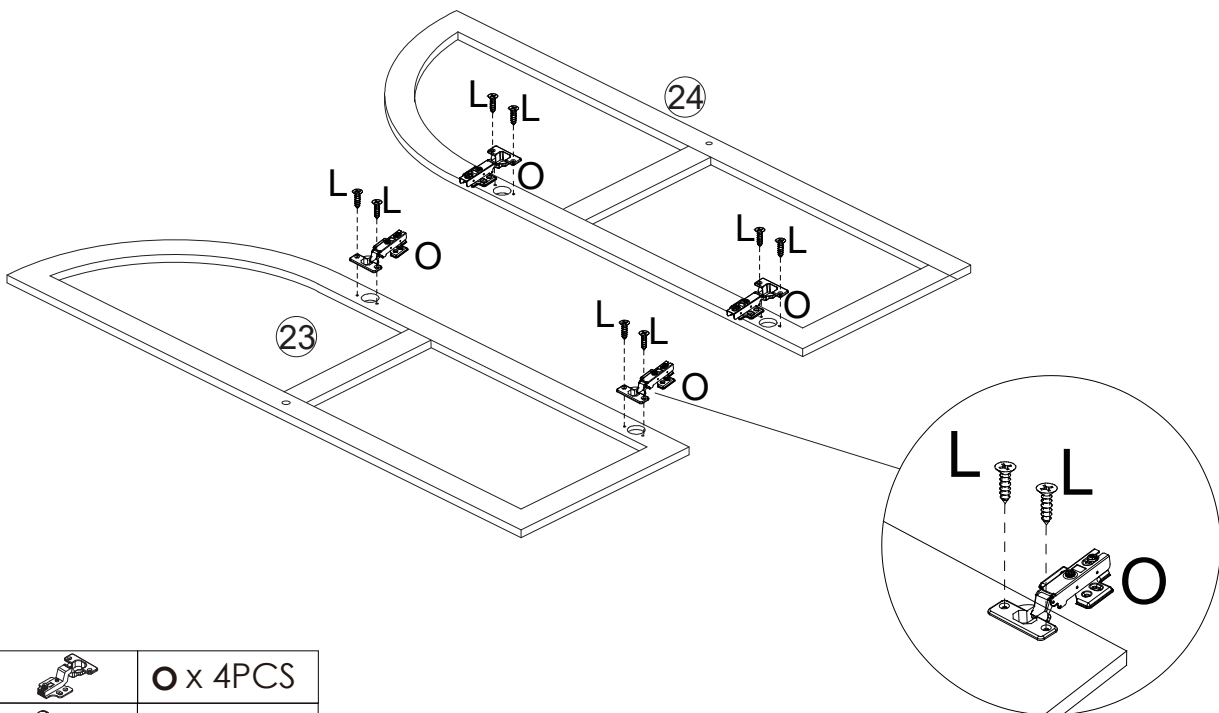

STEP 28

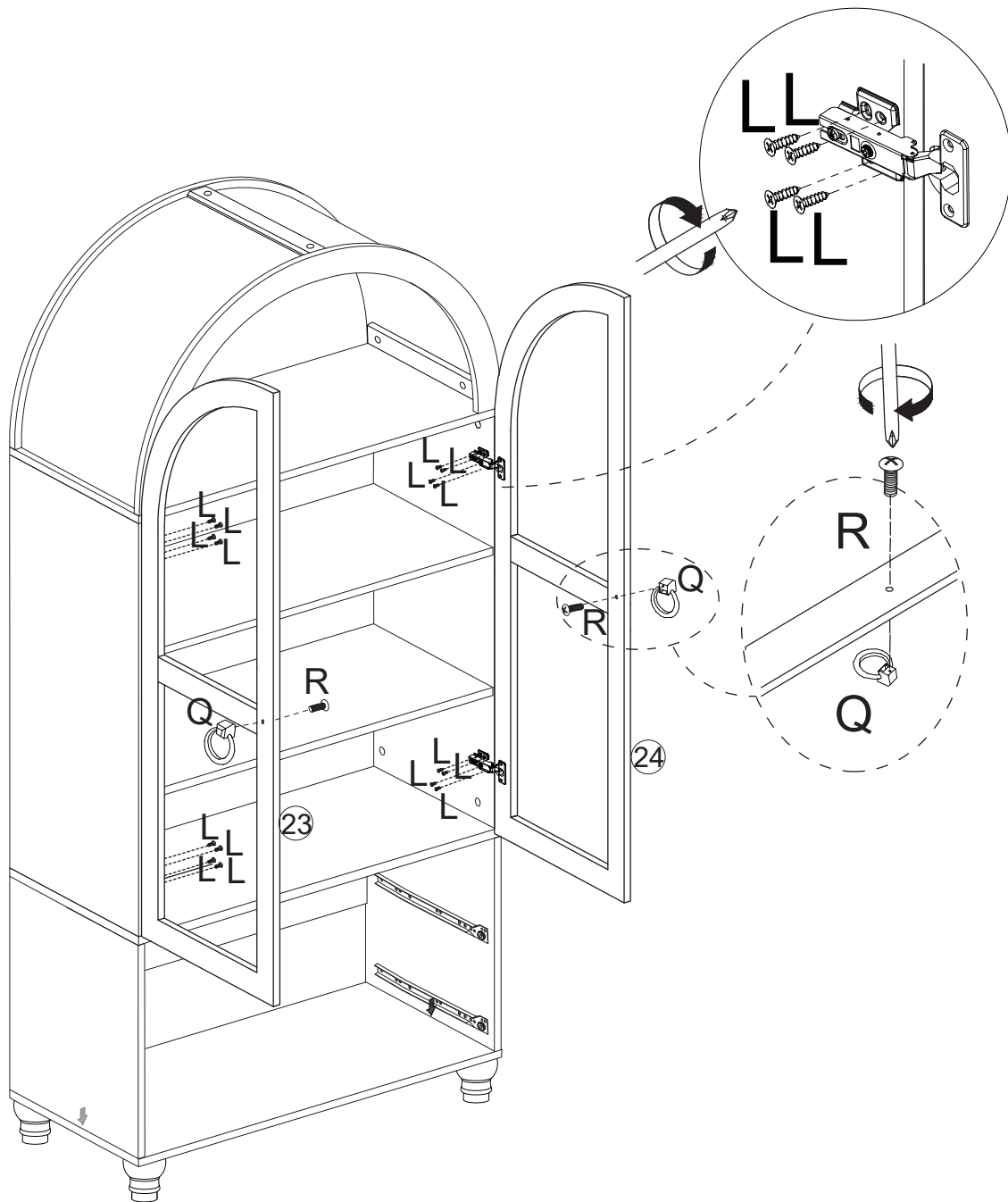

	O x 4PCS
	L x 8PCS

STEP 29



	L x 16PCS
	R x 2PCS
	Q x 2PCS

The ways to adjust the door

- Before adjusting the hinge, please check whether the cabinet is skewed.
- If the skew can not be repaired, please remove the anti-tipping device first, then adjust the cabinet to vertical position.
- Please adjust the hinge with the door open.
- Please operate it with more than 2 people, one person holds the door and the other one adjusts the screw.

Components Name

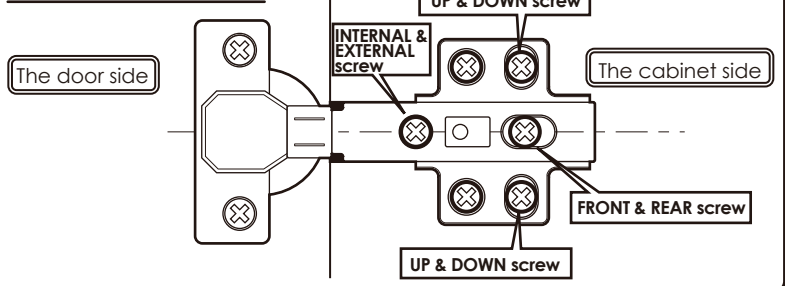

Obvious gaps between doors or Doors don't look closed

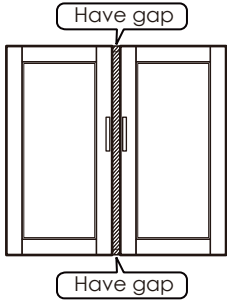

- 1 Turn "internal & external screw" to the right can make the door approach inside. Please adjust the doors little by little.

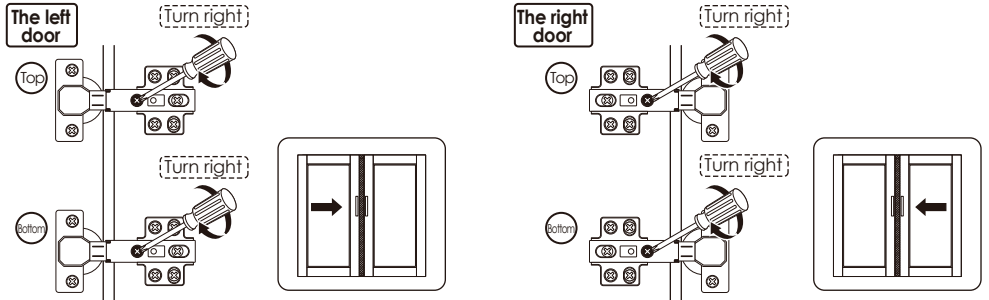

※ If the 2 doors are overlap, please turn the "internal & external screw" to the left.

When door is crooked



Please take the following steps to adjust first.

- 1 Rotate the "front and rear screws" to the left

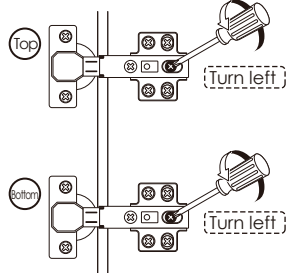

※ After adjusting the "front and rear screw", the door still does not change, please turn the "internal & external screw" to the right slightly.

- 2 Push the door to the cabinet

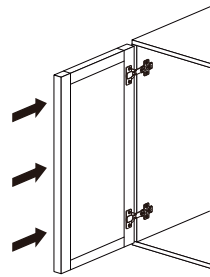

- 3 Rotate the "front and rear screws" to the right

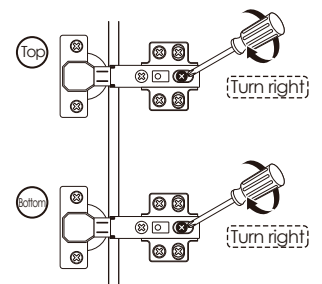

When door is leaning

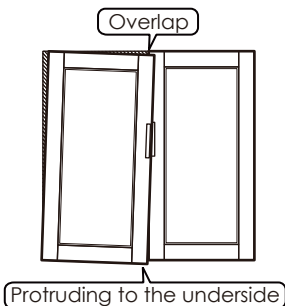

- 1 Turn "internal & external screw" to the left can make the top of the door tilted outward.

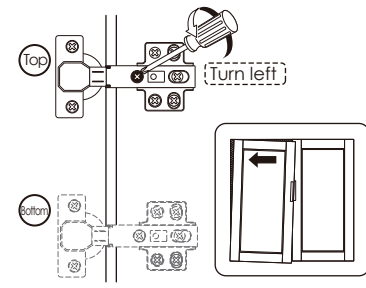

Protruding to the upside



- 1 Turn "internal & external screw" to the left can make the bottom of the door tilted outward.

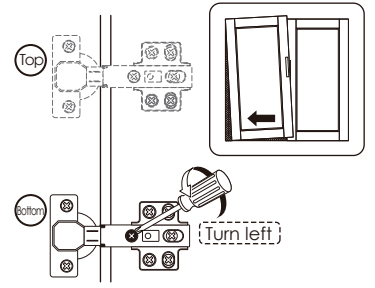

When the door is higher on top

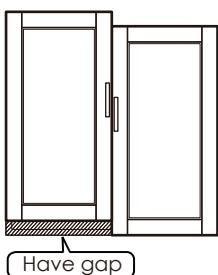

- 1 Turn "up & down screw" to the left

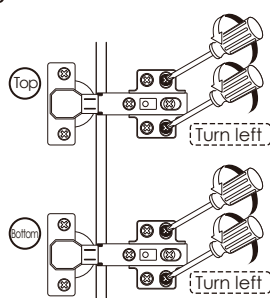

- 2 Lower the door's height so that 2 doors are of the same height.

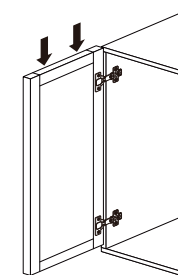

- 3 Turn "up & down screw" to the right

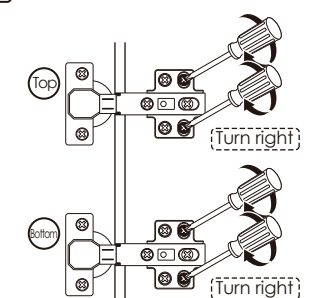

※ If the door is lower on bottom, please lift up the left door slightly on step 2

STEP 30

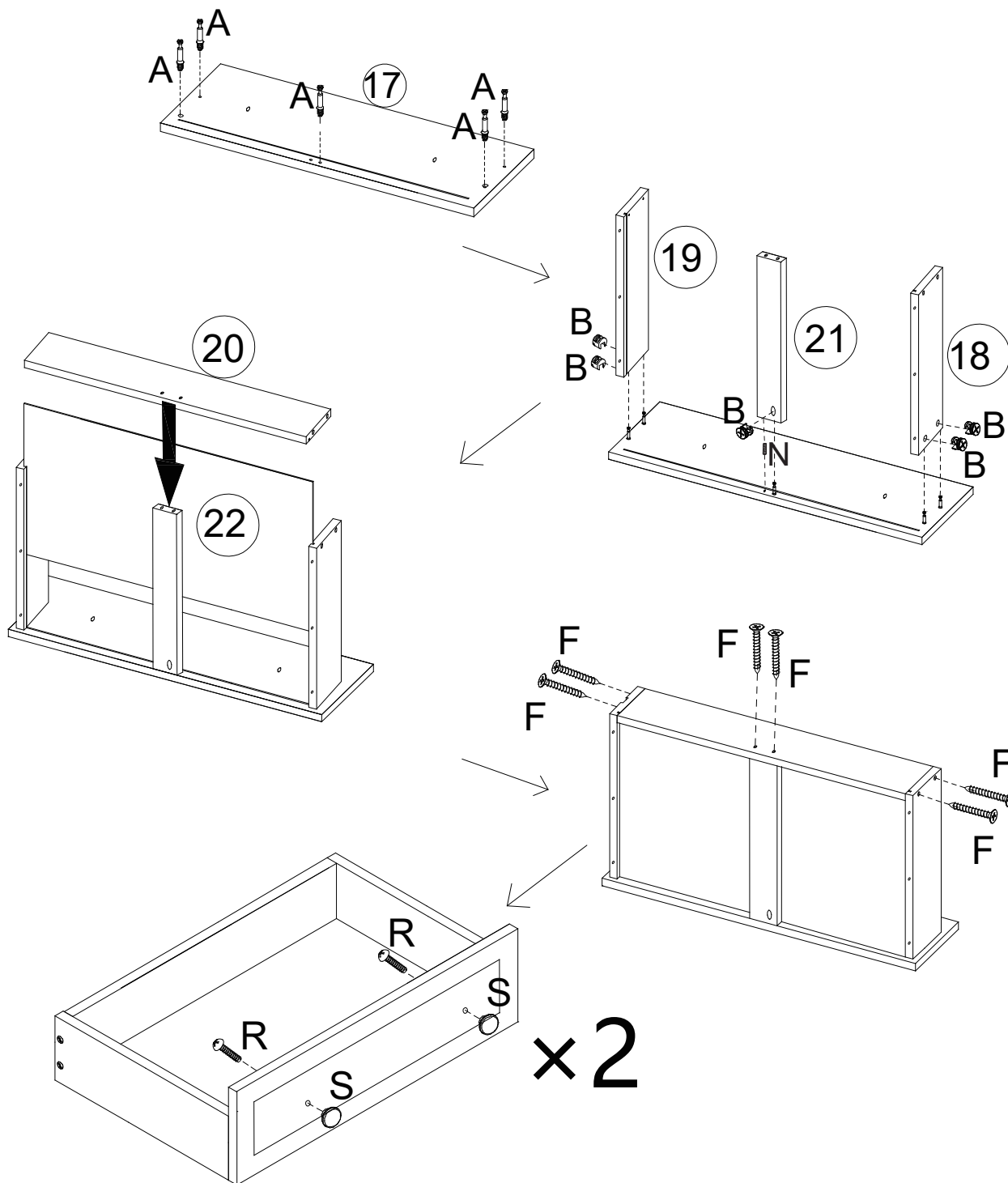

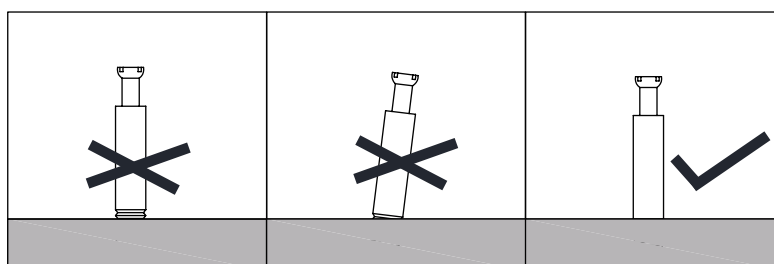

	N x 2PCS
	A x 10PCS
	B x 10PCS
	F x 12PCS
	R x 4PCS
	S x 4PCS

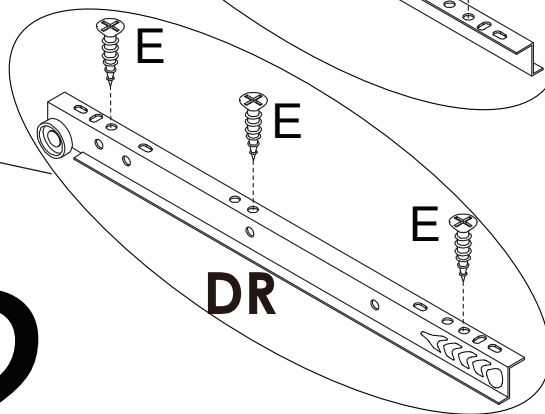
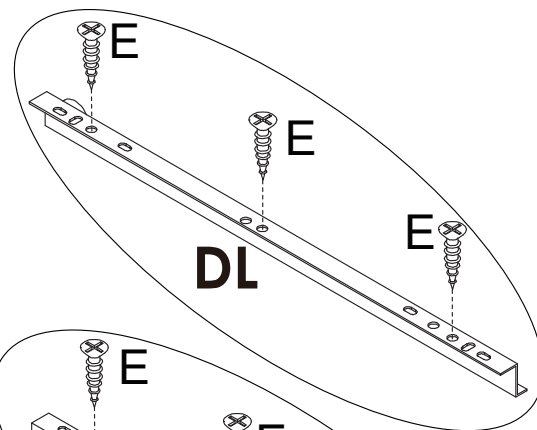
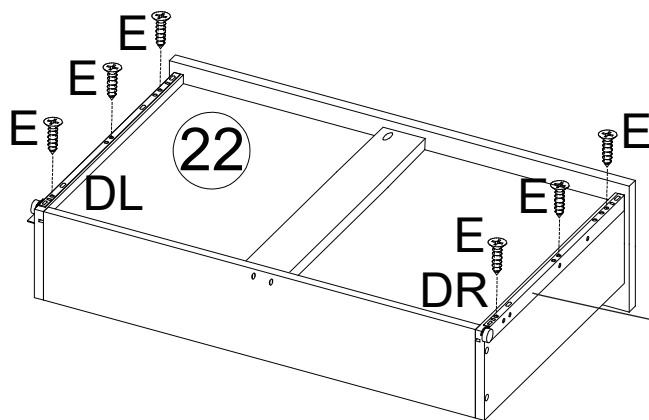

STEP 31



x 2

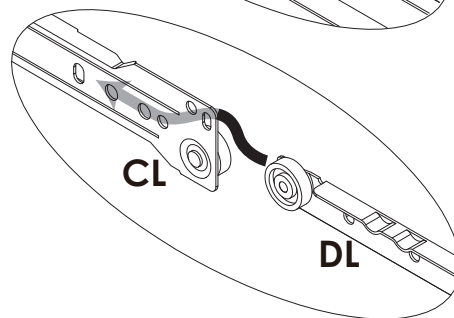
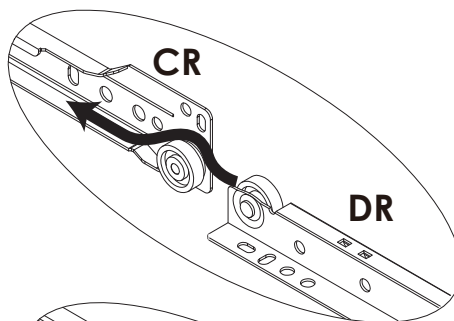
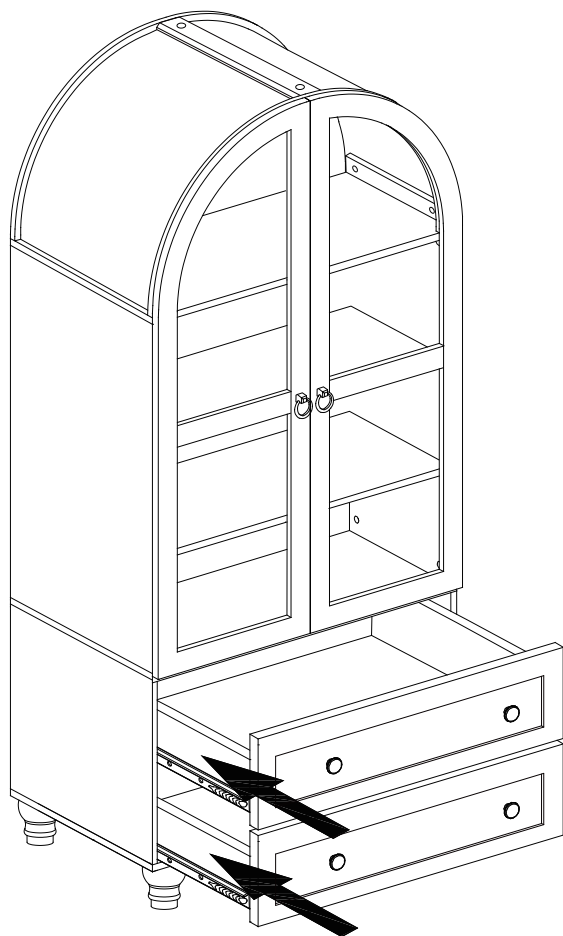

	E x 12PCS
	DL x 2PCS
	DR x 2PCS

STEP 32

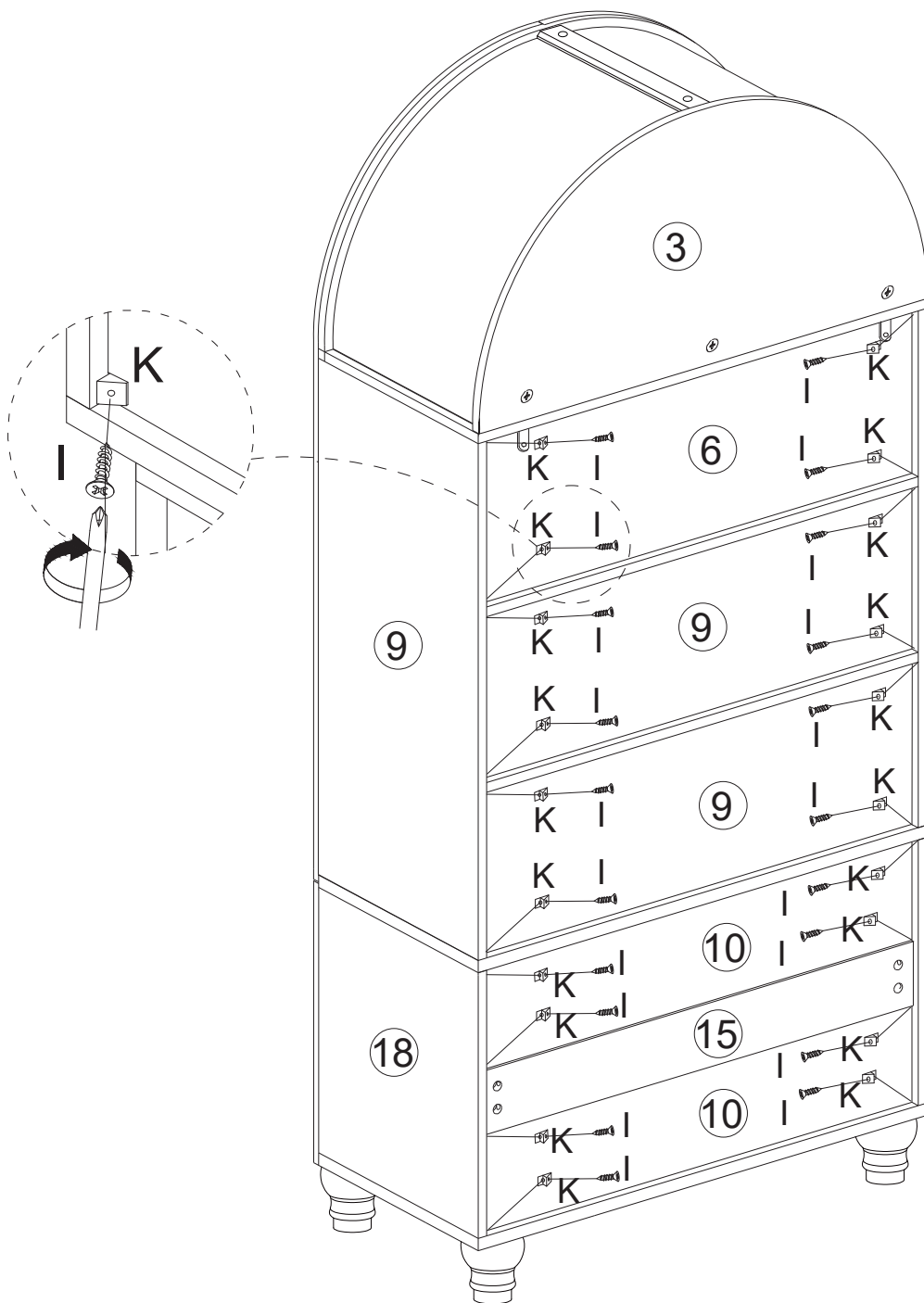

STEP 33



	I x 20PCS
	K x 20PCS

STEP 34

Drill 2 holes on the wall at the required position for anti-falling device installation.

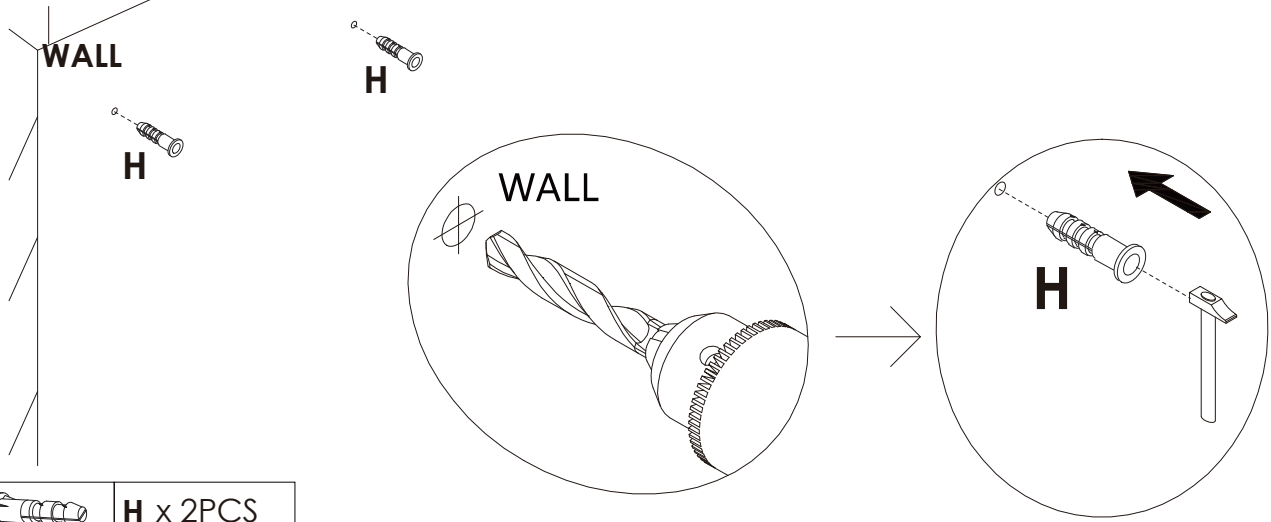

 H x 2PCS

STEP 35

Move the cabinet to the required position, use the "F" long screw to fix the cabinet to the wall.

WALL

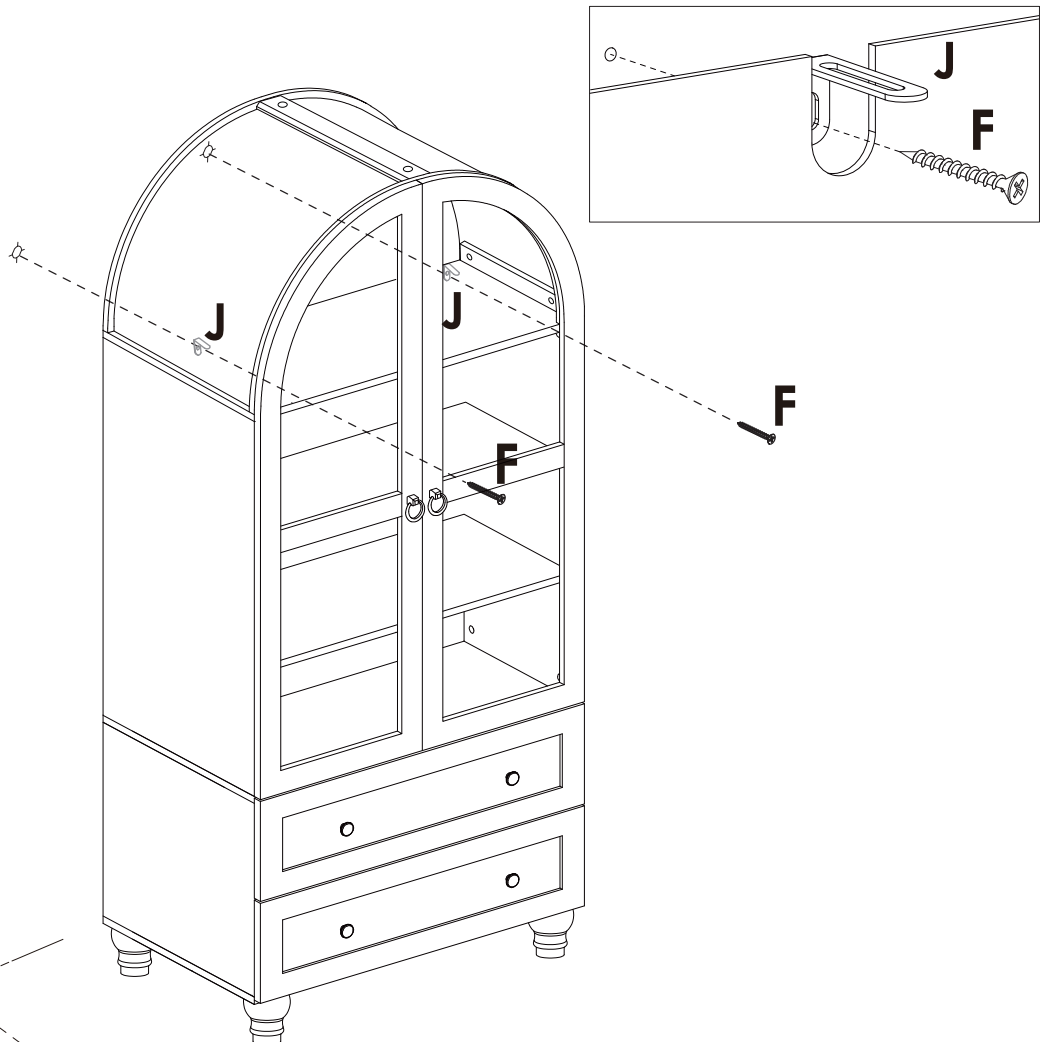

 F x 2PCS



WARNING



Children have died from furniture tipover. To reduce the risk of furniture tipover:

- **ALWAYS** install Anti-tip device provided.
- **NEVER** put a TV on this product.
- **NEVER** allow children to stand, climb or hang on any drawers, doors, or shelves.
- **NEVER** open more than one drawer at a time.
- Place heaviest items in the lowest drawers.



***This is a permanent label.
Do not remove!***