

ASSEMBLY INSTRUCTION







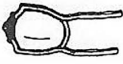

DESCRIPTION: SIDE CHAIR

Read instruction carefully prior to assembly .

Thank you for purchasing this quality product. Check carefully for small parts which may have come loose during shipment.

Remove all components from pack and place table top upside down on soft surface such as carpet or cloth to prevent scratching the finish. Identify and count all parts as specified below.

Do not tighten bolts until assembly is complete

NO.	HARDWARE PACK	Q'TY	NO.	PARTS LIST	Q'TY
A	 ALLEN BOLT (Ø5/16**75mmL)	4PCS	1		CHAIR BACK 1PC
B	 ALLEN BOLT (Ø5/16**50mmL)	4PCS			
C	 ALLEN BOLT (Ø5/16**38mmL)	2PCS	2		CUSHION SEAT 1PC
D	 LOCK WASHER (Ø5/16")	10PCS			
E	 FLAT WASHER (Ø5/16")	10PCS	3		LEGS 2PCS
F	 ALLEN KEY (4MM)	1PC			

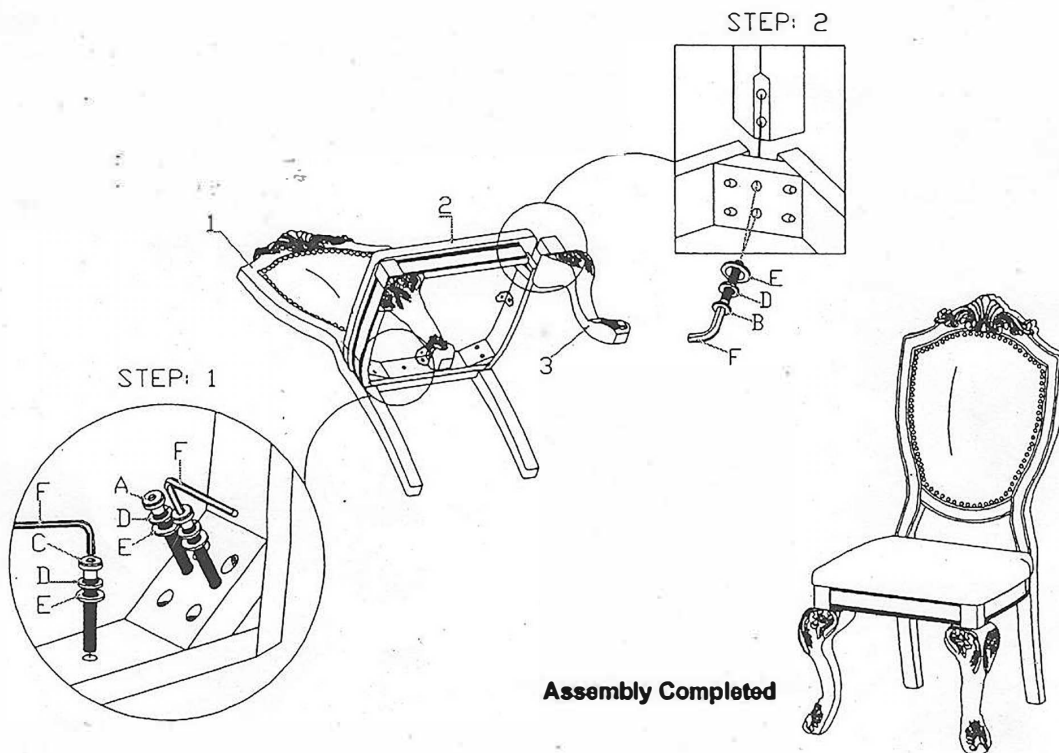

Cleaning Instructions: Clean using soft cloth