

SPIGOT HANDLE WITH CARTRIDGE HOOK KIT (2-PACK)

NEED HELP OR ADVICE ON PUTTING THIS KIT TOGETHER? MISSING
PIECES? EMAIL US AT OUR WEBSITE FOR ANY QUESTIONS

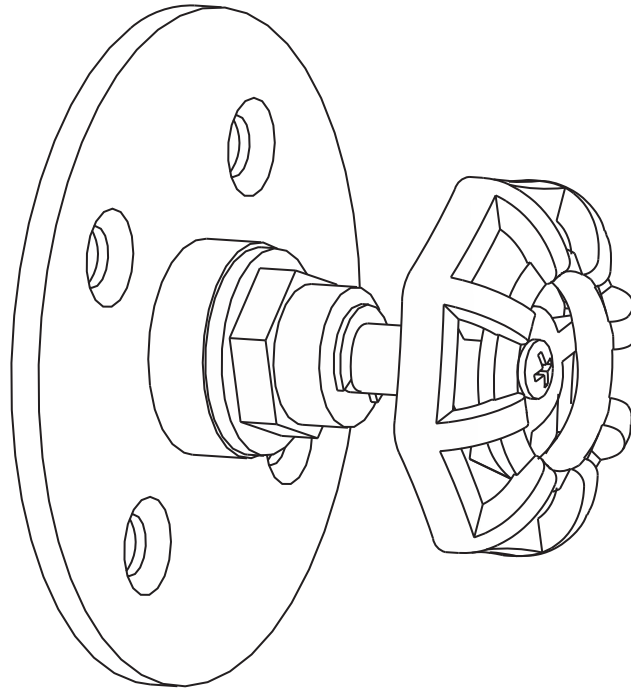

HOW TO PREVENT PIPE CORROSION

Our industrial-grade black pipes and fittings are coated with a rust-preventive oil during manufacturing. For best results, **SEAL THE PIPES TO AVOID ANY RUSTING** after cleaning the kit.

CLEAN AND SEAL INSTRUCTIONS:

CLEAN: Recommended supplies: regular degreasing dish soap, washcloths, gloves (optional)
1. Wash your pipes and fittings with warm water and dish soap until the oil is completely removed.
2. Wipe the pipes with a dry washcloth and wait until the pipes are completely dry.

IMPORTANT: THE PIPES MUST BE COMPLETELY DRY BEFORE YOU START THE SEALING PROCESS.

SEAL:

IF USING POLYURETHANE SPRAY: Spray each dry pipe and fitting with a polyurethane matte or satin finishing spray and let it dry before assembling the kit.

IF USING FINISHING WAX: Coat each dry pipe with a finishing wax. Wait for 20 minutes, then polish the pipe with a dry washcloth by wiping them down. Faster wiping will result in a shinier finish.

SPIGOT HANDLE WITH CARTRIDGE HOOK KIT (2-PACK)

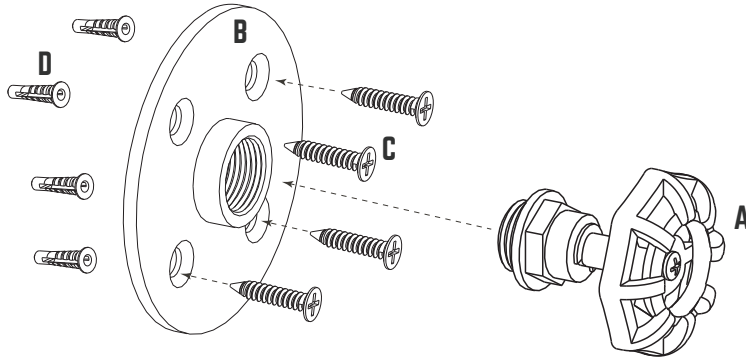

PART	DESCRIPTION	QTY
A	SPIGOT HANDLE WITH CARTRIDGE	2
B	1/2" FLANGE	2
C	SCREWS	8
D	ANCHORS	8

EASY INSTALLATION:

RECOMMENDED TOOLS FOR INSTALLATION

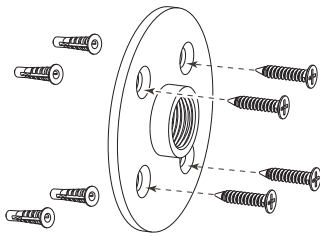
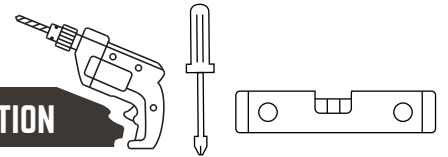

STEP 1

- Place flange against wall in desired location and mark holes with pencil
- Using stud finder, locate and mark wall stud if found
 - A) If a wall stud is present, attach flange to wall with included screws
 - b) If no wall stud is present:
 - Drill pilot holes in wall using 1/4" drill bit
 - Insert anchor fully into pilot hole using hammer and Phillips screwdriver as needed
 - Attach flange to wall using included screws

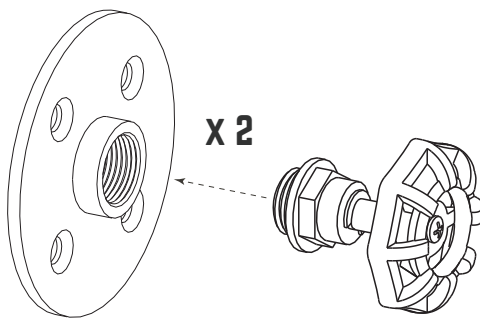

STEP 2

- Screw spigot handle with cartridge into the flange by hand or tighten it with a wrench (optional)