

HAPPINESS HAPPINESS INSTALLATION



CAUTION

Parts are placed at the bottom of the product.

- If you have any questions with the product, please contact us by:
- **Email: customerservice@zoy-living.com**
(we will reply to you within 24 hours)

Assembly Instructions



Model: RD5646A

CAUTION

DO NOT use any sharp objects to open plastic wrapped components as this may result damage to product or components .

Your recliner come packaged in One boxes. Carefully remove all components from the packaging and set them aside for assembly.

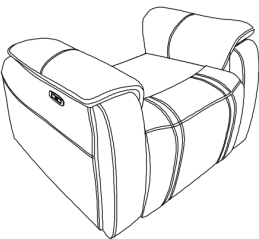
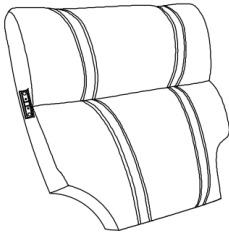
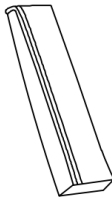
Package Contents

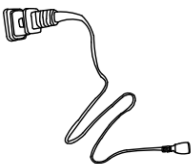
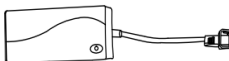
BOX 1 RD5646AF51D				
	A*1	B*1	C*1	D*1
				
	E*1	F*1		

STEP 1 :

Remove the power adapter from the bottom of the seat.

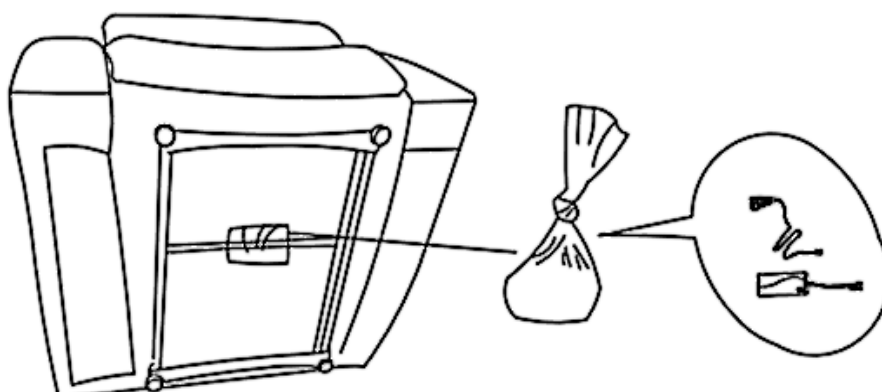

1 RECLINER ASSEMBLY - BODY SETUP

STEP 2 :

Connect the Sofa Back(B) to the Seat(A) by aligning the metal grooves and sliding down to the bottom.

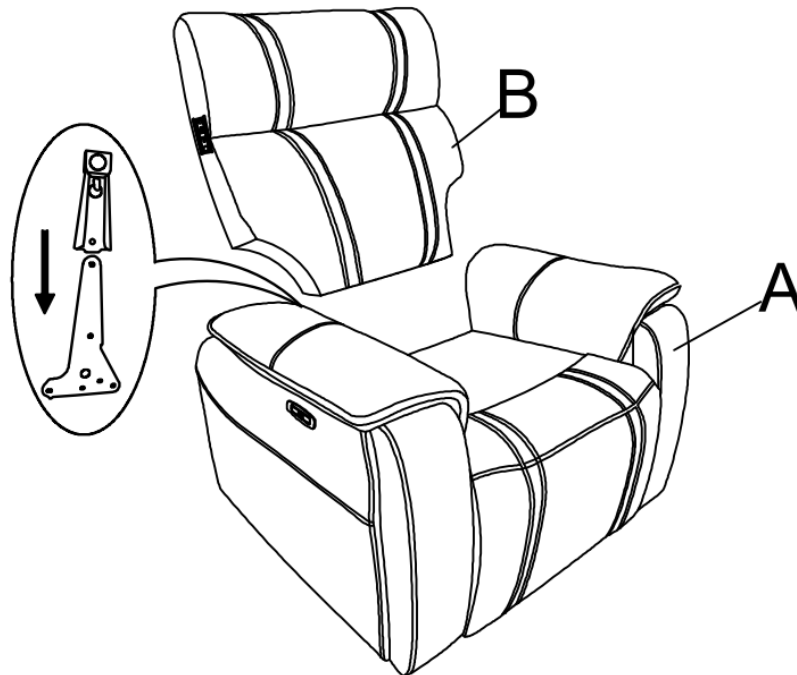

STEP 3 :

Then, install the Ears(C&D) to Sofa Back(B) via aligning the metal slots, make sure it is securely installed before use.

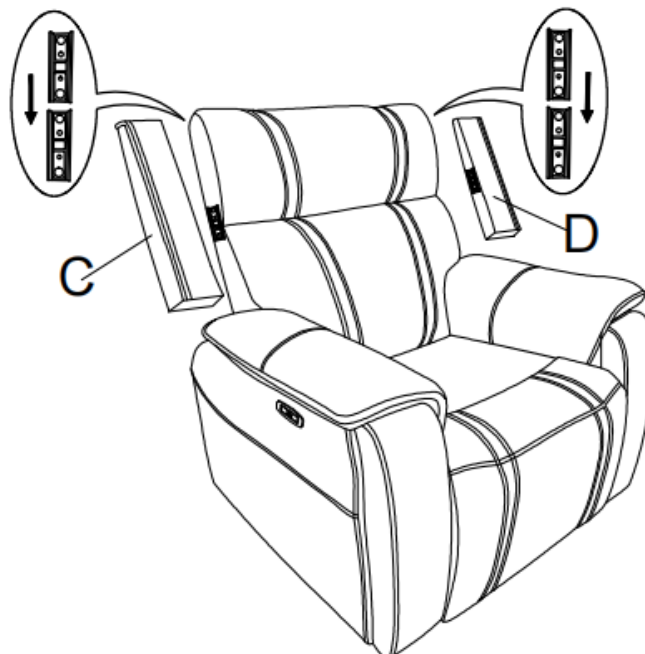

2 RECLINER ASSEMBLY - BODY SETUP

STEP 4 :

Finally, connect the Adapter (F) cable to the connector from the bottom of the Seat Body (A). Then, connect the power adapter (F) and plug (E), then plug it into an outlet. The recliner will then function normally.

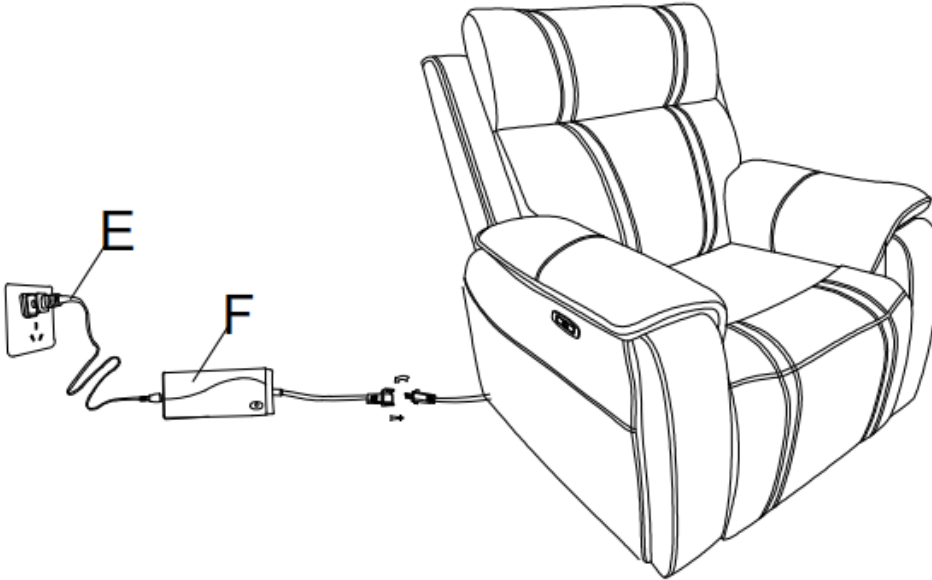

ASSEMBLY COMPLETED

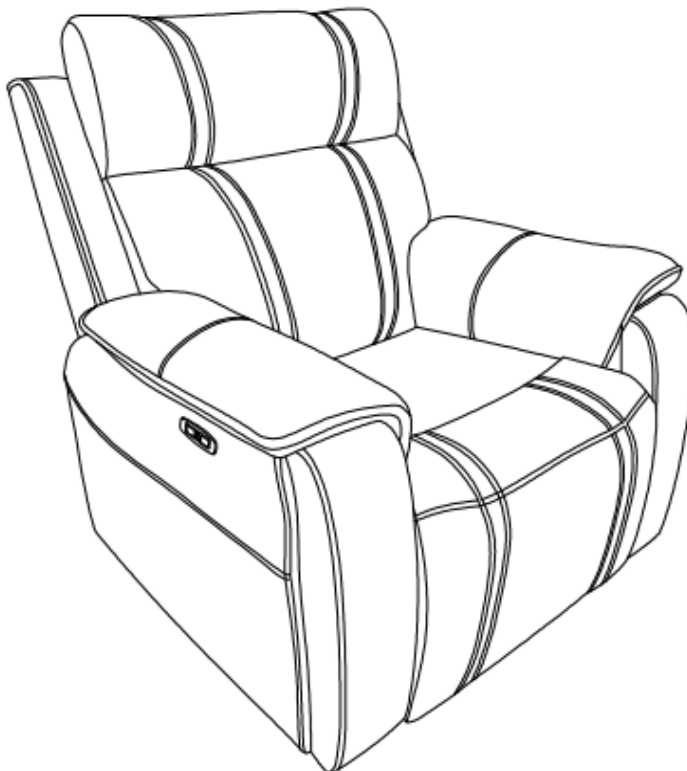

3 RECLINER ASSEMBLY - DIMENSIONS

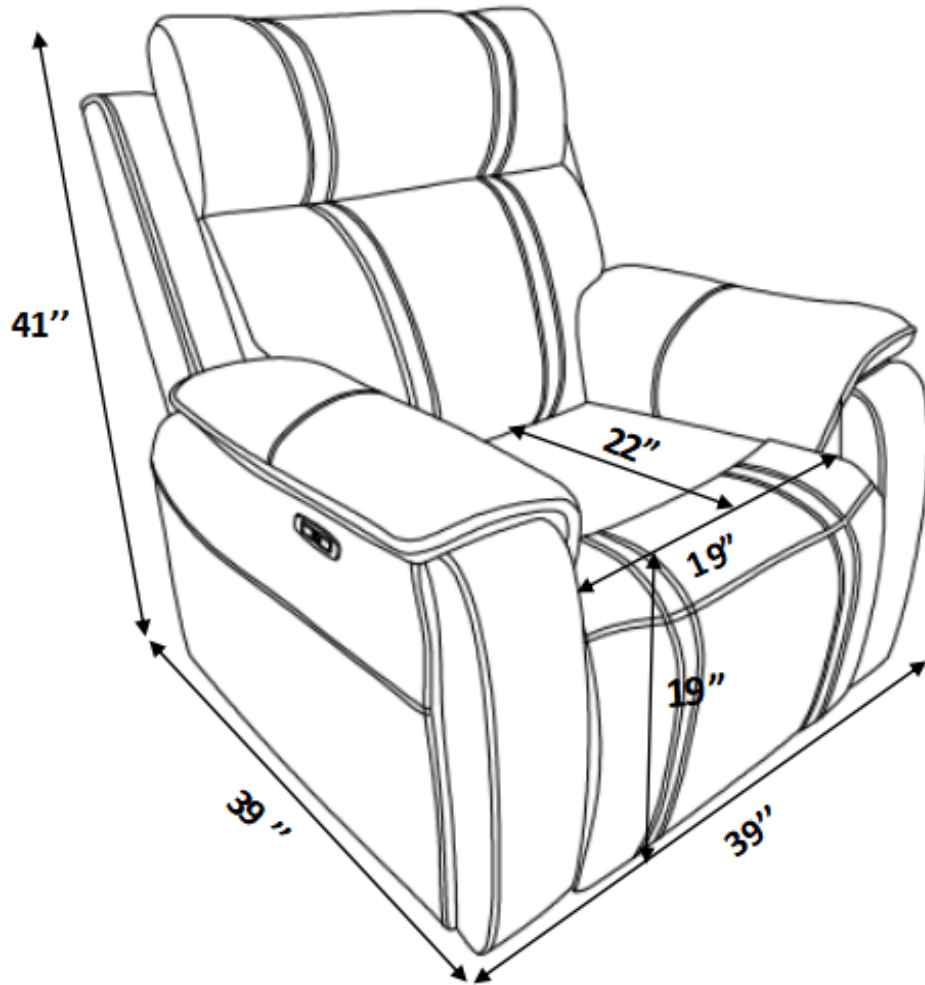

Recliner

RD5646AF51D

⚠️ WARNINGS

1. Please check if the components of the chair are all included and can be used normally.
2. Assemble all components according to the instruction correctly before you connect the chair to the power.
3. Please DO NOT sit on the armrests or footrest to eliminate the risk of tipping over.
4. If the chair is damaged or doesn't match the website description, please send clear pictures of the product and label of the carton to our service team for further help.
5. If the recliner doesn't work, you may try the following measures for self-checking firstly:
 - a) check if all the cables are connected;
 - b) check if the light of transformer is on.

If the chair still doesn't work, please feed the information back to our customer service in time and we will help you solve the matter as soon as possible.

6. If you have any questions about our products, please contact us by:

Email: customerservice@zoy-living.com (we will respond to your inquiry within 24 hours)

