

User Manual

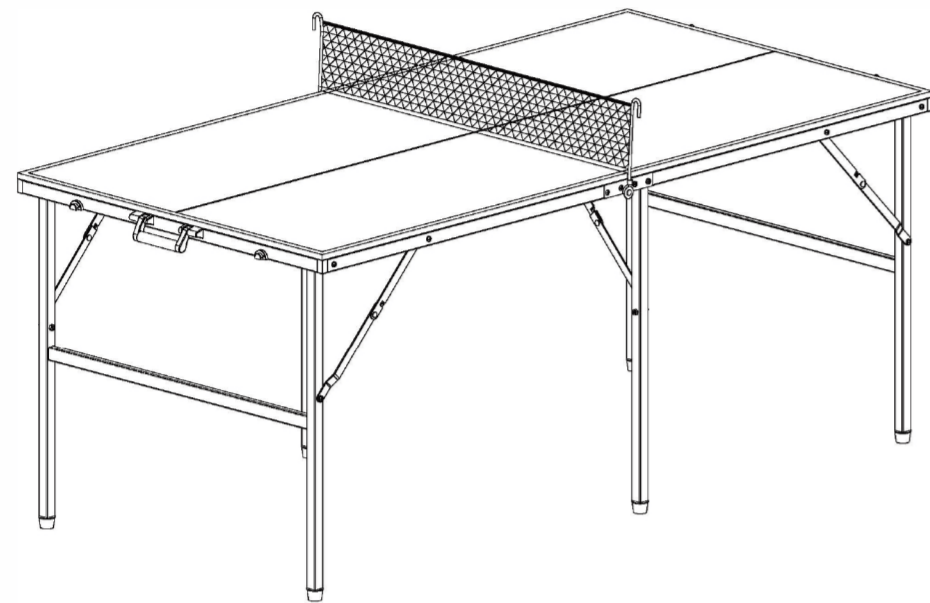

Table Tennis Table

Included

- 1 x Table Tennis Table
- 1 x Game Net
- 1 x Net Rack
- 2 x Paddles
- 3 x Balls
- 1 x User Manual

Product Specifications

Product Name	Table Tennis Table
Materials	MDF, Aluminum
Product Weight	28.63 lbs
Gross Weight	33.04 lbs

Step 1: Open the lock catch of the table tennis table.

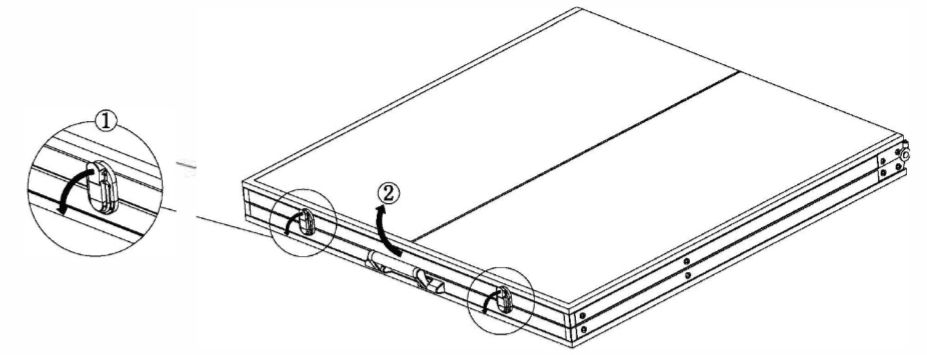

Step 2: Extend the table legs.

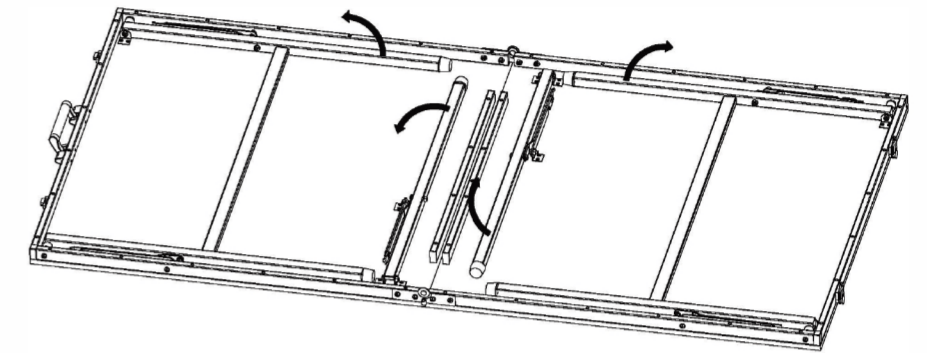

Step 3: Straighten the table legs until they are fully extended.

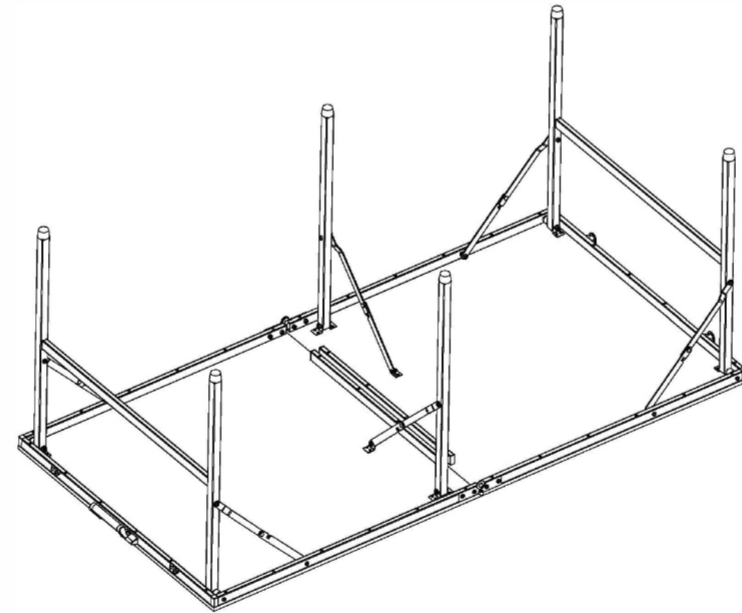

Step 4: Turn the table over (better to handle by two people) and put it on flat ground to ensure stability. Attach the net on the net rack and insert it into the slot on the edge of the table.

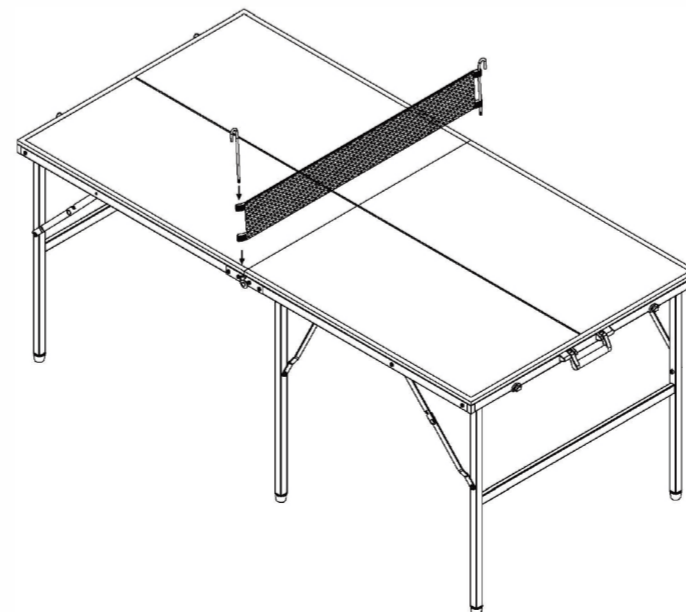

Step 5: Assembly complete! Start your ping pong journey!

