

# Assembly Instructions

Caution: You must read this before you proceed

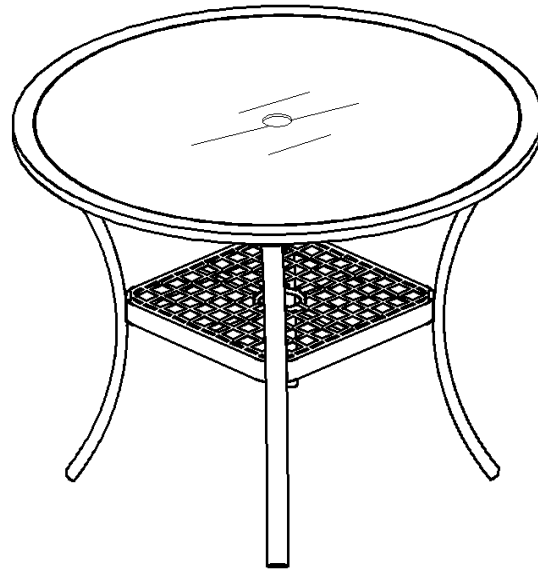

## Table



## Parts List

Label	Picture	Description	QTY
A	A line drawing of a square table top with rounded corners, shown within a circular frame.	Table Top (without glass)	1
B	A line drawing of a single curved table leg.	Table Leg	4
C	A line drawing of a square shelf with a grid pattern and a small circle in the center.	Shelf	1
D	A line drawing of a circular glass top with a small circle in the center and two short lines radiating from it.	Glass	1

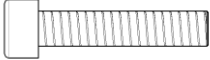
# Hardware

Label	Picture	Description	QTY
E		Allen Key	1
F	 M6*25	Bolt:M6*25mm	9
G		Flat Washer	17
H	 M6*20	Bolt:M6*20mm	9

## Assembly Preparation

Before Beginning Assembly:

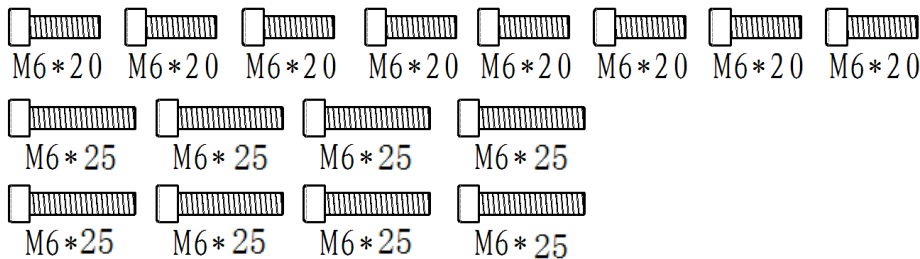
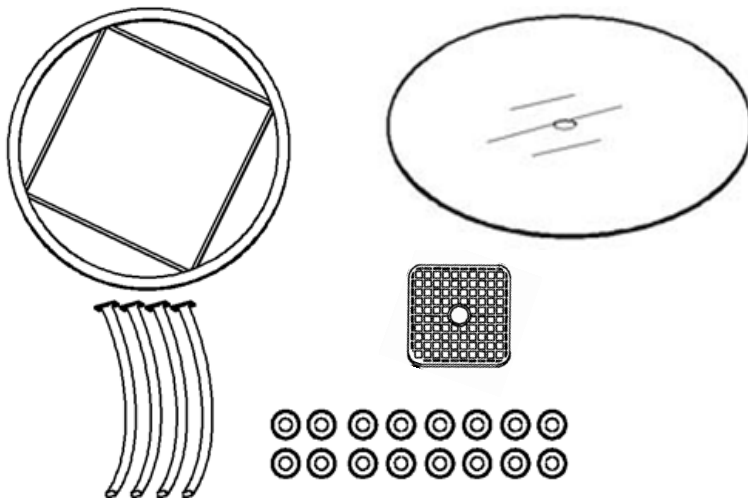

- Read instructions, cover to cover-



- Have 2 adults on hand for assembly-



- Do not assemble on flooring or carpet-



- Assemble on a clean non-marring surface (packing foam)-



- Save all packaging until finished-

# Assembly Steps

## Step 1

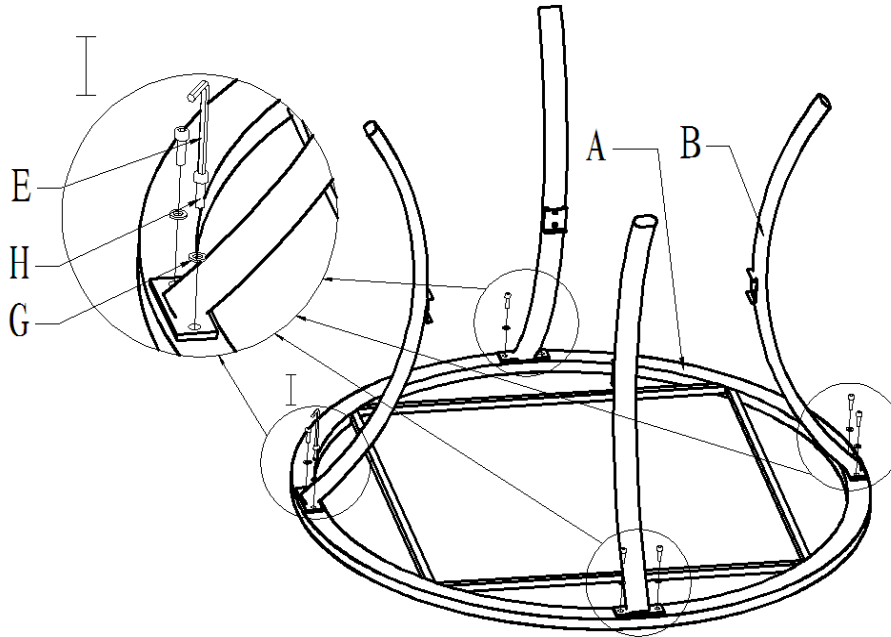

Open the carton and place all the parts onto a clean, non-marring surface.  
Place Table Top(A) face down.

Attach Table Leg(B) to Table Top(A) using Bolt(H)and Flat Washer(G) with Allen Key(E).

Repeat this process with the remaining three Table Legs(B)

**Do not tighten the Bolts.**

**Caution: The Table and its Parts are heavy.**

**A second Adult must assist whenever lifting or moving them.**

## Step 2

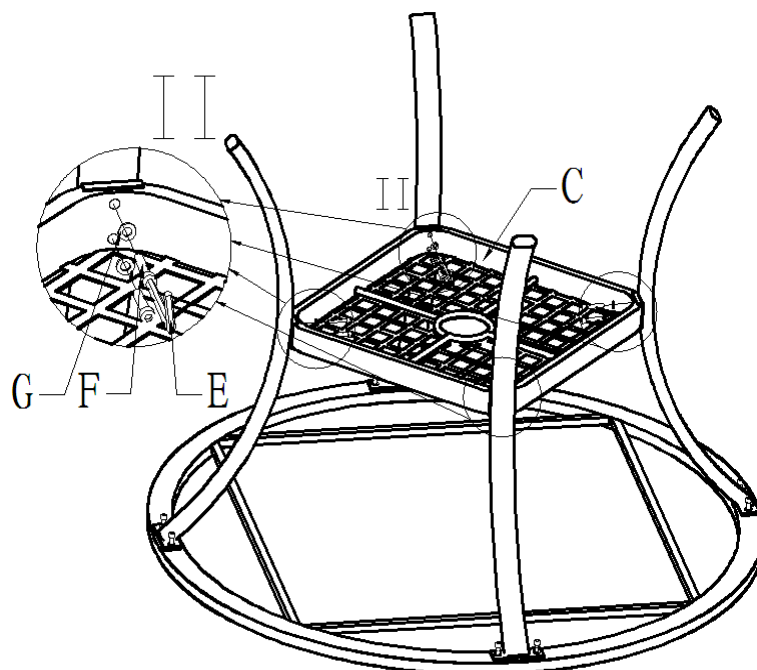

Attach Shelf(C) to Table Legs(B) using Bolt(F) and Flat Washer(G) with Allen Key(E).

**Do not over tighten the Bolts.**

### Step 3

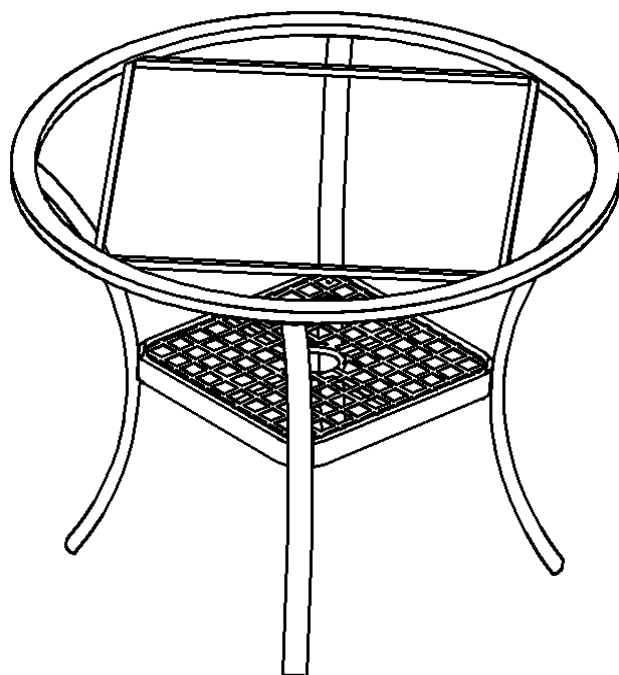





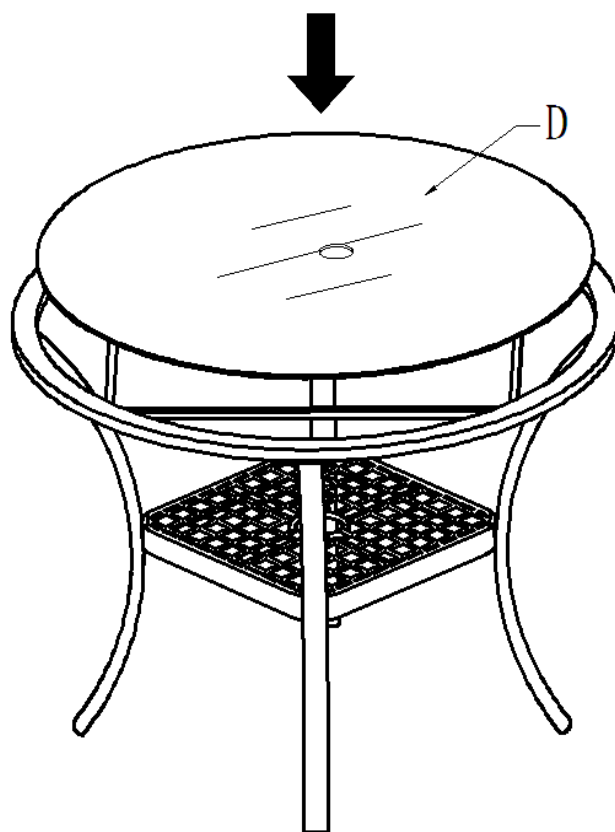





Turn the Table right side up onto a flat surface.  
Assess levelness.  
Then, fully tighten all Bolts at all joints.

### Step 4



Carefully place the Glass(D) onto the Table Top.  
Your Table is ready for use.

## Care & Maintenance

-  Do not put hot items directly on furniture surface
  -  Do not clean furniture with harsh cleansers or polish.
  -  To obtain the longest lifespan of your outdoor products, minimizing exposure to direct sunlight is recommended.
  -  Children should not climb or jump on the furniture.
  -  Do not write on furniture without a padded barrier to protect the surface.
  -  To obtain the longest lifespan of your outdoor products, avoid extended and lengthy exposure to rain, snow, and direct sunshine. Whenever possible cover the product and /or place under patio or awnings.
  -  Not for commercial use. For residential use only .
  -  Stains may be removed with mild soap solution and damp cloth.
  -  Keep away from sources of ignition.
- 
-  Dust and pick-up spills using a clean, non-colored, lint-free cloth .