

AIRMSEN

DUAL BREW COFFEE MAKER



USER MANUAL

If you are having problems using this dual brew coffee maker
Please email : service@airmsen.com or call 1-844-725-2333
for assistance : www.airmsen.com

To best serve you, our AIRMSEN Representatives are available to answer your calls Monday to
Friday, 10:30 AM - 6:30 PM EST.

THANK YOU FOR MAKING AIRMSEN APPLIANCES A PART OF YOUR HOME.

CONSTANT INNOVATION FOR BETTER PRODUCTS

With “technology, innovation, health” as our core value, we strive to provide you with the preferred brand of household products in your healthy and quality life.

AIRMOSEN focuses on researching, developing and manufacturing various kinds of household supplies with advanced technologies and the idea of sustainable development. Aiming to promote the evolution of our lifestyle, we will bring our customers around the world a healthier, happier, more intelligent and ecofriendly home life with our high quality products.

SAFETY

Your safety and the safety of others is very important.

We have provided many important safety messages in this manual and on your appliance. Always read and obey all safety messages.



This is the safety alert symbol.

This symbol alerts you to potential hazards that can cause serious injury to you and others.

All safety messages will follow the safety alert symbol.

All safety messages will tell you what the potential hazard is, tell you how to reduce the chance of injury, and tell you what can happen if the instructions are not followed.

CONTENTS

IMPORTANT SAFEGUARDES	04
-----	-----
COMPONENT INTRODUCTION	06
-----	-----
CONTROL PANEL	07
-----	-----
OPERATION	09
HOW TO BREW A CARAFE	09
HOW TO BREW A SINGLE-SERVE POD	10
HOW TO BREW SINGLE-SERVE GROUND COFFEE	11
SCHEDULED BREW	12
-----	-----
CLEANING AND MAINTENANCE	13
DESCALING	13
-----	-----
TROUBLESHOOTING	14
-----	-----
WARRANTY	16
-----	-----
CUSTOMER SUPPORT	17

PRODUCT PARAMETERS

Power voltage	Rated current	Power	Dimensions	Water tank capacity	
				Capacity (Carafe)	Capacity (Single Serve)
120V~60Hz	8.3A	1000W	13.58x9.33x13.52in. (34.5x23.7x34.3cm)	1.8L / 60Oz (max. 12cups)	14Oz / 410ml

IMPORTANT SAFETY MEASURES

Congratulations on your purchase of the new Airmsen coffee machine. This user manual contains important information regarding the installation, use, and maintenance of this machine. Please spend some time reading this manual to make the best use of all functions of this coffee machine.

SAFETY INSTRUCTIONS

To reduce the risk of fire, electric shock, and/or personal injury, please always stick to the following basic safety precautions when using this machine:

1. Read all instructions before use.
2. This appliance is for **HOUSEHOLD USE ONLY**.
3. **WARNING** –to protect against electric shock, fire and personal injury:
 - do not immerse cord, plug or appliance in water or other liquids;
 - do not immerse the appliance or any electrical components in water or any other liquids;
 - always switch off and unplug the appliance before cleaning.
4. Close supervision is necessary when any appliance is used by or near children.
5. This appliance can be used by children aged from 8 years and above and persons with reduced physical, sensory or mental capabilities or lack of experience and knowledge if they have been given supervision or instruction concerning use of the appliance in a safe way and understand the hazards involved.
6. Unplug from wall outlet when the appliance is not in use, before putting on or taking off parts, and before cleaning.
7. Allow to cool before handling putting on or taking off parts, and before cleaning the appliance.
8. Do not operate any appliance with a damaged cord or plug, or after the appliance malfunctions or has been damaged in any manner.
9. Do not use outdoors or in a damp area.
10. Do not place the appliance close to the edge of the countertop.
11. Do not let power cord hang over edge of table or counter, or touch hot surfaces.
12. Do not place on or near a hot gas or electric burner or in a heated oven. To switch off and disconnect, press the **ON/OFF**  Button, then remove plug from wall outlet.
13. Do not use appliance for other than intended use. The Carafe is designed for use with this appliance only. It must never be used on a range top.
14. Do not set a hot Carafe on a wet or cold surface.
15. Do not leave an empty Carafe on the Keep Warm Plate while the appliance is switched on. This may cause the Carafe to crack.
16. Do not use a cracked Carafe or a Carafe having a loose or weakened handle.
17. Do not clean the Carafe with cleansers, steel wool pads, or other abrasive material.
18. Discard the Carafe if cracked, scratched, boiled dry or heated when empty.
19. Scalding may occur if the Lid is opened during the brewing cycles. When opening

the Lid after use, be careful as hot steam can be trapped beneath. Steam can burn.

20. Do not touch the Keep Warm Plate while the appliance is switched on.
21. Do not operate the appliance with an empty Water Reservoir.
22. Do not clean with metal scouring pads. Pieces can break off the pad and touch electrical parts involving a risk of electric shock.
23. Never leave the appliance unattended during operation.
24. A fire may occur if the appliance is covered or touching flammable material, including curtains, draperies, walls, and the like, when in operation. Do not store any item on top of the appliance when in use.
25. Extreme caution must be used when moving an appliance containing liquids.
26. Do not open the Lid, add water immediately after brewing, or remove the Brew Basket during or immediately after use. Always exercise caution when opening the Lid or removing the Brew Basket after use. Hot steam might be trapped beneath. Scalding may occur if the Lid is opened during the brewing cycle.
- 27. Do not open the release lever, lid or remove the coffee grounds/capsule container during or after use. Be careful when opening the lid or removing the coffee grounds/capsule container after use. Hot steam may be trapped under the lid. If the lid is opened during brewing, it may cause burns.**
28. Do not use the appliance with an empty or under filled Brewer Water Reservoir. Do not fill the Brewer Water Reservoir over the **12 MAX** marking.
29. Keep the area above the appliance clear during use, as hot steam will escape the appliance.
30. Do not use the appliance without the Carafe placed under the Pause and Serve Valve.
- 31. Do not use the appliance without the Brew Basket/paper filter.**
- 32. Do not use this product without a coffee powder box or coffee capsule box installed.**
33. Do not use hot water, milk or other liquids for brewing.
34. Use extreme caution when removing the Ground Coffee Holder/Capsule Holder and disposing of used coffee ground/capsules.
35. Only use capsules intended for this appliance. If the capsule does not fit, do not force the capsule into the appliance.
- 36. CAUTION! Risk of injury. Replace the Carafe within 30 seconds while brewing.**
- 37. This product is for K-Cup capsules only, do not force other capsules into the device.**
- 38. CAUTION! Potential Injury! There is a sharp needle on the top of the single cup cover, please be careful when handling and cleaning. Do not touch the needle.**
- 39. CAUTION!** Do not open the Brewer Lid, Water Reservoir Lid and Single Serve Lid during brewing, or immediately after brewing. Hot water and steam may cause scalding.
- 40. DO NOT** leave used coffee capsules in the Capsule Holder. **DO NOT** leave used coffee grounds in the Ground Coffee Holder, Brew Basket/paper filter.

COMPONENT INTRODUCTION

Describe

1. Shower Head
2. 60Oz Water Tank
3. Filtering Chamber
4. Water Ruler
5. Warming Plate
6. 14oz Water Tank
7. Release lever
8. Piercing Needle
9. Filtering Chamber
10. Control Panel
11. Removable Cup Rest / Storage Container

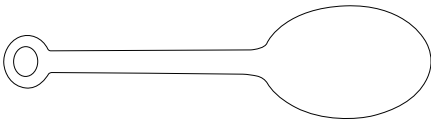
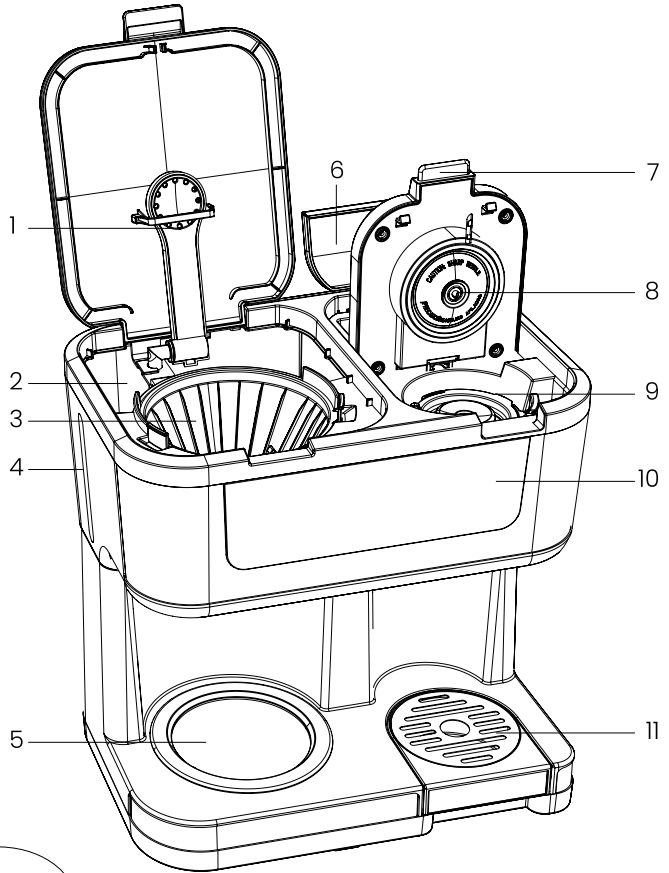

Coffee powder scoop (5g capacity)

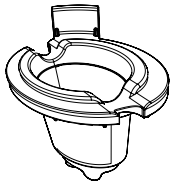

Capsule box

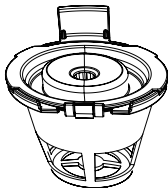

Powder box

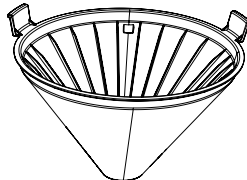

Coffee powder funnel

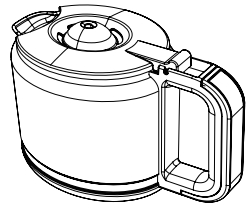

Carafe

To order parts, visit: www.airmsen.com.

CONTROL PANEL

Introduction to Control Panel Functions and Operations.



PROG 1. SETTING THE TIMER:

- Tap the “**PROG**” button to activate the scheduling function. The time display will begin flashing.
- Tap the “**HOUR**” button to set the desired hour, then tap the “**MIN**” button to set the minutes.
- “**AM**” indicates morning hours, while “**PM**” indicates afternoon/ evening hours.

HOUR 2. HOUR: Tap the “**HOUR**” button to adjust the current time or scheduled timer. Each press increases the hour by 1.

AM PM 12:00 3. TIME DISPLAY:

- The current time is always displayed (in standby or operation mode).
- If power is lost, the clock will reset to the default time.
- To set a custom time: Press the “**HOUR**” and “**MIN**” buttons to adjust.
- “**AM**” indicates morning hours, while “**PM**” indicates afternoon/ evening hours.

MIN 4. MIN: Tap the “**MIN**” button to adjust the current time or scheduled timer. Each press increases the time by 1 minute.

- ### GROUND 5. GROUND: Press the “**GROUND**” button to turn on the device. The icon will stay lit during operation.

Note: If the icon keeps flashing, the cover is not properly closed.

- ### CAPSULE 6. CAPSULE: Press the “**CAPSULE**” button to turn on the device. The icon will stay lit during operation.

Note: If the icon keeps flashing, the cover is not properly closed.

CLEAN 7. CLEAN: When the “**CLEAN**” flashes, Your machine has completed 250 operating cycles and requires maintenance.

- Refill the water tank with clean water. Perform pipe cleaning.
- **Refer to Page 18:** Descaling Procedure.

1-4 8. **1-4 CUP BREW FUNCTION:**

- Press the “1-4  ” button (icon will stay lit).
- Press the “**BREW**” button (icon will stay lit) to start brewing.

NOTE: This mode does not include keep-warm function.

9. **POWER SWITCH BUTTON:**

- Single press during operation, Cancels current function and puts the device into standby mode.
- Press and hold for 2 seconds: Powers off the device. Only the time display and power switch remain lit, All other icon turn off.

BREW 10. **BREW:**

1. **Full Pot BREW (12 cups):**

- Press “**BREW**” (icon stays lit) to start 12-cup brewing cycle. During brewing, Icon remains lit.

NOTE: After brewing, Auto keep-warm function activates (2 hours)Icon turns off when cycle completes.

2. **Small Batch 1-4 :**

- Press “1-4  ” (icon lights up), Then press “**BREW**” to start.

NOTE: No keep-warm function in this mode.

3. **Scheduled Full-Pot BREW (12 Cups):**

- Press “**PROG**” (clock starts flashing).
- Set time using “**HOUR**” and “**MIN**” buttons.
- “**AM**” indicates morning hours, while “**PM**” indicates afternoon/evening hours.
- Press “**AUTO**” (icon stays lit, indicating scheduled brewing is set).
- At scheduled time: 12-cup brew starts automatically.

NOTE: After brewing, Auto keep-warm function activates (2 hours)Icon turns off when cycle completes.

4. **Scheduled Small Batch 1-4 :**

- Press “**PROG**” (clock starts flashing).
- Set time using “**HOUR**” and “**MIN**” buttons.
- “**AM**” indicates morning hours, while “**PM**” indicates afternoon/evening hours.
- Press “1-4  ” (icon lights up).
- Then press “**AUTO**” (icon stays lit, indicating scheduled brewing is set).

NOTE: No keep-warm function in this mode.

AUTO 11. **AUTO: After setting your desired brew time with “PROG”, “HOUR” and “MIN” buttons.**

- Press “**AUTO**” to lock in your scheduled time. The button indicator lights up to indicate that the operation is in progress.
- Press and hold “**AUTO**” for 2 seconds to cancel scheduled brew. Button light turns off.

OPERATION

HOW TO BREW A CARAFE

This appliance can be used for brewing up to 12 cups coffee using ground coffee and keeping coffee warm up to 2 hours or for brewing up to 4 cups coffee using ground coffee for consumption shortly after operation, according to the **PROGRAM** selected.

The steps are as follows:

- 1. Power On:** Plug the machine into a power outlet.
- 2. Prepare Brew Basket:** Lift the lid and remove the brew basket.
- 3. Insert Filter:** Place a basket-style paper filter into the brew basket.
- 4. Add Coffee Grounds:**
 - Use 1 tablespoon (5g) of coffee per cup.
 - Maximum capacity: 60g (for 12 cups).
- 5. Fill water:** Pour cold water into the water tank, max. 12 cups (use a carafe as a measure).
- 6. Assemble Components:** Insert the brew basket into its holder. Close the lid securely.
- 7. Position Carafe:** Place the carafe (with lid on) onto the warming plate.

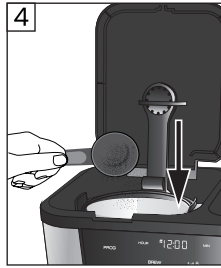
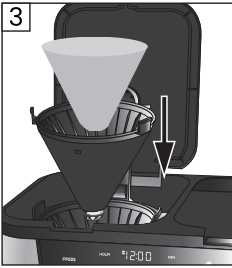

- 8. Start Brewing:** Press the **"BREW"** button, The icon lights up to indicate brewing is in progress.
- 9. Keep-Warm Function:**
 - Automatically keeps coffee warm for 2 hours.
 - Icon turns off when cycle completes.
 - 1-4 ☕ No keep-warm function in this mode.
- 10. Cleaning After Use:** Always rinse both the brew basket and carafe after each use.

⚠ NOTE:

- Unit will only brew on one side at a time.
- The Brew Basket/Paper filter is hot after using the appliance.
- Do not touch the Keep Warm Plate after use and for some time, as it remains hot.
- The coffee pot must be replaced within 20 seconds of being removed to prevent spillage.
- If you buy pre-ground coffee, choose packages with the most recent expiration date or a smaller quantity.
- For better tasting coffee: Use filtered/bottled water instead of tap water.
- Excessively fine grounds may cause basket overflow.

HOW TO BREW A SINGLE-SERVE POD

1. Fill Water Tank:

- Open the single-serve water tank lid.
- Add water between MIN (minimum) line [6 oz/180 ml] and MAX (maximum) line [14 oz/410 ml].
- Close lid securely

2. Press the release lever to open the lid.

3. Place the removable capsule holder into the funnel.

4. Place capsule into holder (do not remove aluminum foil).

5. Press lid down until it clicks into place (this pierces the capsule).

6. Plug in the machine.

7. Press “ CAPSULE” button, The icon lights up to indicate brewing is in progress.

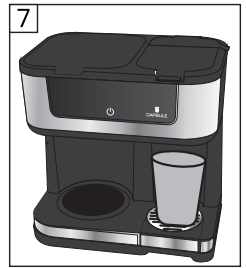
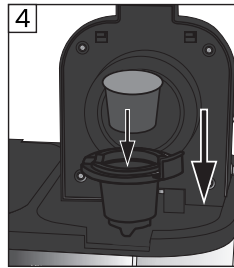
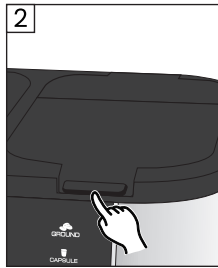
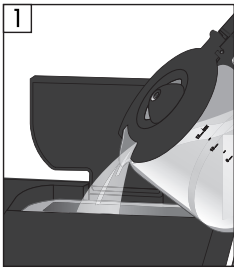

8. Machine will turn off automatically after brewing completes.

9. Always rinse the capsule holder after each use.



WARNING

- If overflow occurs: Immediately unplug the machine, Allow to cool completely before handling.
- Never lift the lid during brewing.
- Use a cup sized appropriately for your brew (min. 6 oz / 180 ml).

CUT HAZARD WARNING

- Removable single-serve pod holder has a sharp needle. Piercing needle on underside of lid is also sharp. Use caution when handling.

NOTE

- Cold water only in tank (no hot water/creamer/other liquids).
- Never reheat coffee in the machine.
- If “ GROUND ” + “ CAPSULE ” icons flash: Close lid firmly until click is heard.
- Never brew if needle holder isn't fully locked.

HOW TO BREW SINGLE-SERVE GROUND COFFEE

1. Fill Water Tank:

- Open the single-serve water tank lid.
- Add water between MIN (minimum) line [6 oz/180 ml] and MAX (maximum) line [14 oz/410 ml].
- Close lid securely

2. Press the release lever to open the lid.

3. Open the brew basket lid and place the removable basket on a flat surface.

4. Fill with ground coffee, Close the brew basket lid firmly.

5. Insert the brew basket into the funnel.

6. Close and lock the main lid until it clicks into place.

7. Plug in the machine.

8. Press " " button, The icon lights up to indicate brewing is in progress.

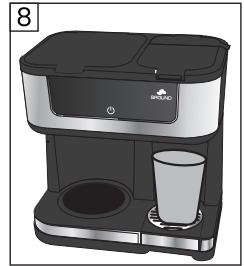
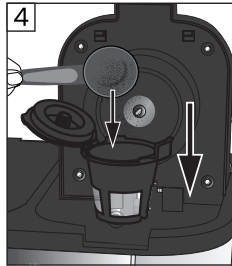
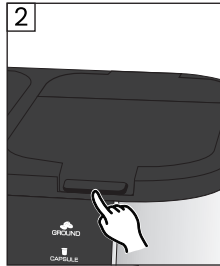
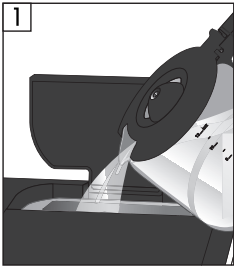

9. Machine will turn off automatically after brewing completes.

10. Always rinse the brew basket after each use.



WARNING

- If overflow occurs: Immediately unplug the machine, Allow to cool completely before handling.
- Never lift the lid during brewing.
- Use a cup sized appropriately for your brew (min. 6 oz / 180 ml).

CUT HAZARD WARNING

- Removable single-serve pod holder has a sharp needle. Piercing needle on underside of lid is also sharp. Use caution when handling.

NOTE

- Cold water only in tank (no hot water/creamer/other liquids).
- Never reheat coffee in the machine.
- If you use finer ground coffee, coffee will continue to drip after the indicator light goes out.
- Touch the "**POWER**" icon during brewing to stop the brewing process
- If coffee has sediment: Add a #1 cone-shaped paper filter to the brew basket
- If "  " + "  " icons flash: Close lid firmly until click is heard.
- Never brew if needle holder isn't fully locked.

SCHEDULED BREW

NOTE: Unit will only brew on one side at a time. Single-serve side cannot be used while Carafe side is programmed.

Scheduled BREW (12-Cup Carafe):

1. Set Current Time:

- Press **"HOUR"** to set correct hour, **"AM"** indicates morning hours, while **"PM"** indicates afternoon/evening hours.
- Press **"MIN"** to set minutes.

2. Program Scheduled Brew:



1. Press **"PROG"** (clock display will flash).
 2. Set brewing time.
- Press **"HOUR"** for desired hour, Press **"MIN"** for desired minutes.
3. Confirm by pressing **"AUTO"**.
- Illuminated **"AUTO"** icon indicates scheduled brew is set.

Scheduled 1-4 :

1. Set Current Time:

- Press **"HOUR"** to set correct hour, **"AM"** indicates morning hours, while **"PM"** indicates afternoon/evening hours.
- Press **"MIN"** to set minutes.

2. Program Scheduled Brew:

1. Press **"PROG"** (clock display will flash).
 2. Set brewing time.
- Press **"HOUR"** for desired hour, Press **"MIN"** for desired minutes.
3. Press **1-4 ** (icon lights up).
 4. Confirm by pressing **"AUTO"**.
- The **1-4 ** and **"AUTO"** icons light up, indicating that the 1-4 scheduled brewing times have been successfully set.

Helpful Tips:

- To check scheduled time: Press **"PROG"** - your set time will display.
- You can repeat the above steps to change the scheduled brewing time. Press the scheduled brewing **"AUTO"** icon to restart the scheduled brewing and the indicator light will light up.
- Press and hold **"AUTO"** for 2 seconds to cancel scheduled brew. Button light turns off.

CLEANING AND MAINTENANCE

⚠ WARNING

- Always disconnect the Plug from the wall outlet before cleaning. Allow all parts of the appliance to cool down completely.
- The underside of the Single Serve Lid and the Capsule Holder both contain sharp needles. Use caution when handling and during cleaning. Do not touch the needles.

NOTE

- Do not immerse the power cord with Plug and appliance into water or any other liquids.
- Do not use abrasive cleaners, steel wool or scouring pads. Dry all parts thoroughly after cleaning, before using or storing the appliance. Ensure that no water enters the appliance.
- Remove the Drip Tray with Cup Holder, Ground Coffee Holder, Capsule Holder and Brew Basket from the appliance. These parts can be washed in hot soapy water.
- Wipe the seal on the needle on the underside of the Lid with a damp cloth. Do not attempt to remove the seal.
- Clean the appliance and Keep Warm Plate with a clean, slightly damp cloth.
- Clean the Carafe, Brew Basket in hot, soapy water.

DESCALING

Your coffee machine features a brew cycle counter:

After 250 brew cycles (carafe or single-serve side), the corresponding **"CLEAN"** button will blink. Machine remains operational, but flow rate may slow due to scale buildup.

For the brewer side:

1. Use household descaling agent or white vinegar (2:1 ratio of water to vinegar).
2. Fill the water tank on the side of the coffee pot with water and add descaling agent up to the 12-cup MAX mark.
3. Place the empty coffee pot on the warming plate and press the left **"CLEAN"** button (it will light up to start the program).
4. When the coffee machine is finished, it will switch to standby mode and pour out the solution in the coffee pot. Brew the device with clean water at least 3 times. After each rinse, pour out the water.

For the Single Serve side:

1. Fill the single-cup water reservoir up to the 14 oz (410 ml) mark.
2. Use household descaling agent or white vinegar (2:1 ratio of water to vinegar).
3. Place a large mug or cup (at least 16 oz) in the cup holder.
4. Press the **"CLEAN"** button (it will light up to start the program).
5. When the coffee machine has finished brewing, it will enter standby mode and pour out the solution in the cup.
6. Brew the coffee machine at least 3 times with clean water. After each rinse, pour out the water.

TROUBLESHOOTING

Q1: THE APPLIANCE IS NOT WORKING.

1. Brewing cycle not started.
2. Malfunctioning appliance.

REMEDY

1. Press the relevant Button according to the Operation section.
2. Unplug the appliance from the wall outlet and contact qualified personnel to check and repair the appliance.

Q2: THE WATER SUPPLY VALVE DOES NOT DISCHARGE WATER.

1. Brewer Water Reservoir is empty.
2. The Brew Basket is blocked.
3. Wrong carafe used.

REMEDY

1. Filling the coffee machine water tank Reservoir.
2. Clean the Brew Basket.
3. Always use the GlassCarafe provided with the appliance.

Q3: NO WATER COMES OUT OF THE NOZZLE.

1. Nozzle blocked.
2. Water Reservoir is empty.
3. Capsule not suitable.
4. Upper/bottom of the capsule not pierced by the needle.

REMEDY

1. Check the Nozzle for blockages.
2. Refill water into the Water Reservoir.
3. Replace with a suitable capsule.
4. Switch the appliance off and carefully replace the capsule.

Q4: BREWING PROCESS STOPS BEFORE COMPLETION.

1. Single Serve Lid opened or not locked in place before/during brewing process.
2. Not enough water according to the volume pre-selected.

REMEDY

1. Close the Single Serve Lid to lock it and press the respective Button again.
2. Refill the water reservoir with fresh water to the water reservoir and restart operation.

Q5: THE COFFEE IS TOO STRONG.

Too much ground coffee in the Ground Coffee Holder/paper filter.

REMEDY

Reduce the amount of ground coffee used.

Q5: PAUSE AND SERVE VALVE IS LEAKING WHEN CARAFE REMOVED.

Coffee powder residue stuck around the seal of the Pause and Serve Valve.

REMEDY

Wash the Brew Basket thoroughly, paying special attention to the area around the Pause and Serve Valve.

Q6: THE COFFEE IS TOO WEAK.

1. Ground coffee too coarse.
2. Not enough ground coffee used.
3. Capsule used more than once.
4. Too much water used.

REMEDY

1. Try a finer ground coffee.
2. Use more ground coffee for your next brew.
3. Discard of the old capsule and use a new one.
4. Reduce the amount of water used on the next brew.

Q7: INCREASED BREW CYCLE TIME/SLOWED BREW OUTPUT.

Mineral scale build-up in the water system.

REMEDY

Descal the appliance following instructions from the Descaling section.

WARRANTY

Product Name	Model Number	Default Warranty Period	Date of Purchase	For your own reference, we strongly recommend that you record your order number and date of purchase.
DUAL BREW COFFEE MAKER	HR-CM307U	2 years		

TERMS & POLICY

AIRMOSEN warrants all products to be of the highest quality in material, craftsmanship, and service, effective from the date of purchase to the end of the warranty period.

AIRMOSEN will replace any product found to be defective due to manufacturer flaws based on eligibility. Refunds are available within the first 30 days of purchase. Refunds are only available to the original purchaser of the product. This warranty extends only to personal use and does not extend to any product that has been used for commercial, rental, or any other use in which the product is not intended for. There are no warranties other than the warranties expressly set forth with each product.

This warranty is non-transferrable. AIRMOSEN is not responsible in any way for any damages, losses, or inconveniences caused by equipment failure by user negligence, abuse, or use noncompliant with the user manual or any additional safety or usage warnings included in the product packaging and manual.

THIS WARRANTY DOES NOT APPLY TO THE FOLLOWING:

- Damage due to abuse, accident, alteration, misuse, tampering, or vandalism.
- Improper or inadequate maintenance.
- Damage in return transit.
- Unsupervised use by children under 18 years of age.

AIRMOSEN assume no liability for damage caused by the use of the product other than for its intended use or as instructed in the user manual. Some states do not allow this exclusion or limitation of incidental or consequential losses, so the foregoing disclaimer may not apply to you. This warranty gives you specific legal rights and you may also have other rights, which may vary from state to state.

ALL EXPRESSED AND IMPLIED WARRANTIES, INCLUDING THE WARRANTY OF MERCHANTABILITY, ARE LIMITED TO THE PERIOD OF THE LIMITED WARRANTY.

DEFECTIVE PRODUCTS & RETURNS

Should your product prove defective within the specified warranty period, please contact Customer Support via service@airmsen.com with your order number. DO not dispose of your product before contacting us. Once our Customer Support Team has approved your request, please return the unit with a copy of your invoice and order number.

CUSTOMER SUPPORT

WE'RE HERE TO HELP!

If you encounter any issues or have any questions regarding your new product, please contact our helpful Customer Support Team. Your satisfaction is our goal!

CUSTOMER SUPPORT

Email: service@airmsen.com

Telephone: **1-844-725-2333**

*** To best serve you, our AIRMSEN Representatives are available to answer your calls Monday to Friday, 10:30 AM – 6:30 PM EST.**

If you need to purchase product accessories, please visit www.airmsen.com.

* Please have your order confirmation number ready before contacting Customer Support.



<https://www.facebook.com/Airmsen>



<https://www.youtube.com/@AIRMSEN>

For product operation videos, please subscribe to AIRMSEN's official Youtube account.

AIRMSSEN

QUESTIONS OR COMMENTS?

EMAIL	OR VISIT US ONLINE AT
service@airmsen.com	www.airmsen.com

