

ASSEMBLY INSTRUCTIONS / INSTRUCTIONS DE MONTAGE
TWIN BUNKBED WITH 4 BOOKSHELFS / LIT DOUBLE SUPERPOSÉ AVEC 4 ÉTAGÈRES

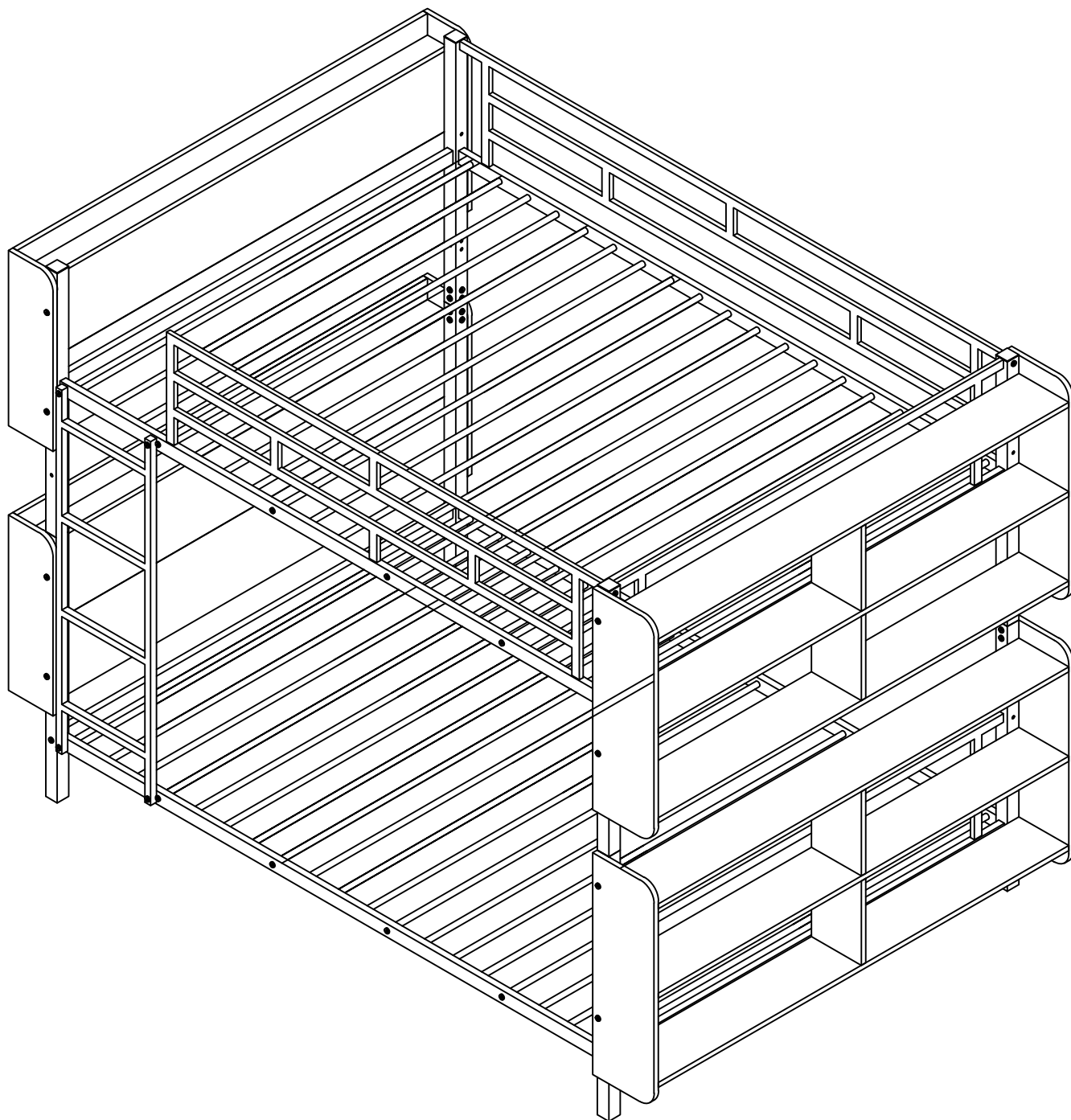



SAFETY WARNING



1. This bed is designed for use only mattress (es) meeting the following specifications on the upper bunk, and lower bunk: bunk, and lower bunk

Upper Bunk

Bed type

Twin Standard

Length

74"-75"

Width

38"-39"

6"

Lower Bunk

Bed type

Twin Standard

Length

74"-75"

Width

38"-39"

6"

2. Replacement parts, including additional guardrails, maybe obtained from any of our (GIGACLOUD TECHNOLOGY (USA) INC 4388 Shirley Avenue El Monte, CA 91731) dealers
3. Follow the information on the warnings appearing on the upper bunk bed end structure and on the carton. Do not remove warning label from bed.
4. Always use the recommended size mattresses or mattress supports, or both, to help prevent the likelihood of entrapment or falls.
5. Surface of mattress must be at least 5" (127mm) below the upper edge of guardrails.
6. Do not allow children under 6 years of age to use the upper bunk.
7. Periodically check and ensure that the guardrail, ladder, and other components are in their
8. Do not allow horseplay on or under the bed and prohibit jumping on the bed.
9. Always use the ladder for entering and leaving the upper bunk.
10. Do not use substitute part. Contact the manufacture or dealer for replacement part./
11. Use of a night light may provide added safety precaution for a child using the upper bunk.
12. Always use guardrails on both long sides of the upper bunk. If the bunk bed will be placed next to the wall, the guardrail that runs the full length of the bed should be placed against the wall to prevent entrapment between the bed and wall.
13. The use of water or sleep flotation mattresses is prohibited.
14. STRANGULATION HAZARD - Never attach or hang items to any part of the bunk bed that are not designed for use with the bed; for example, but not limited to, hook, belts and jump ropes.
15. Keep these instruction for future reference.
16. Prohibit more than one person on upper bunk
17. We recommend assembling your bunk bed on the shipping carton to protect your floor or carpetre tapis.
18. Be certain all staples are out of the box before beginning assembly on the shipping carton.



ALERTE DE SÉCURITÉ



1. Ce lit est conçu pour utiliser uniquement des matelas répondant aux spécifications suivantes sur la couchette supérieure et la couchette inférieure : couchette et couchette inférieure :

Couchette supérieure

Type de lit

Double Standard

Longueur

74"-75"

Largeur

38"-39"

6"

Couchette inférieure

Type de lit

Double Standard

Longueur

74"-75"

Largeur

38"-39"

6"

2. Les pièces de rechange, y compris les garde-corps supplémentaires, peuvent être obtenues auprès de l'un de nos revendeurs (GIGACLOUD TECHNOLOGY (USA) INC 4388 Shirley Avenue El Monte, CA 91731).
3. Suivez les informations sur les avertissements apparaissant sur la structure d'extrémité supérieure du lit superposé et sur le carton. Ne retirez pas l'étiquette d'avertissement du lit.
4. Utilisez toujours des matelas ou des supports de matelas de taille recommandée, ou les deux, pour éviter tout risque de coincement ou de chute.
5. La surface du matelas doit être à au moins 5" (127 mm) sous le bord supérieur des garde-corps.
6. Ne laissez pas les enfants de moins de 6 ans utiliser le lit supérieur.
7. Vérifiez et assurez-vous périodiquement que le garde-corps, l'échelle et les autres composants sont dans leur bonne position, exempts de dommages et que tous les connecteurs sont bien serrés.
8. Ne laissez pas les chahuts sur ou sous le lit et interdisez de sauter sur le lit.
9. Utilisez toujours l'échelle pour entrer et sortir du lit supérieur.
10. N'utilisez pas de pièce de rechange. Contactez le fabricant ou le revendeur pour obtenir une pièce de rechange.
11. L'utilisation d'une veilleuse peut fournir une mesure de sécurité supplémentaire pour un enfant utilisant le lit supérieur.
12. Utilisez toujours des garde-corps sur les deux côtés longs du lit supérieur. Si le lit superposé doit être placé à côté du mur, le garde-corps qui s'étend sur toute la longueur du lit doit être placé contre le mur pour éviter tout coincement entre le lit et le mur.
13. L'utilisation de matelas flottants à eau ou de sommeil est interdite.
14. RISQUE D'ÉTRANGULATION - N'attachez ou ne suspendez jamais d'objets à une partie du lit superposé qui ne sont pas conçus pour être utilisés avec le lit ; par exemple, mais sans s'y limiter, les crochets, les ceintures et les cordes à sauter.
15. Conservez ces instructions pour référence future.
16. Interdire plus d'une personne sur la couchette supérieure
17. Nous vous recommandons d'assembler votre lit superposé sur le carton d'expédition pour protéger votre sol ou votre tapis.
18. Assurez-vous que toutes les agrafes sont sorties de la boîte avant de commencer l'assemblage sur le carton d'expédition.

N737P190975.N737P190977

Page 2 of 31/Page 2 sur 31

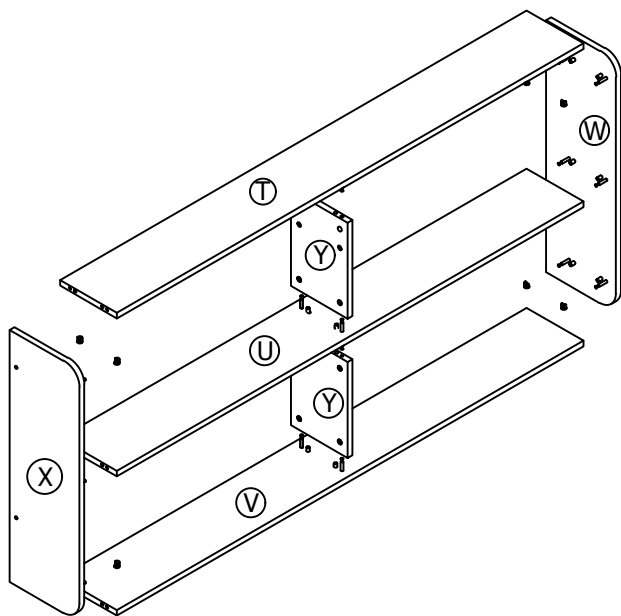
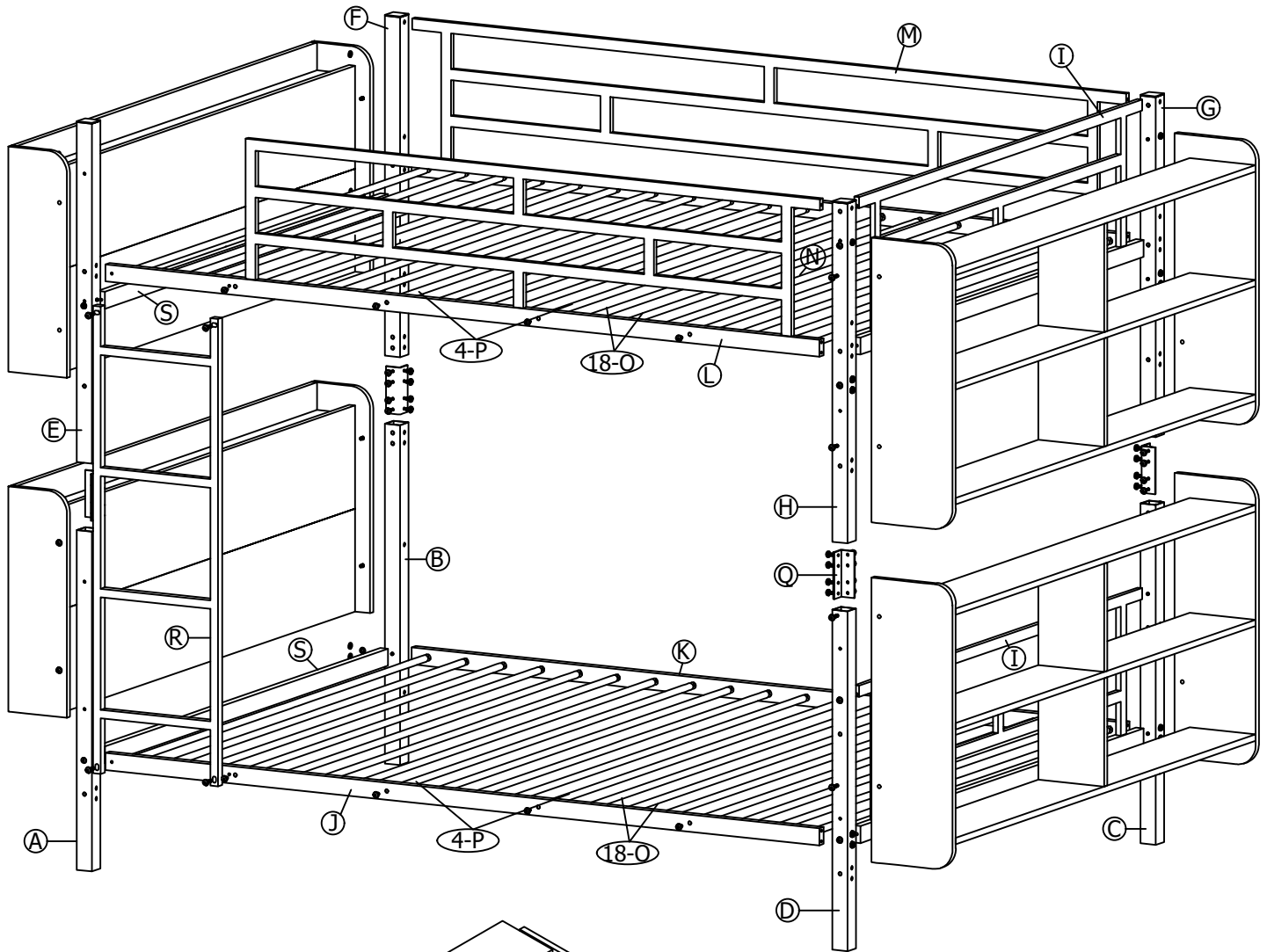

BOOKSHELFS 1/ÉTAGÈRE À LIVRES 1
 QTY/QTE: 02

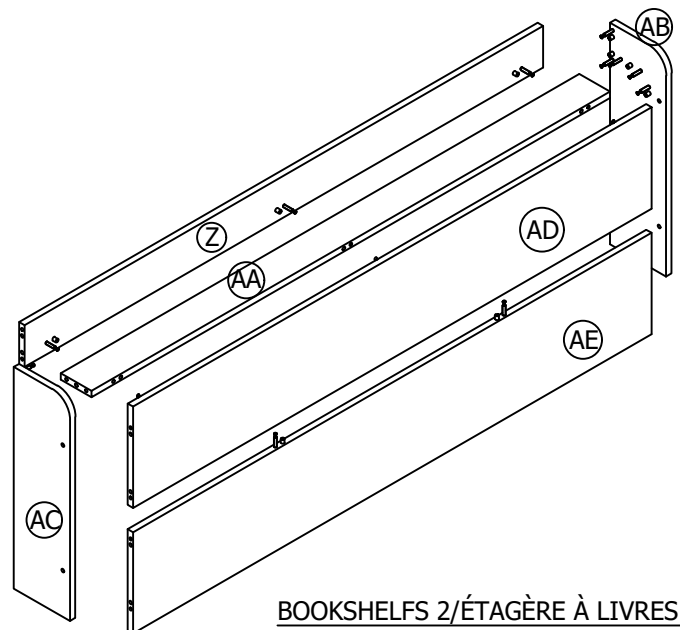

BOOKSHELFS 2/ÉTAGÈRE À LIVRES 2
 QTY/QTE: 02

ASSEMBLY TOOLS REQUIRED/ OUTILS DE MONTAGE NÉCESSAIRES

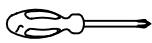
 Phillip head screwdriver/Tournevis à tête

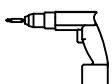
 Power tools assemble this product/
 Les outils électriques assemblent ce produit

PARTS LIST/LISTE DES PIÈCES

N737P190977

A Foot of bed/Pied de lit

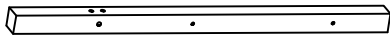

QTY: 1 pcs

B Foot of bed/Pied de lit

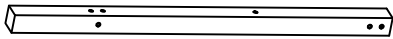

QTY: 1 pcs

C Foot of bed/Pied de lit

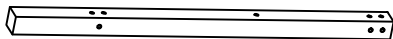

QTY: 1 pcs

D Foot of bed/Pied de lit

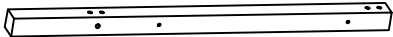

QTY: 1 pcs

E Foot of bed/Pied de lit



QTY: 1 pcs

F Foot of bed/Pied de lit

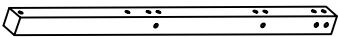

QTY: 1 pcs

G Foot of bed/Pied de lit

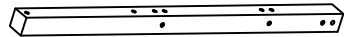

QTY: 1 pcs

H Foot of bed/Pied de lit

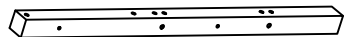

QTY: 1 pcs

S Bed ladder/Échelle de lit

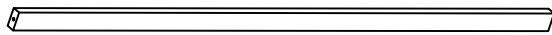

QTY: 2 pcs

I Bed ladder/Échelle de lit

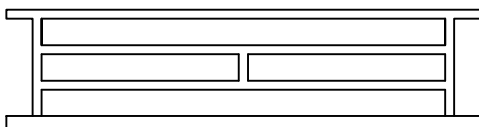

QTY: 2 pcs

J Bed ladder/Échelle de lit

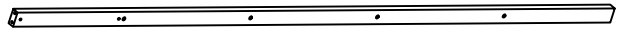

QTY: 1 pcs

K Bed ladder/Échelle de lit

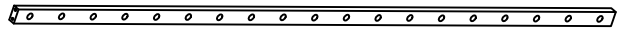

QTY: 1 pcs

L Bed rails/Rampes de lit

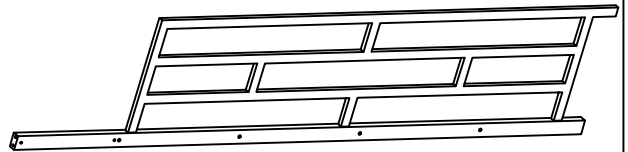

QTY: 1 pcs

M Bed rails/Rampes de lit

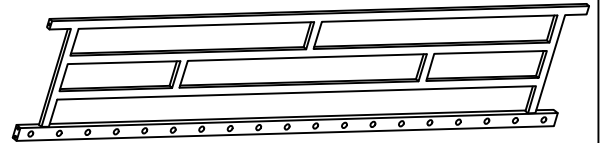

QTY: 1 pcs

O Iron pipe/Tuyau en fer



QTY: 36 pcs

P Iron pipe/Tuyau en fer



QTY: 8 pcs

Q Link details/Détails du lien

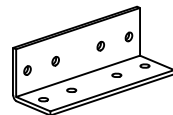

QTY: 4 pcs

R Stairs/Escaliers

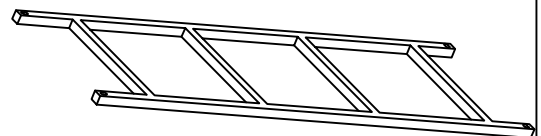

QTY: 1 pcs

PARTS LIST/LISTE DES PIECES

N737P190975

T Wood panels / panneaux de bois

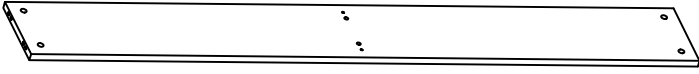

QTY: 2 pcs

Z Wood panels / panneaux de bois



QTY: 2 pcs

U Wood panels / panneaux de bois



QTY: 2 pcs

AA Wood panels / panneaux de bois



QTY: 2 pcs

V Wood panels / panneaux de bois



QTY: 2 pcs

AB Wood panels / panneaux de bois



QTY: 2 pcs

W Wood panels / panneaux de bois

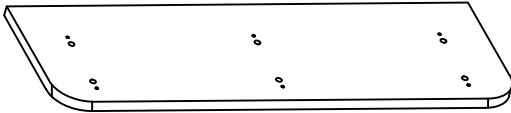

QTY: 2 pcs

AC Wood panels / panneaux de bois



QTY: 2 pcs

X Wood panels / panneaux de bois

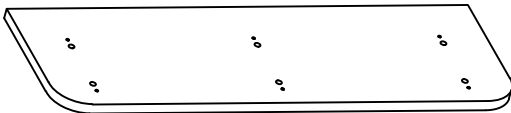

QTY: 2 pcs

AE Wood panels / panneaux de bois

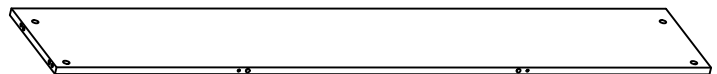

QTY: 2 pcs

Y Wood panels / panneaux de bois

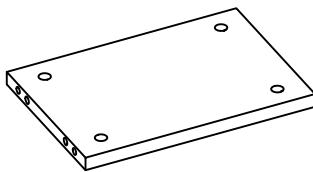

QTY: 4 pcs



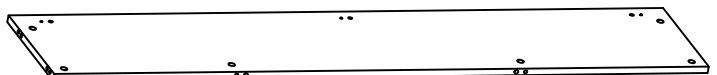



AD Wood panels / panneaux de bois

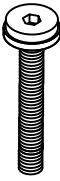

QTY: 2 pcs

Hardware List/ Liste du matériel

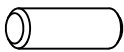
N737P190977

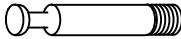
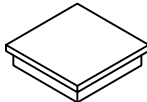
1		1/4 x50	x27
2		1/4 x30	x20
3		1/4 x15	x48
4		4 x48	x1
5		Positioning pin Ø8xL30 Goupille de positionnement Ø8xL30	x76
6	Cam latch 1		x90
7	Cam latch 2		x90
8	PLASTIC BUTTON		x8

STEP 1-1 / ÉTAPE 1-1

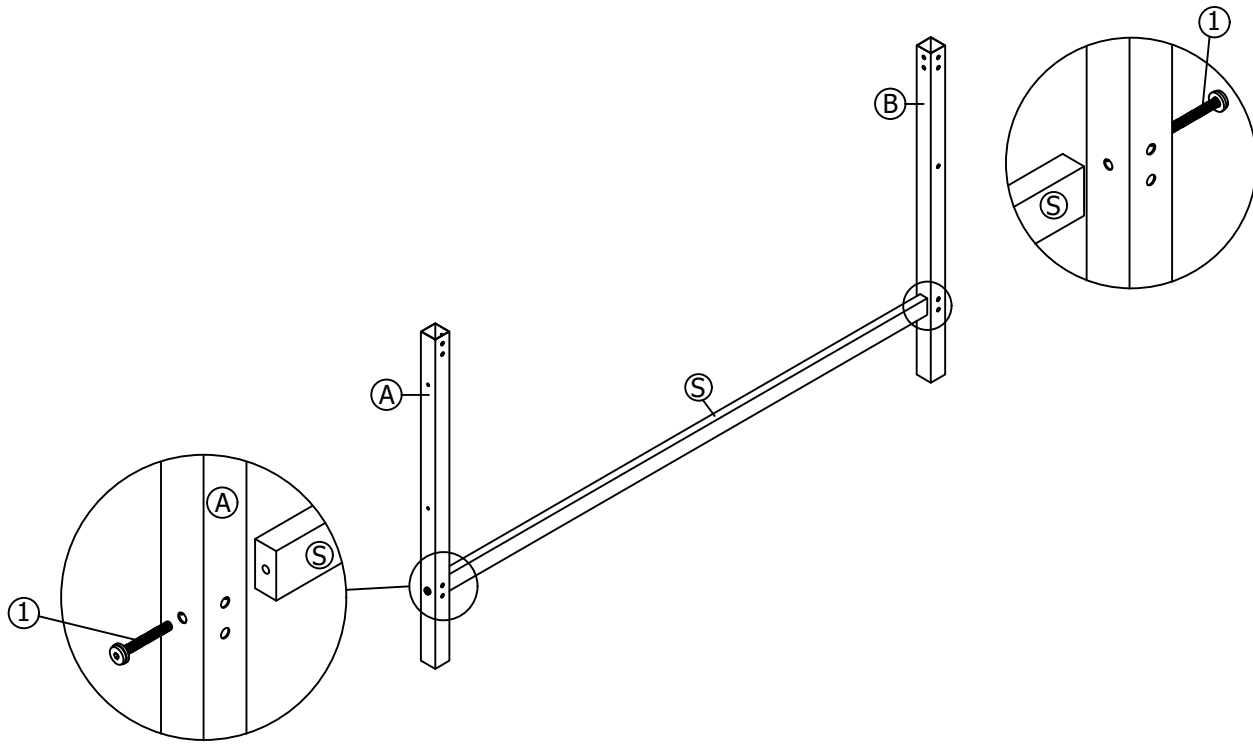

Hardware/Matériel		
Code	Image	Qty/Qte
1		2 pcs

STEP 1-2 / ÉTAPE 1-2

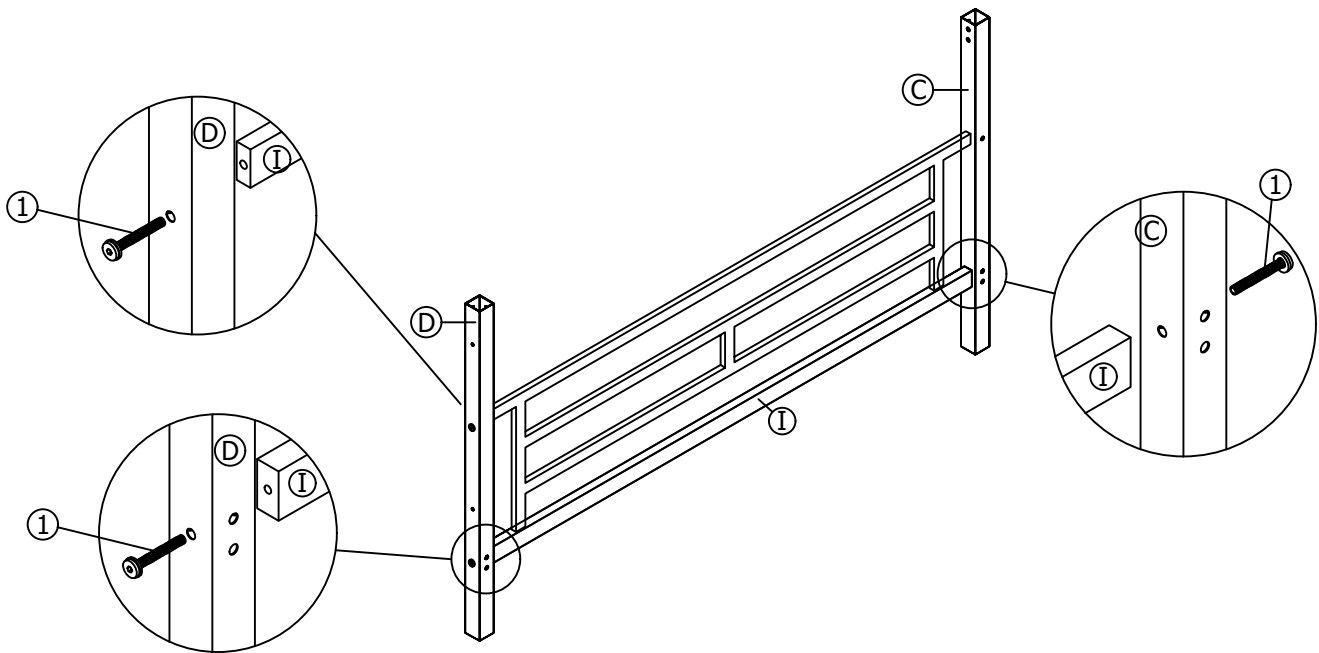

Hardware/Matériel		
Code	Image	Qty/Qte
1		4 pcs

STEP 1-3 / ÉTAPE 1-3

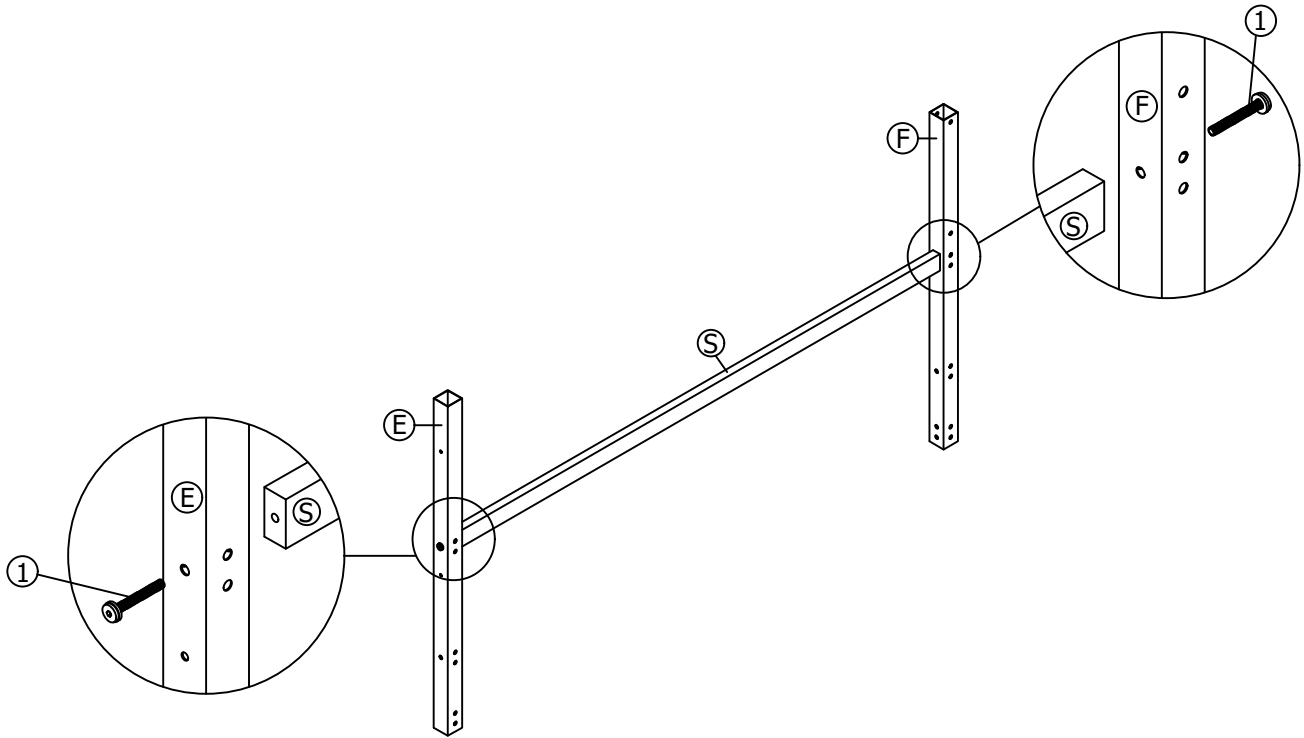

Hardware/Matériel		
Code	Image	Qty/Qte
1		2 pcs

STEP 1-4 / ÉTAPE 1-4

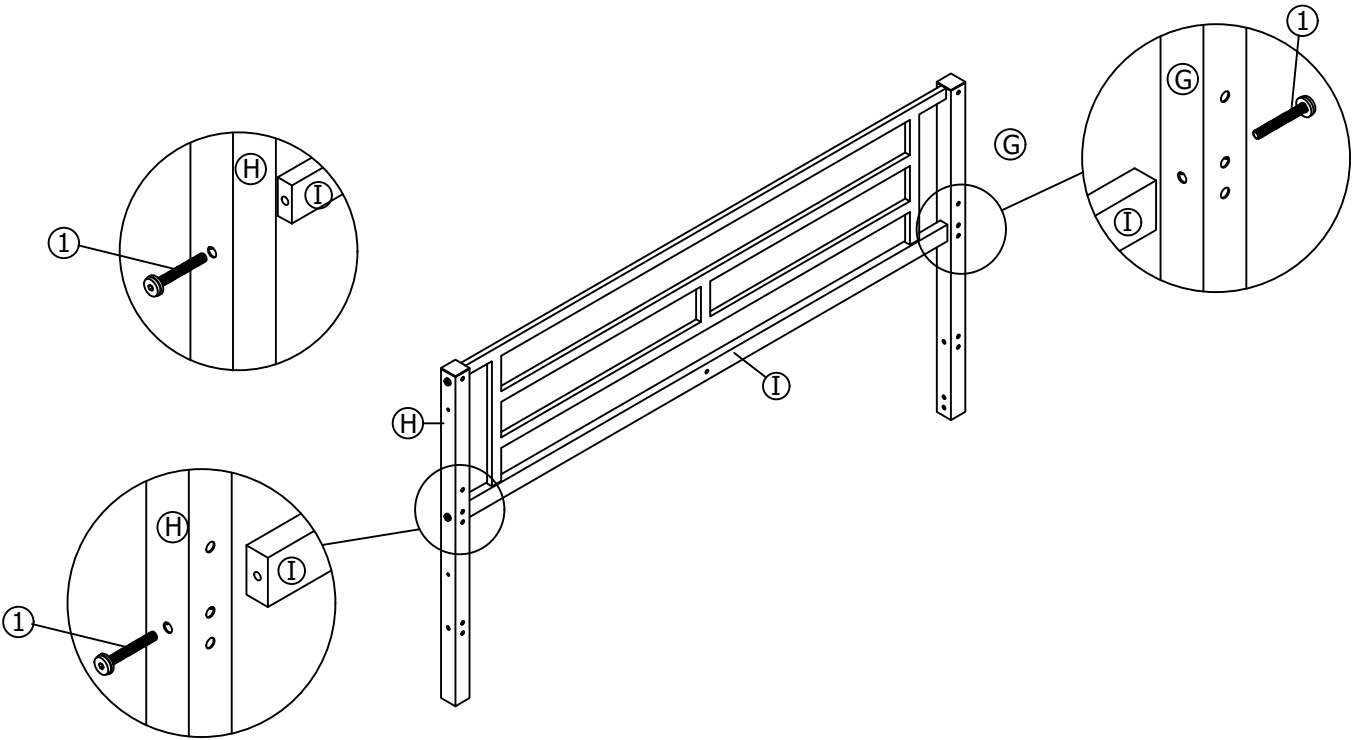

Hardware/Matériel		
Code	Image	Qty/Qte
1		4 pcs

STEP 2-1 / ÉTAPE 2-1

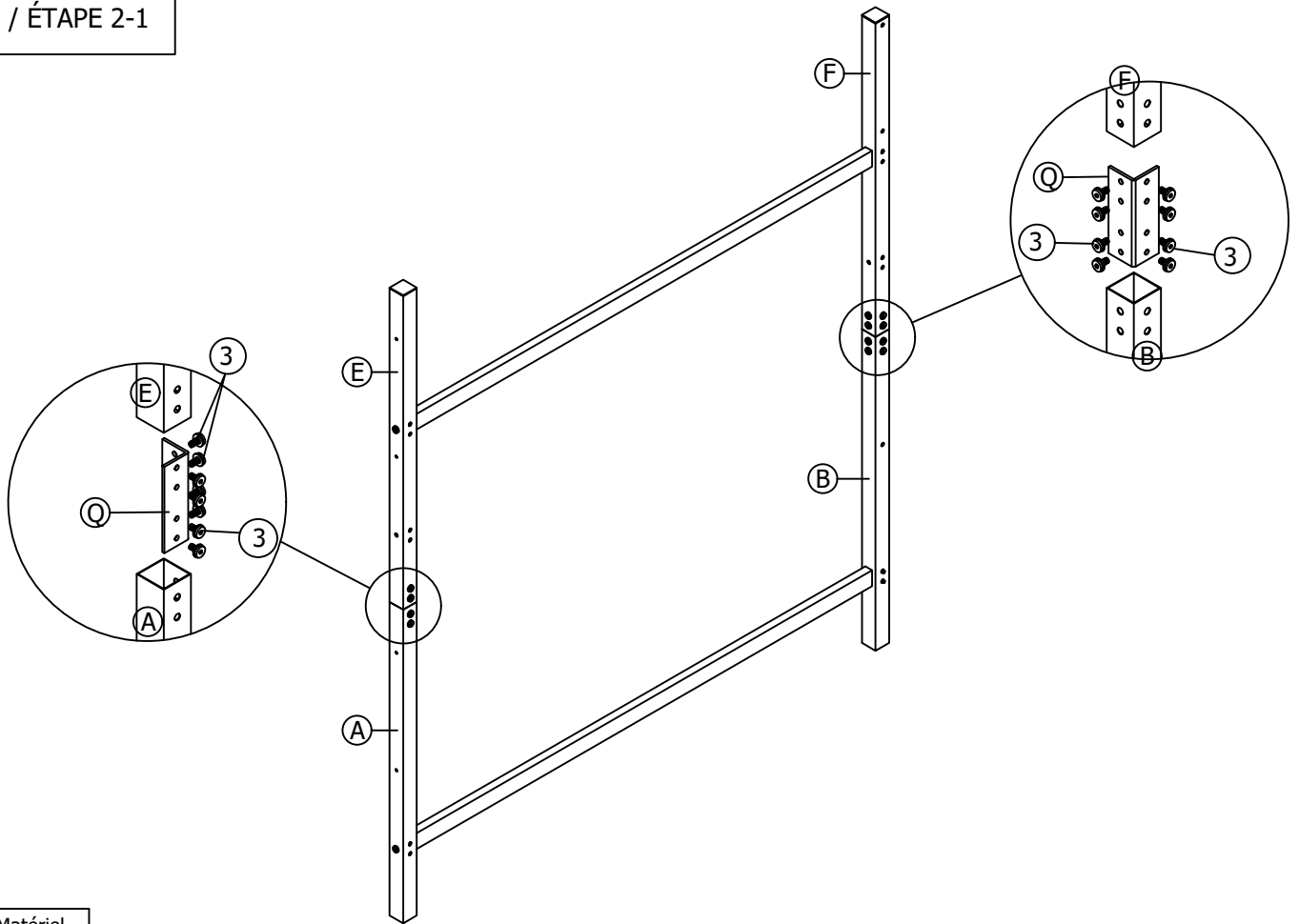

Hardware/Matériel		
Code	Image	Qty/Qte
3		16 pcs

STEP 2-2 / ÉTAPE 2-2

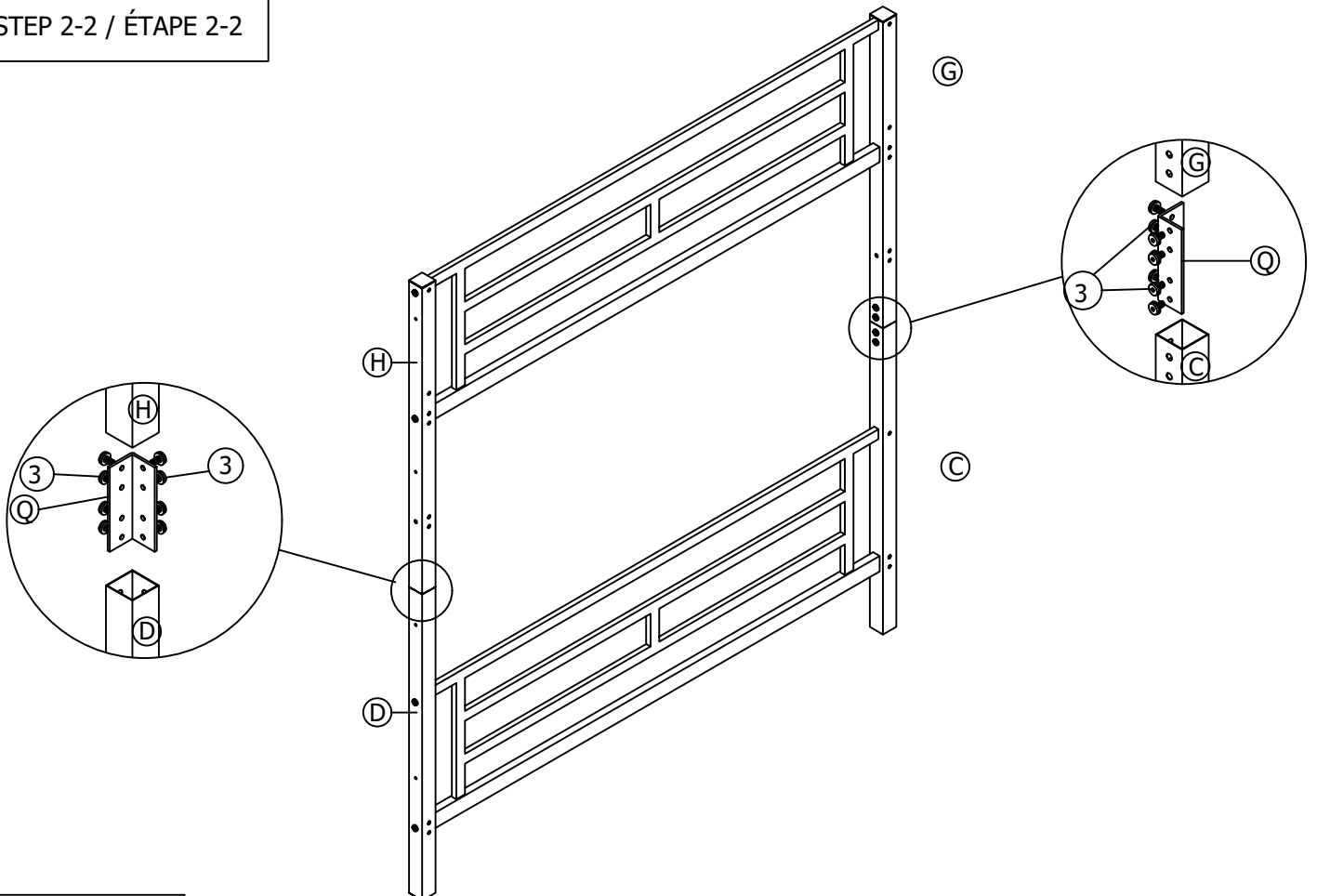

Hardware/Matériel		
Code	Image	Qty/Qte
3		16 pcs

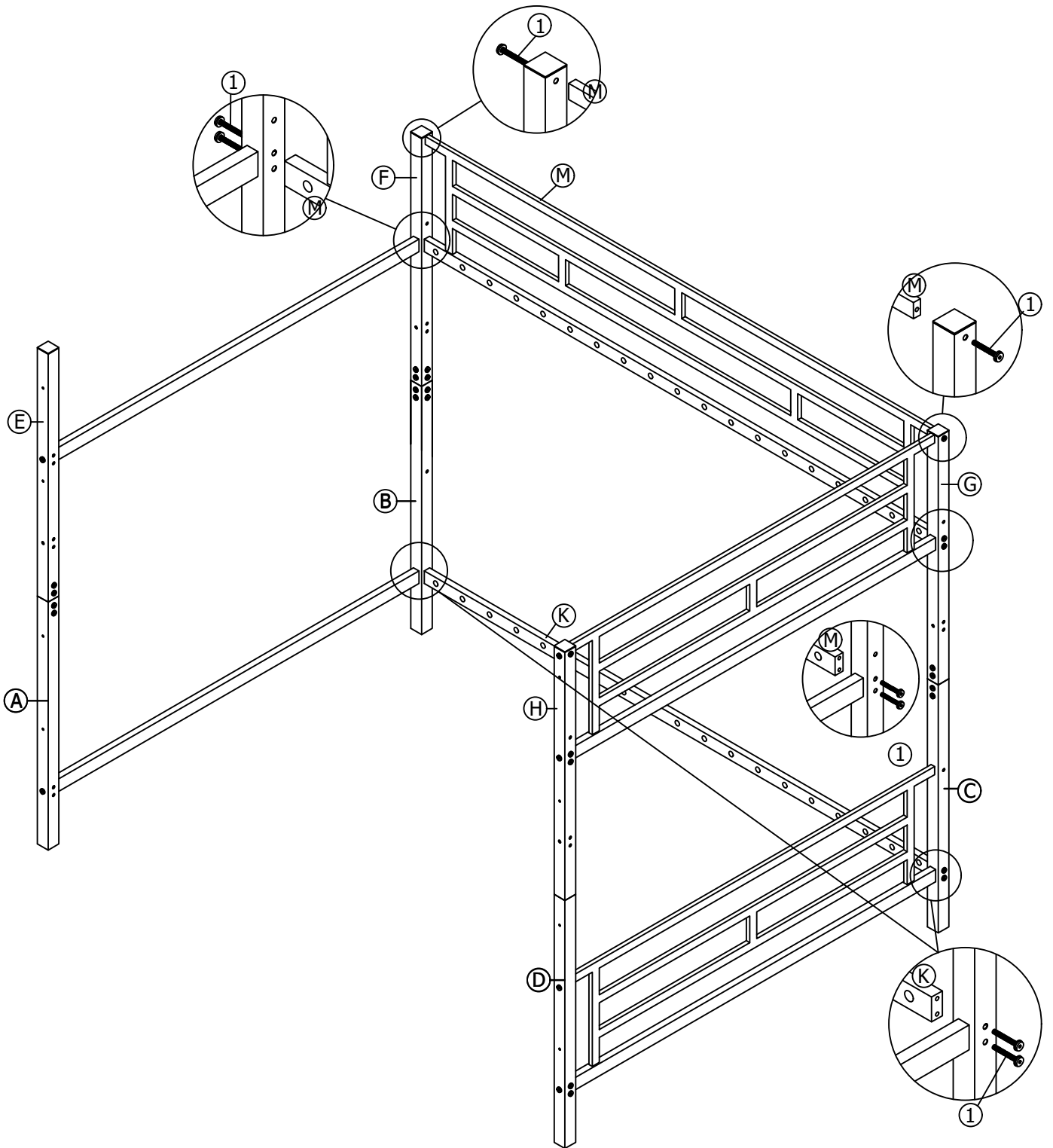

STEP 3 / ÉTAPE 3

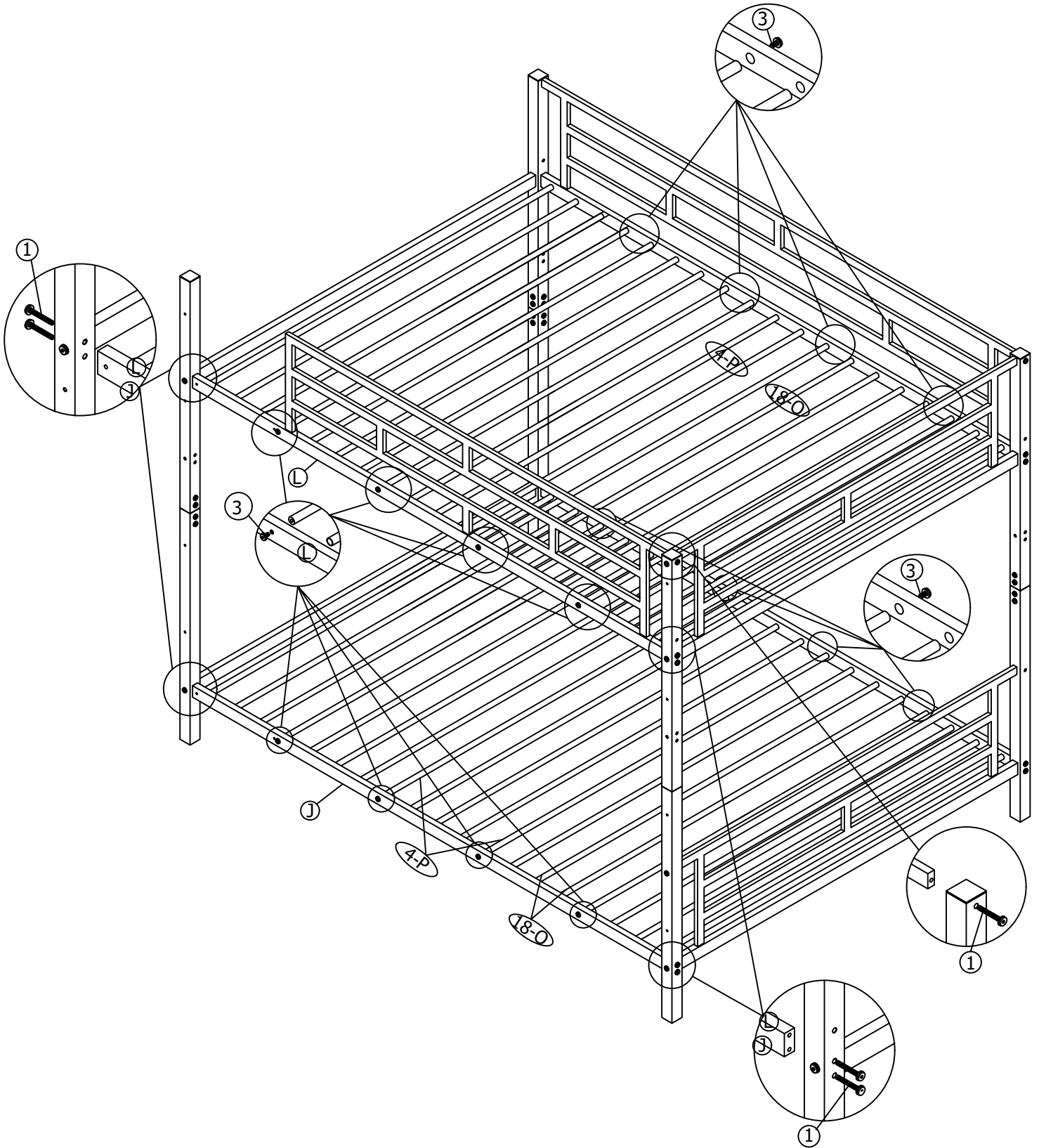

Hardware/Matériel		
Code	Image	Qty/Qte
1		10 pcs

STEP 4 / ÉTAPE 4



Hardware/Matériel		
Code	Image	Qty/Qte
1		9 pcs
3		16 pcs

STEP 5 / ÉTAPE 5

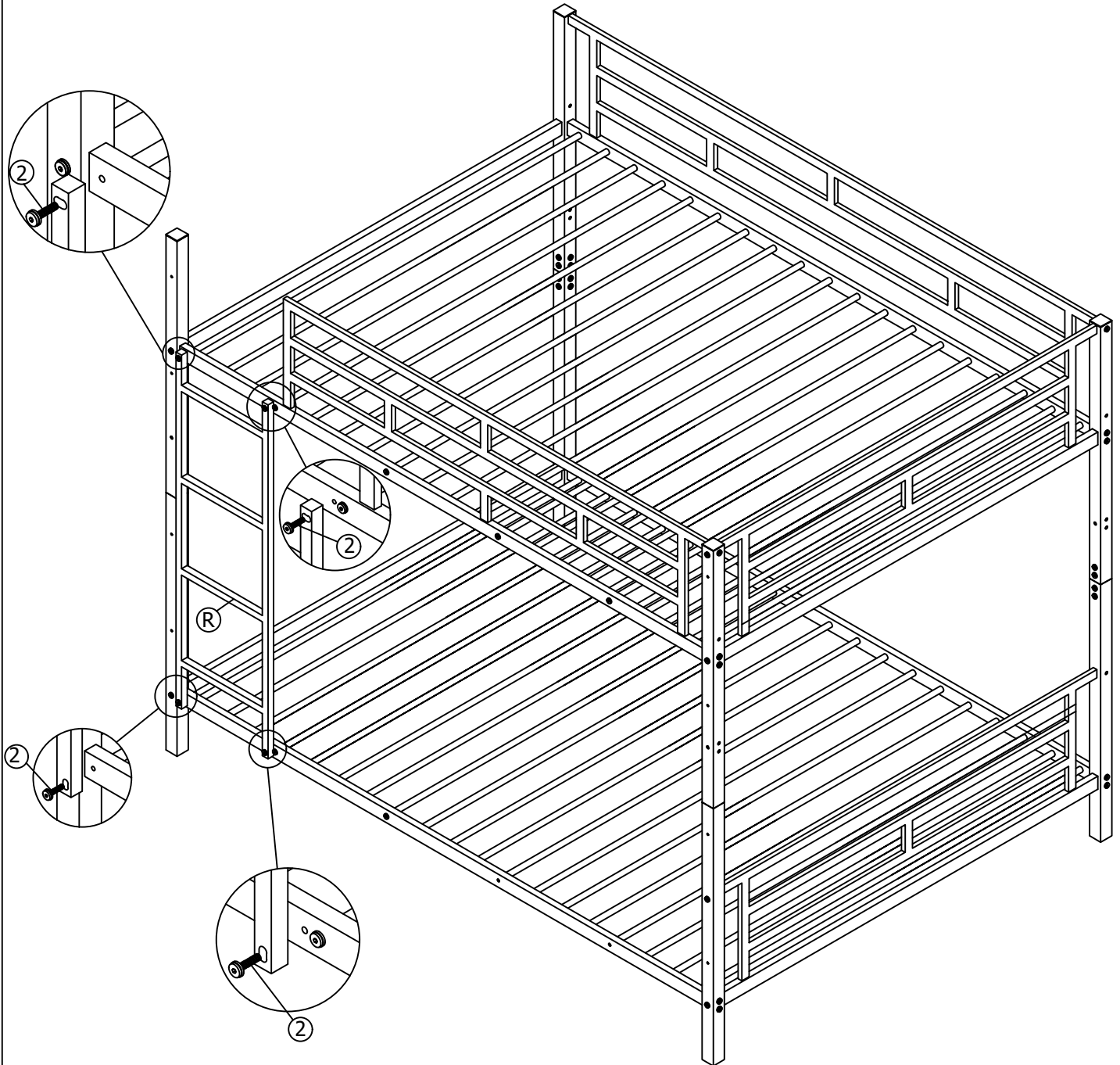

Hardware/Matériel		
Code	Image	Qty/Qte
2		4 pcs

STEP 6-1 / ÉTAPE 6-1

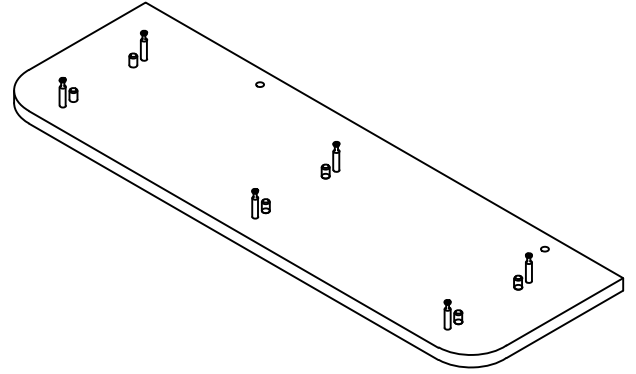
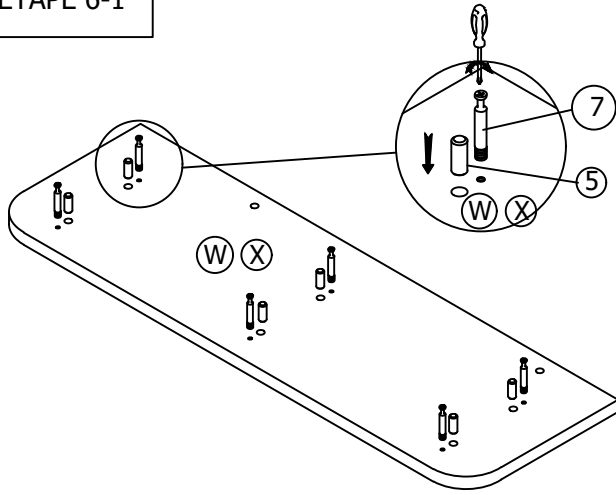

Hardware/Matériel		
Code	Image	Qty/Qte
5		24 pcs
7		24 pcs

QTY/QTE: 04

STEP 6-2 / ÉTAPE 6-2

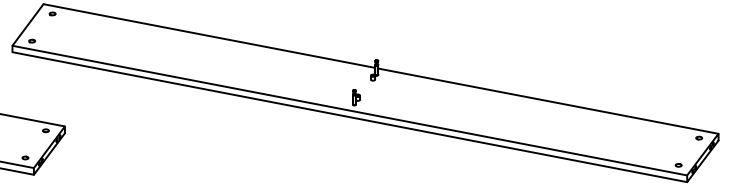
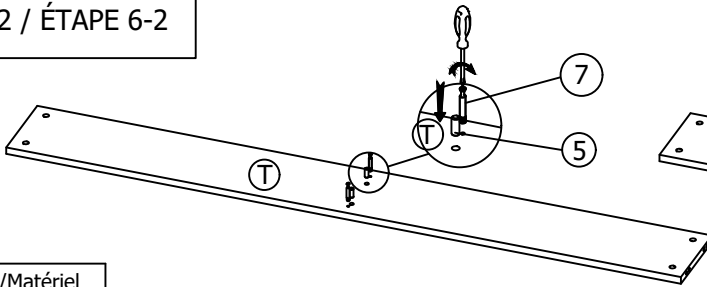

Hardware/Matériel		
Code	Image	Qty/Qte
5		4 pcs
7		4 pcs

QTY/QTE: 02

STEP 6-3 / ÉTAPE 6-3

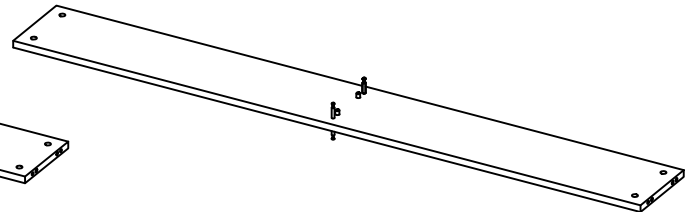
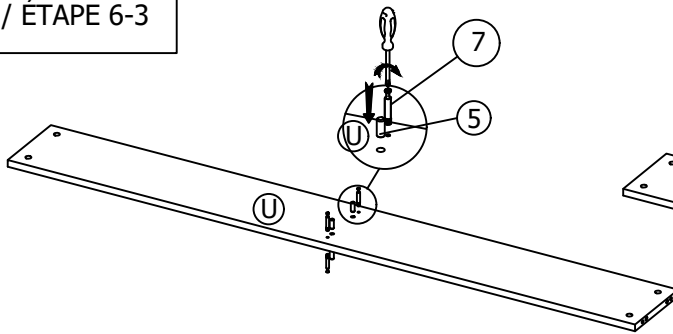

Hardware/Matériel		
Code	Image	Qty/Qte
5		8 pcs
7		8 pcs

QTY/QTE: 02

STEP 6-4 / ÉTAPE 6-4

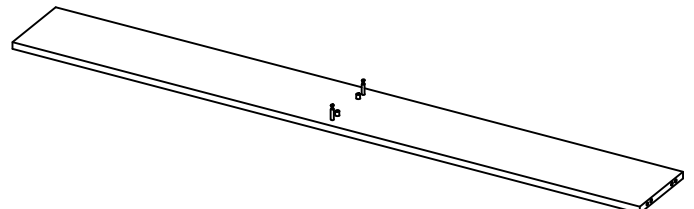
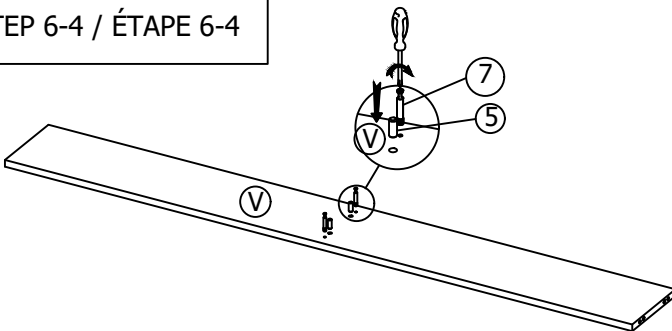

Hardware/Matériel		
Code	Image	Qty/Qte
5		4 pcs
7		4 pcs

QTY/QTE: 02

STEP 7 / ÉTAPE 7

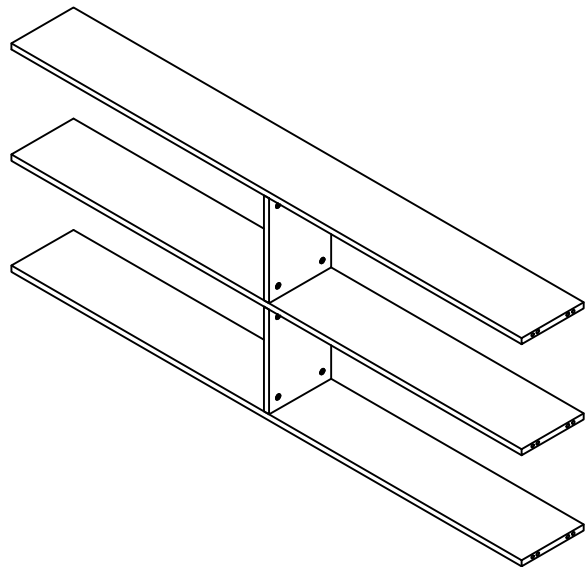
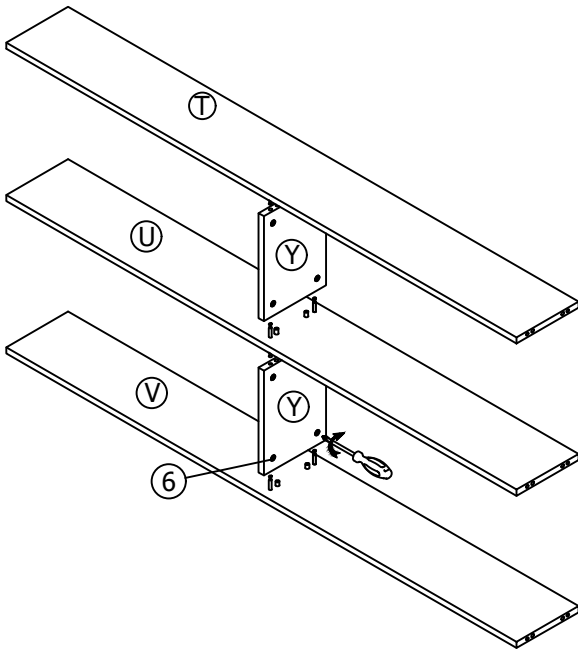

QTY/QTE: 02

Hardware/Matériel		
Code	Image	Qty/Qte
6		16 pcs

STEP 8 / ÉTAPE 8

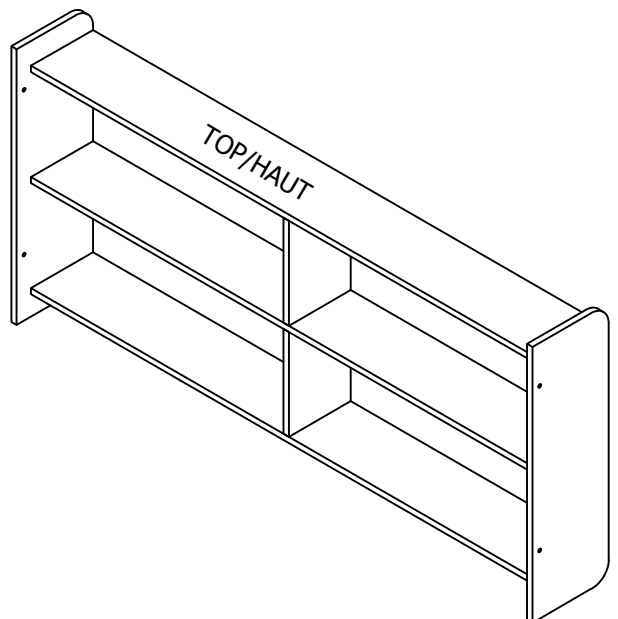
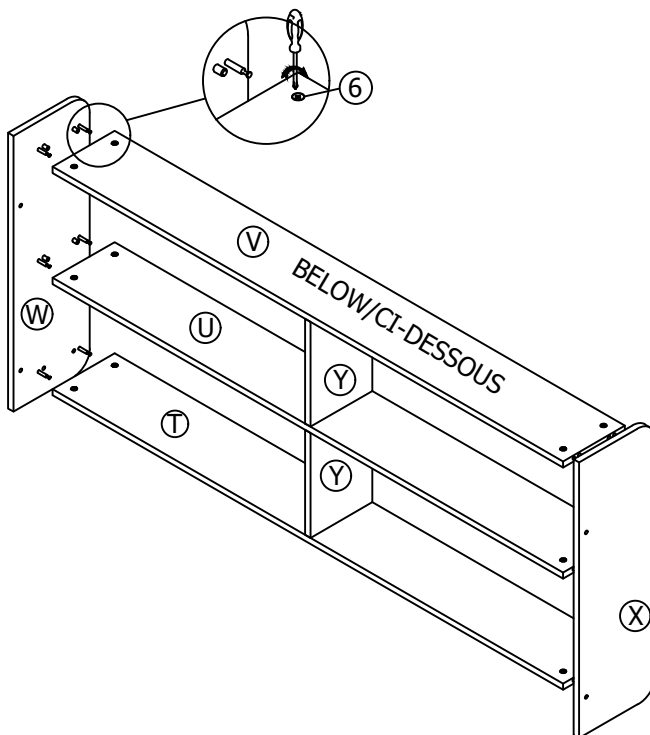

QTY/QTE: 02

Hardware/Matériel		
Code	Image	Qty/Qte
6		24 pcs

STEP 9-1 / ÉTAPE 9-1

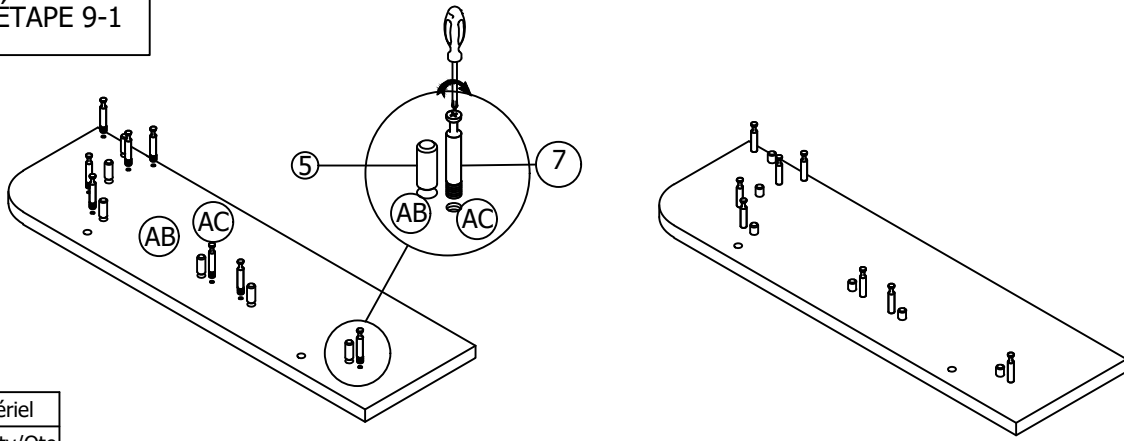

Hardware/Matériel		
Code	Image	Qty/Qte
5		24 pcs
7		32 pcs

QTY/QTE: 04

STEP 9-2 / ÉTAPE 9-2

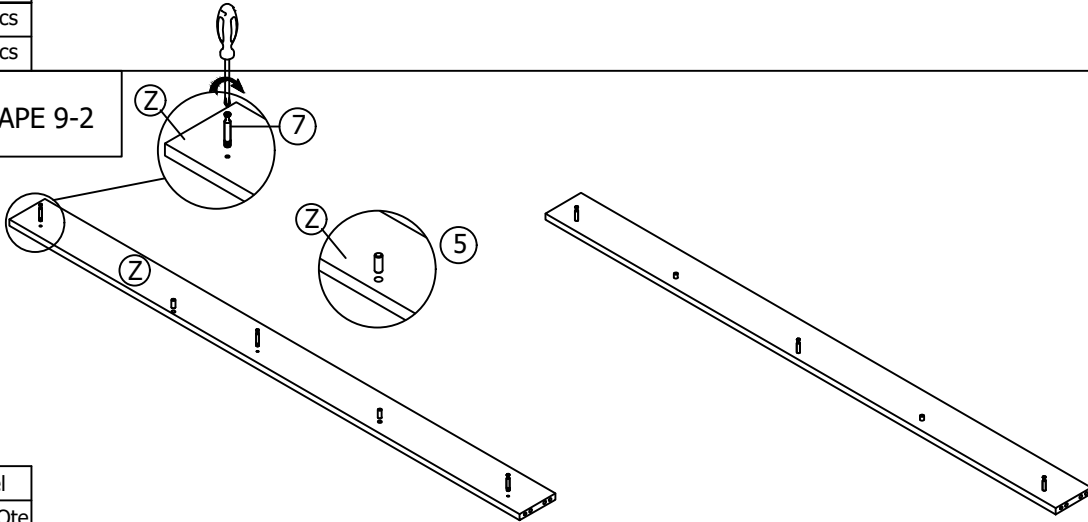

Hardware/Matériel		
Code	Image	Qty/Qte
5		4 pcs
7		6 pcs

QTY/QTE: 02

STEP 9-3 / ÉTAPE 9-3

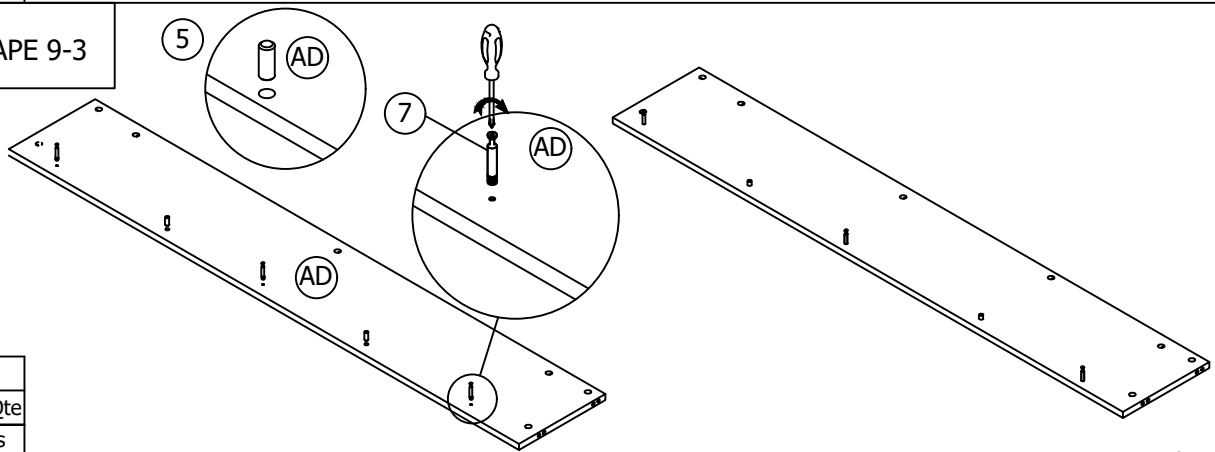

Hardware/Matériel		
Code	Image	Qty/Qte
5		4 pcs
7		6 pcs

QTY/QTE: 02

STEP 9-4 / ÉTAPE 9-4

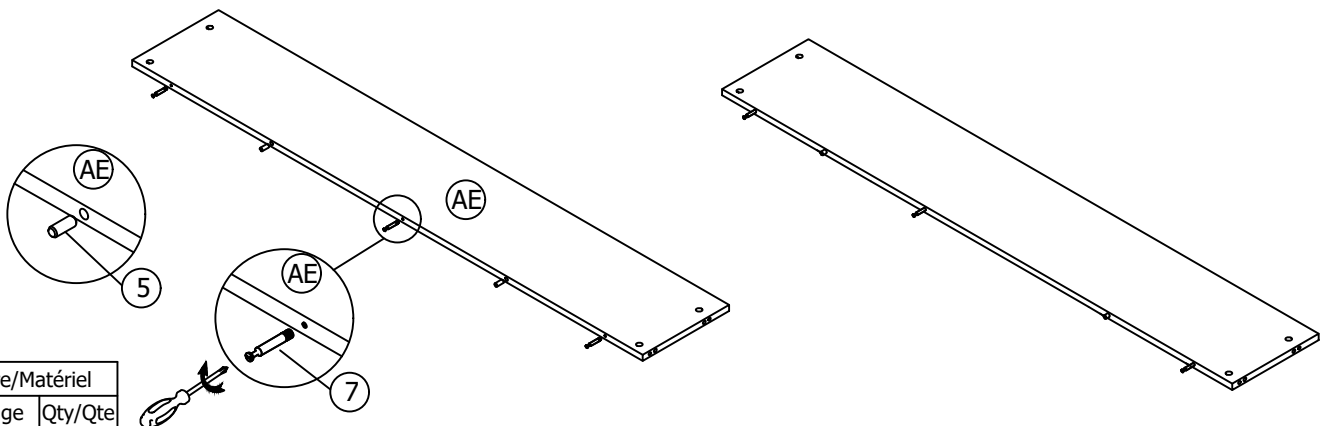

Hardware/Matériel		
Code	Image	Qty/Qte
5		4 pcs
7		6 pcs

QTY/QTE: 02

STEP 10-1 / ÉTAPE 10-1

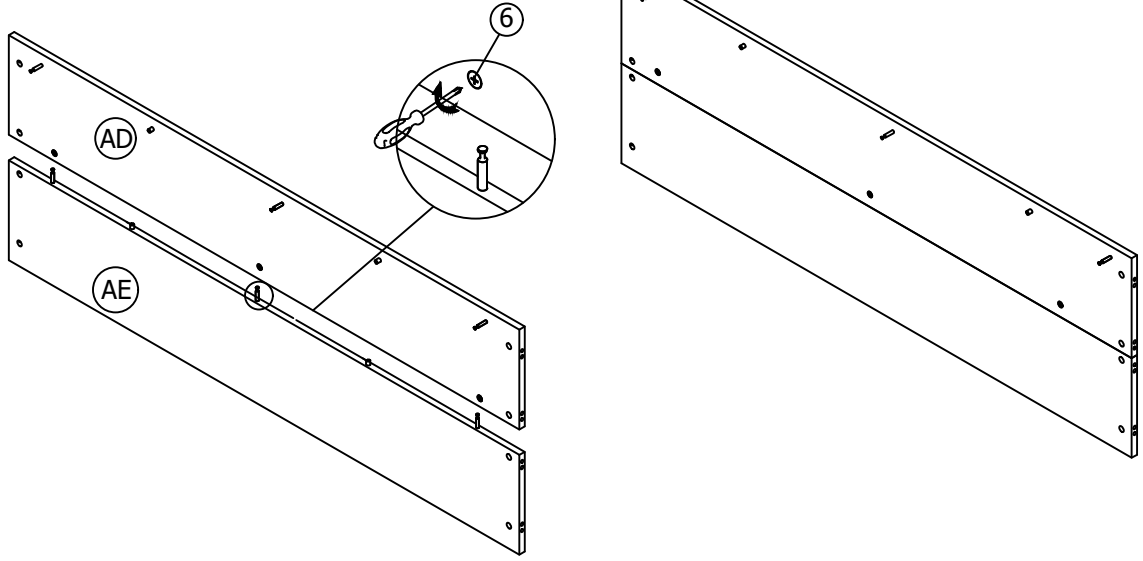

Hardware/Matériel		
Code	Image	Qty/Qte
6		6 pcs

QTY/QTE: 02

STEP 10-2 / ÉTAPE 10-2

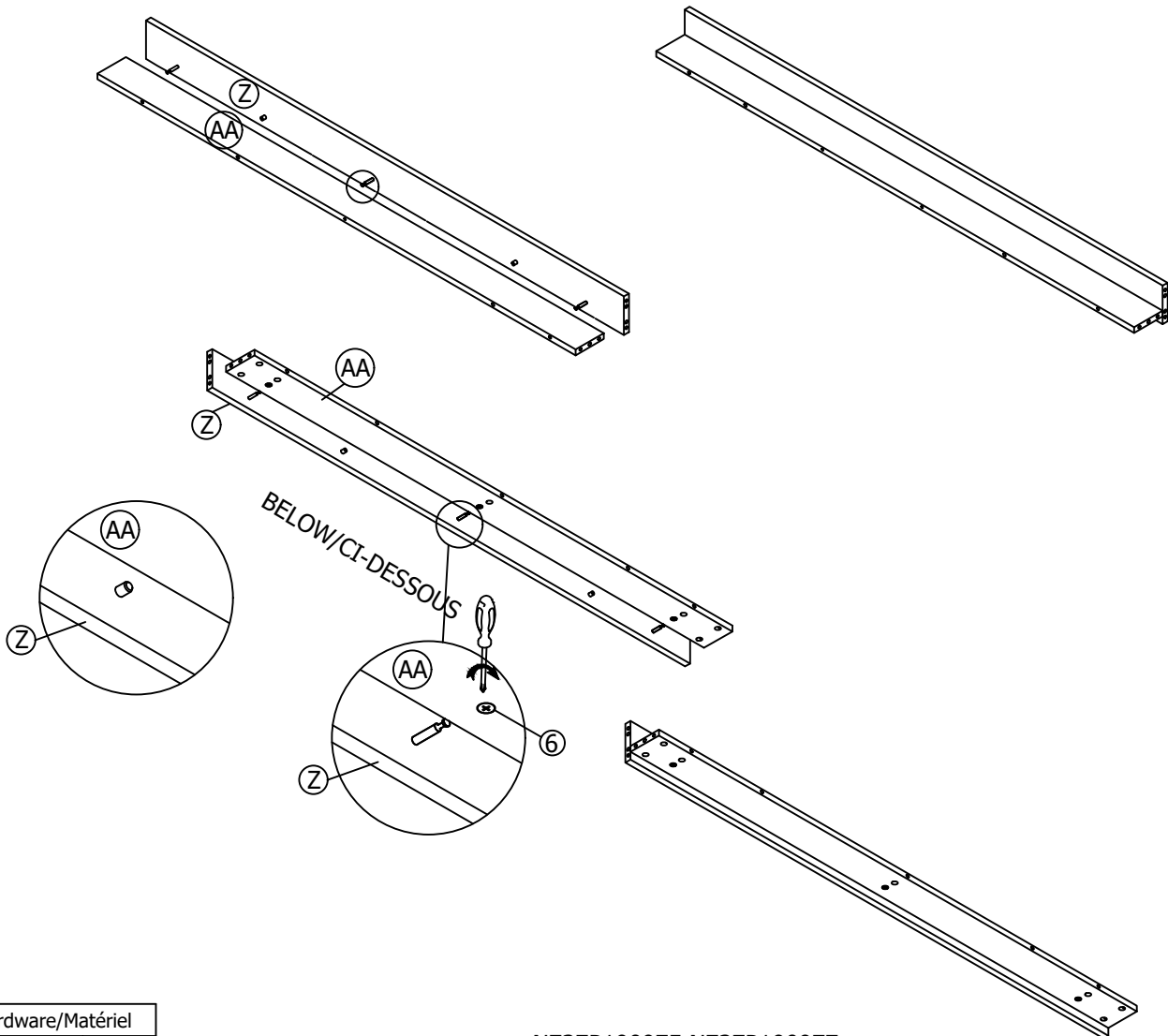

Hardware/Matériel		
Code	Image	Qty/Qte
6		6 pcs

QTY/QTE: 02

STEP 11 / ÉTAPE 11

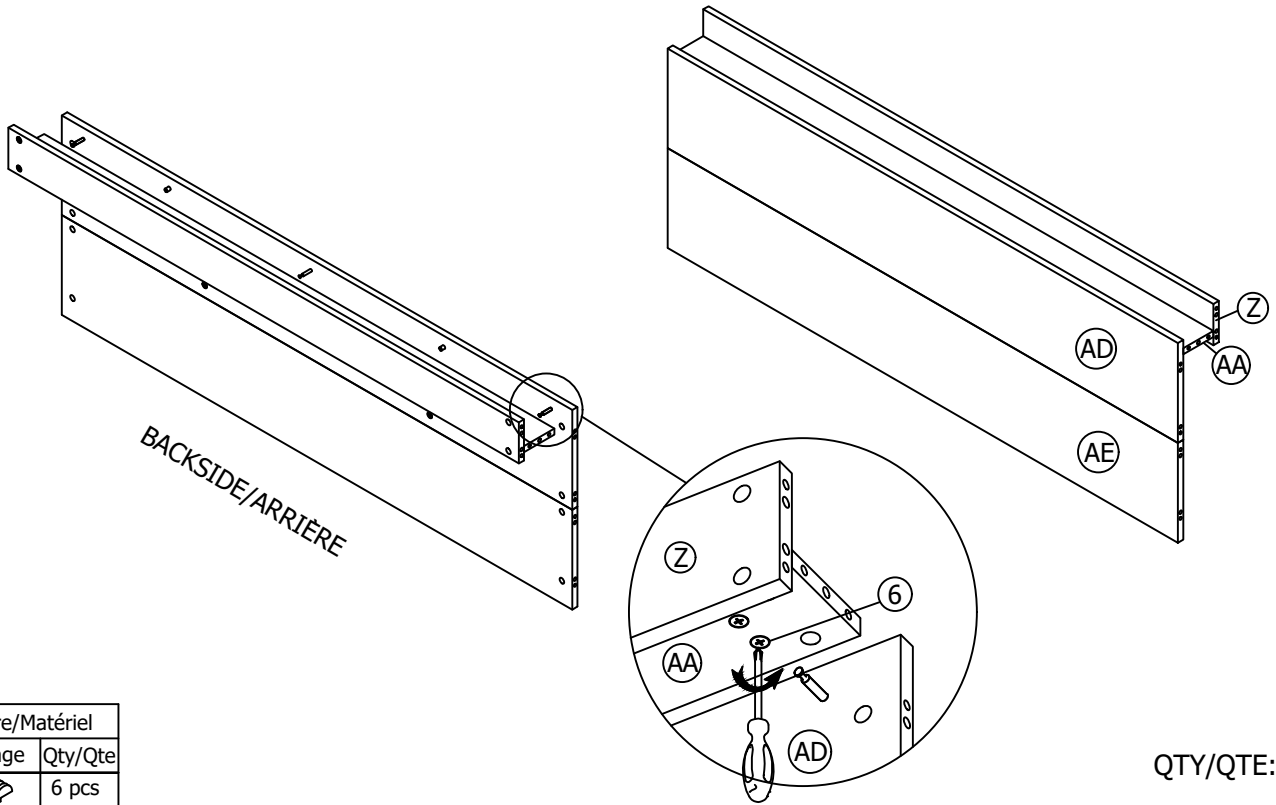

Hardware/Matériel		
Code	Image	Qty/Qte
6		6 pcs

QTY/QTE: 02

STEP 12 / ÉTAPE 12

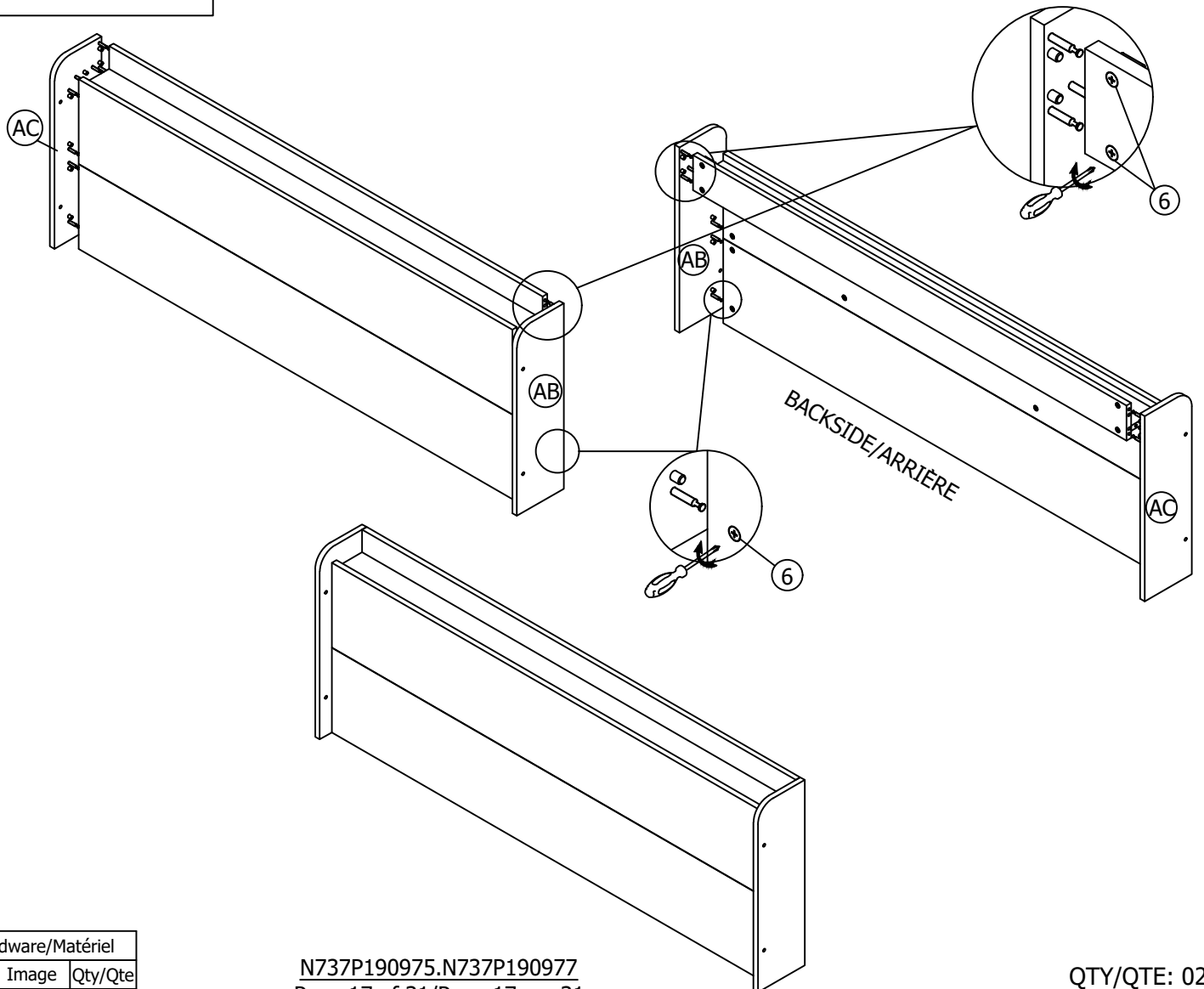

Hardware/Matériel		
Code	Image	Qty/Qte
6		32 pcs

QTY/QTE: 02

STEP 13 / ÉTAPE 13

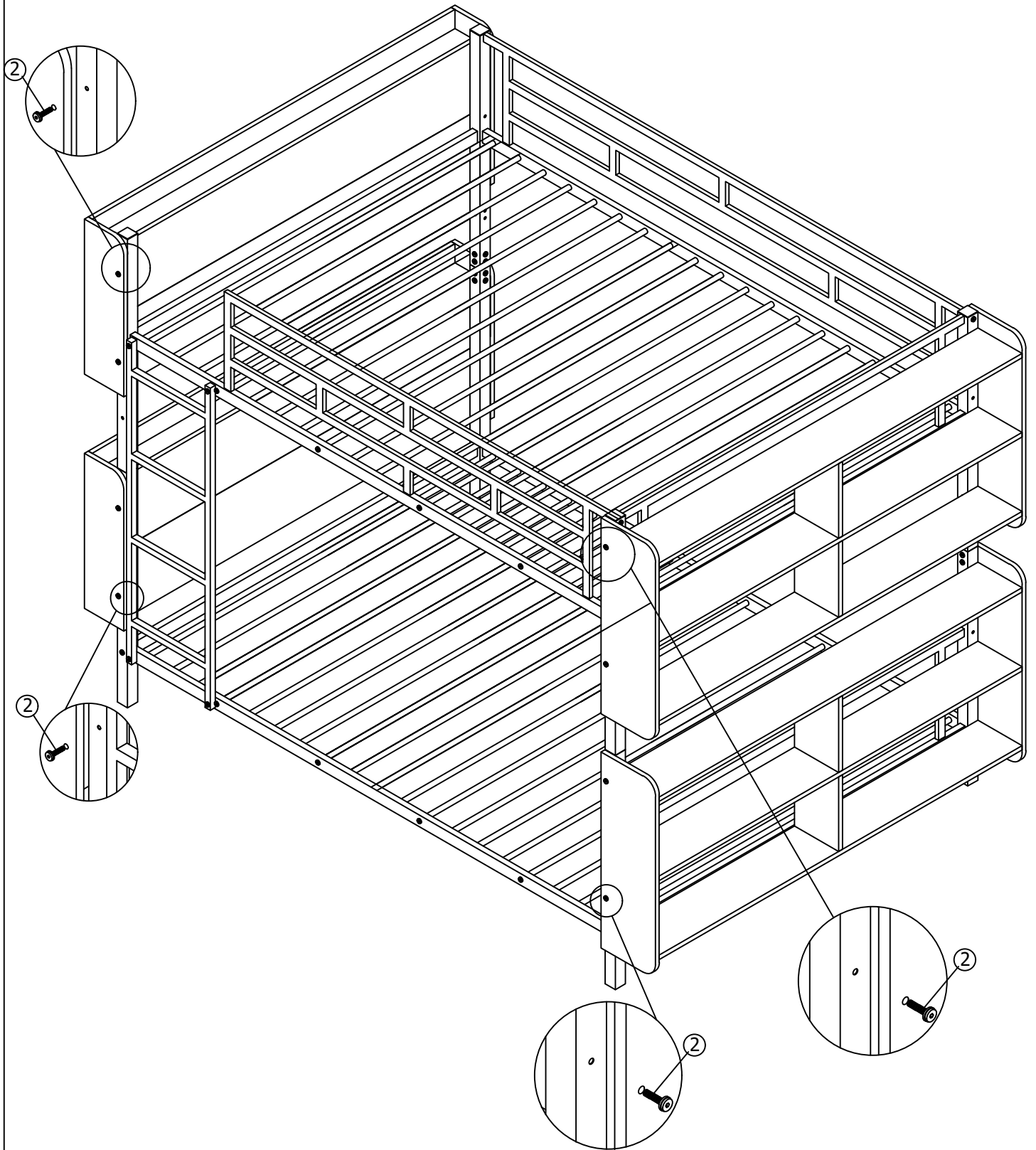

Hardware/Matériel		
Code	Image	Qty/Qte
2		16 pcs

FINISH/FINITION

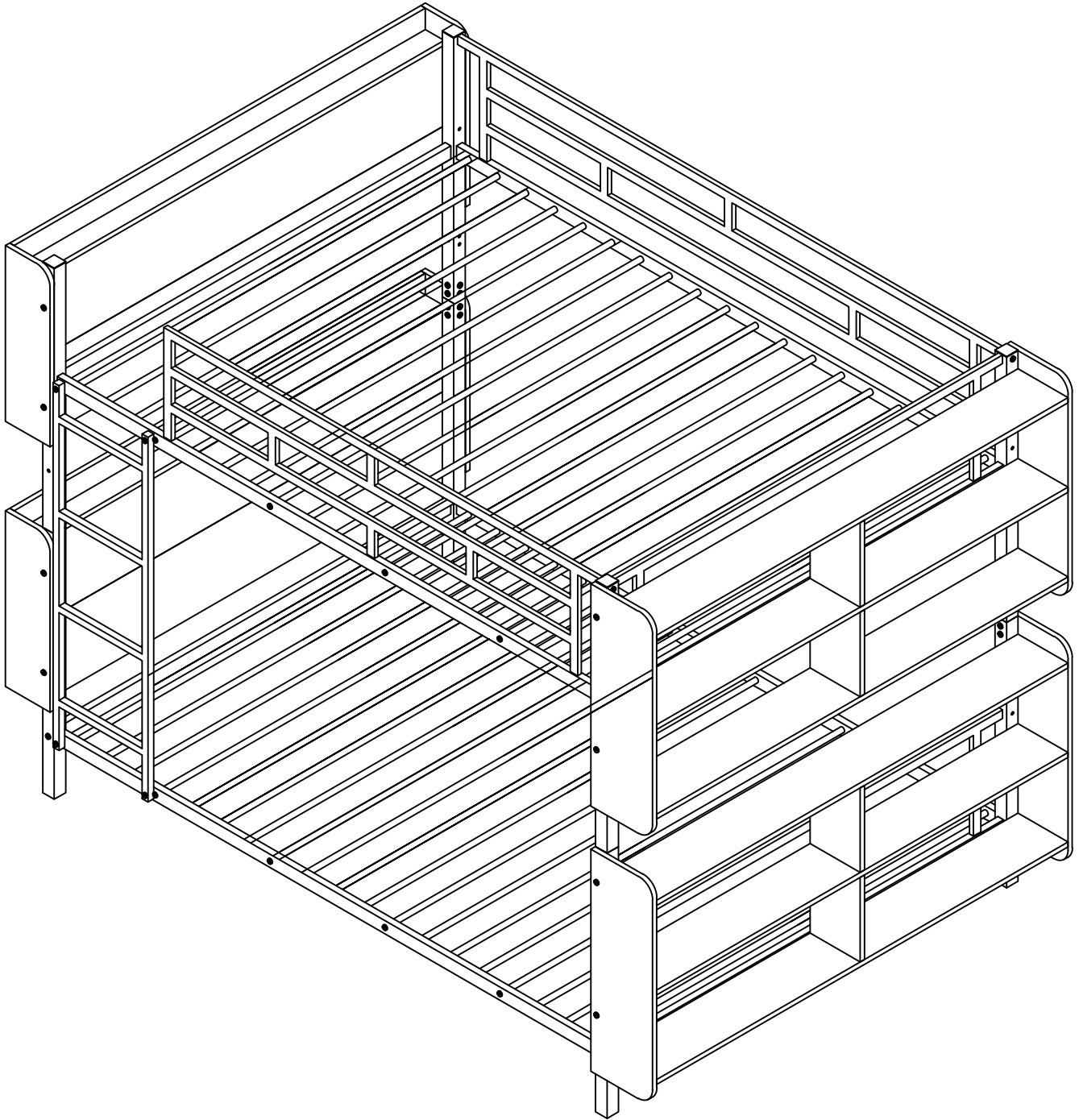

TWIN BUNKBED WITH 4 BOOKSHELFS / LIT DOUBLE SUPERPOSÉ AVEC 4 ÉTAGÈRES

ASSEMBLY INSTRUCTIONS / INSTRUCTIONS DE MONTAGE
FULL BED WITH 2 BOOKSHELFS / LIT COMPLET AVEC 2 BIBLIOTHÈQUES

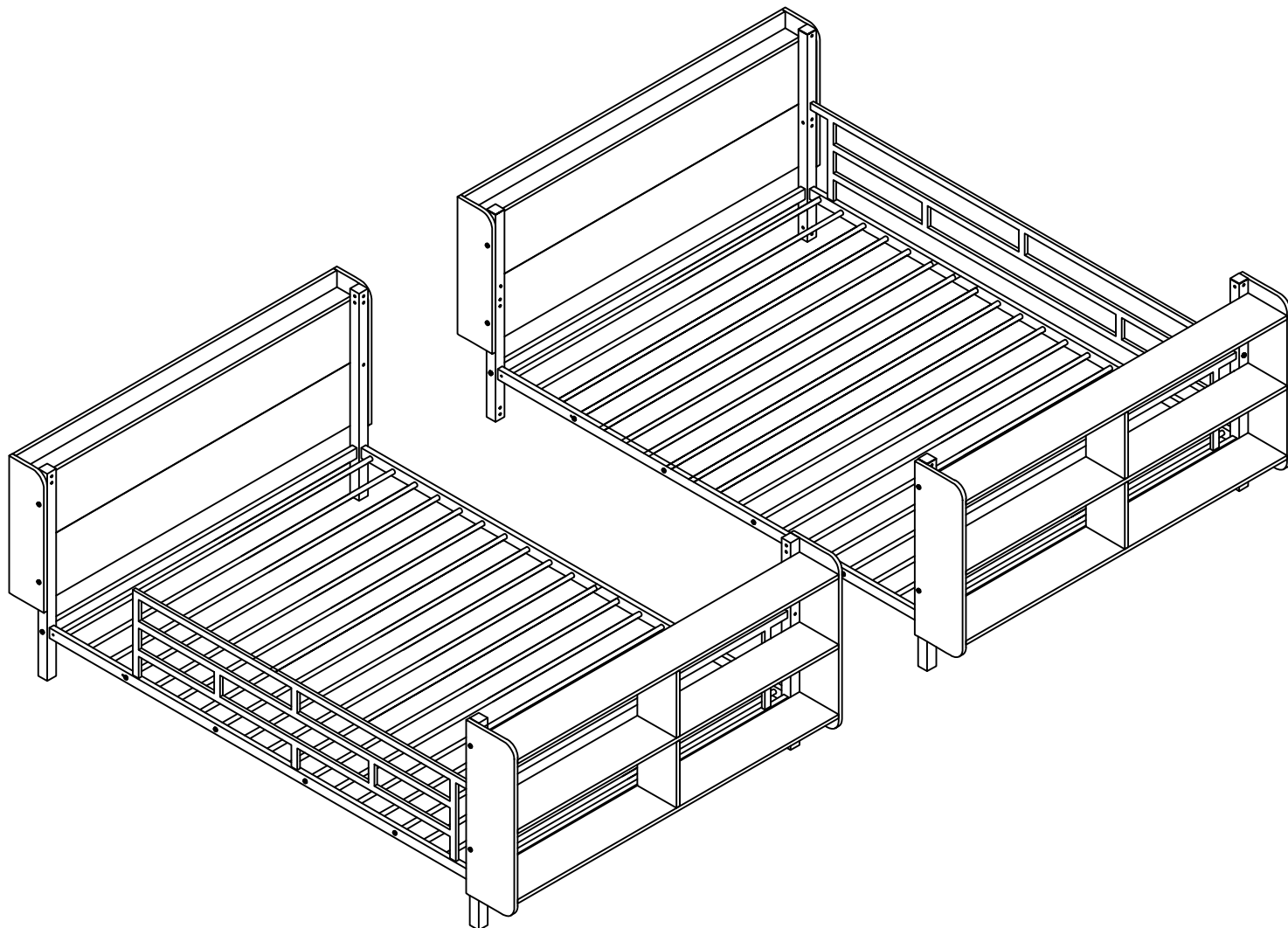

STEP 1-1 / ÉTAPE 1-1

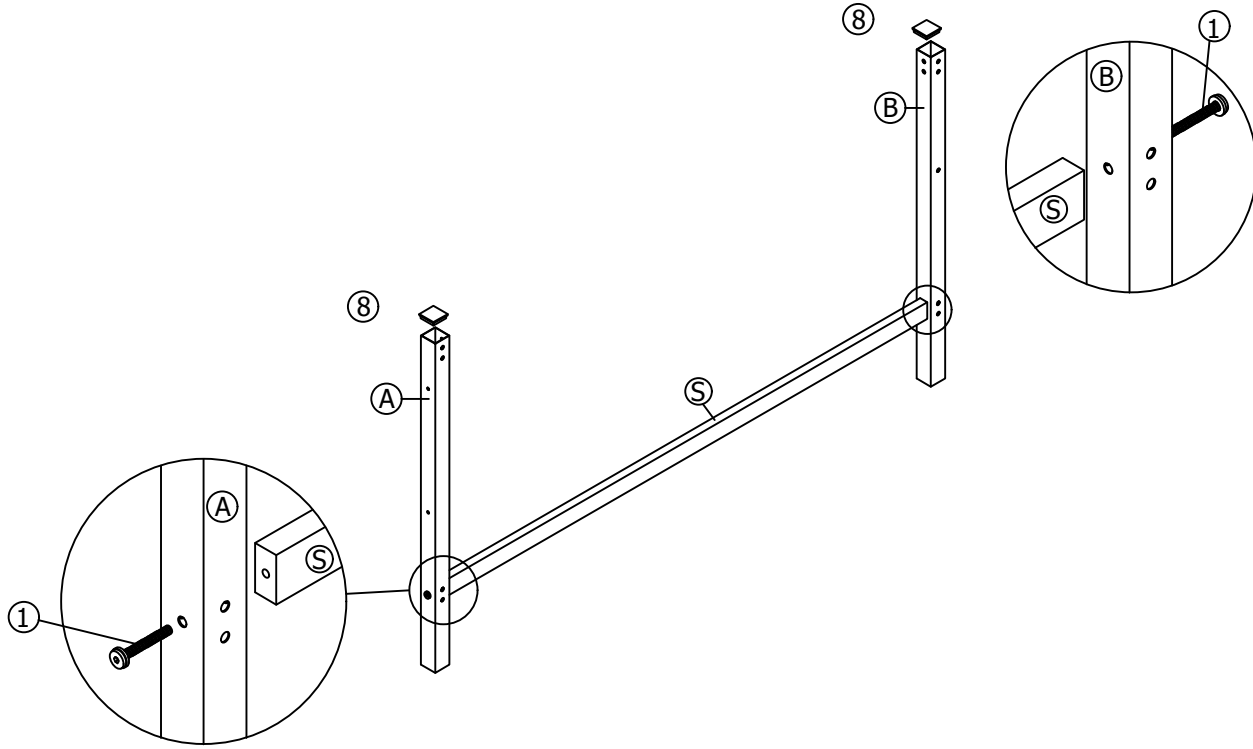

Hardware/Matériel		
Code	Image	Qty/Qte
1		2 pcs
8		2 pcs

STEP 1-2 / ÉTAPE 1-2

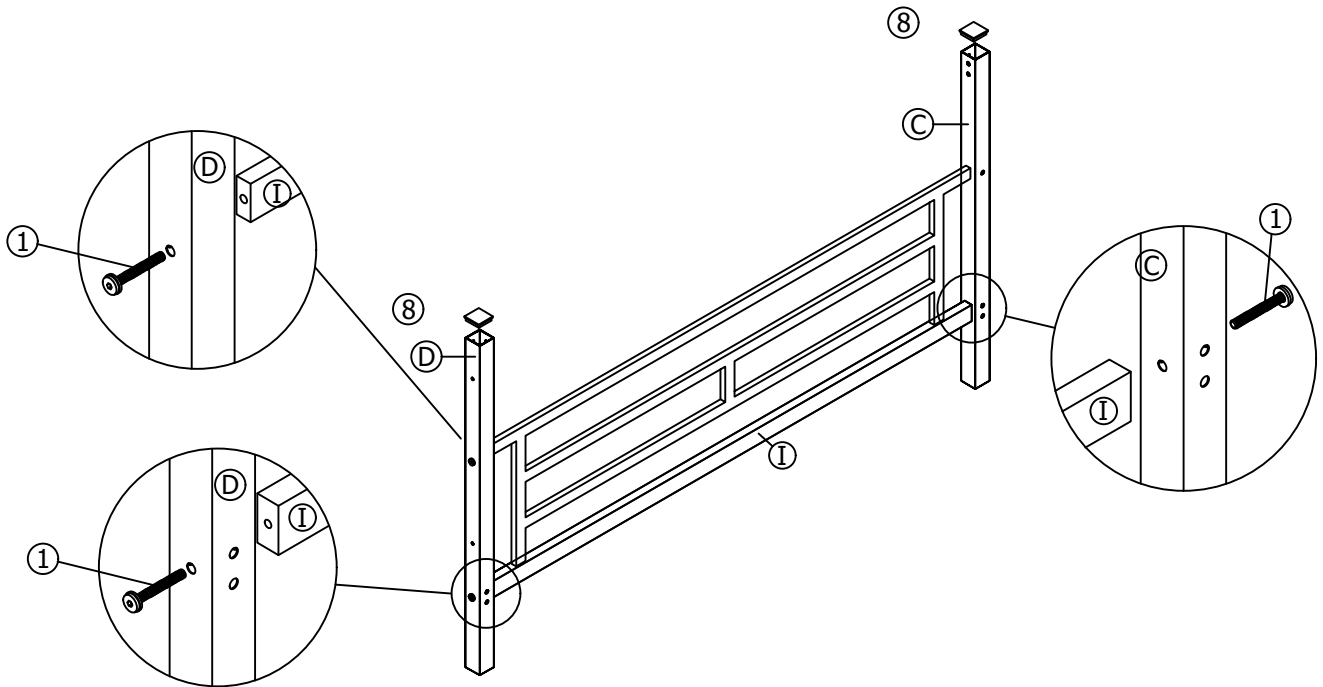

Hardware/Matériel		
Code	Image	Qty/Qte
1		4 pcs
8		2 pcs

STEP 1-3 / ÉTAPE 1-3

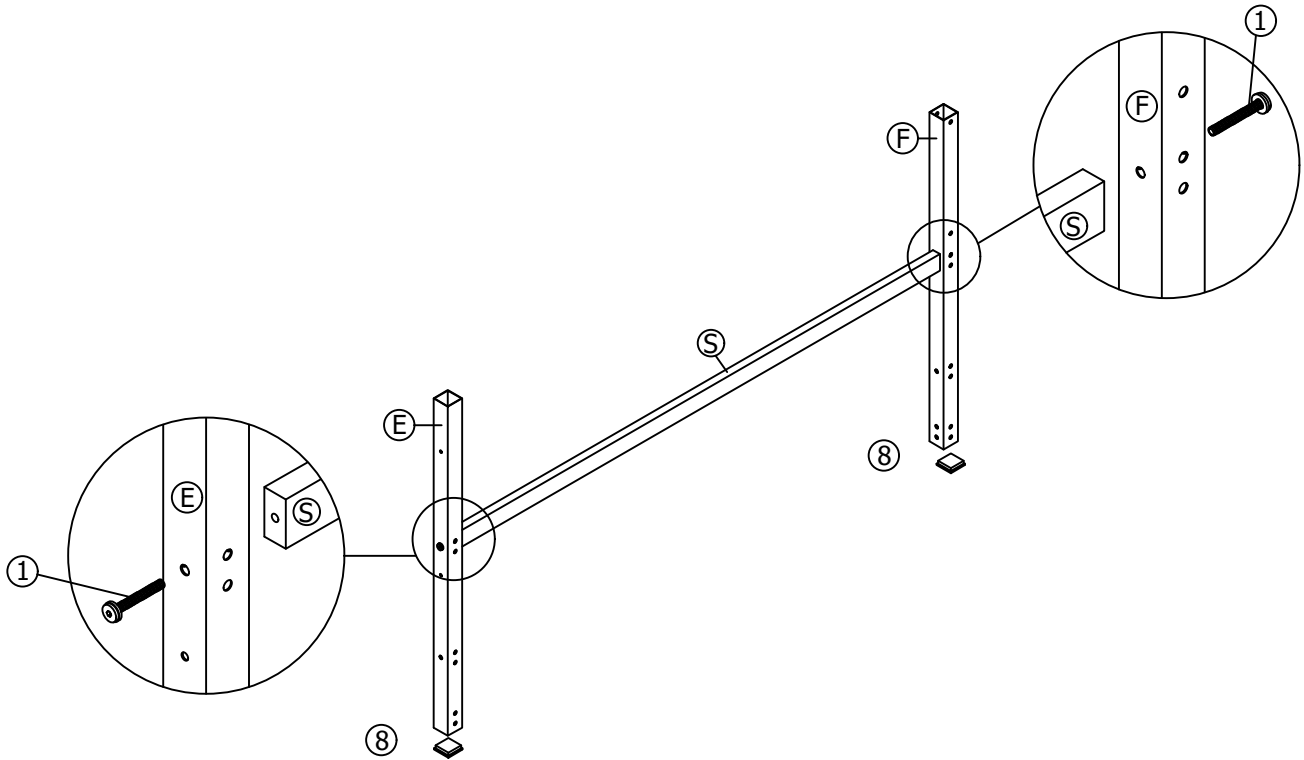

Hardware/Matériel		
Code	Image	Qty/Qte
1		2 pcs
8		2 pcs

STEP 1-4 / ÉTAPE 1-4

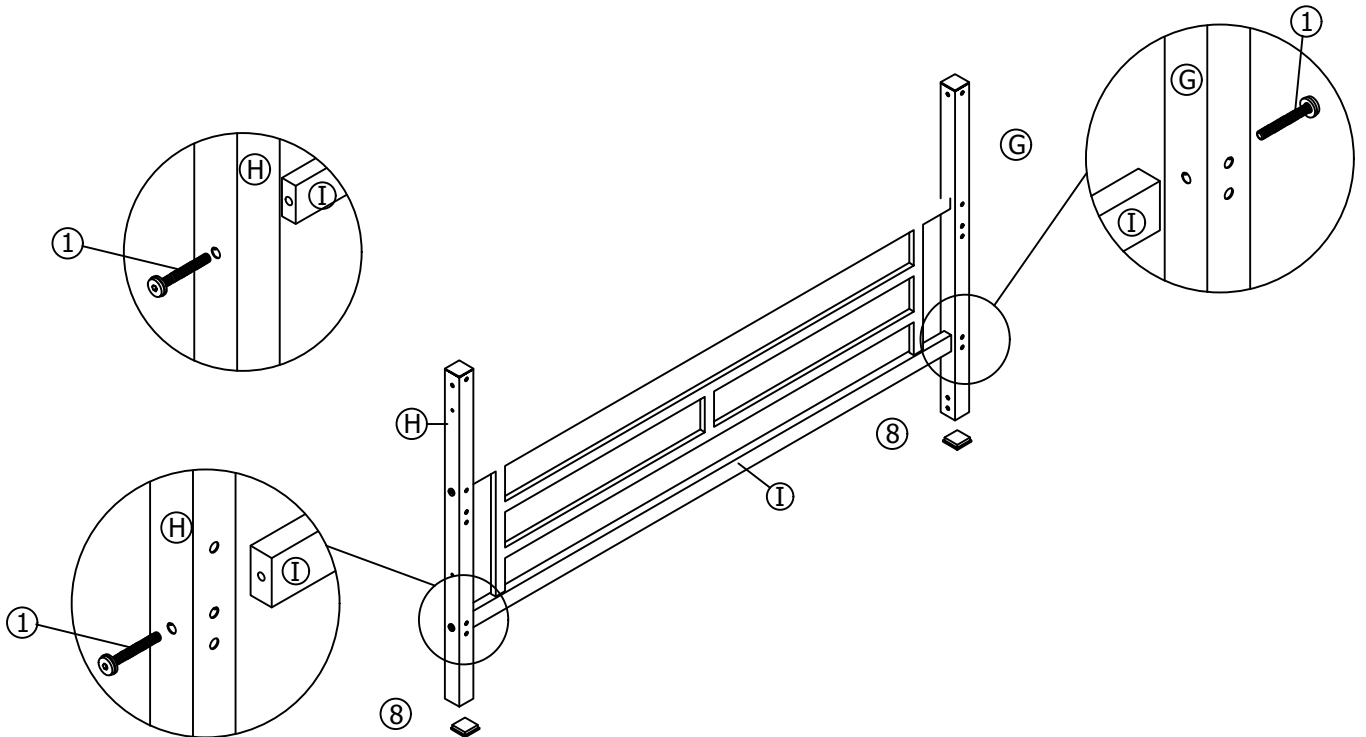

Hardware/Matériel		
Code	Image	Qty/Qte
1		4 pcs
8		2 pcs

STEP 2-1 / ÉTAPE 2-1

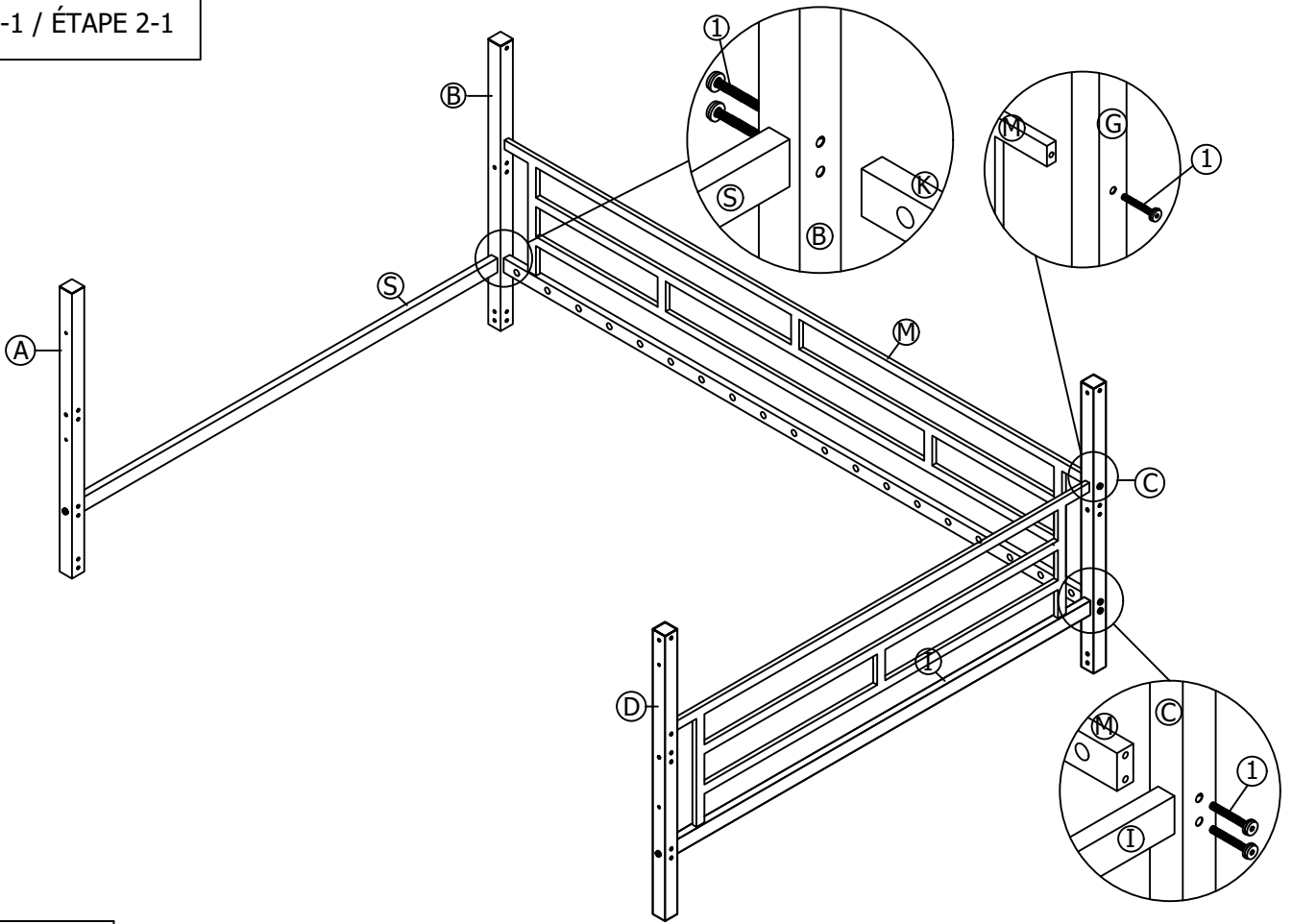

Hardware/Matériel		
Code	Image	Qty/Qte
1		6 pcs

STEP 2-2 / ÉTAPE 2-2

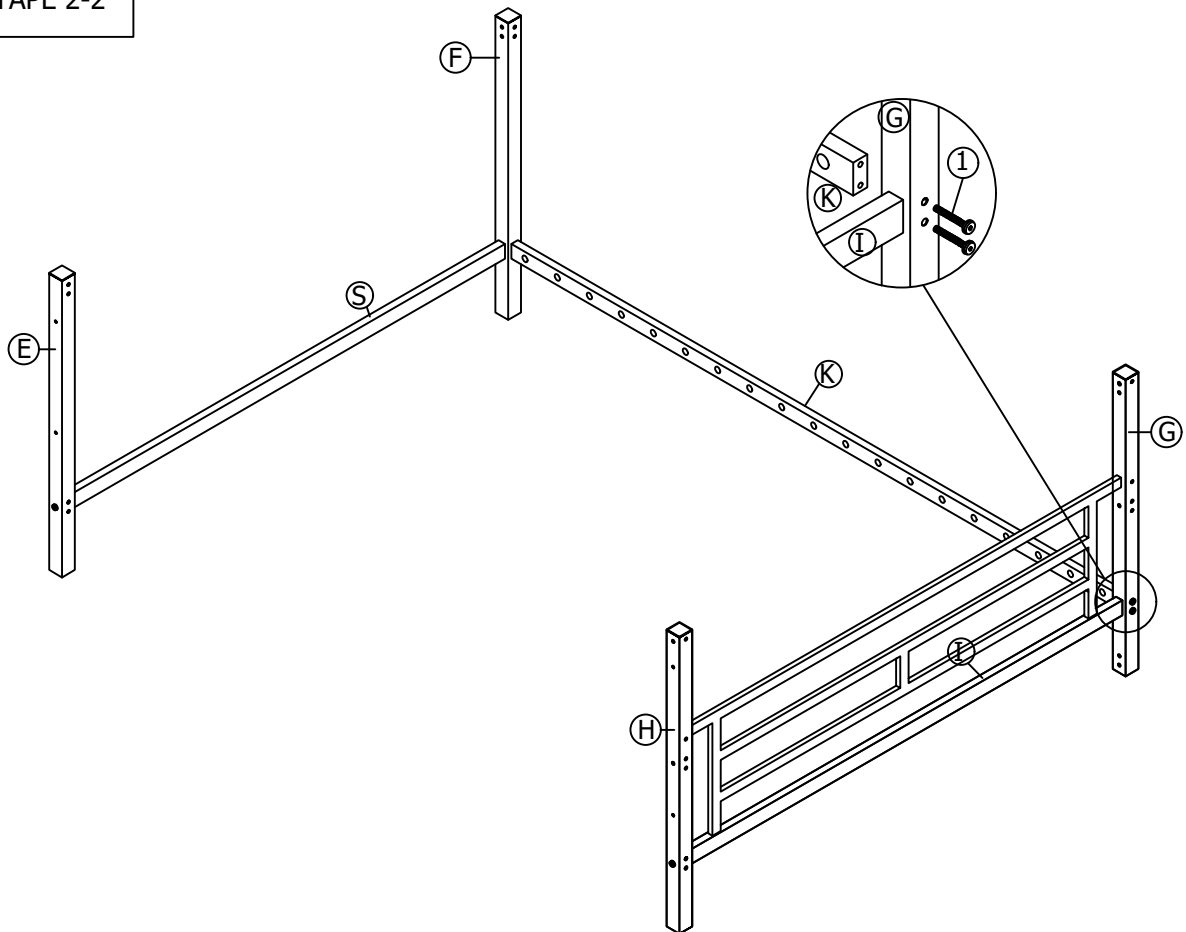

Hardware/Matériel		
Code	Image	Qty/Qte
1		4 pcs

STEP 3-1 / ÉTAPE 3-1

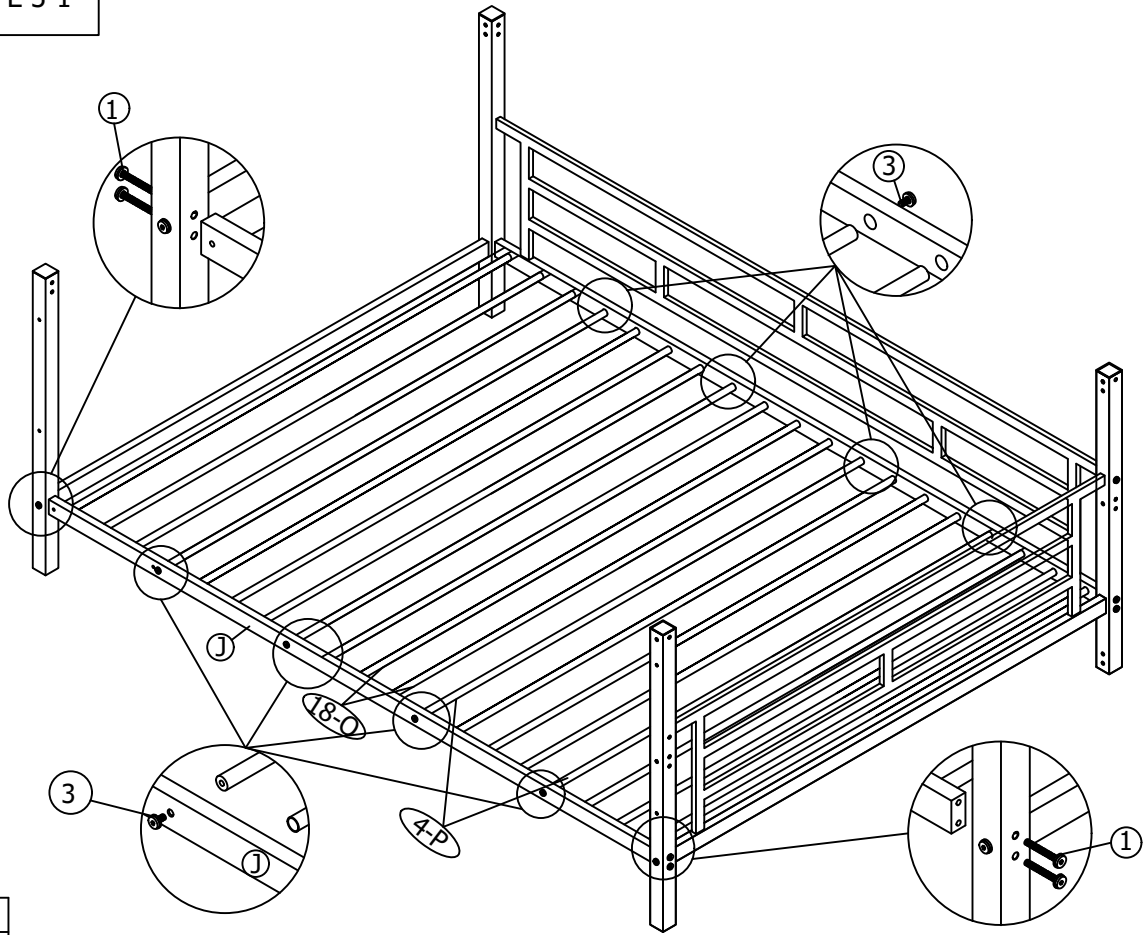

Hardware/Matériel		
Code	Image	Qty/Qte
1		4 pcs
3		8 pcs

STEP 3-2 / ÉTAPE 3-2

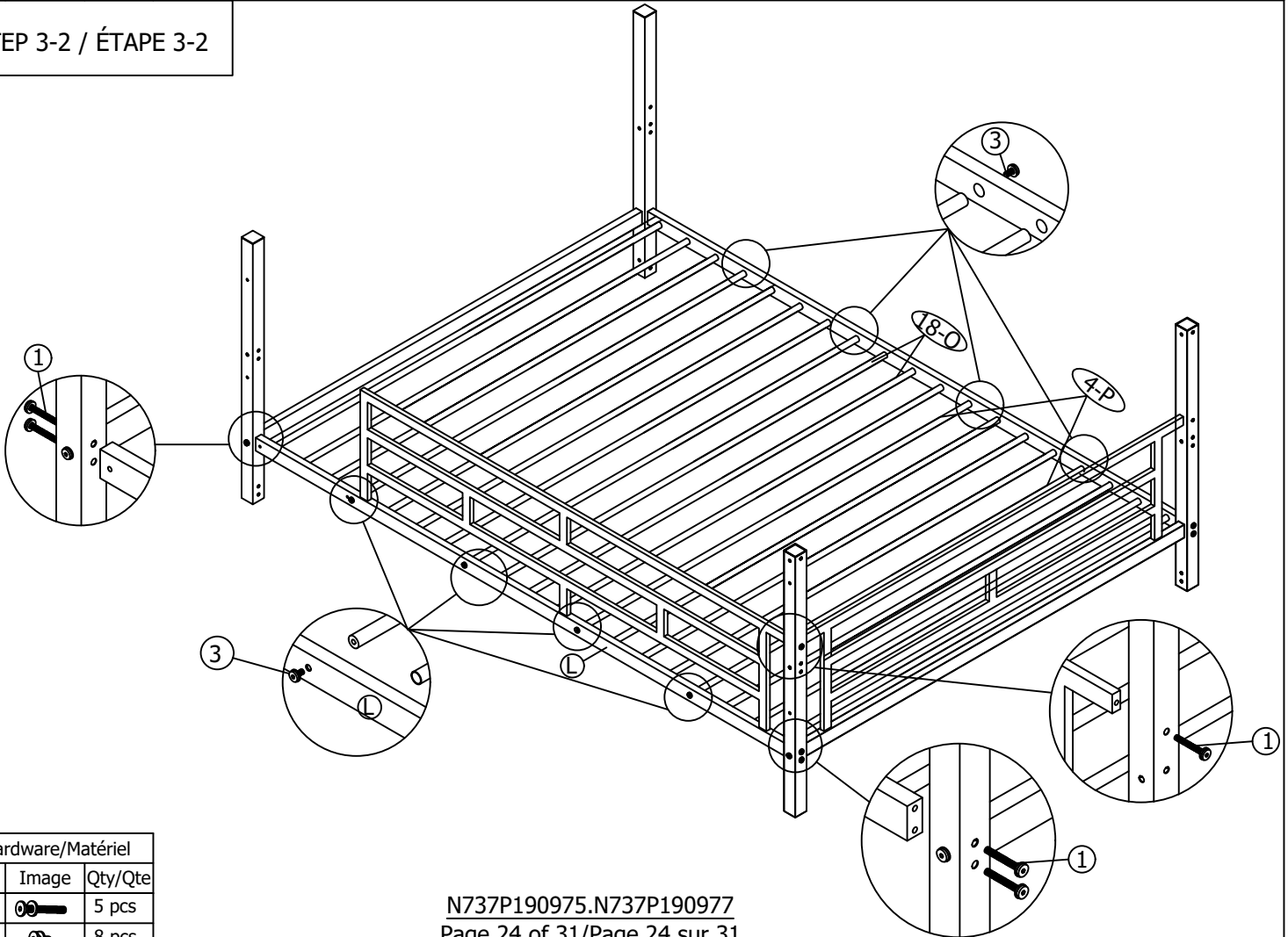

Hardware/Matériel		
Code	Image	Qty/Qte
1		5 pcs
3		8 pcs

STEP 4-1 / ÉTAPE 4-1

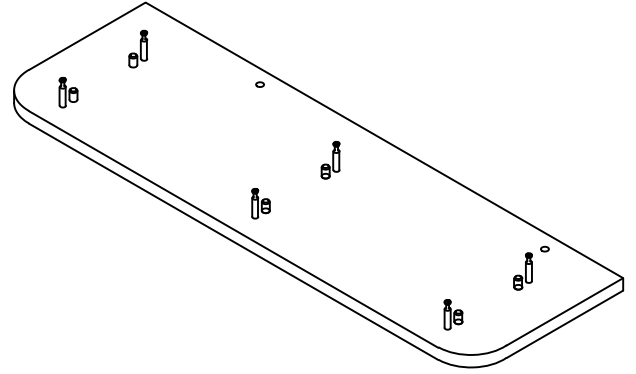
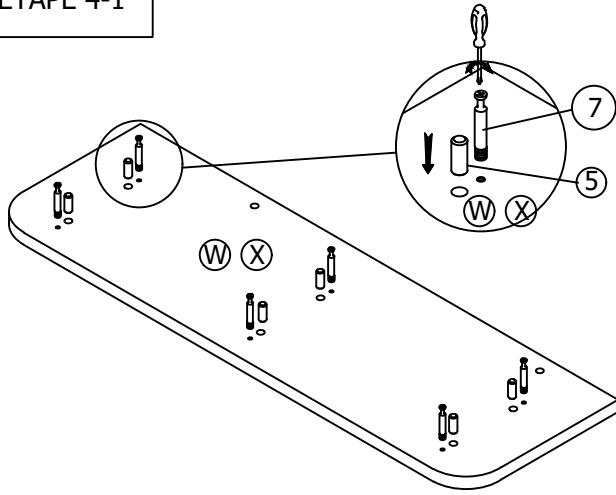

Hardware/Matériel		
Code	Image	Qty/Qte
5		24 pcs
7		24 pcs

QTY/QTE: 04

STEP 4-2 / ÉTAPE 4-2

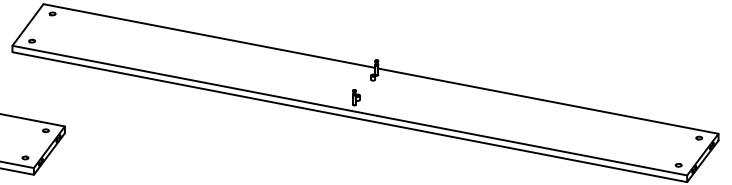
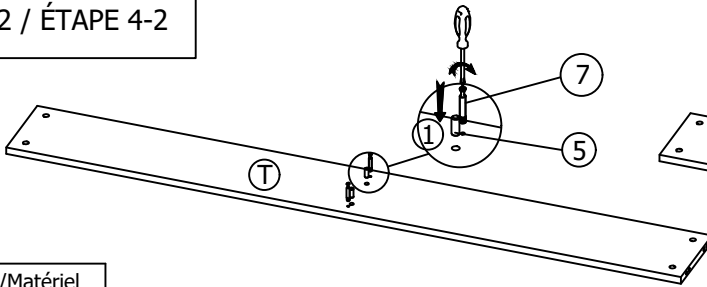

Hardware/Matériel		
Code	Image	Qty/Qte
5		4 pcs
7		4 pcs

QTY/QTE: 02

STEP 4-3 / ÉTAPE 4-3

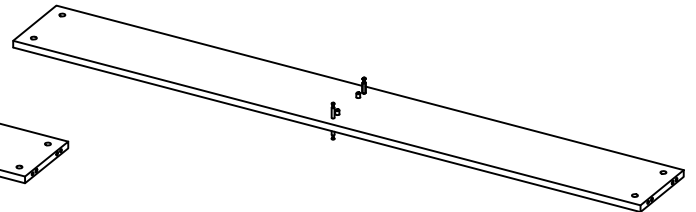
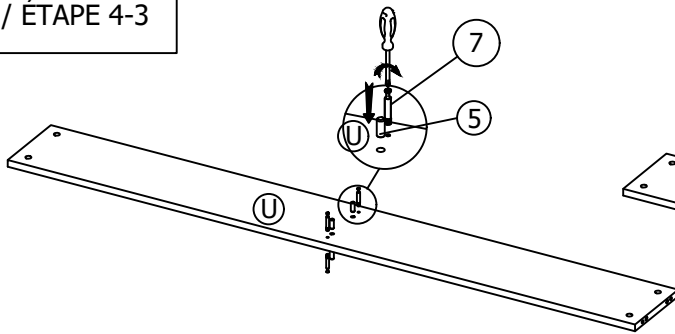

Hardware/Matériel		
Code	Image	Qty/Qte
		8 pcs
		8 pcs

QTY/QTE: 02

STEP 4-4 / ÉTAPE 4-4

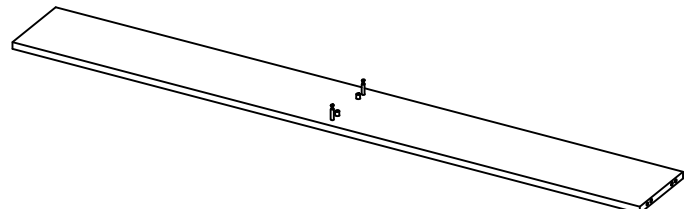
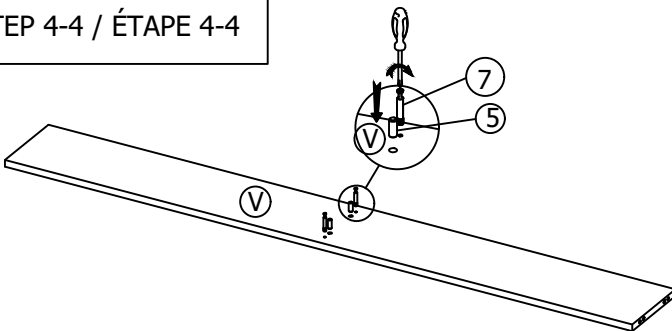

Hardware/Matériel		
Code	Image	Qty/Qte
5		4 pcs
7		4 pcs

STEP 5-1 / ÉTAPE 5-1

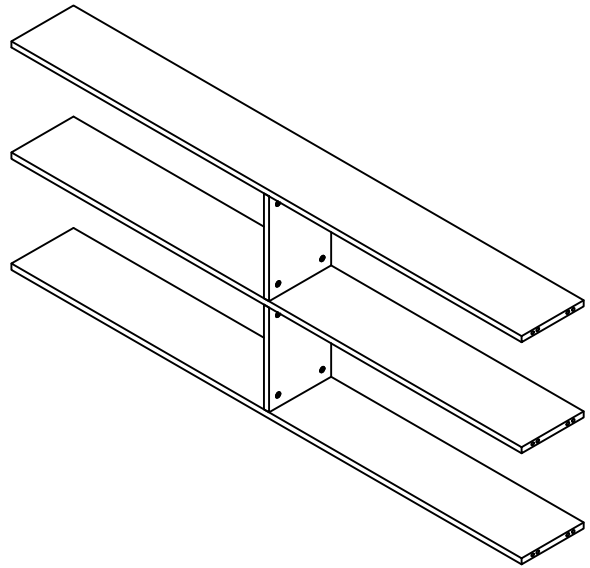
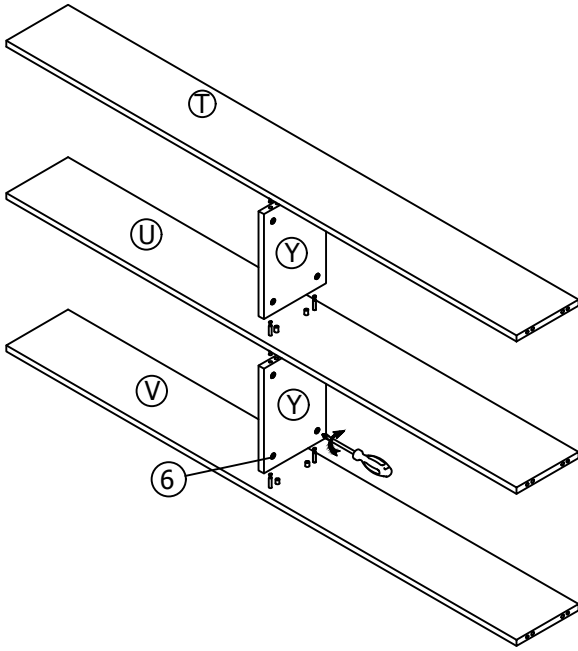

QTY/QTE: 02

Hardware/Matériel		
Code	Image	Qty/Qte
6		16 pcs

STEP 5-2 / ÉTAPE 5-2

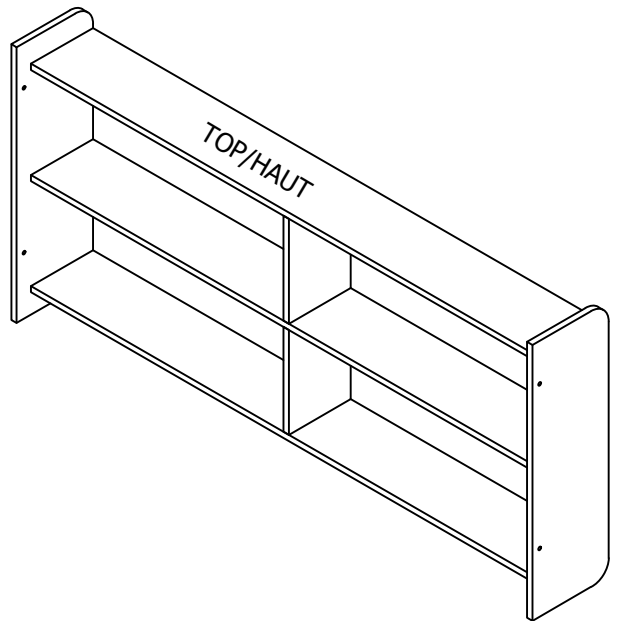
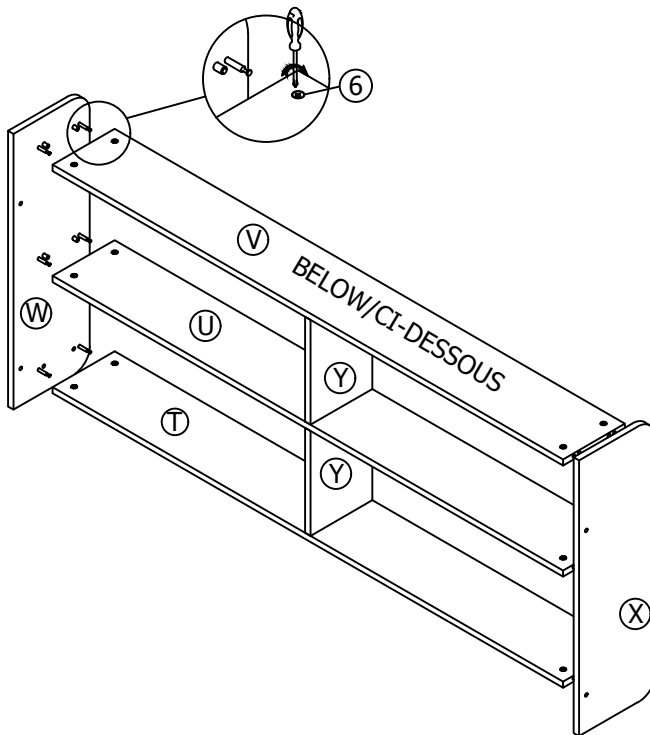

QTY/QTE: 02

Hardware/Matériel		
Code	Image	Qty/Qte
6		24 pcs

STEP 6-1 / ÉTAPE 6-1

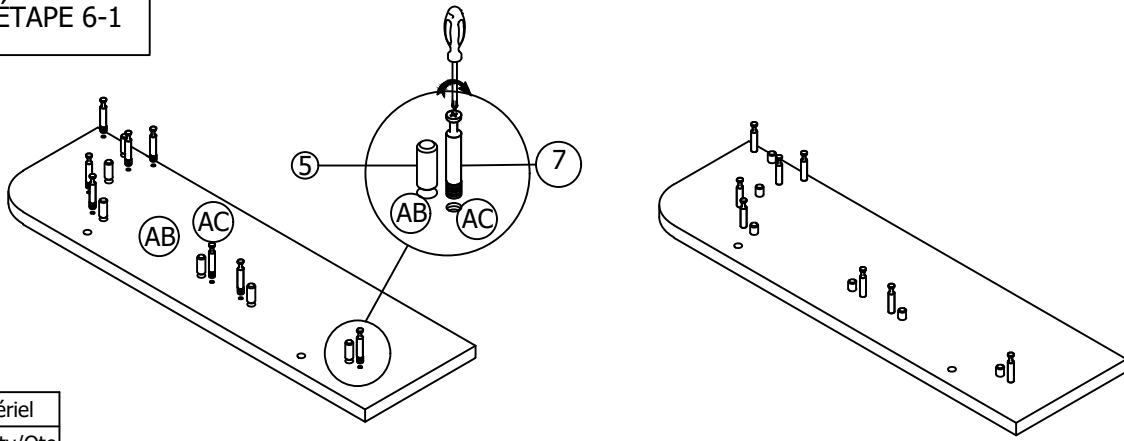

Hardware/Matériel		
Code	Image	Qty/Qte
5		24 pcs
7		32 pcs

QTY/QTE: 04

STEP 6-2 / ÉTAPE 6-2

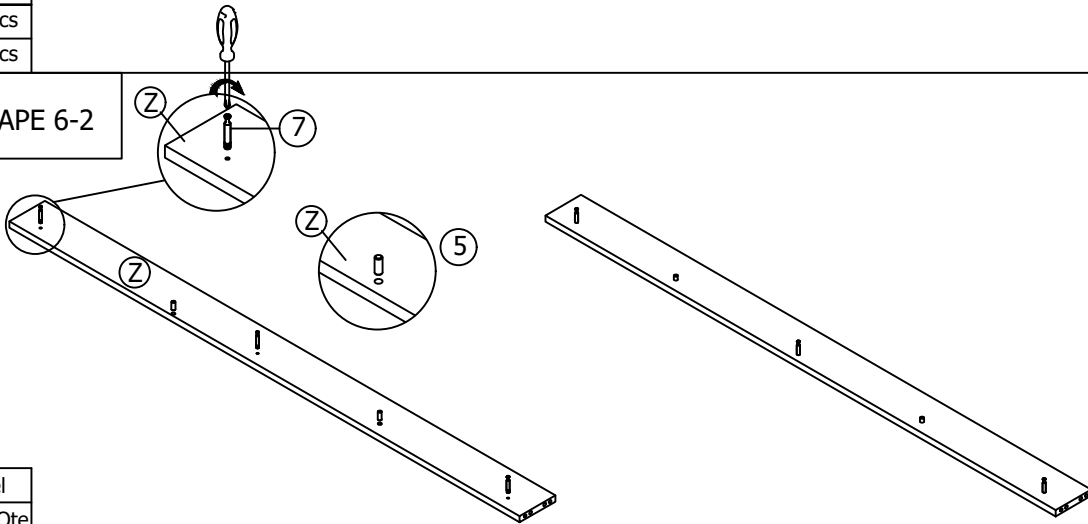

Hardware/Matériel		
Code	Image	Qty/Qte
5		4 pcs
7		6 pcs

QTY/QTE: 02

STEP 6-3 / ÉTAPE 6-3

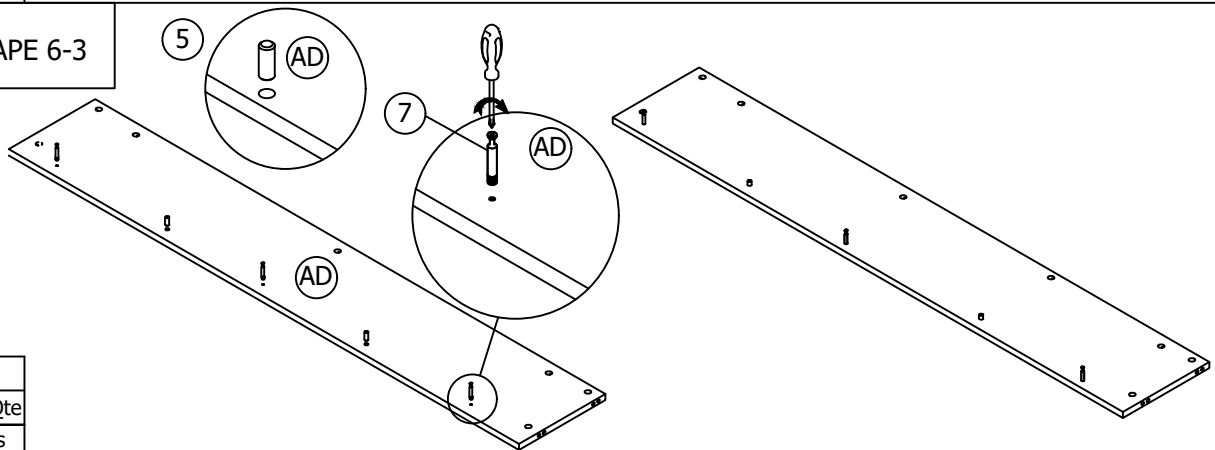

Hardware/Matériel		
Code	Image	Qty/Qte
5		4 pcs
7		6 pcs

QTY/QTE: 02

STEP 6-4 / ÉTAPE 6-4

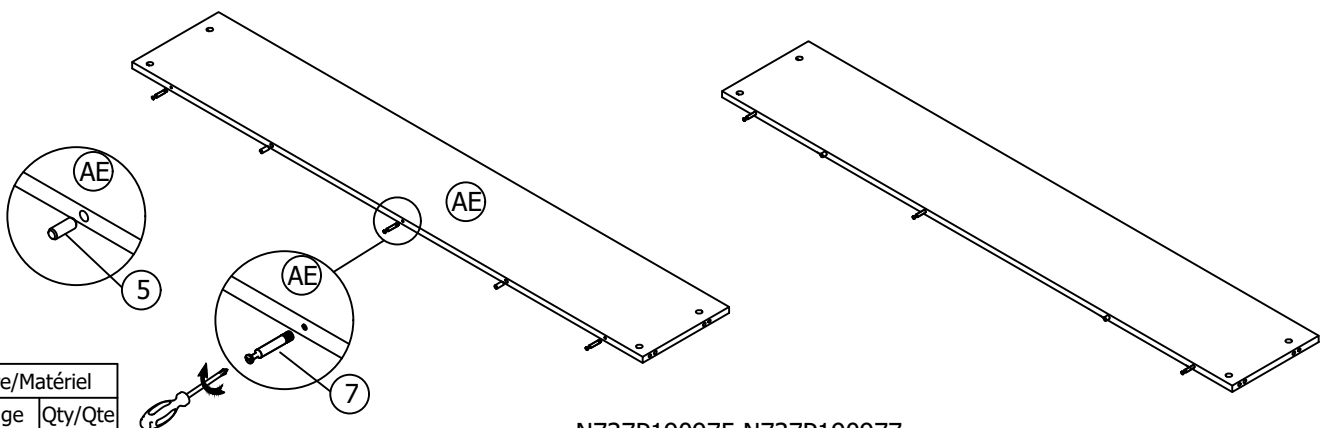

Hardware/Matériel		
Code	Image	Qty/Qte
5		4 pcs
7		6 pcs

QTY/QTE: 02

STEP 7-1 / ÉTAPE 7-1

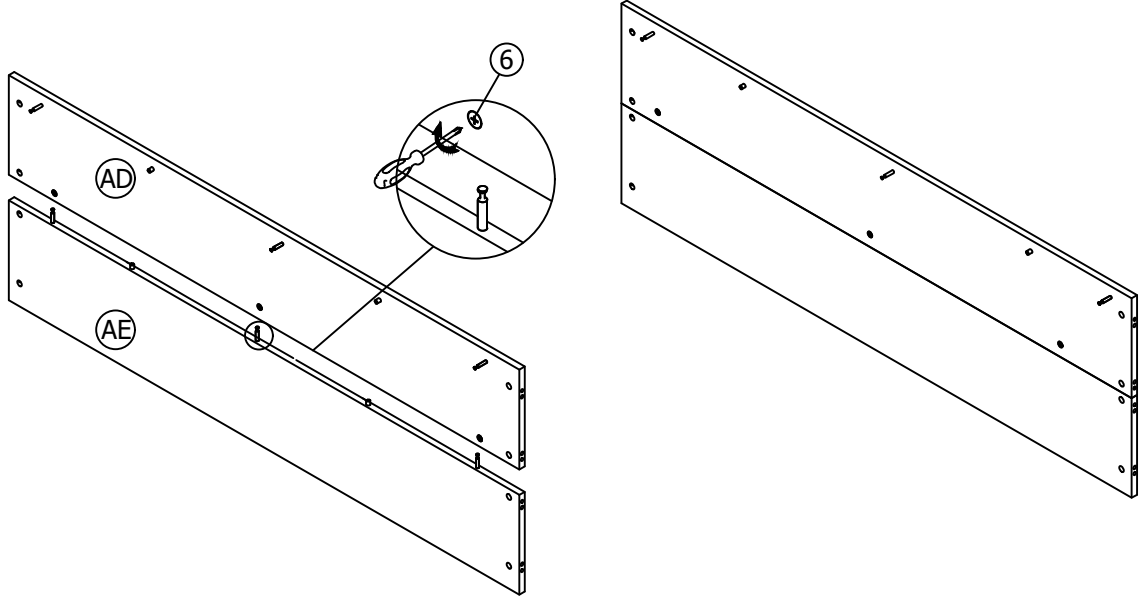

Hardware/Matériel		
Code	Image	Qty/Qte
6		6 pcs

QTY/QTE: 02

STEP 7--2 / ÉTAPE 7-2

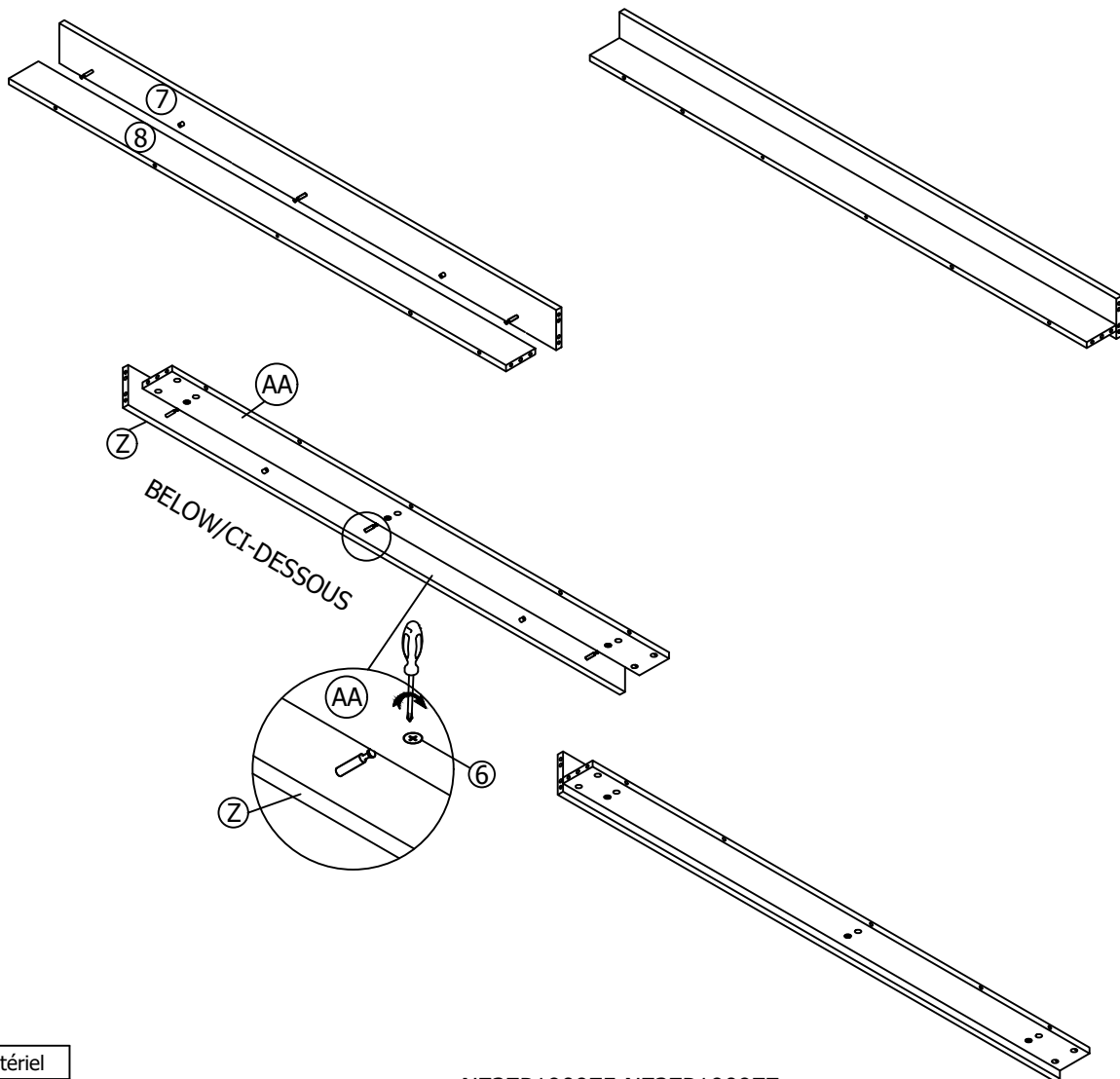

Hardware/Matériel		
Code	Image	Qty/Qte
6		6 pcs

QTY/QTE: 02

STEP 8 / ÉTAPE 8

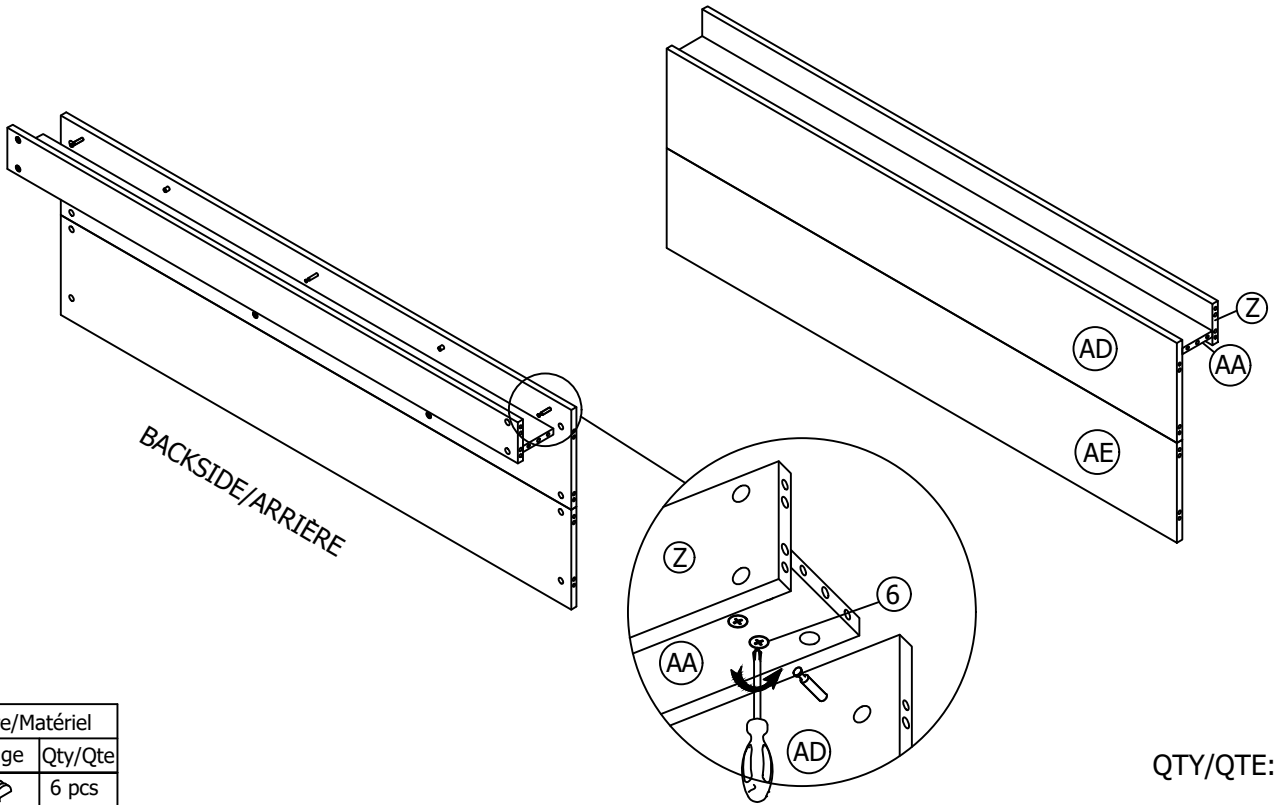

Hardware/Matériel		
Code	Image	Qty/Qte
6		6 pcs

QTY/QTE: 02

STEP 9 / ÉTAPE 9

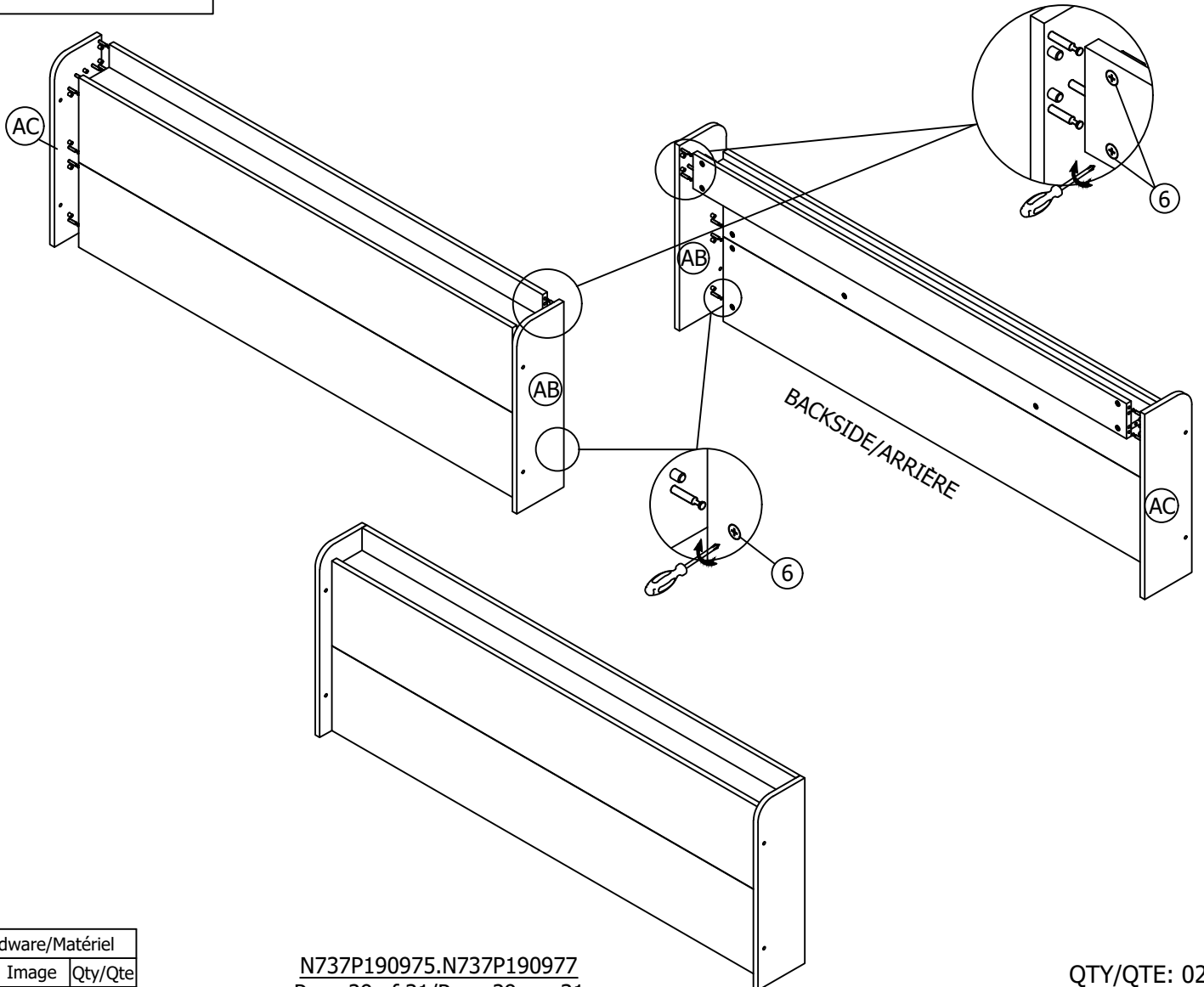

Hardware/Matériel		
Code	Image	Qty/Qte
6		32 pcs

QTY/QTE: 02

STEP 10 / ÉTAPE 10

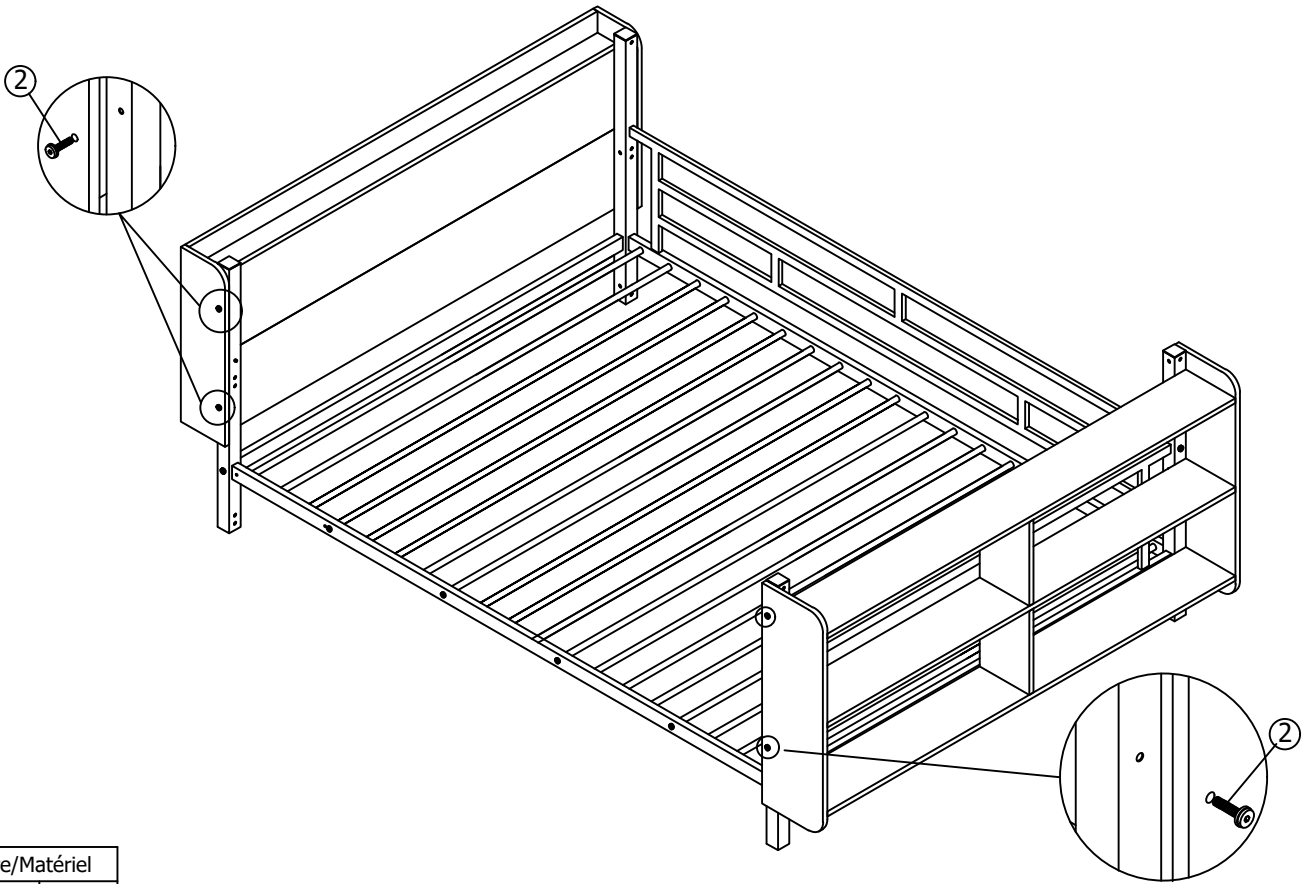

Hardware/Matériel		
Code	Image	Qty/Qte
2		8 pcs

STEP 11 / ÉTAPE 11

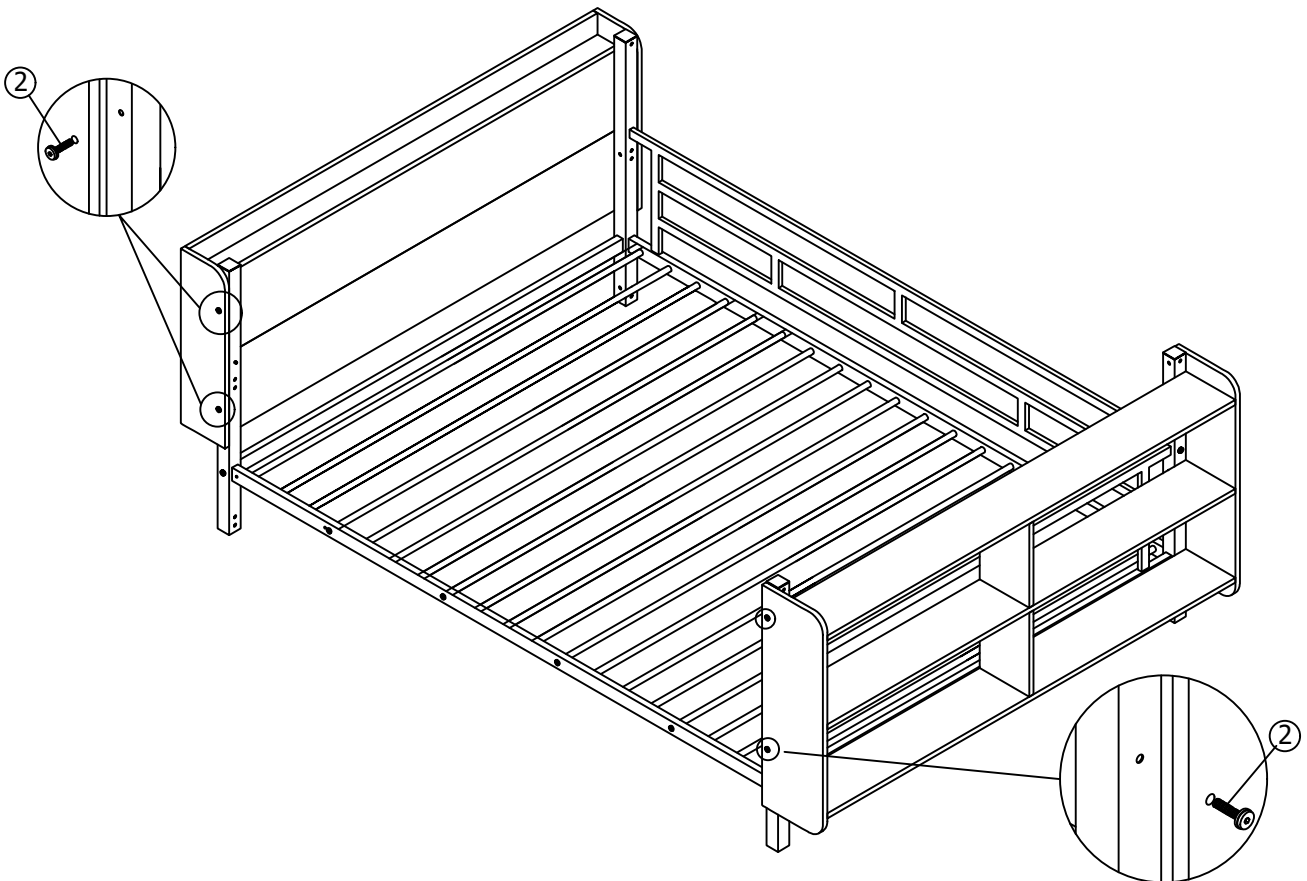

Hardware/Matériel		
Code	Image	Qty/Qte
2		8 pcs

FINISH/FINITION

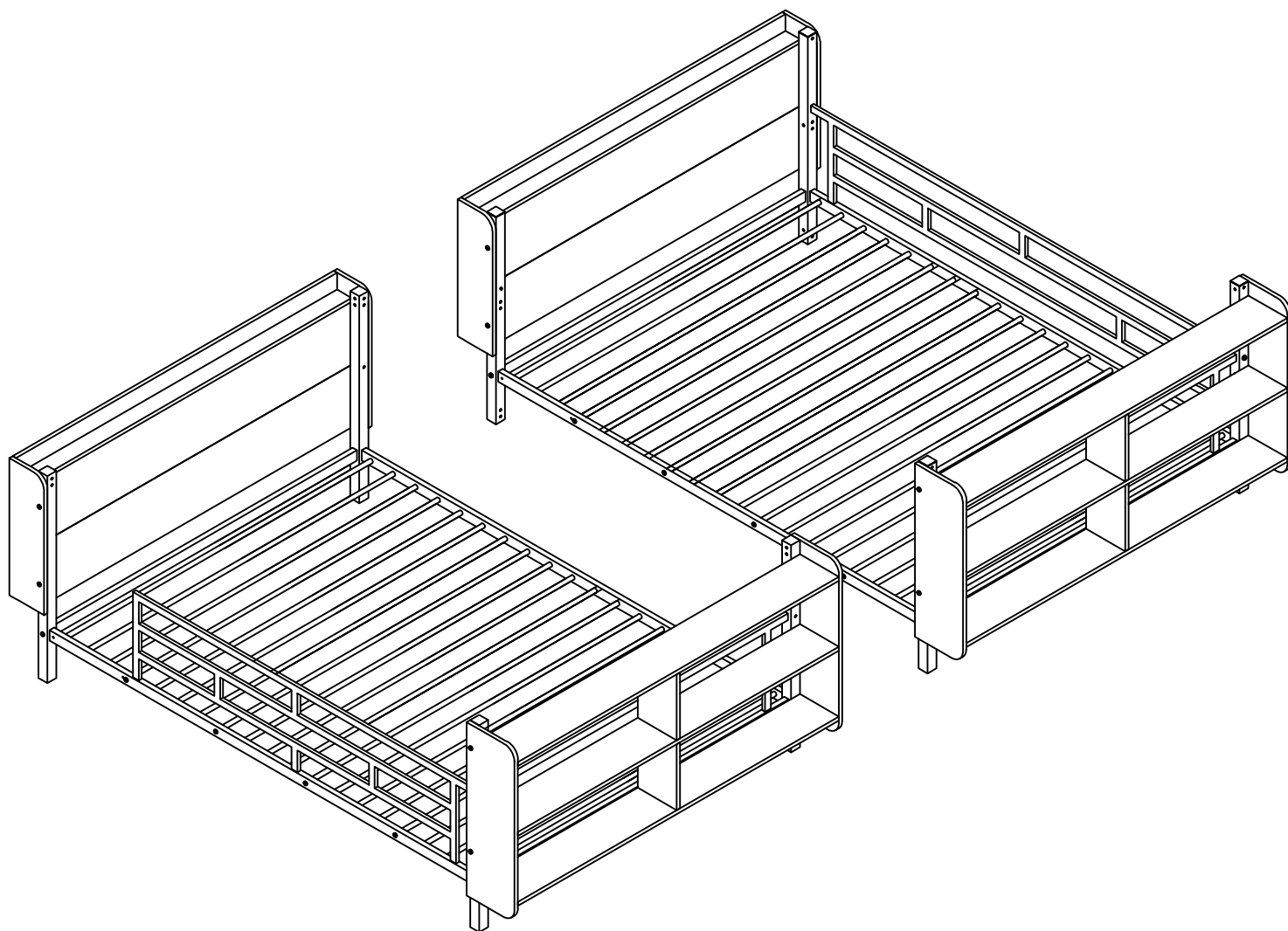

TWIN BED WITH 2 BOOKSHELFS / LIT DOUBLE SUPERPOSÉ AVEC 2 ÉTAGÈRES