

Assembly Instructions

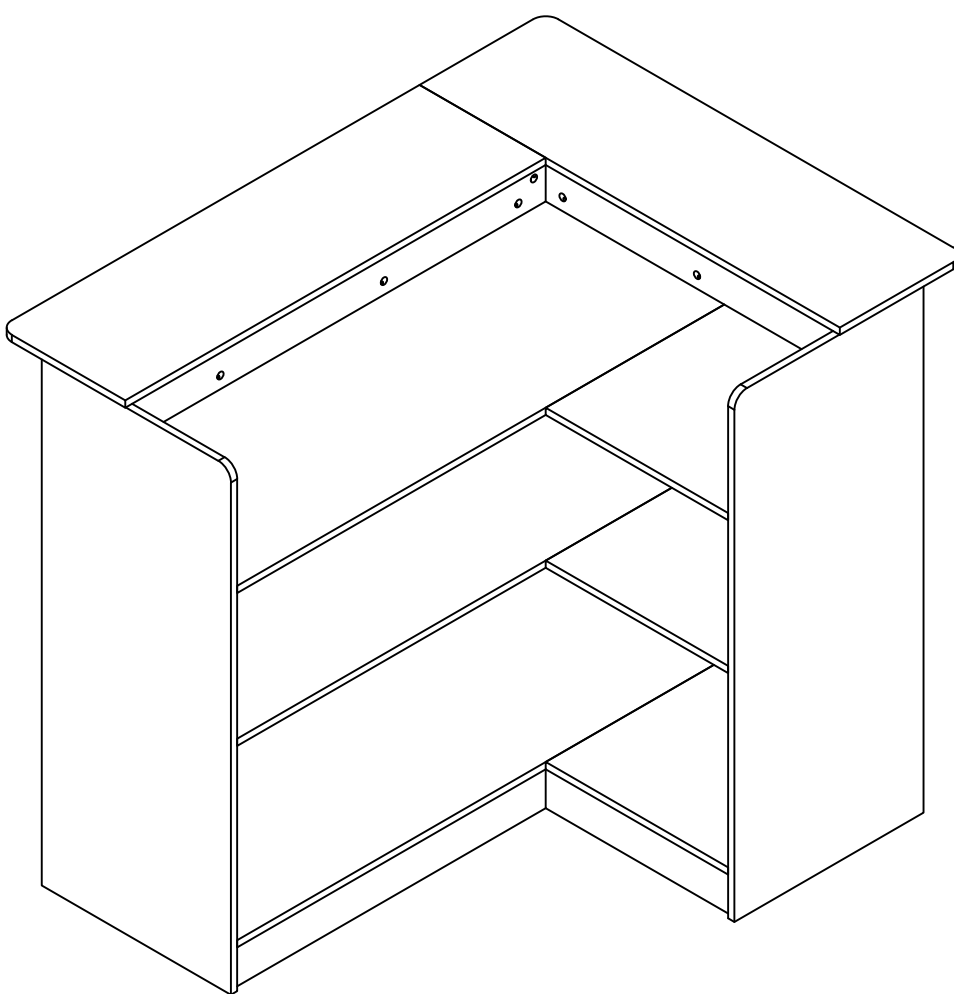

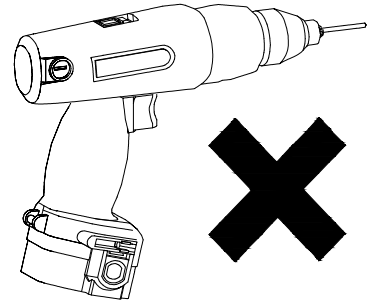
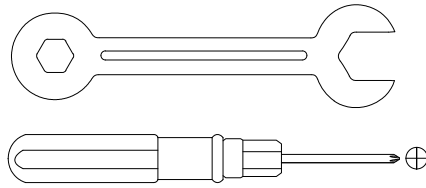
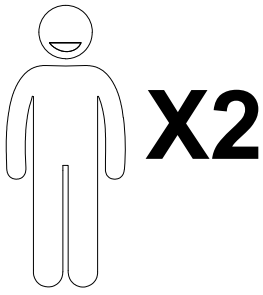

We recommend using hand tools for assembly.

If an electric screwdriver is used, reduce power and torque to avoid damage to the product.

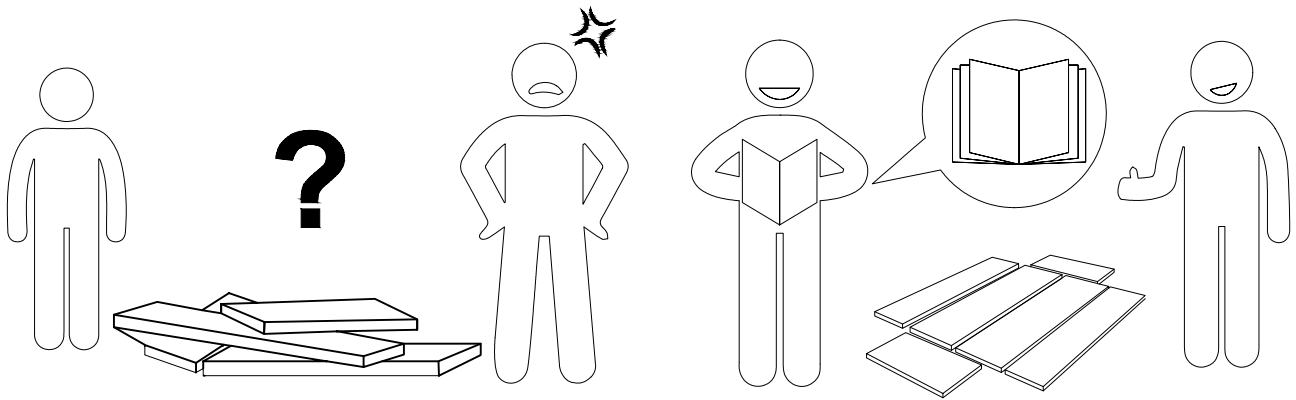

AVOID SCRATCHES

In order to avoid scratching this furniture should be assembled on a soft layer-could be a rug.

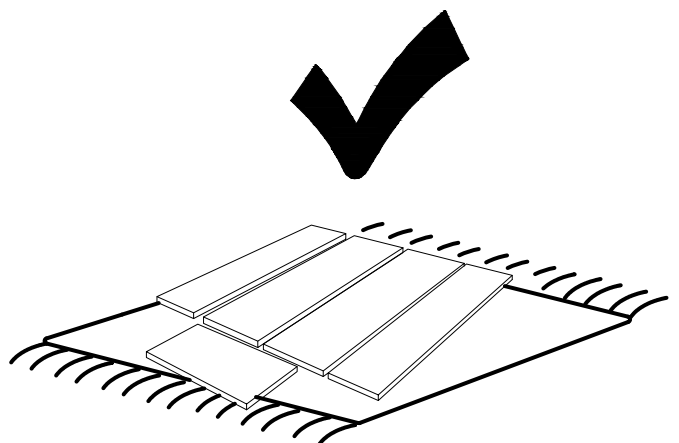
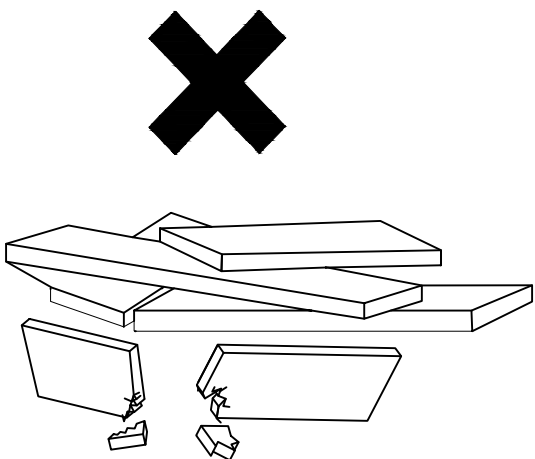

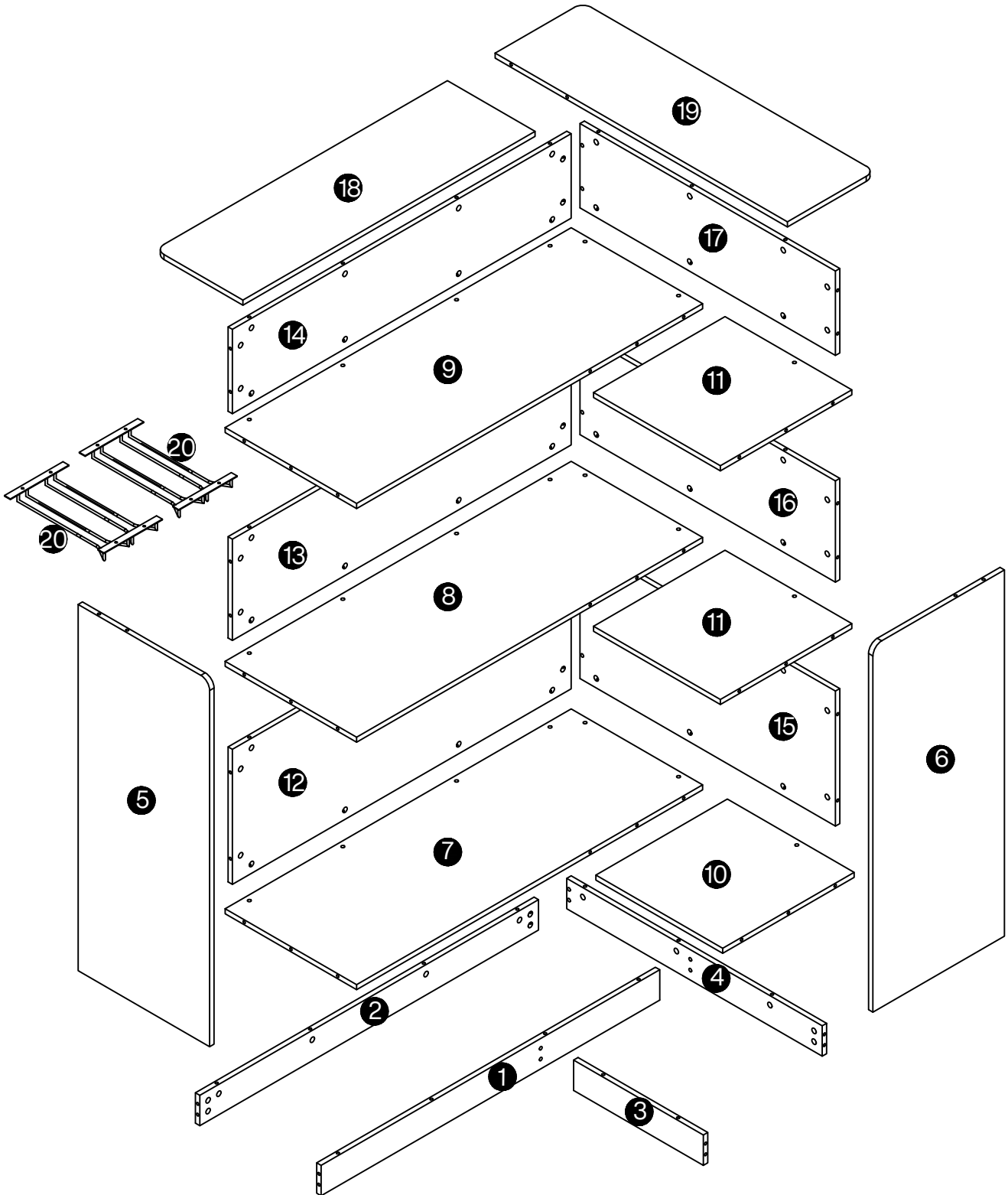



⚠ Caution

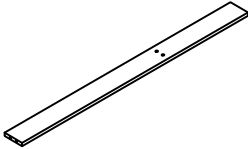
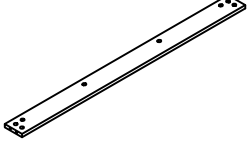
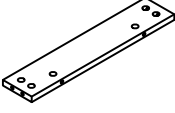
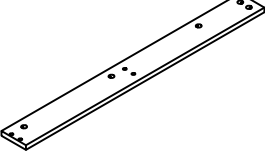
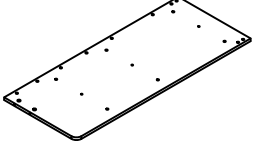
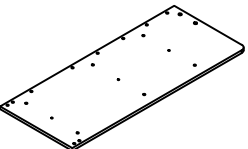
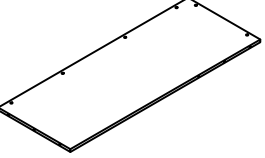
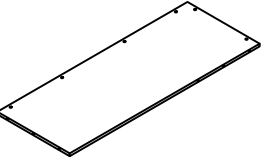
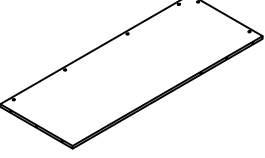
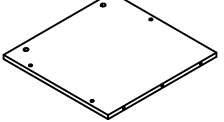
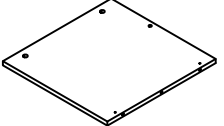
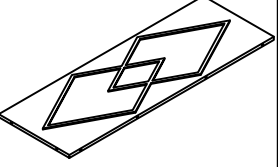
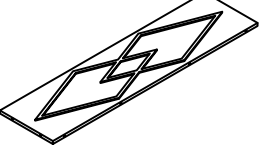
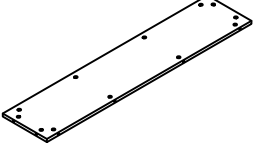
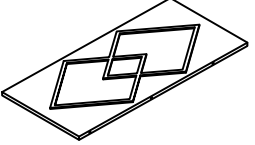
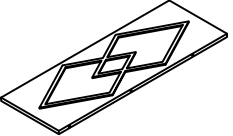
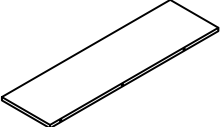
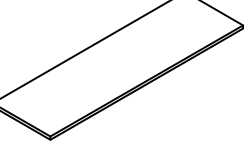
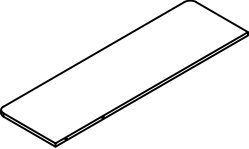
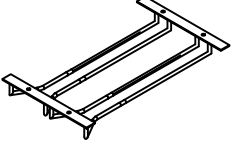

Make sure all parts are included. Most board parts are labeled or stamped on the raw edge. Contact us for a free replacement if you encounter any damaged or missing parts.

Parts List

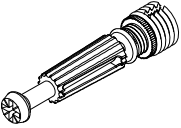
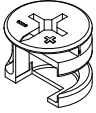
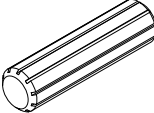
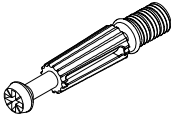
1  1 pc	2  1 pc	3  1 pc	4  1 pc	5  1 pc
6  1 pc	7  1 pc	8  1 pc	9  1 pc	10  1 pc
11  2 pcs	12  1 pc	13  1 pc	14  1 pc	15  1 pc
16  1 pc	17  1 pc	18  1 pc	19  1 pc	20  2 pcs

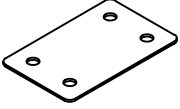
Hardware List

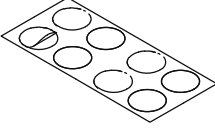
A	B	C	D	E	F
					
M6x35mm	Ø15x12mm	Ø8x30mm	M6x35mm	Ø3.5x14mm	60x38mm
61 pcs	103 pcs	17 pcs	42 pcs	28 pcs	5 pcs

G	H				
	 Ø21				
13 pcs	65 pcs	1 pc			

Installation of Cams and Pins

Screw the pin into the hole. To set the cams correctly, ensure that the arrow on the cam is opening to the hole of the pin it is locking. Lock the cam by turning the cam head with a screwdriver until it is tightened. Please do not use an electric screwdriver to assemble the unit.

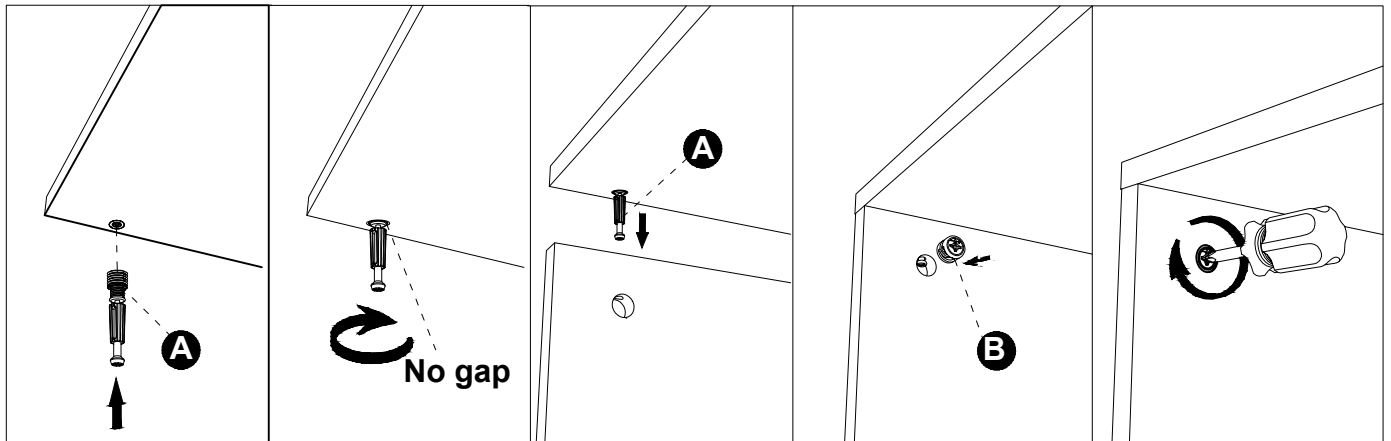

Read each step carefully before starting. It is very important that each step of instruction is performed in the correct order. If these steps are not followed in sequence, assembly difficulties will occur.

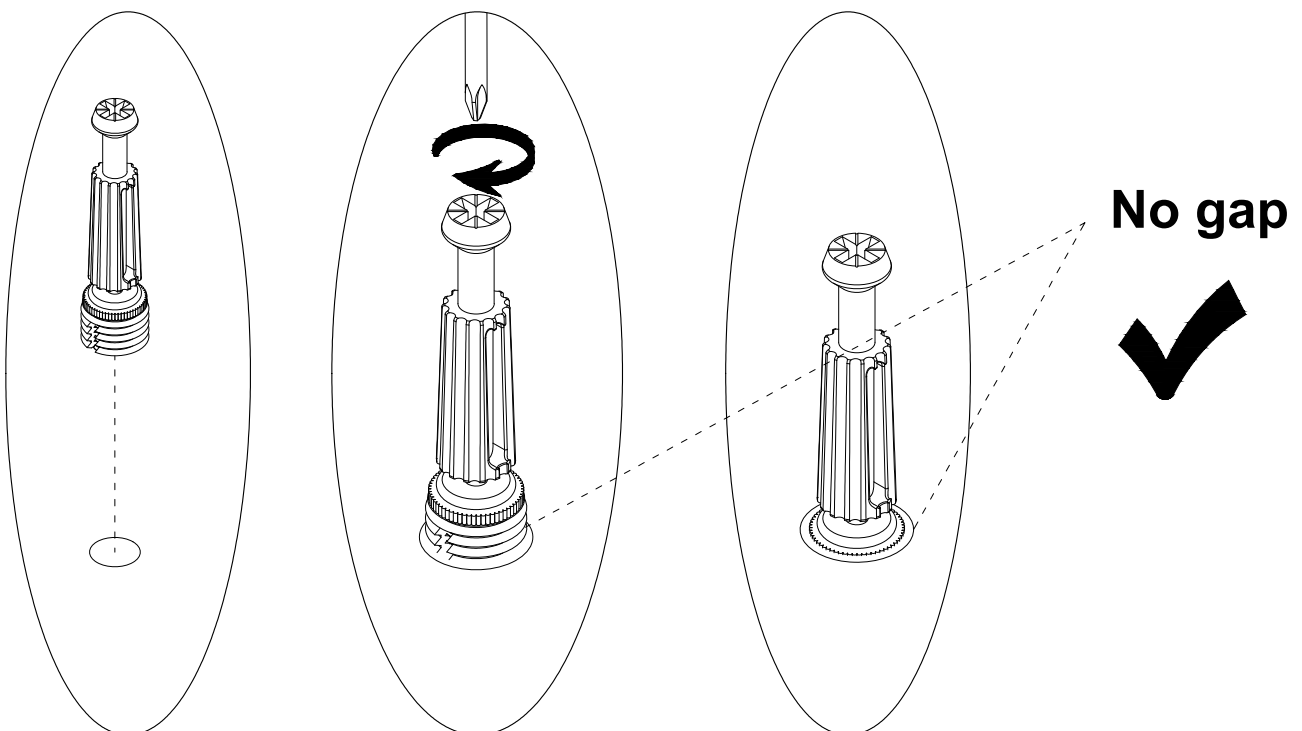

1

A

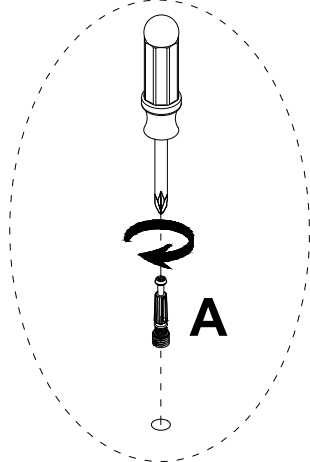
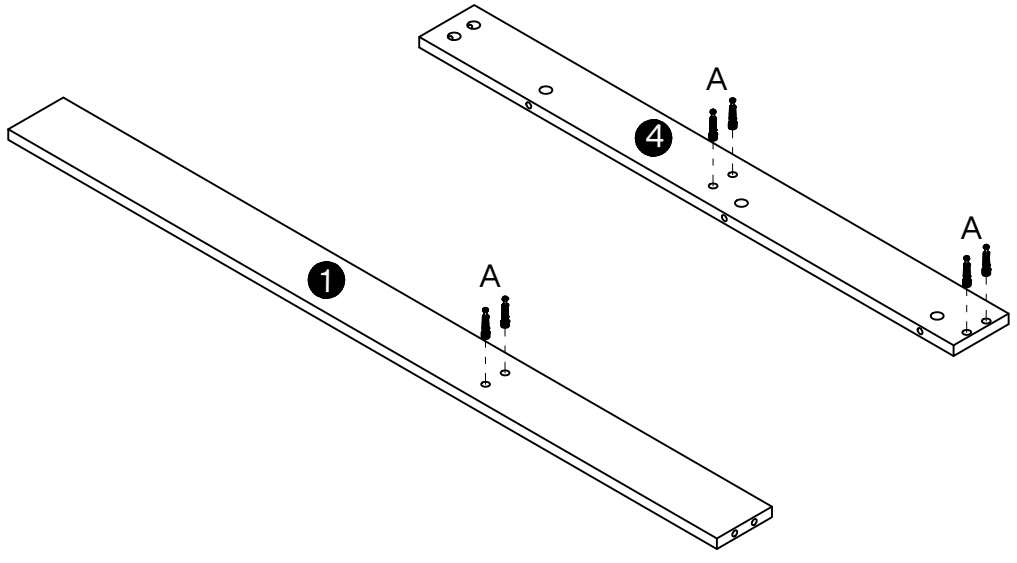
M6x35mm
6 pcs

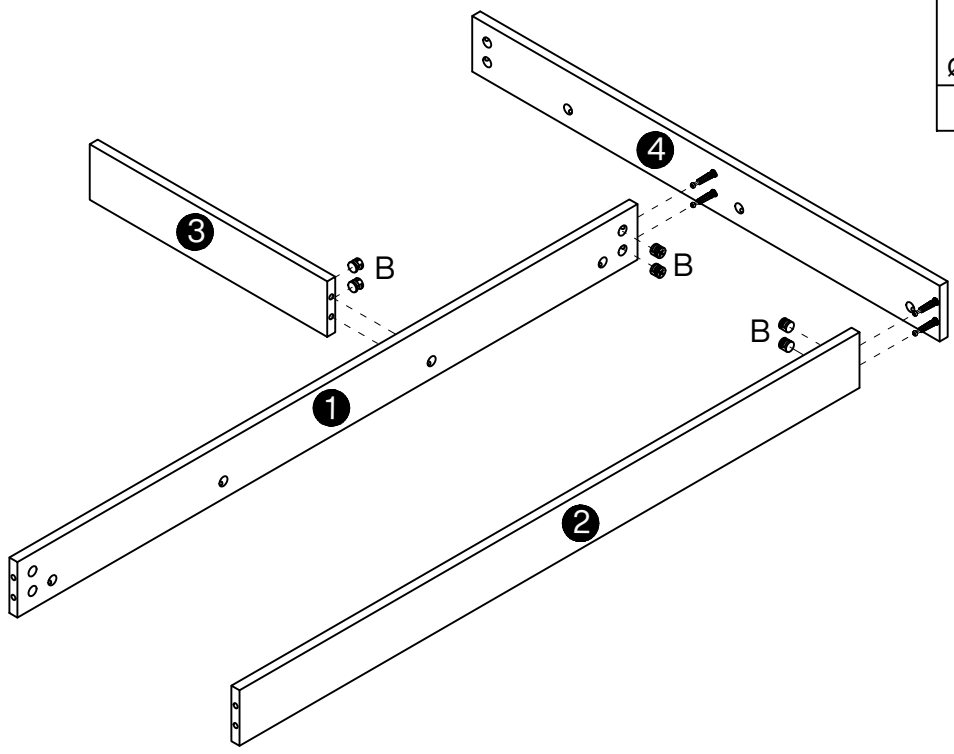
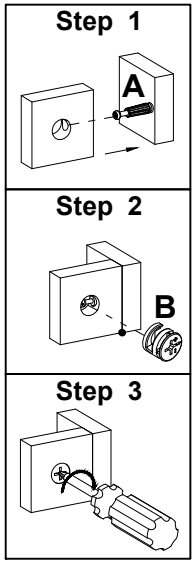

2

B

Ø15x12mm
6 pcs

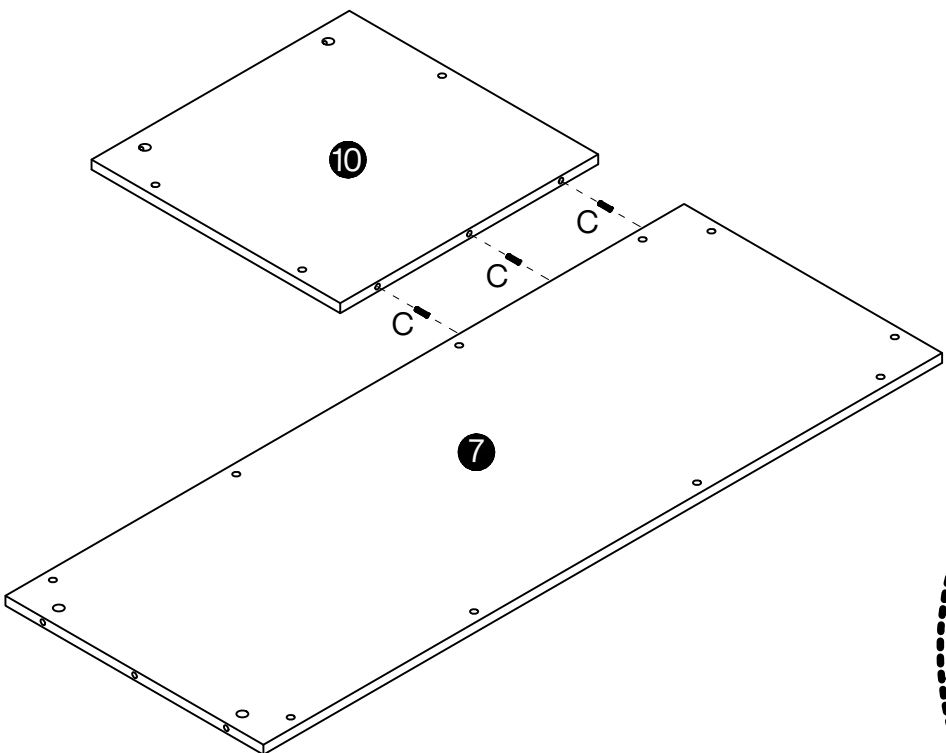

3

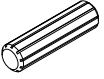

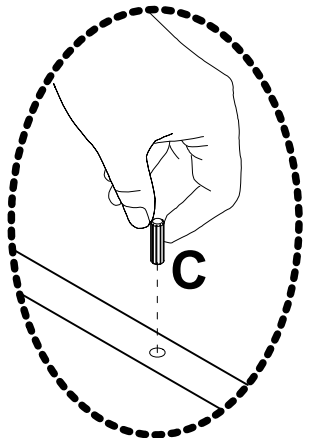

C

Ø8x30mm
3 pcs

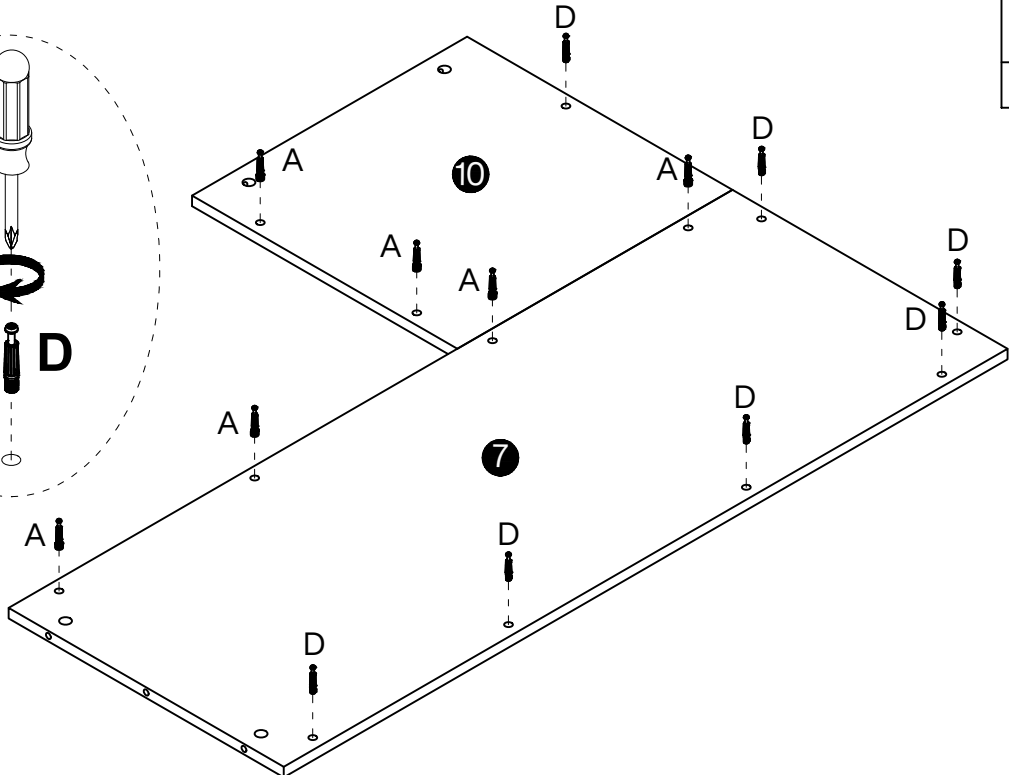

4

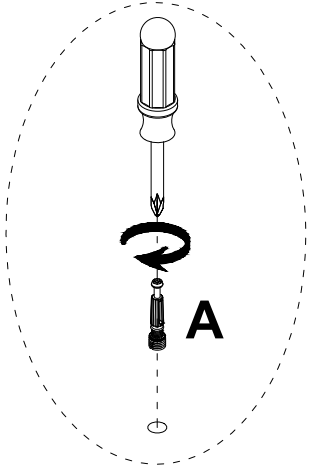
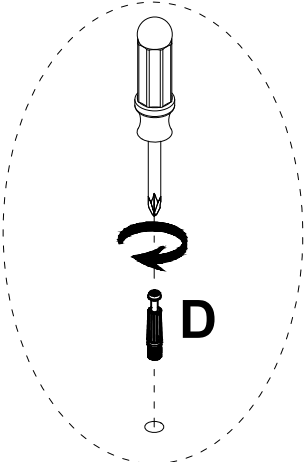

A	D
	
M6x35mm	M6x35mm
6 pcs	7 pcs



5

B

Ø15x12mm
13 pcs

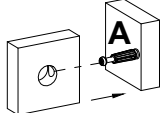
Step 1

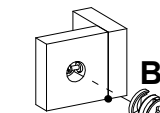

Step 2

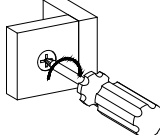
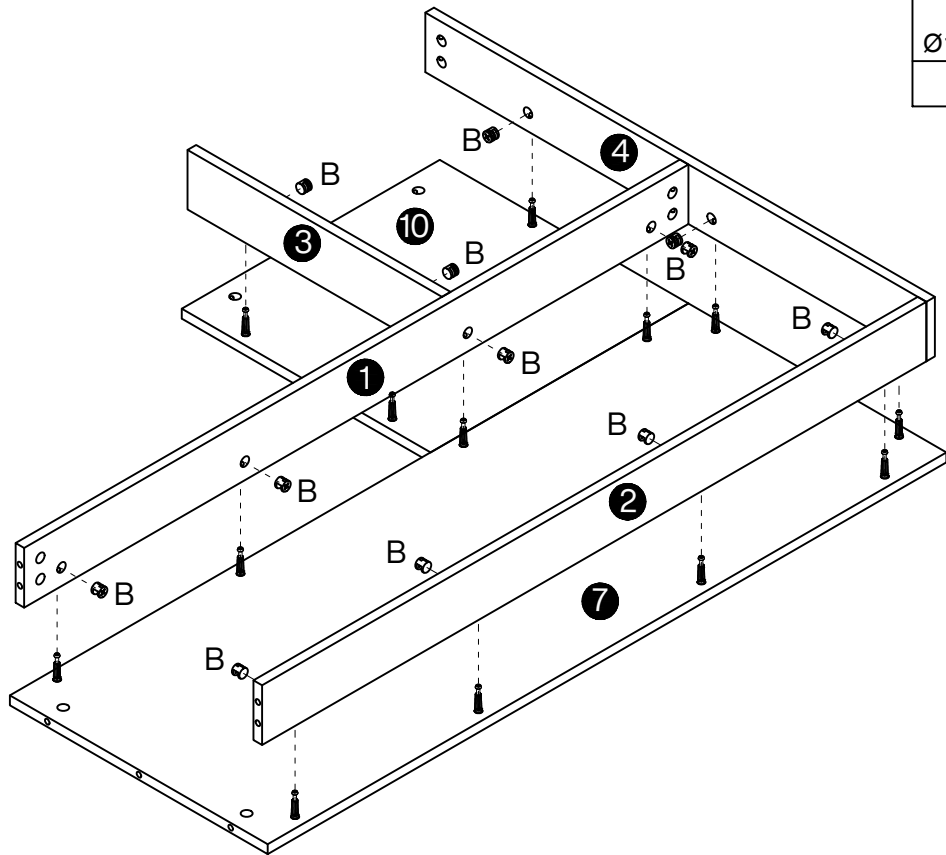

Step 3

6

D

M6x35mm
7 pcs

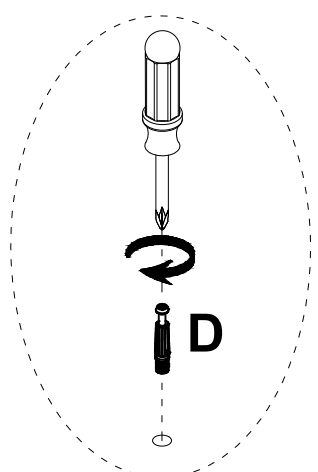
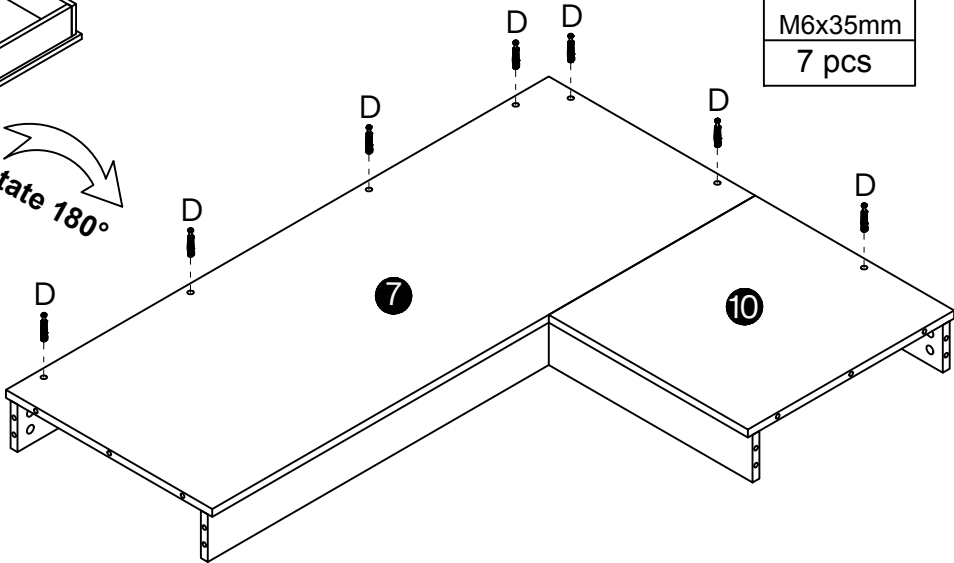
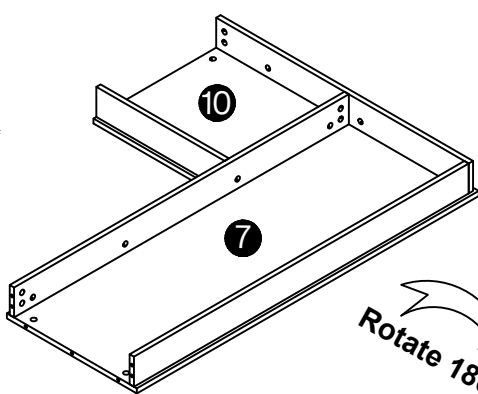

7

A

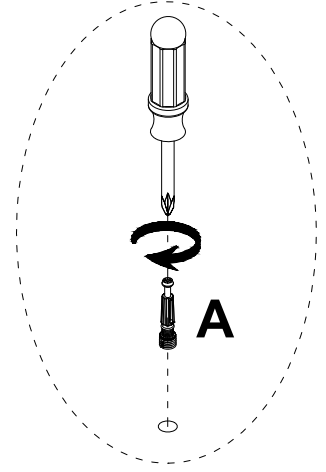
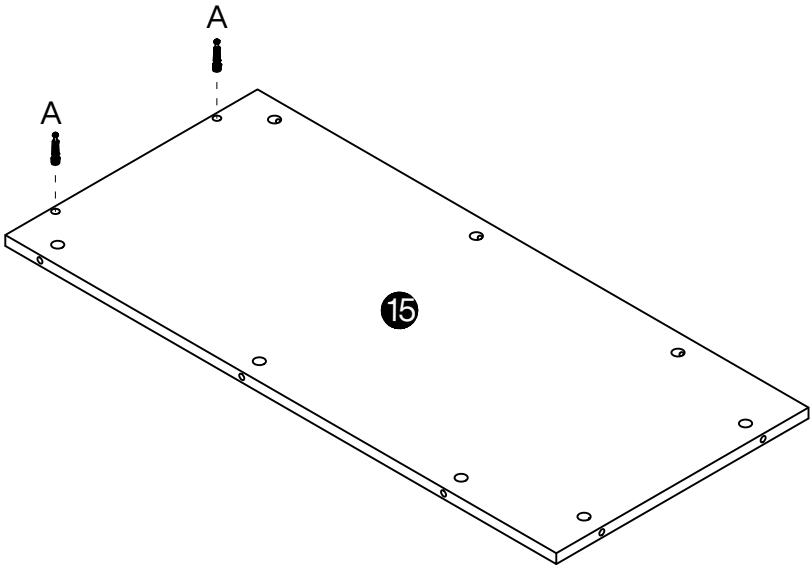
M6x35mm
2 pcs



8

B

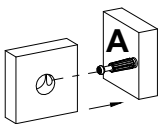
Ø15x12mm
2 pcs

Step 1

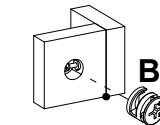

Step 2



Step 3

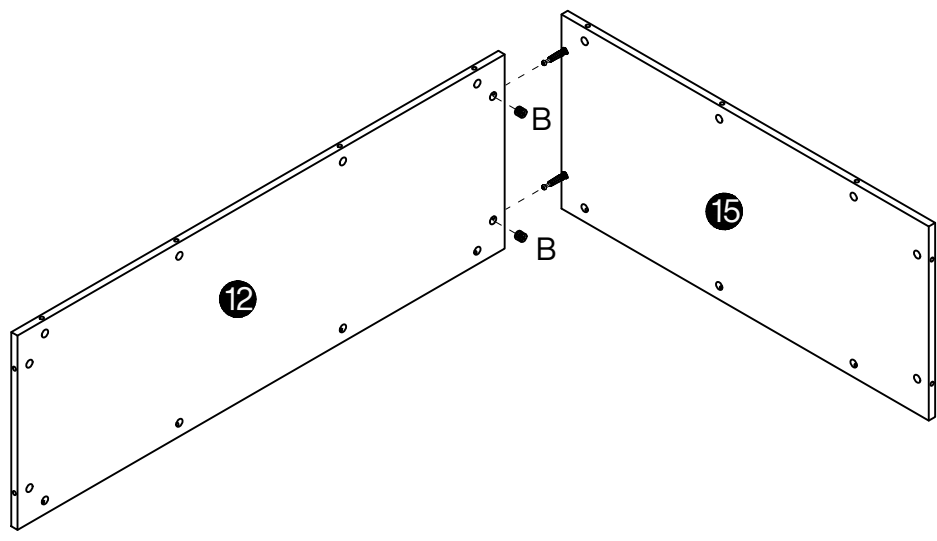
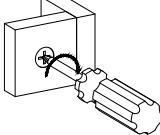

9

B

Ø15x12mm
7 pcs

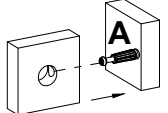
Step 1

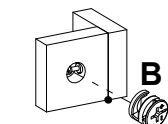

Step 2



Step 3

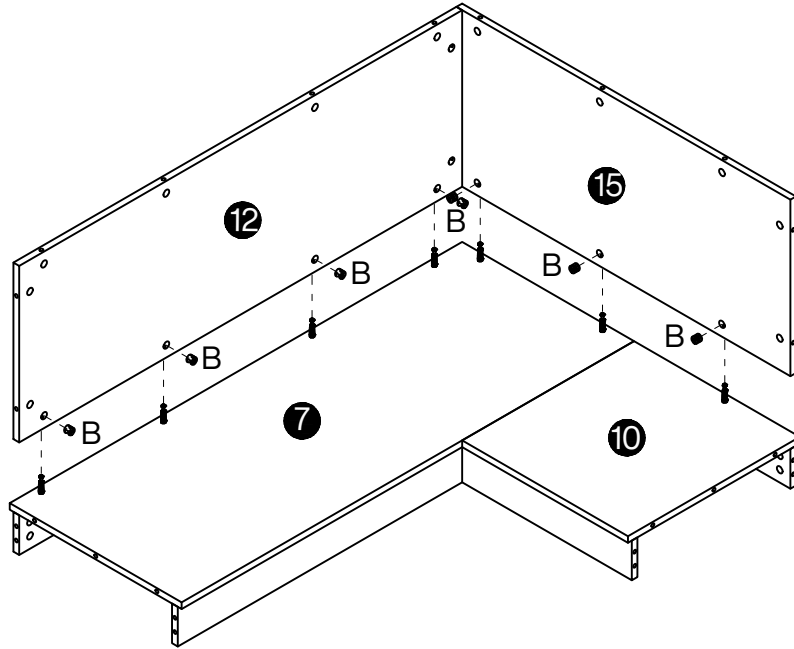
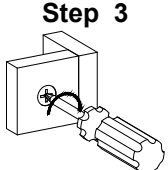

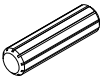

10

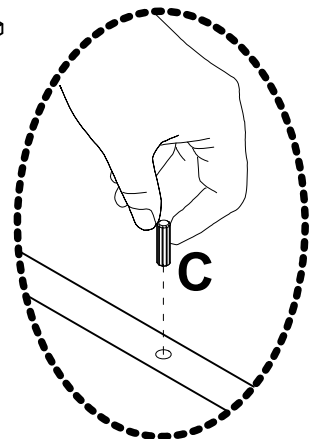
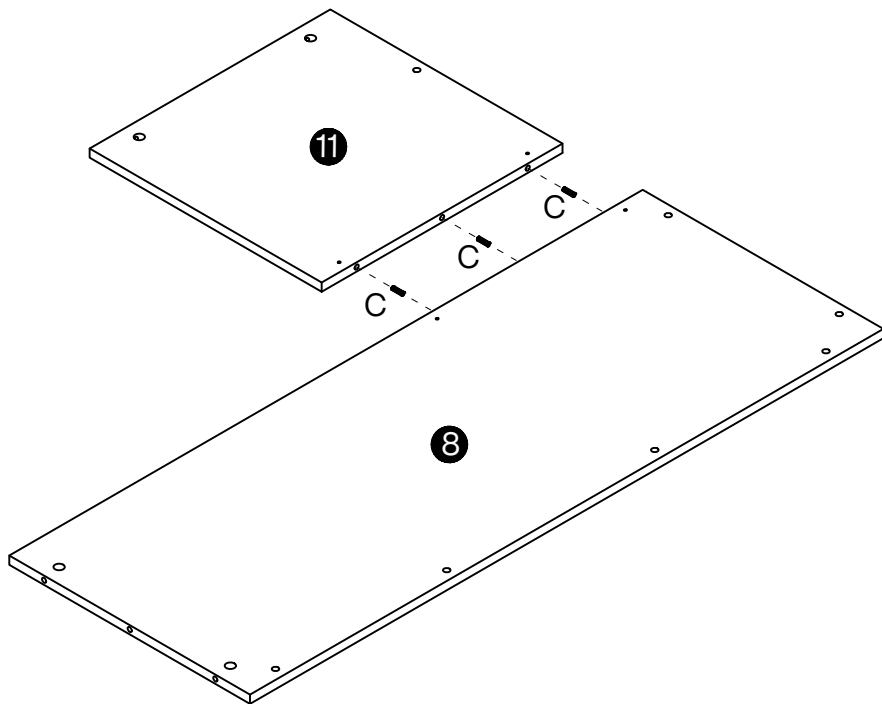
C

Ø8x30mm
3 pcs

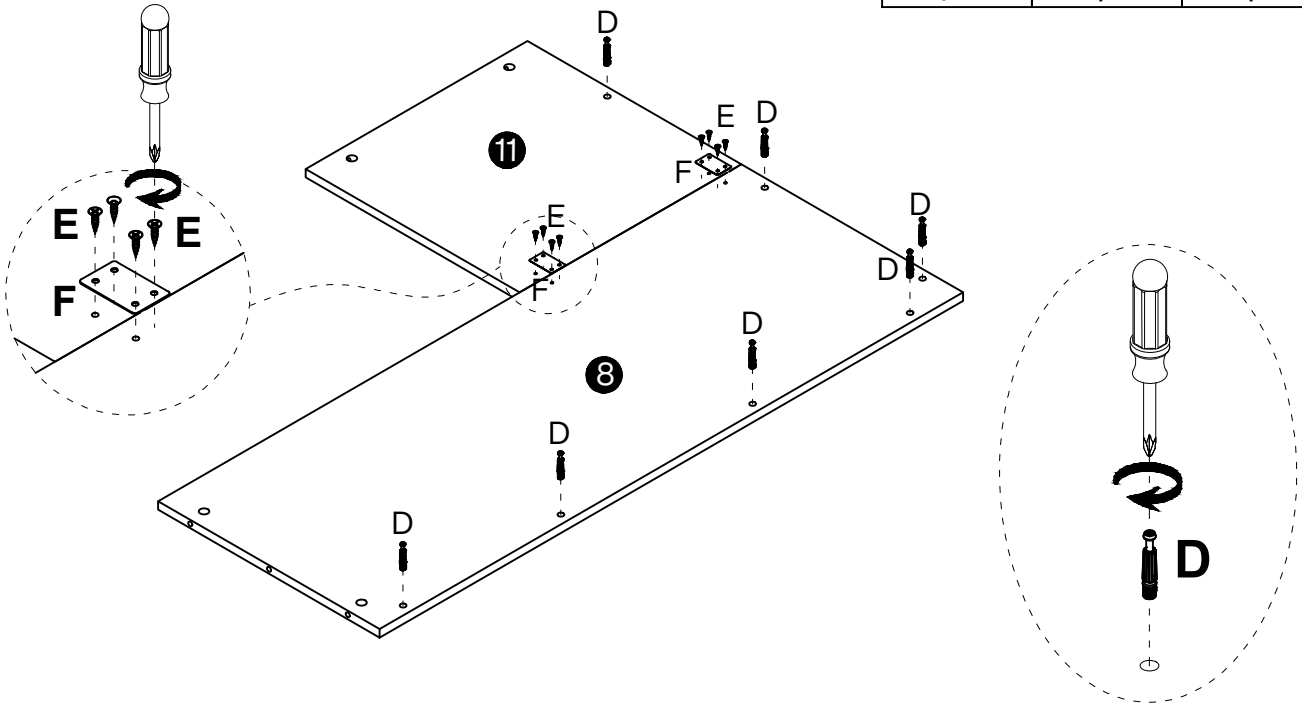

11

D	E	F
		
M6x35mm	Ø3.5x14mm	60x38mm
7 pcs	8 pcs	2 pcs



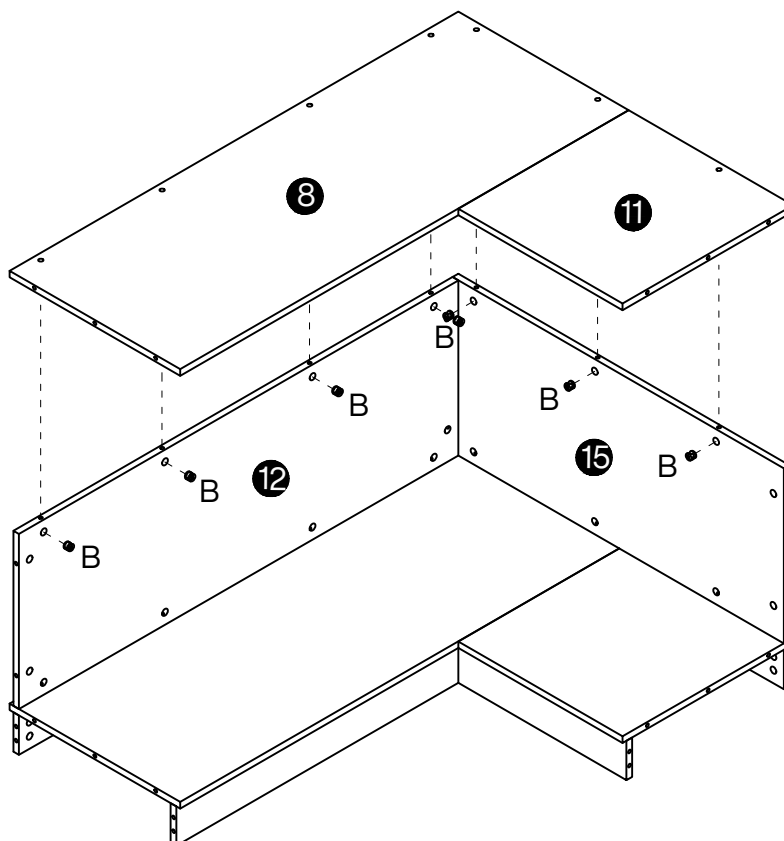
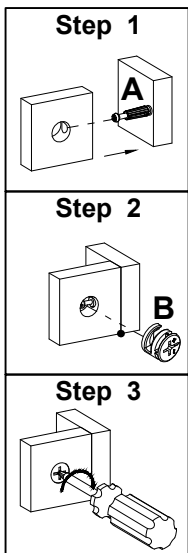

12

B

Ø15x12mm
7 pcs

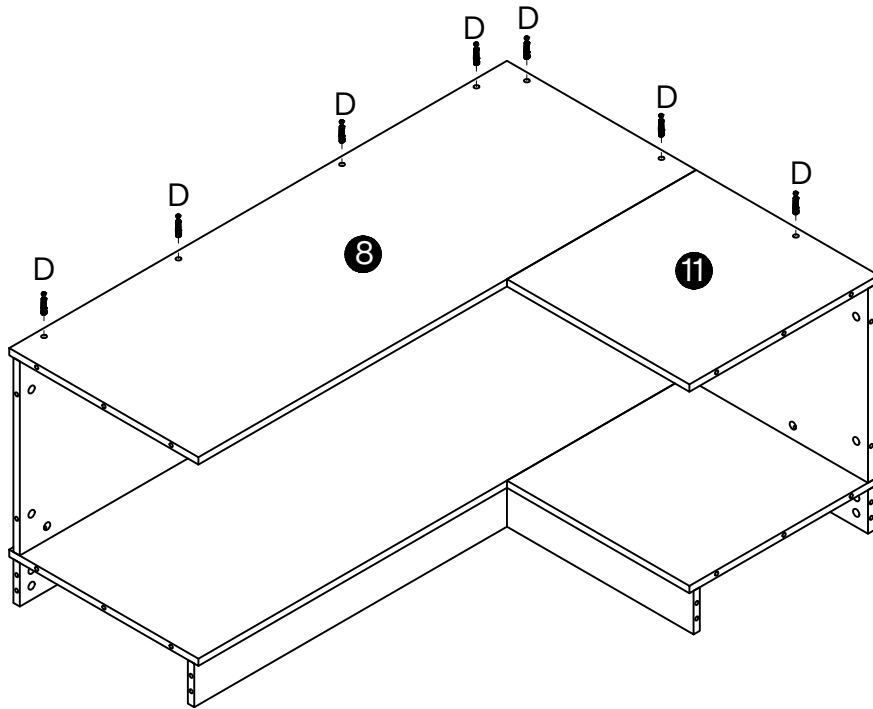

13

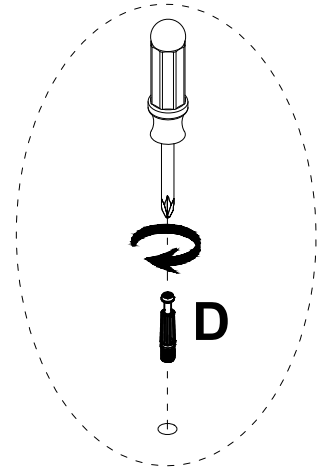

D

M6x35mm
7 pcs

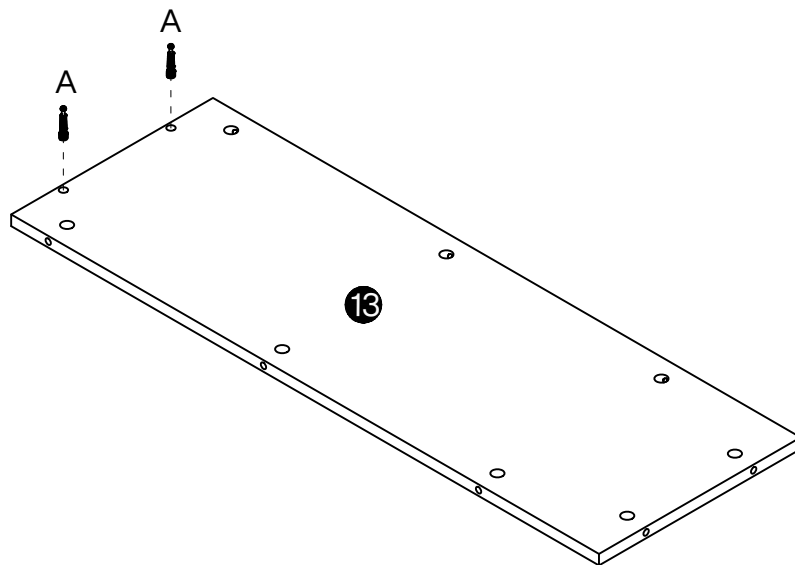

14

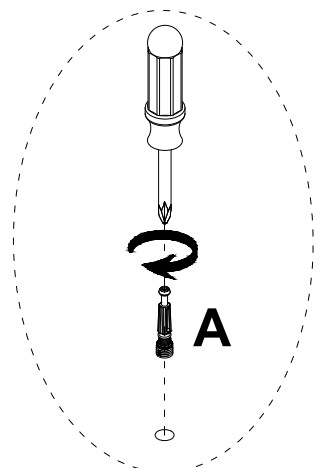

A

M6x35mm
2 pcs

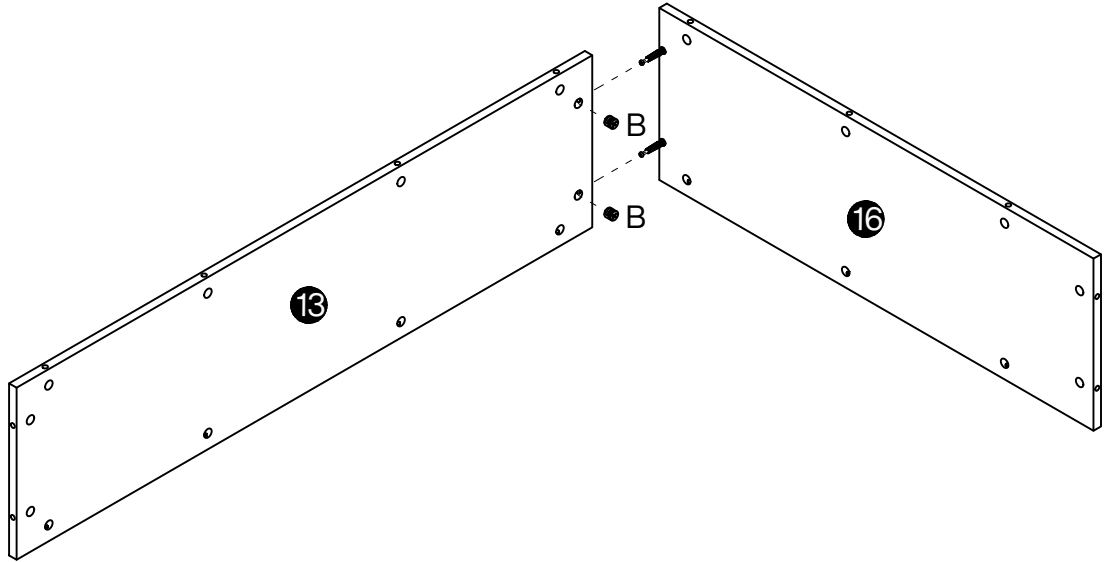
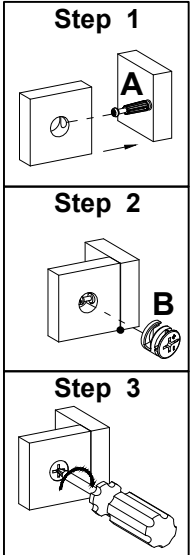

15

B

Ø15x12mm
2 pcs



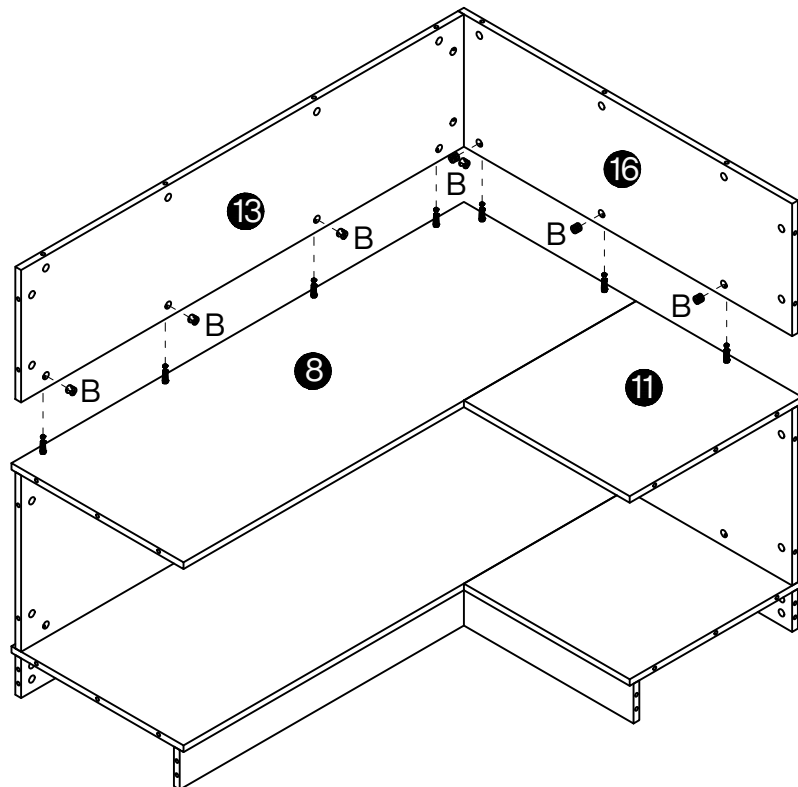
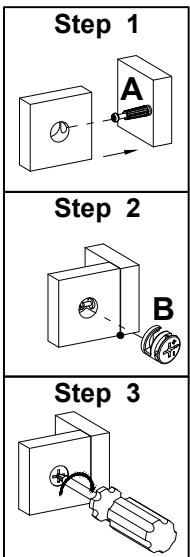

16

B

Ø15x12mm
7 pcs

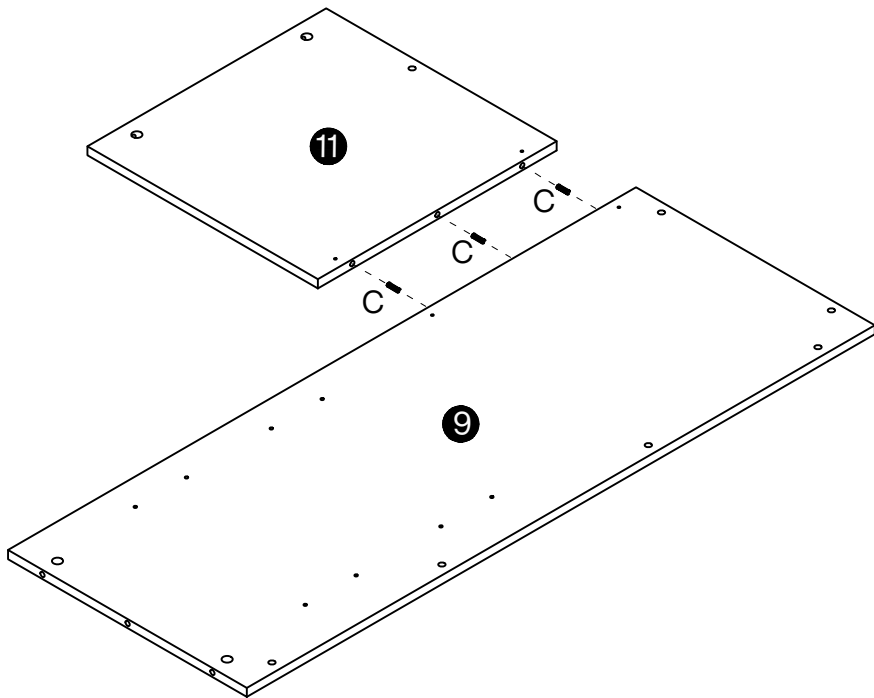

17



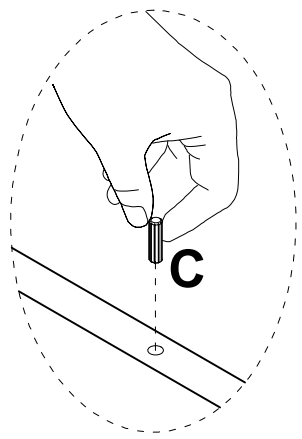

C

Ø8x30mm
3 pcs

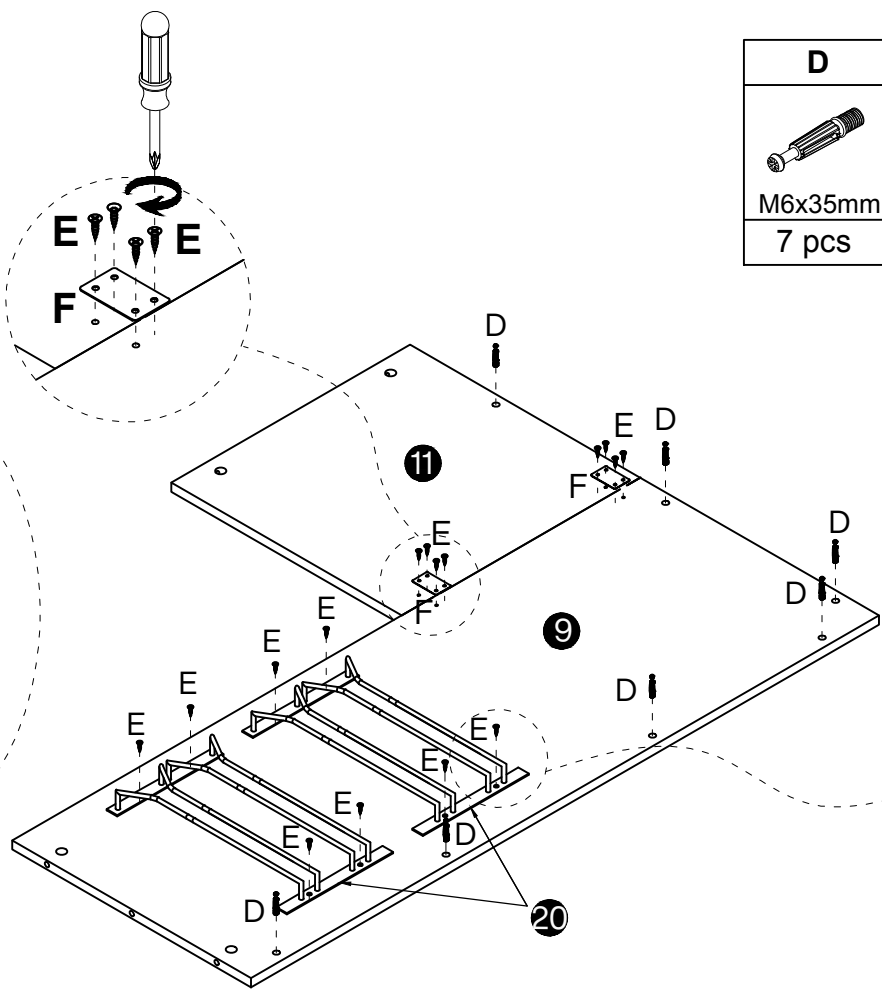

18

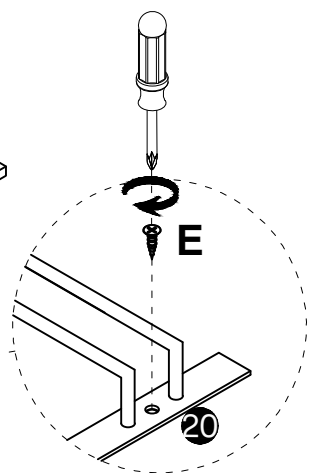
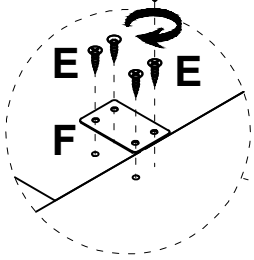
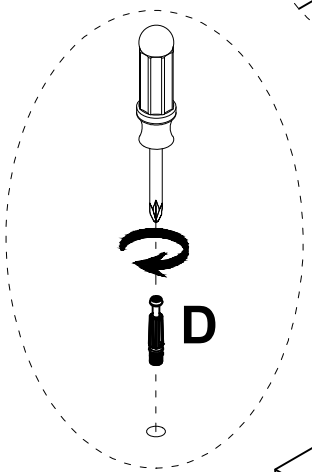

D	E	F
		
M6x35mm	Ø3.5x14mm	60x38mm
7 pcs	16 pcs	2 pcs



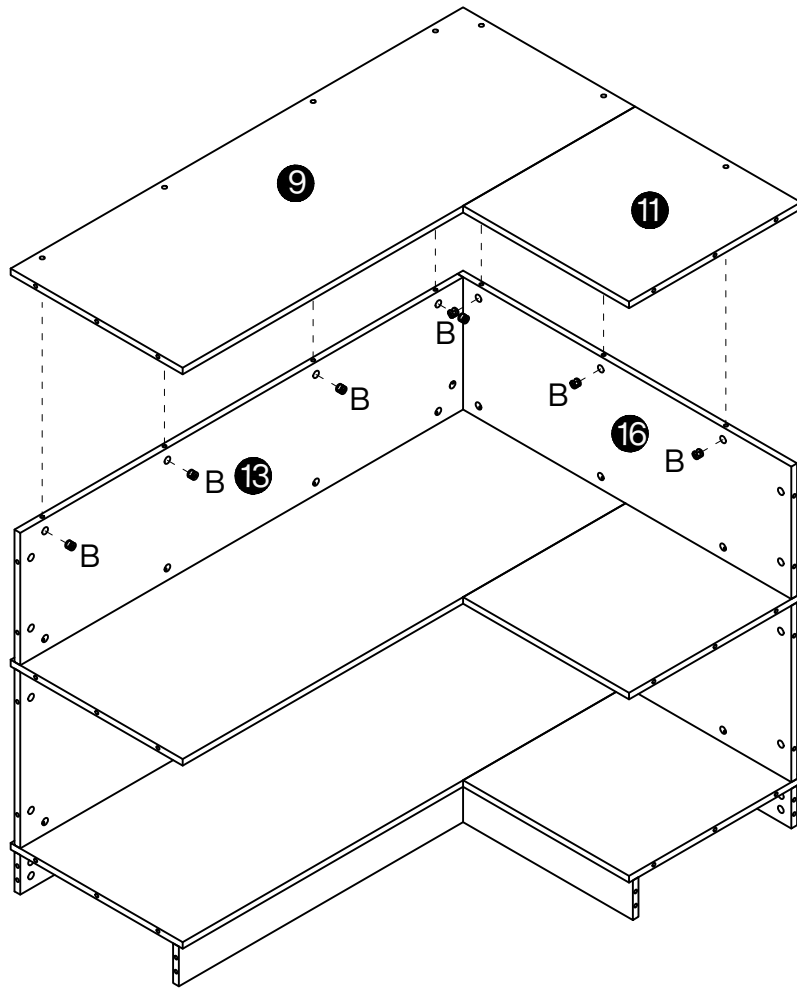
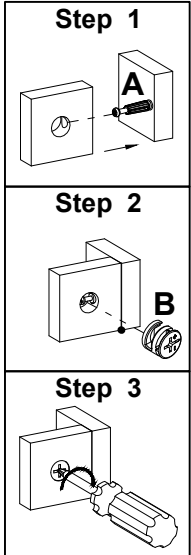

19

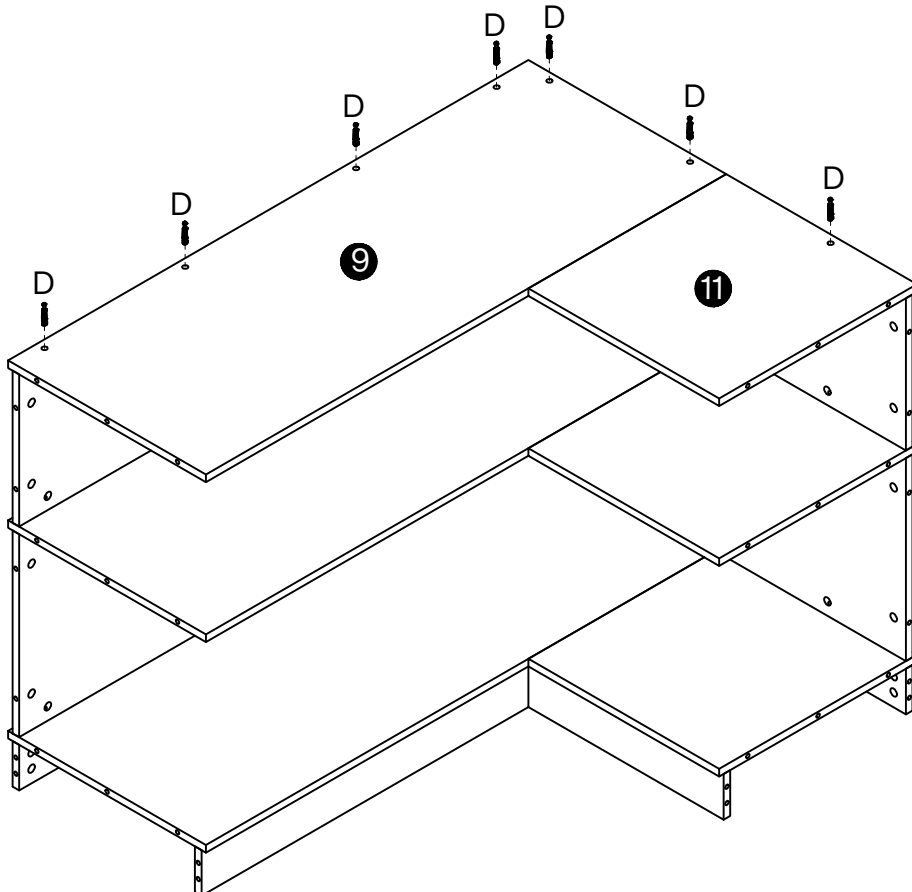

B

Ø15x12mm
7 pcs

20

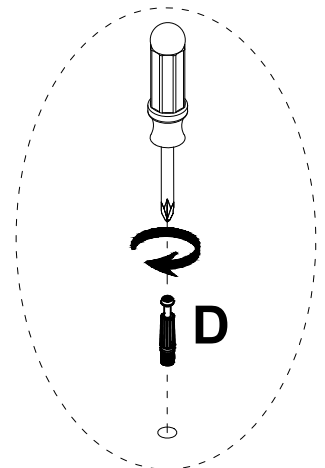

D

M6x35mm
7 pcs

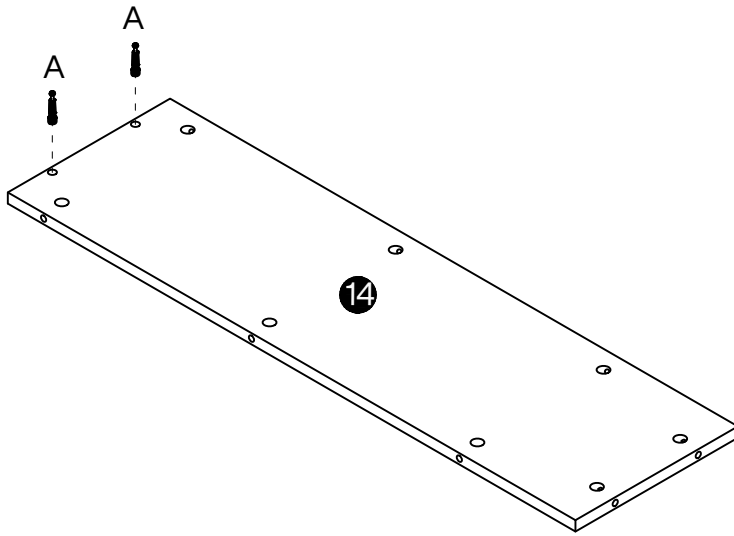

21

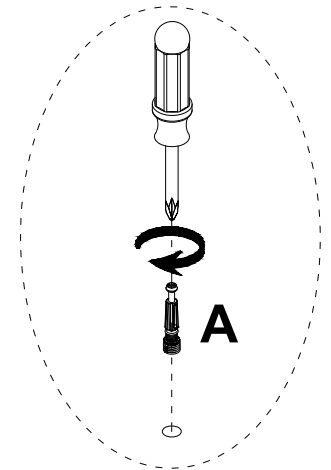

A

M6x35mm
2 pcs



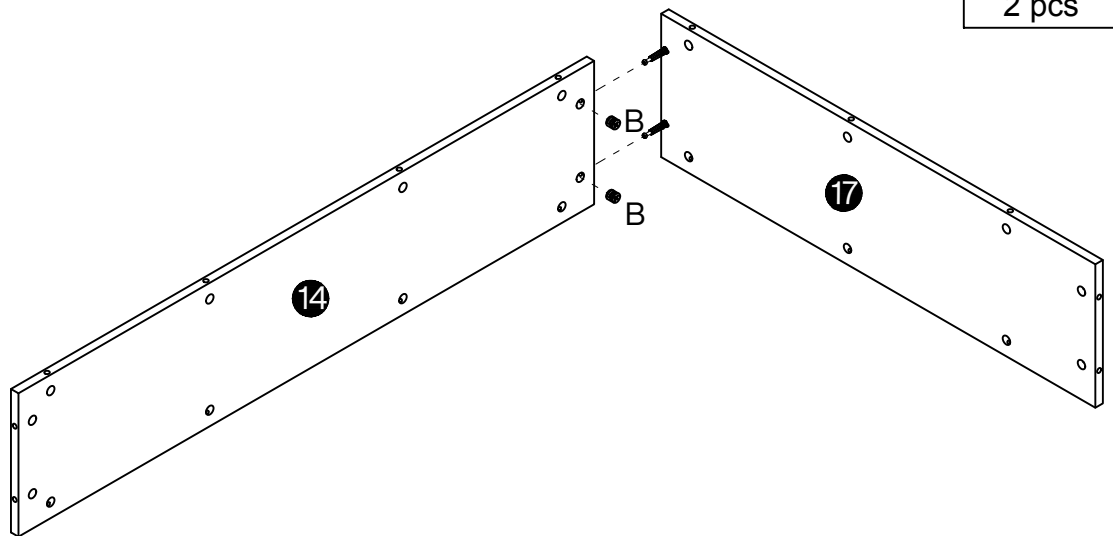
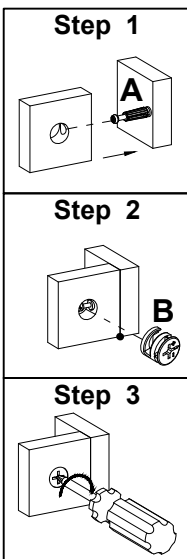

22

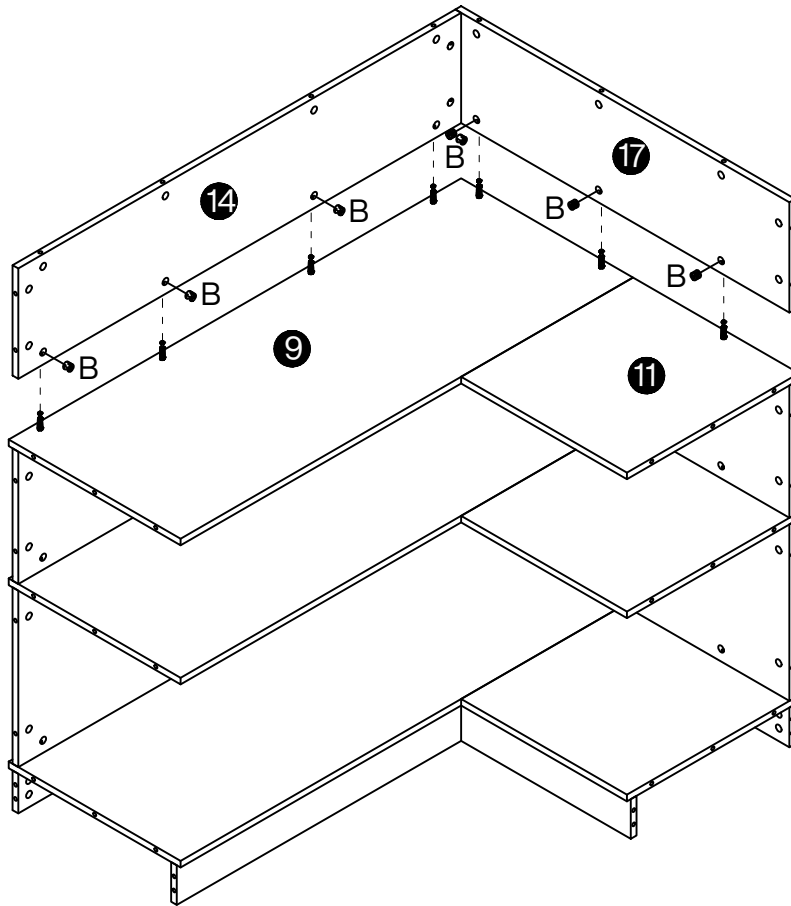
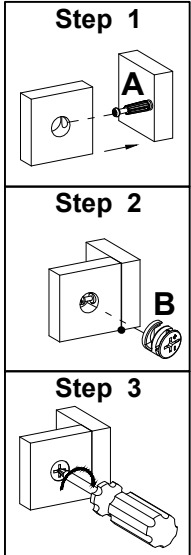

B

Ø15x12mm
2 pcs

23

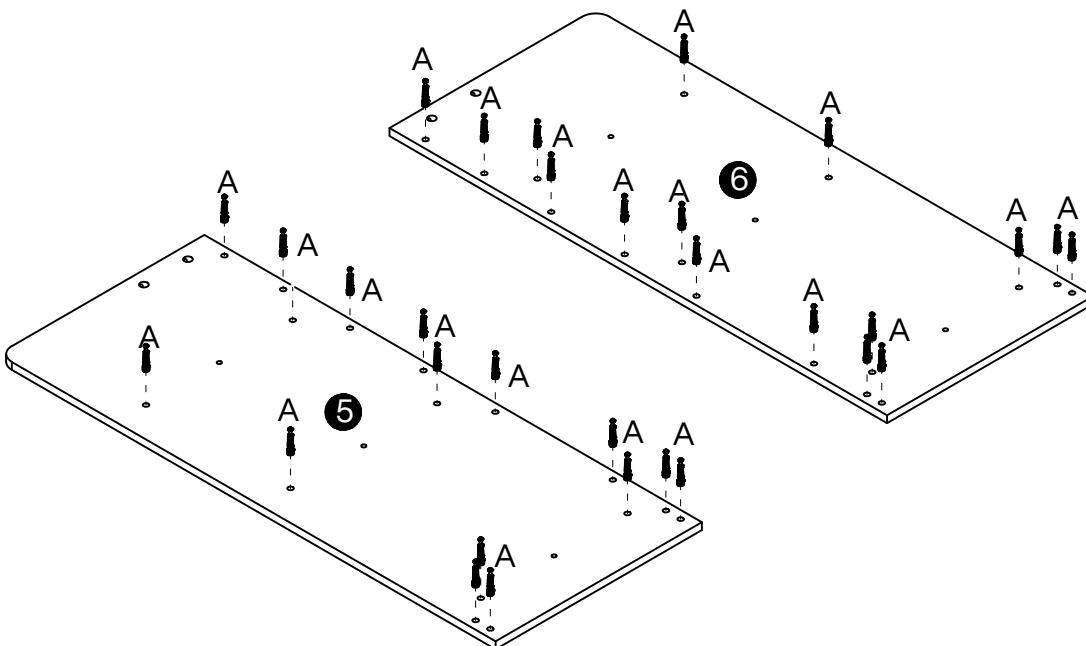

B

Ø15x12mm
7 pcs

24

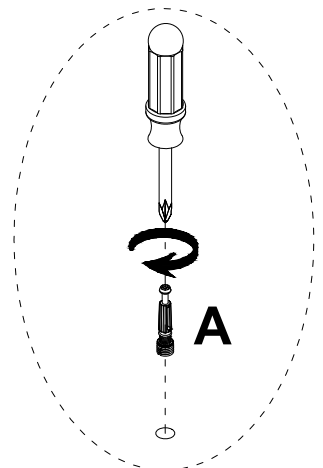

A

M6x35mm
32 pcs

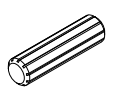

25

B	C
	
Ø15x12mm	Ø8x30mm
16 pcs	3 pcs

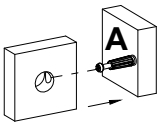
Step 1



Step 2

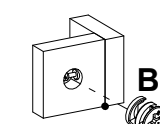

Step 3

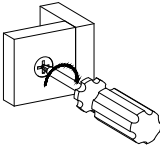
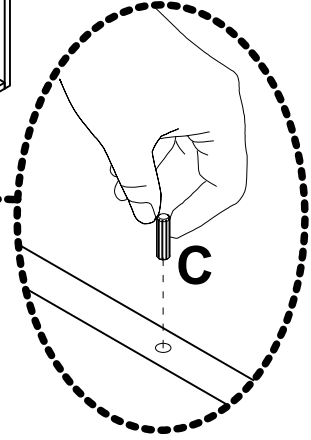
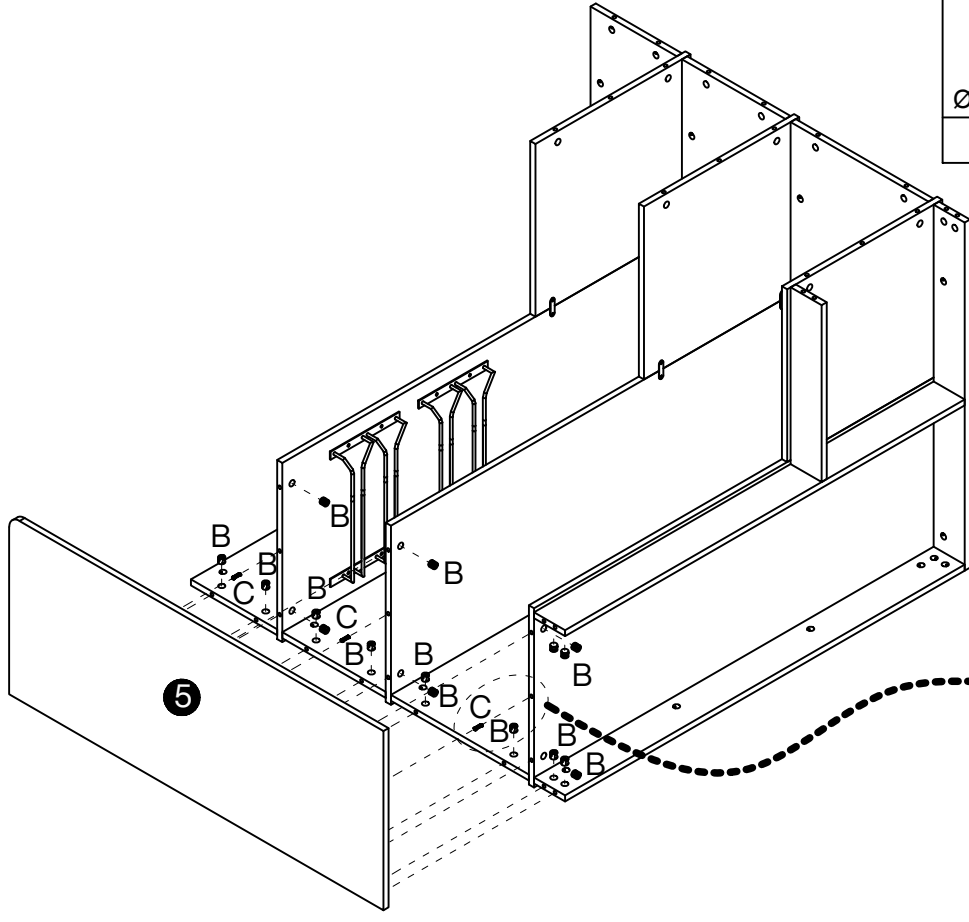
26

B	C
	
Ø15x12mm	Ø8x30mm
16 pcs	3 pcs

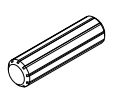
Step 1

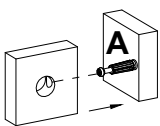

Step 2

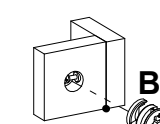

Step 3

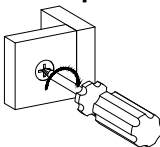
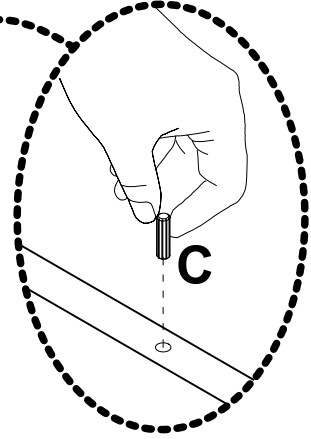
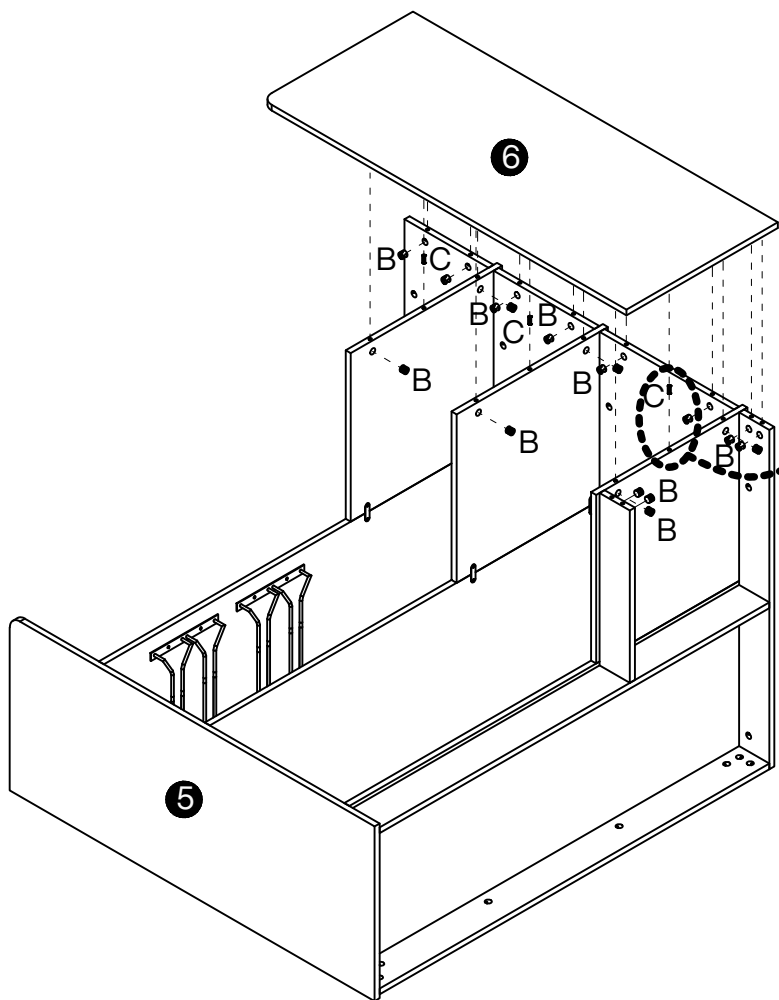

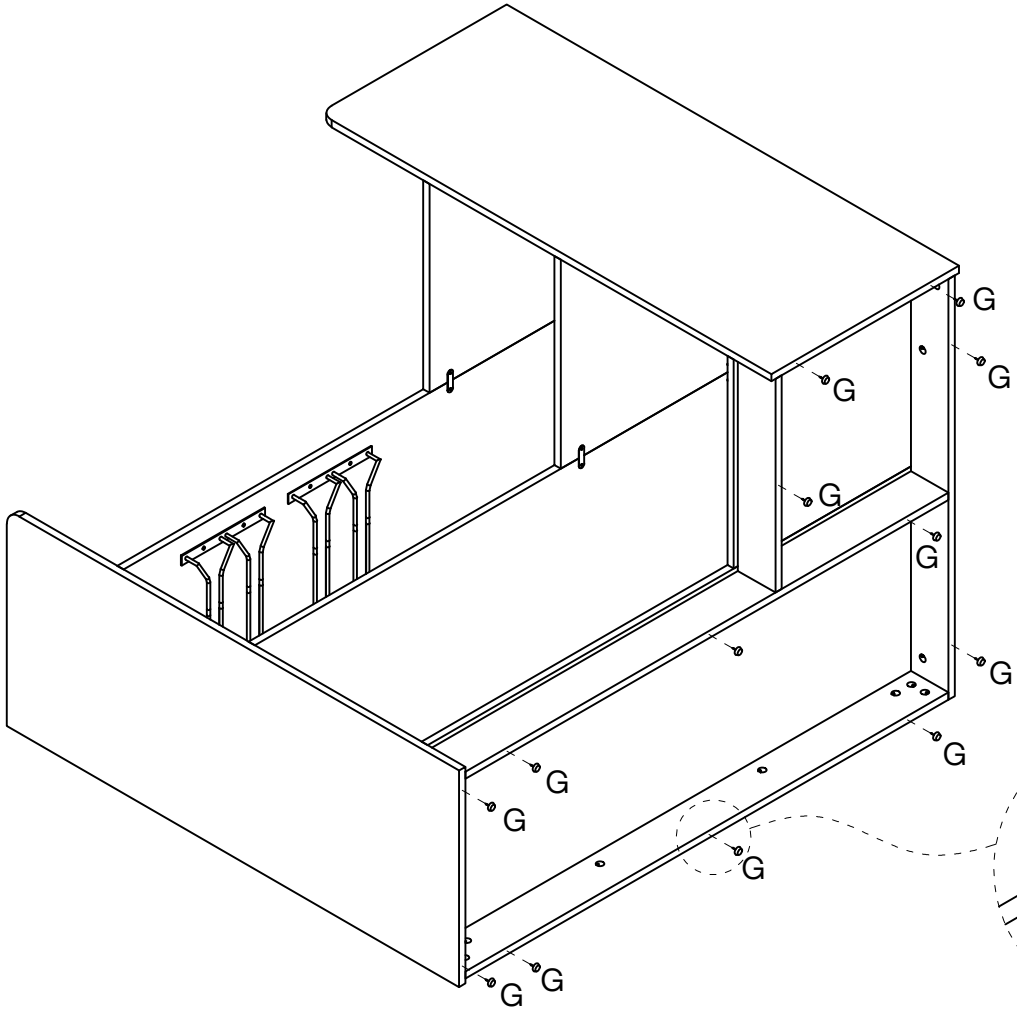

27



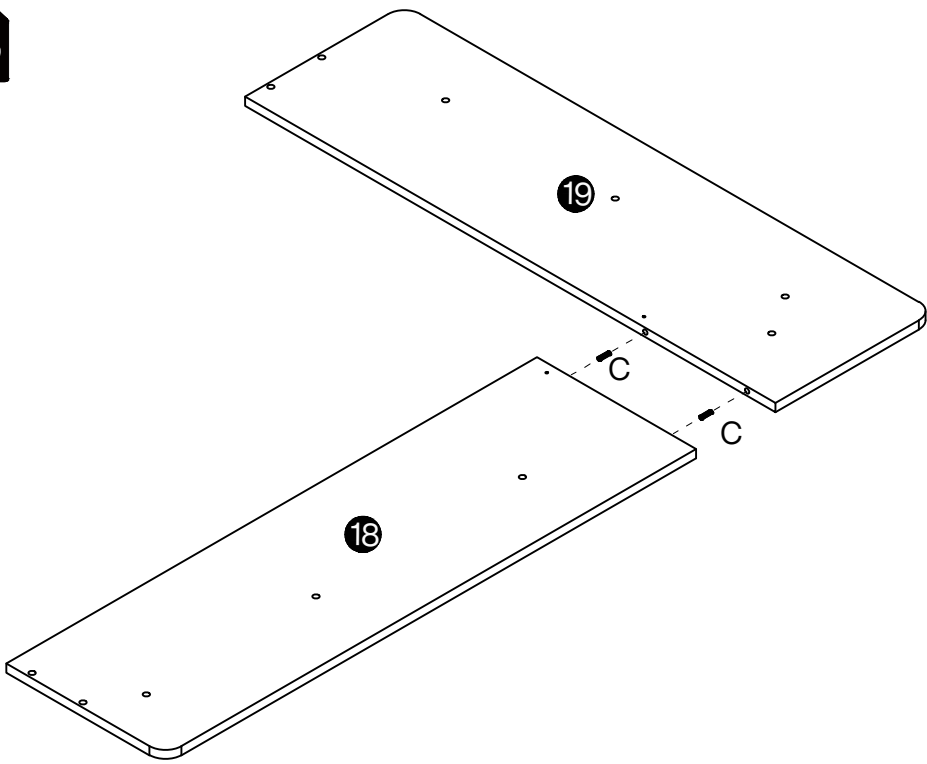

G

13 pcs

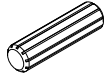
28

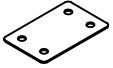

C

Ø8x30mm
2 pcs

29

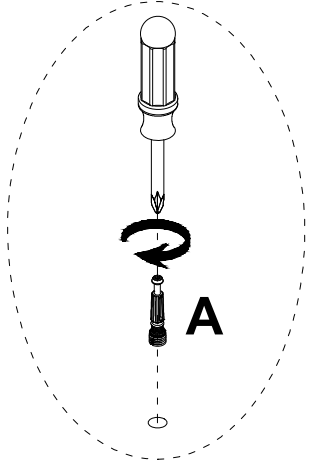
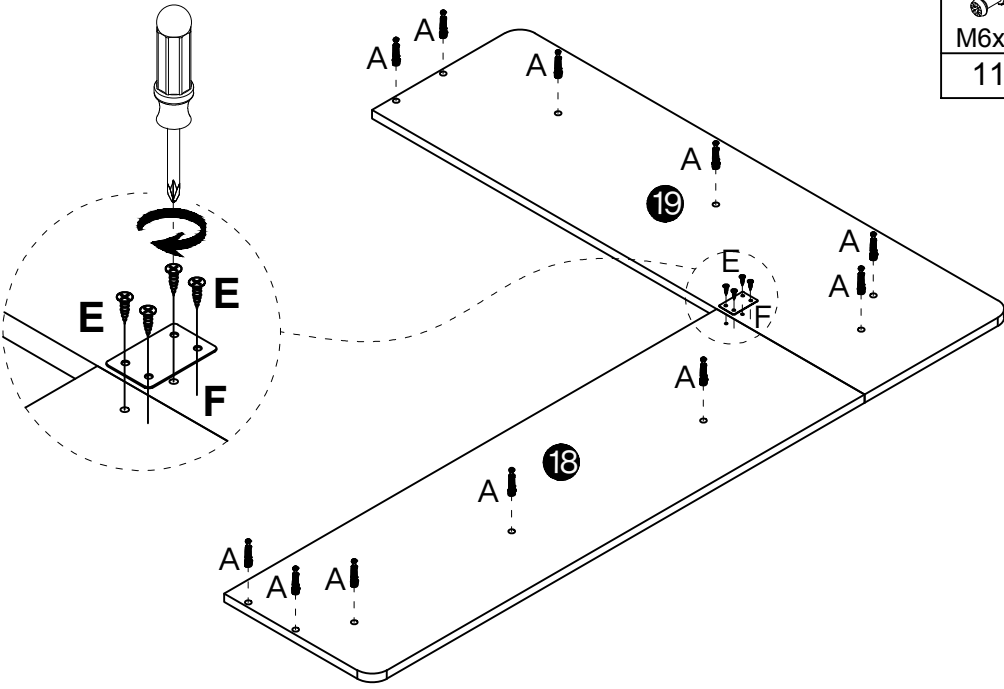
A	E	F
		
M6x35mm	Ø3.5x14mm	60x38mm
11 pcs	4 pcs	1 pc

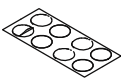

30

B	H
	
Ø15x12mm	Ø21
11 pcs	64 pcs

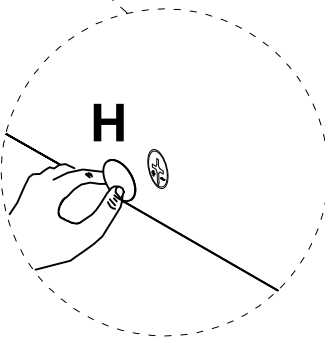
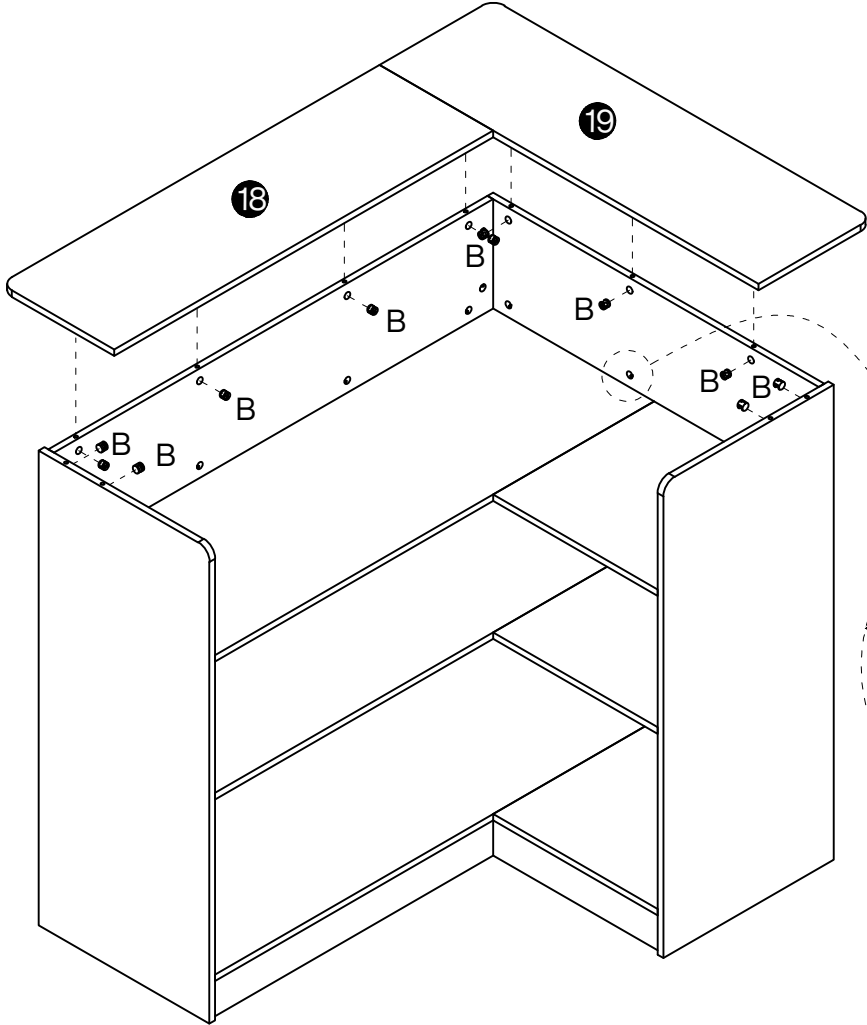
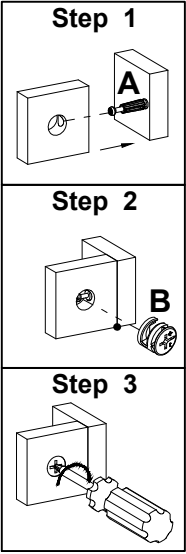

Thank you for your support !

