

A

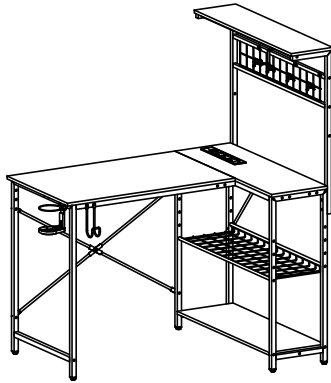

B

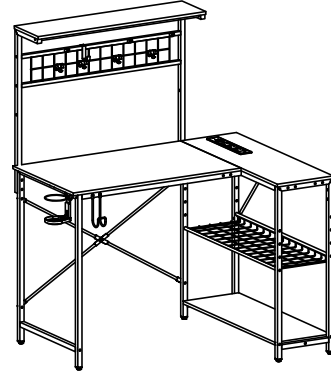

C

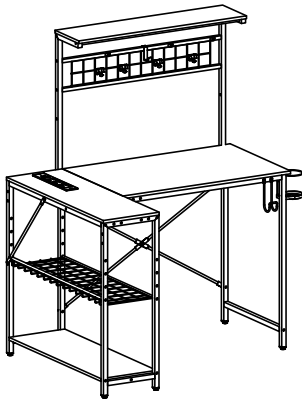

D

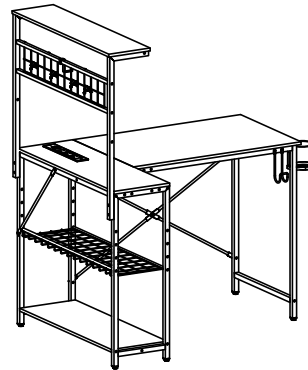

## ASSEMBLY INSTRUCTION

Montageanleitung

Instructions De Montage

Istruzioni Per L'assemblaggio

Instrucciones De Montaje

어셈블리 설명

組立説明書

安装说明书



## HELPFUL HINTS

### BEFORE YOU START

- Inspect product packaging to ensure the appearance is good.
- Read the assembly instruction carefully and follow it step by step.
- To avoid any scratching, putting a soft blanket on the floor is suggested.
- Identify, sort and count all the parts with tags.
- Find out installation position according to the drawing and install it in correct steps.

### OTHER

- People needed for assembly: 1-2.
- Estimated assembly time: 1-1.5h.

### CAUTION

- Be cautious when using a power drill or power screwdriver.
- Please be aware to slow down and stop when screw is nearly tight.
- Do Not use any harsh chemicals or abrasive cleaners for this item.
- Push, pull or drag this item carefully.

## ASTUCES UTILES

### AVANT DE COMMENCER

- Inspectez l'emballage du produit pour vous assurer que l'apparence est bonne.
- Lisez attentivement les instructions de montage et suivez-les étape par étape.
- Pour éviter toute rayure, posez une couverture douce sur le sol est suggéré.
- Identifiez, triez et comptez toutes les pièces avec des étiquettes.
- Trouver la position d'installation selon le dessin et l'installer dans les étapes correctes.

### AUTRE

- Personnes nécessaires pour l'assemblage : 1-2.
- Temps de montage estimé : 1-1.5h.

### AVERTIR

- Soyez prudent lorsque vous utilisez une perceuse électrique ou un tournevis électrique.
- Veuillez être conscient de ralentir et d'arrêter lorsque la vis est presque serrée.
- N'utilisez pas de produits chimiques corrosifs ou de nettoyants abrasifs pour cet article.
- Poussez, tirez ou tirez cet article avec précaution.

## CONSEJOS ÚTILES

### ANTES DE EMPEZAR

- Inspeccione el paquete del producto para asegurarse de que la apariencia es buena.
- Lea atentamente las instrucciones de montaje y sígalas paso a paso.
- Para evitar rayas, se sugiere poner una manta suave en el suelo.
- Identifique, clasifique y enumere todas las piezas con etiquetas.
- Averigüe la posición de instalación según el dibujo e instálela en los pasos correctos.

### OTROS

- Personas necesarias para el montaje: 1-2.
- Tiempo de montaje estimado: 1-1.5h.

### PRECAUCIÓN

- Tenga cuidado al utilizar un taladro eléctrico o un destornillador eléctrico.
- Tenga en cuenta que debe hacerlo más despacio y detenerse cuando el tornillo esté casi apretado.
- No utilice productos químicos agresivos ni limpiadores abrasivos para este artículo.
- Empuje, tire o arrastre este elemento con cuidado.

## SUGGERIMENTI UTILI

### PRIMA DI INIZIARE

- Controllare la confezione del prodotto per assicurarsi che sia in buono stato.
- Leggere con attenzione le istruzioni per l'assemblaggio e seguirle passo dopo passo.
- Per evitare graffi al pavimento, suggeriamo di stendervi una coperta morbida.
- Identificare, suddividere e contare tutte le parti con etichetta.
- Trovare la posizione adatta per il montaggio in base al disegno e montare lo scaffale seguendo correttamente i vari passaggi.

### ALTRO

- Persone necessarie per l'assemblaggio: 1-2.
- Tempo di assemblaggio stimato: 1-1.5ora.

### ATTENZIONE

- Prestare molta attenzione quando si utilizza un trapano elettrico o un cacciavite elettrico.
- Rallentare con accortezza e fermarsi quando una vite è già sufficientemente serrata.
- Non utilizzare prodotti chimici aggressivi o detergenti abrasivi su questo articolo.
- Spingere, tirare o trascinare questo articolo con cautela.

## NÜTZLICHE HINWEISE

### ⚠️ BEVOR SIE BEGINNEN

- Überprüfen Sie die Produktverpackung auf Schäden.
- Lesen Sie sich die Montageanleitung sorgfältig durch und befolgen Sie sie Schritt für Schritt.
- Um etwaiges Zerkratzen zu vermeiden, wird das Auslegen einer weichen Decke auf dem Boden empfohlen.
- Identifizieren, sortieren und zählen Sie alle Teile mit Tags nach.
- Identifizieren Sie die Montageposition gemäß der Zeichnung und bauen Sie das Regal den richtigen Schritten entsprechend auf.

**SONSTIGES**

- Für den Zusammenbau erforderliche Anzahl an Menschen: 1-2.
- Ungefähre Montagedauer: 1-1.5h.

### ⚠️ VORSICHT

- Seien Sie bei der Verwendung einer Bohrmaschine oder eines Akkuschraubers vorsichtig.
- Bitte vergessen Sie nicht darauf, langsamer zu werden und zu stoppen, sobald die Schraube fast festgezogen ist.
- Verwenden Sie keinerlei aggressive Chemikalien oder scheuernden Reinigungsmittel für dieses Produkt.
- Schieben oder ziehen Sie dieses Produkt vorsichtig.

## 유용한 힌트

### ⚠️ 시작하기 전에

- 제품 포장 검사, 확보외관이 좋다.
- 어셈블리 지침 자세히 보기한 걸음 한 걸음 그것을 따르다
- 굽히지 않도록 바닥에 부드러운 담요를 놓는 것이 좋습니다
- 모든 부품을 라벨로 식별, 분류 및 계산합니다.
- 도면에 따라 설치 위치를 찾아 올바른 단계에 따라 설치합니다.

**기타**

- 조립에 필요한 인원: 1-2명.
- 예상 조립 시간: 1-1.5h.

### ⚠️ 안전에 주의하다:

- 전기 드릴이나 전기 드라이버를 사용할 때는 조심해야 한다
- 나사가 거의 조이면 속도를 줄이고 멈추십시오
- 자극성 화학물질이나 연마성 세정제는 이 품목에 사용하지 마십시오.
- 이 항목을 조심스럽게 밀거나 당기거나 드래그합니다

## 役に立つヒント

### ⚠️ 組立の場所を確保し、順番通りに組み立てる

- 組立場所 (充分広くて平たい場 所) を確保してください。
- 床や壁、商品を傷つけないように、商品の下に厚めの布や段ボールなどを敷いてください。
- 組立の順番を守らないと、組立できなくなったり、商品を傷つけたりします。

**その他**

- 組み立てに必要な人:1-2.
- 組立時間: 約1-1.5時間.

### ⚠️ 部品を確認する

- ネジ類などの部品番号、形状を説明書の部品一覧で確認してください。
- 部品をなくさないように纏めて置いてください。
- 部品を取り出すときに使う分だけ取り出してください。

## 温馨提示

### ⚠️ 安装前注意事项

- 检查产品包装，确保外观良好。
- 仔细阅读安装说明，按步骤操作。
- 为了避免刮伤，建议在地板上放一条柔软的毯子。
- 标识、分类和清点所有部件。
- 根据图形找到安装孔位，按正确步骤安装。

**其他:**

- 组装所需人员:1-2人.
- 预计组装时间: 1-1.5小时.

### ⚠️ 注意:

- 小心使用电钻或电动螺丝刀。
- 当螺丝快要拧紧时，请注意减速。
- 不要使用任何刺激性化学物质或擦洗剂。
- 当推、拉或拖动产品时，注意小心谨慎，防止损坏。

# DETAILS

DÉTAILS/POINTS DE MONTAGE  
NOTE PARTICOLARI  
DETALLES

디테일  
組み立てのポイント  
詳細情報

UNIT:INCH/CM/厘米

A

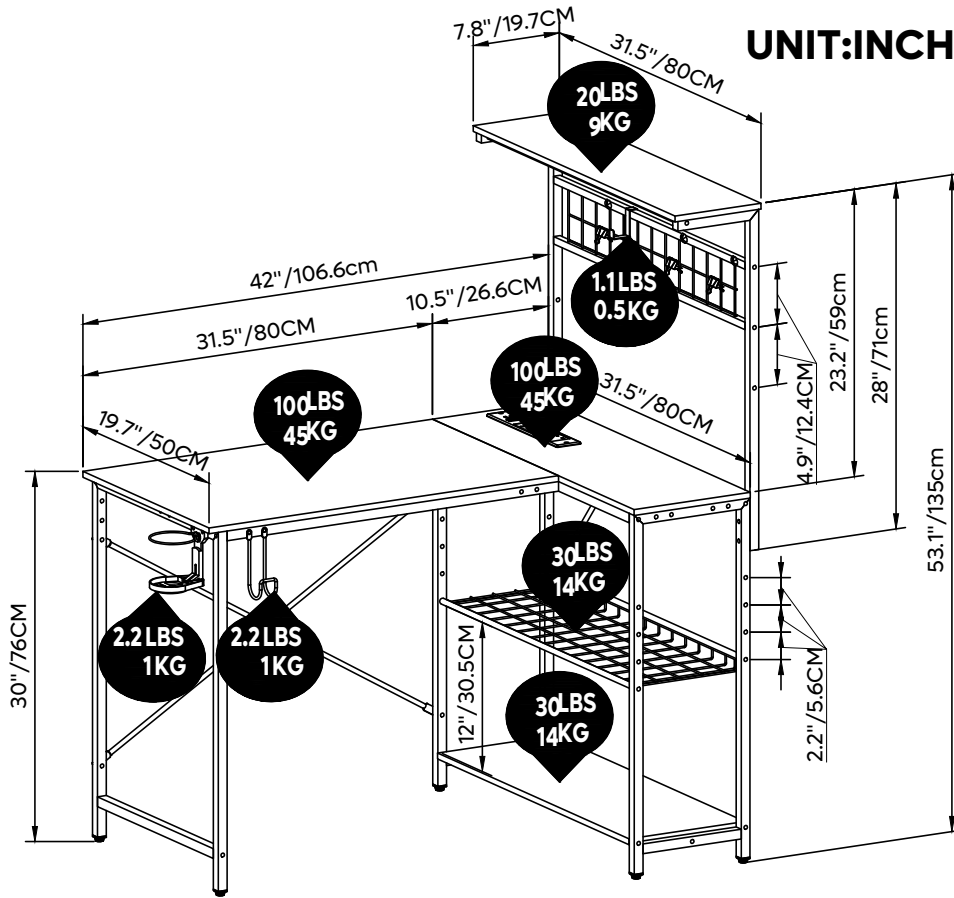

C

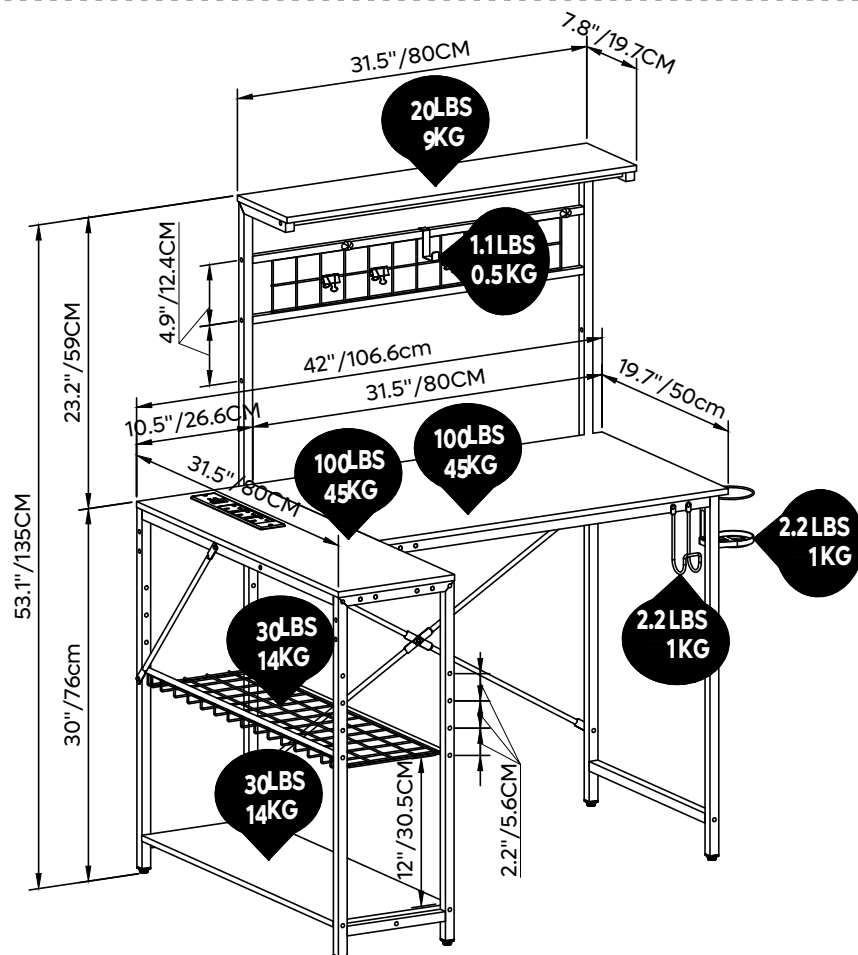

# DETAILS

DÉTAILS/POINTS DE MONTAGE  
NOTE PARTICOLARI  
DETALLES

디테일  
組み立てのポイント  
詳細情報

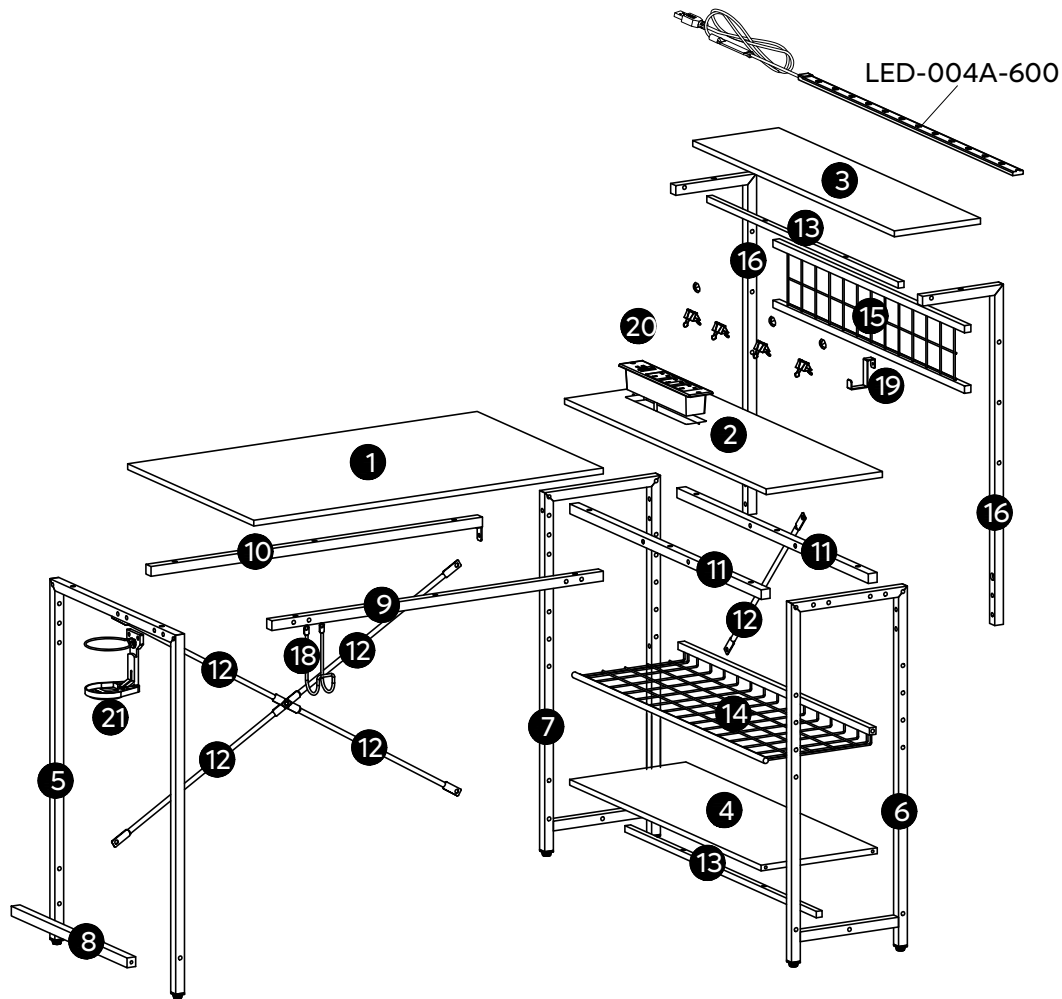

## PART LIST

STÜCKLISTE  
LISTE DES PIÈCES  
ELENCO DEI PEZZI

LISTA DE PIEZAS  
부품 목록  
部品の確認/部件清單

1

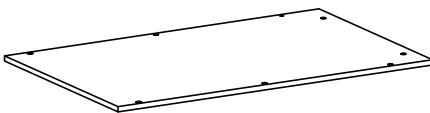

X1

2

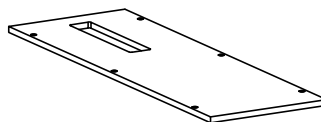

X1

3

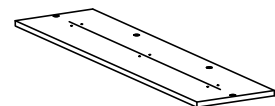

X1

4

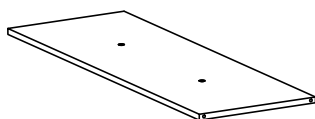

X1

5

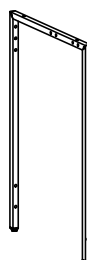

X1

6

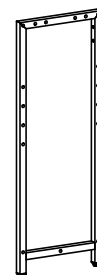







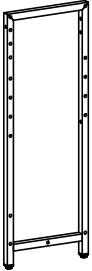
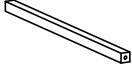

X1

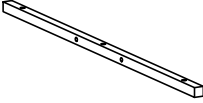
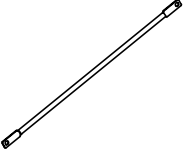
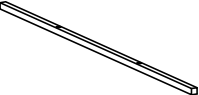
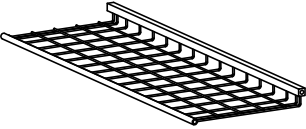
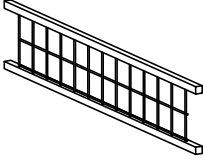
# PART LIST

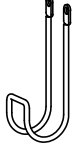
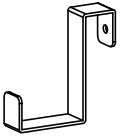
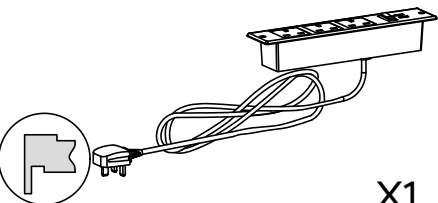
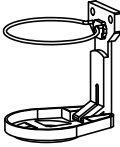
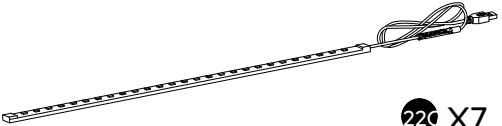
STÜCKLISTE  
LISTE DES PIÈCES  
ELENCO DEI PEZZI









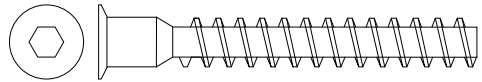
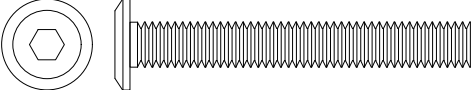
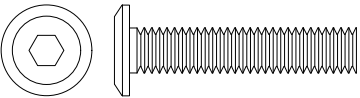
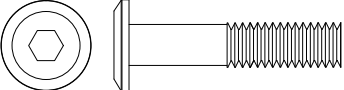
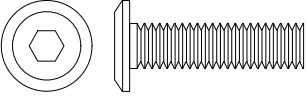
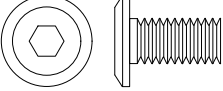

LISTA DE PIEZAS  
부품 목록  
部品の確認/部件清單

<p>7</p>  <p>X1</p>	<p>8</p>  <p>X1</p>	<p>9</p>  <p>X1</p>
<p>10</p>  <p>X1</p>	<p>11</p>  <p>X2</p>	<p>12</p>  <p>X5</p>
<p>13</p>  <p>X2</p>	<p>14</p>  <p>X1</p>	<p>15</p>  <p>X1</p>
<p>16</p>  <p>X2</p>	<p>17 (included in hardware package)</p>  <p>M4</p> <p>X1</p>	<p>18</p>  <p>X1</p>
<p>19</p>  <p>X1</p>	<p>20</p> <p>E-3A2U1S</p>  <p>X1</p>	<p>21</p>  <p>X1</p>
<p>22 LED-004A-600</p>  <p>22A X1</p> <p>22C X7</p>  <p>ST3.5x10mm</p> <p>22E X3</p>   <p>X1</p>		

# ACCESSORY LIST

ZUBEHÖRLISTE  
LISTE DES ACCESSOIRES  
ELENCO DEGLI ACCESSORI

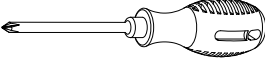
LISTA DE ACCESORIOS  
부품 목록  
付屬品部品の確認/配件清單

<b>A</b>	ST7x50mm	4+1	
<b>B</b>	M6x45mm	4+1	
<b>C</b>	M6x30mm	4+1	
<b>D</b>	M6x28mm	4+1+2	
<b>E</b>	M6x23mm	4+1	
<b>F</b>	M6x12mm	1	
<b>G</b>		3	
<b>H</b>	ST4x14mm	2	
<b>I</b>	M6	16+1	
<b>J</b>		4	
<b>W</b>		2	 <b>W1</b> x1  <b>W2</b> x1  <b>W3</b> x2  <b>W4</b> x1 ST4x38mm
		1	
		1	
	M4	1	

# Detailed Installation for LED Strip

Installation détaillée de la bande LED  
 Ausführliche Anbringungsanleitung für LED-Streifen  
 Installazione dettagliata della striscia LED  
 Instalación detallada de la tira de LED  
 LED 막대 상세 설치  
 LED 스트립 라이트의設置に関する詳細説明  
 LED 灯带安装方法

**1** Remove about 25mm (1") of adhesive tape at both ends of LED light strip.

Retirez environ 25 mm de ruban adhésif à chaque extrémité de la bande lumineuse LED.

An beiden Enden des LED-Streifens etwa 25 mm (1 Zoll) des Klebebandes entfernen.

Rimuovere circa 25 mm di nastro adesivo su entrambe le estremità della striscia luminosa a LED.

Retire unos 25 mm (1") de la cinta adhesiva en ambos extremos de la tira de luces LED.

LED 램프의 양쪽 끝에서 약 25mm(1인치)의 테이프를 제거합니다.

LED 스트립 라이트의 兩端にある粘着テープを約25mm (1") はがしてください。

揭开LED灯带两端的胶纸约25mm (1")。

**1**

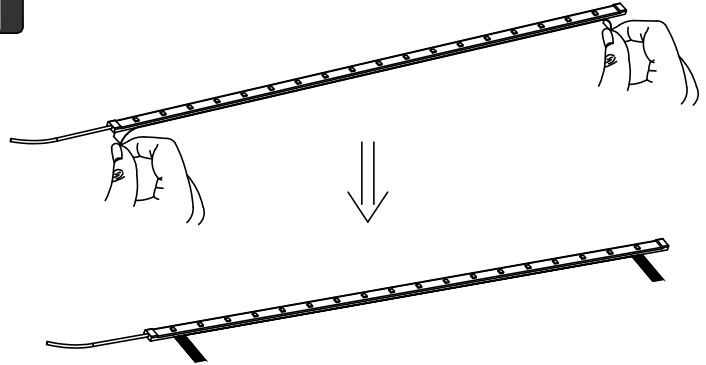

**2** The head and tail of the LED light strip are pasted in a straight line, and the fixing parts at both ends are locked with screws.

Tête et queue du ruban LED collé sur une ligne droite, et les pièces de fixation situées à chaque extrémité sont sécurisées par des vis.

Kopf und Heck des LED-Lichtstreifens sind in einer geraden Linie geklebt und die Befestigungselemente anschrauben.

La testa e la coda della striscia luminosa LED sono incollati in un dritto Linea, e le parti di fissaggio ad entrambe le estremità sono bloccate con viti.

La cabeza y la cola del cinturón de Luz LED se pegan en línea recta Cable, las piezas de fijación en ambos extremos están cerradas con tornillos.

램프의 머리과 꼬리는 일직선으로 붙여져 있고 양쪽 끝의 고정 부품은 나사로 단단히 잠겨 있습니다.

LED 라이트 밴드의 頭部と尾部を直線に貼り付けるワイヤ、兩端の固定具はネジでロックします。

LED灯带头尾沿着直线粘贴,用螺丝将两端的固定件锁住。

**2**

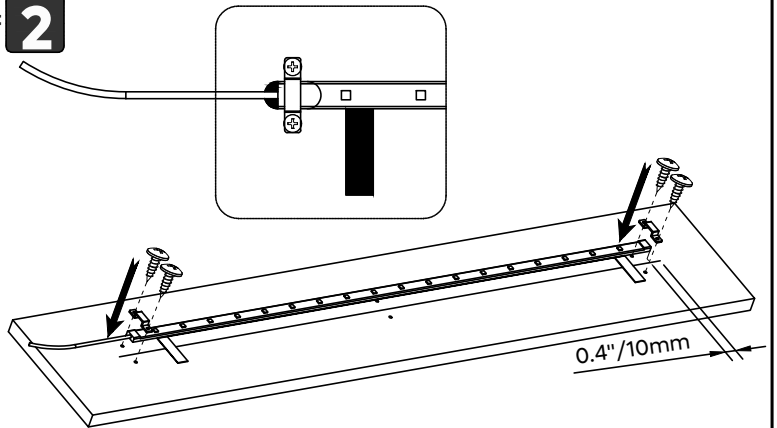

**3** Tear off the whole protective paper, and flatten the strip light so that the LED light strip is completely adhered to the wood.

Arrachez tout le papier de protection et aplatissez la bande lumineuse de manière à ce que la bande lumineuse à DEL soit complètement collée au bois.

Die gesamte Schutzfolie abziehen und den LED-Streifen so flach andrücken, dass er vollständig auf dem Holz aufliegt.

Strappare l'intera carta protettiva e appiattire la striscia luminosa in modo da farla aderire completamente al legno.

Retire todo el papel protector y aplane la tira de luz para que la tira de luz LED quede completamente adherida a la madera.

보호지 전체를 찢고 막대 램프를 눌러 LED 램프가 나무에 완전히 달라붙도록 합니다.

全体の保護ペーパーをはがしてLED 스트립 라이트を平らにして、木材に完全に貼り付けるようにします。

将整条保护纸撕掉,并压平整条灯带,使LED灯带完全粘在木板上。

**3**

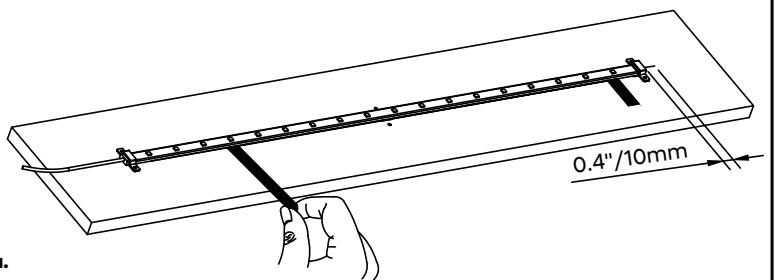

**4** Lock the remaining fixings.

Verrouillez les autres fixations.

Die restlichen Befestigungen anziehen.

Bloccare i restanti elementi di fissaggio.

Bloquee las fijaciones restantes.

나머지 고정 부품을 잠급니다.

残りの固定具を留めます。

锁上剩下的固定件。

**4**

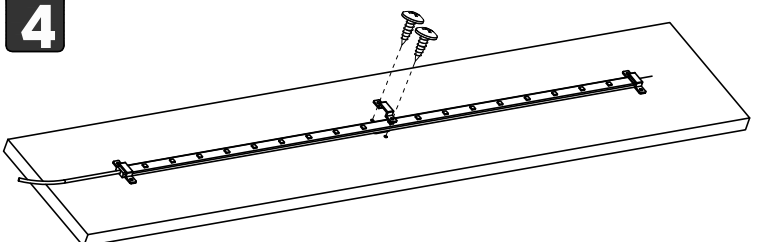

# 1

(B)

• Please refer to "Detailed Installation for LED Strip" on page "8".

• Veuillez consulter "Installation détaillée de la bande LED" sur la page "8".

• Siehe Seite "8" der "Ausführlichen Anbringungsanleitung für LED-Streifen".

(D)

• Fare riferimento a "Installazione dettagliata della striscia LED" a pagina "8".

• Consulte "Instalación detallada de la tira de LED" en la página "8".

• "8"페이지의 LED 램프 상세 설치를 참조하십시오.

• "8"페이지にある"LEDストリップライトの設置に関する詳細説明"を参照してください。

• 请参考第 "8" 页 "LED 灯带安装方法"

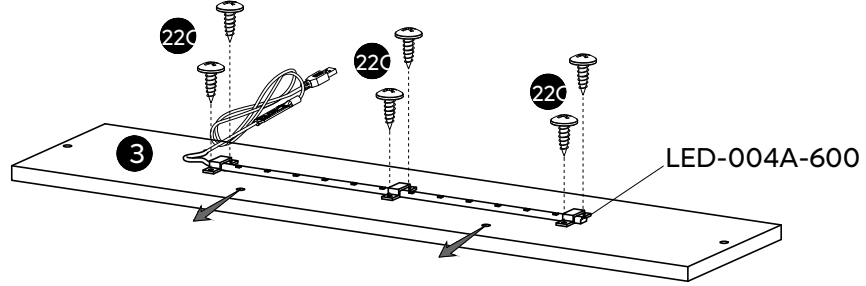

OR(ou/oder/o/o/또는/または/或者)

(A)

(C)

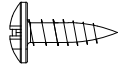
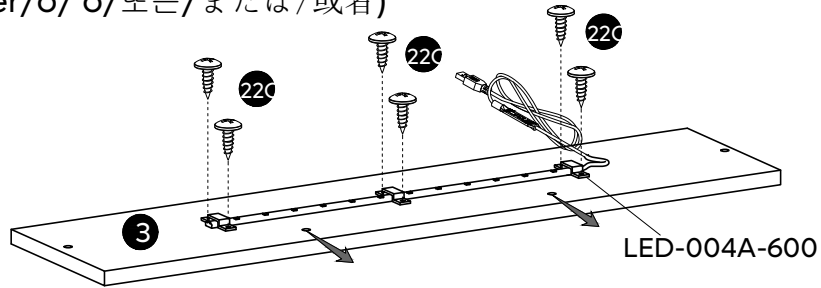

x6

22C ST3.5x10mm

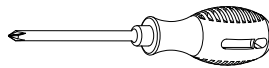

# 2

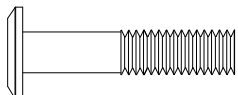
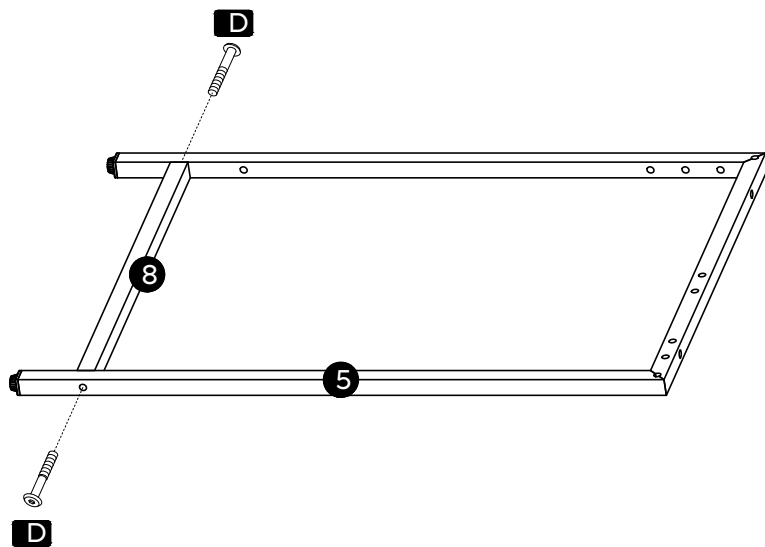



x2

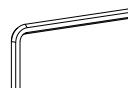

M6x28mm



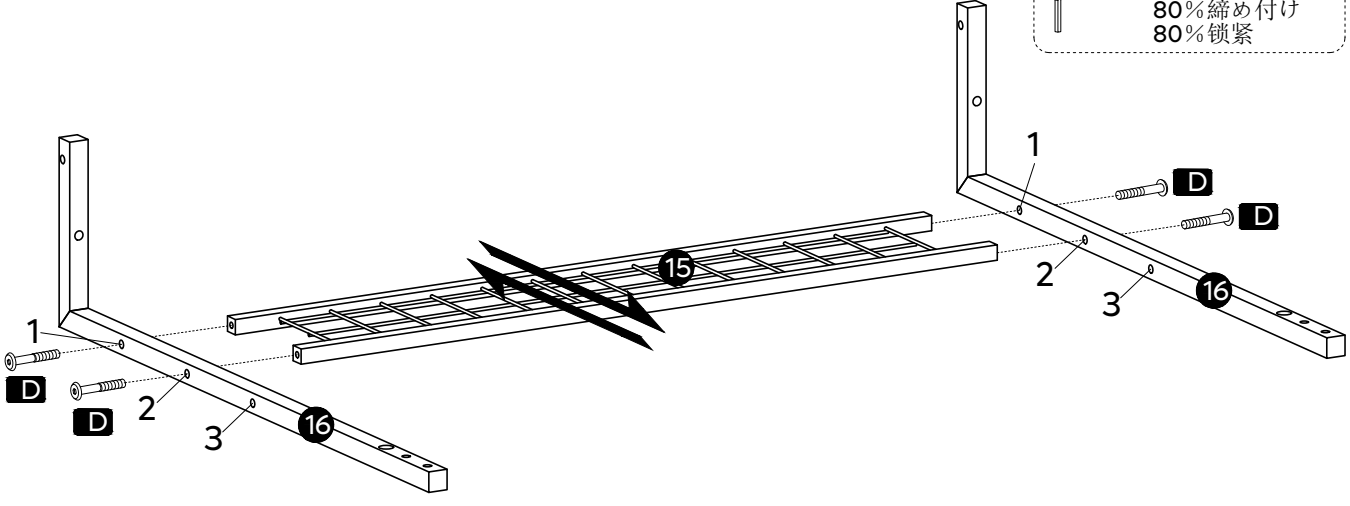

### 3

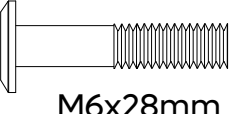
 80% tighten  
 80% serré  
 80% festziehen  
 Serraggio al 80%  
 80% reforzado  
 80% 조임  
 80% 締め付け  
 80% 锁紧



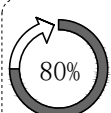

		x4	
<b>D</b>	M6x28mm		

### 4

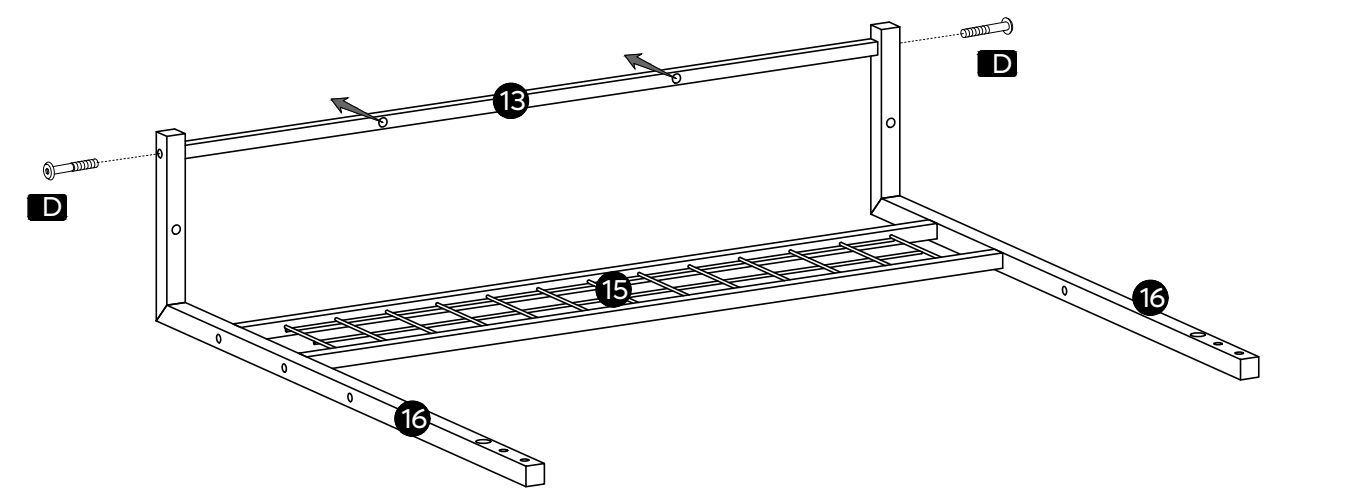
 80% tighten  
 80% serré  
 80% festziehen  
 Serraggio al 80%  
 80% reforzado  
 80% 조임  
 80% 締め付け  
 80% 锁紧

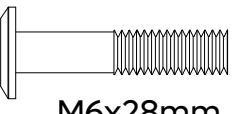

		x2	
<b>D</b>	M6x28mm		

Style A/B: Step 1-4&5-18,33  
Style A/B: Étape 1-4&5-18,33  
Ausführung A/B: Schritt 1-4&5-18,33  
Stile A/B: Step 1-4&5-18,33  
Estilo A/B: paso 1-4&5-18,33  
스타일 A/B: 1-4&5-18,33단계  
スタイル A/B: ステップ 1-4&5-18,33  
安装方式 A/B: 步骤 1-4&5-18,33

(A)

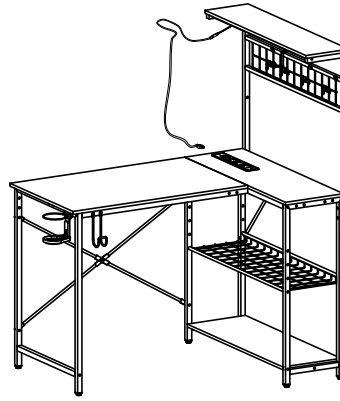

(B)

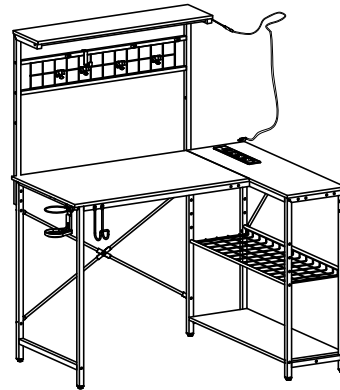

Style C/D: Step 1-4&19-33  
Style C/D: Étape 1-4&19-33  
Ausführung C/D: Schritt 1-4&19-33  
Stile C/D: Step 1-4&19-33  
Estilo C/D: paso 1-4&19-33  
스타일 C/D: 1-4&19-33단계  
スタイル C/D: ステップ 1-4&19-33  
安装方式 C/D: 步骤 1-4&19-33

(C)

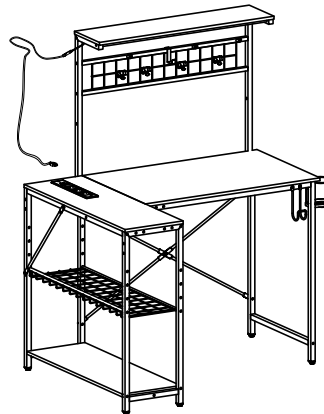

(D)

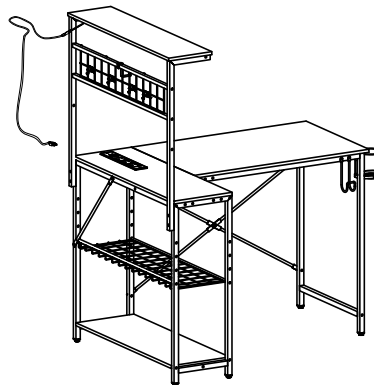

**A**

※Please be careful not to install screws D and E in the wrong position, otherwise the board will be damaged.

※Veuillez faire attention à ne pas installer les vis D et E dans une mauvaise position, au risque d'endommager la carte.

※Bitte achten Sie darauf, dass die Schrauben D und E nicht in der falschen Position eingeschraubt werden, da sonst die Platine beschädigt wird.

※Si prega di fare attenzione a non installare le viti D e E nella posizione sbagliata, altrimenti la scheda sarà danneggiata.

※Asegúrese de no instalar los tornillos D y E en la posición incorrecta, de lo contrario la placa se dañará.

※스크류 D와 E를 잘못된 위치에 설치하지 마십시오. 그렇지 않으면 회로 기판이 손상될 수 있습니다.

※ネジDとEを間違った位置に差し込まないように注意してください。そうでないと、基板が破損します。

※请注意不要将螺丝D和E安装在错误位置，否则会损坏木板。

- ※ Two persons are needed.
- ※ Deux personnes sont nécessaires.
- ※ Zwei Personen sind erforderlich.
- ※ Sono necessarie due persone.
- ※ Se necesitan dos personas.
- ※ 두 사람이 필요합니다.
- ※ 必ず2人で作業してください。
- ※ 需要另1个人协助。

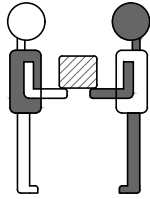

- 100% tighten
- 100% serré
- 100% festziehen
- Serraggio al 100%
- 100% reforzado
- 100% 조임
- 100%締め付け
- 100%锁紧

- ※Fully tighten all screws.
- ※Serrez complètement toutes les vis.
- ※Ziehen Sie alle Schrauben vollständig an.
- ※Serrare completamente tutte le viti.
- ※Apriete a tope los tornillos.
- ※모든 나사를 완전히 조입니다.
- ※すべてのネジをしっかり締める。
- ※锁紧全部螺丝

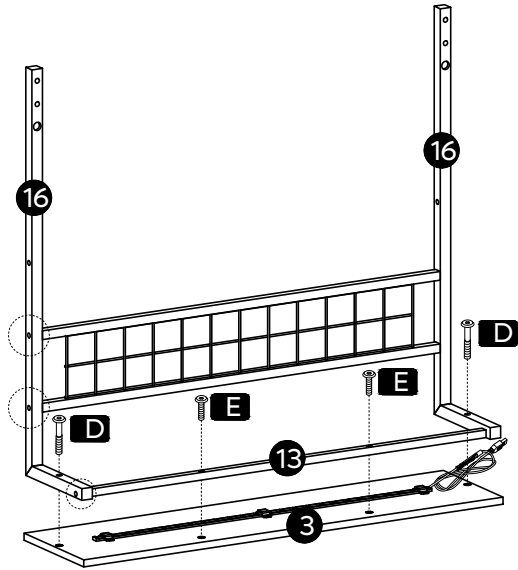

**B** OR(ou/oder/o/o/또는/または/或者)

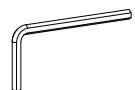
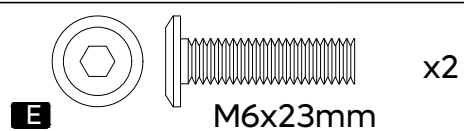
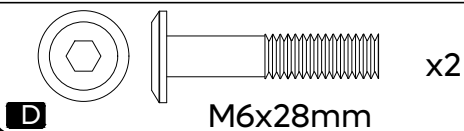
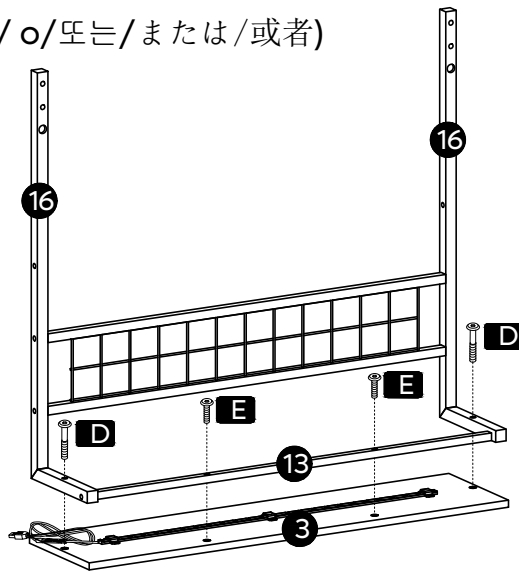

# 6

(A)

(B)

80% tighten  
 80% serré  
 80% festziehen  
 Serraggio al 80%  
 80% reforzado  
 80% 조임  
 80% 締め付け  
 80% 锁紧

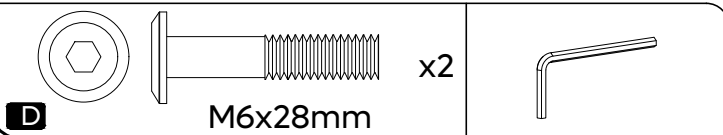
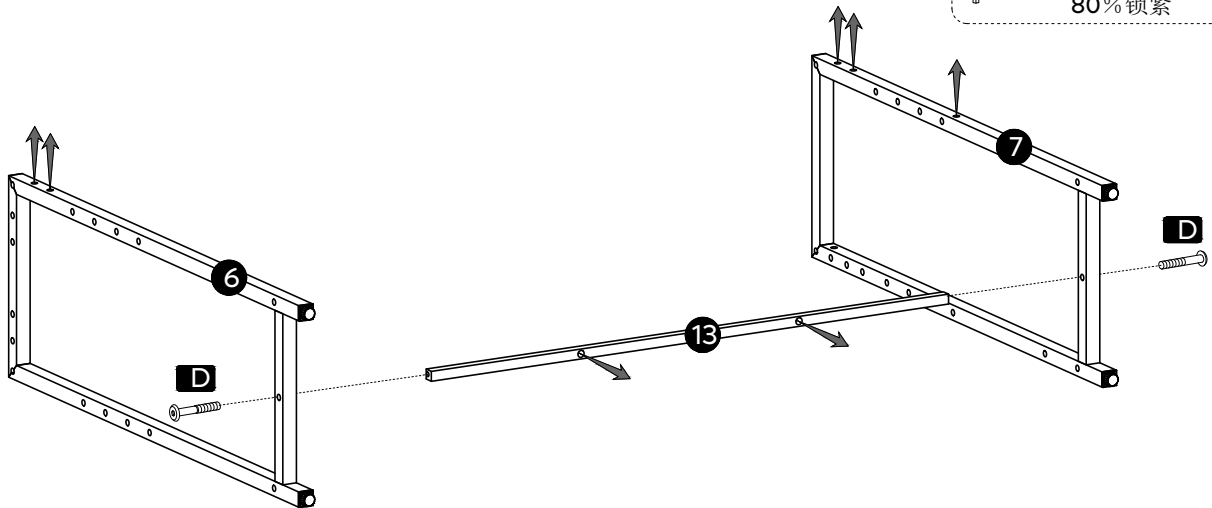

# 7

(A)

(B)

100% tighten  
 100% serré  
 100% festziehen  
 Serraggio al 100%  
 100% reforzado  
 100% 조임  
 100% 締め付け  
 100% 锁紧

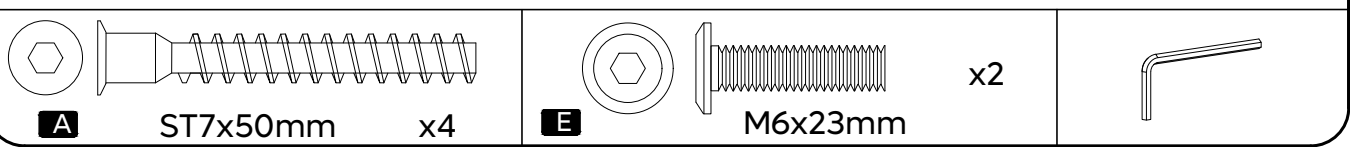
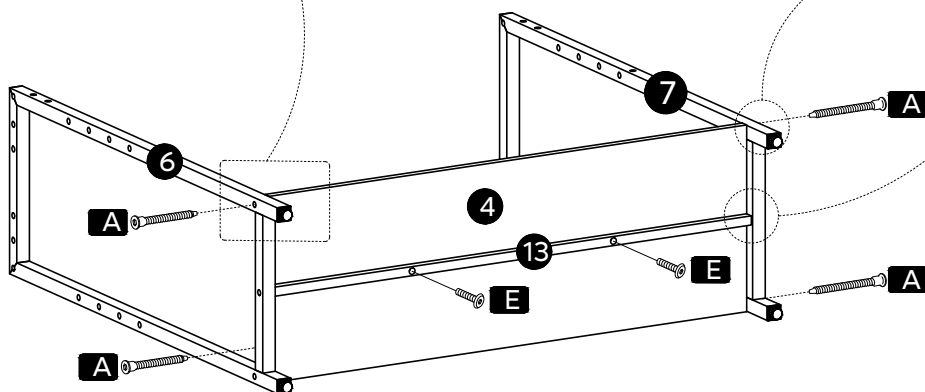
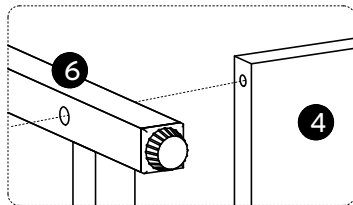

(A)

(B)

80% tighten  
 80% serré  
 80% festziehen  
 Serraggio al 80%  
 80% reforzado  
 80% 조임  
 80% 締め付け  
 80% 锁紧

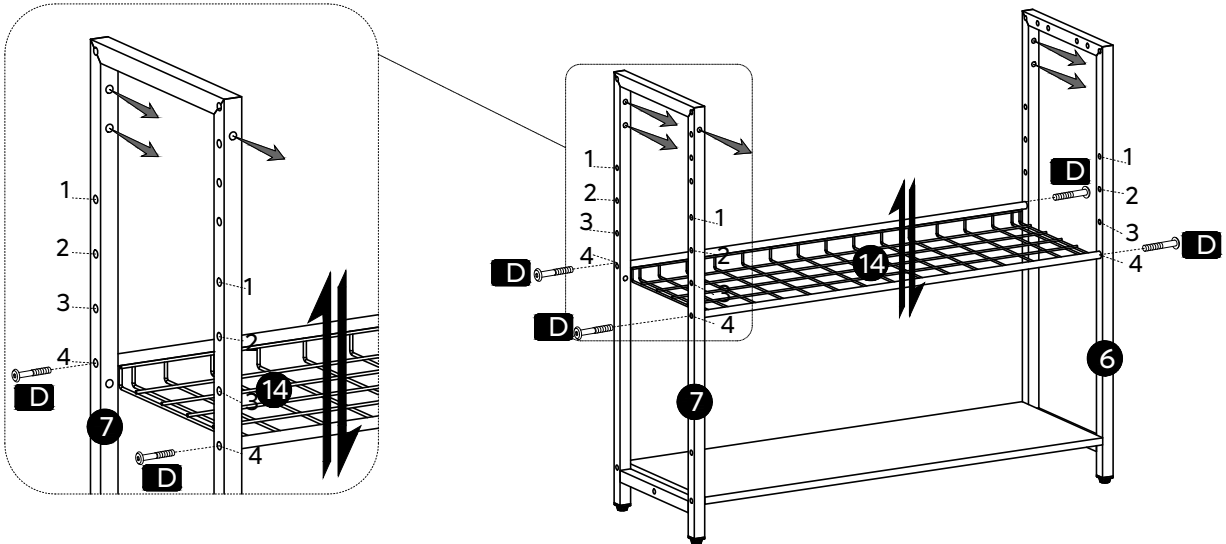

OR(ou/oder/o/o/또는/または/或者)

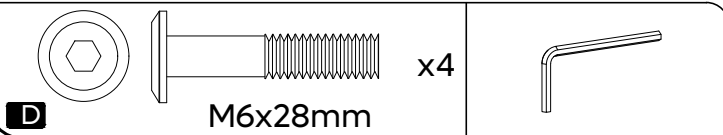
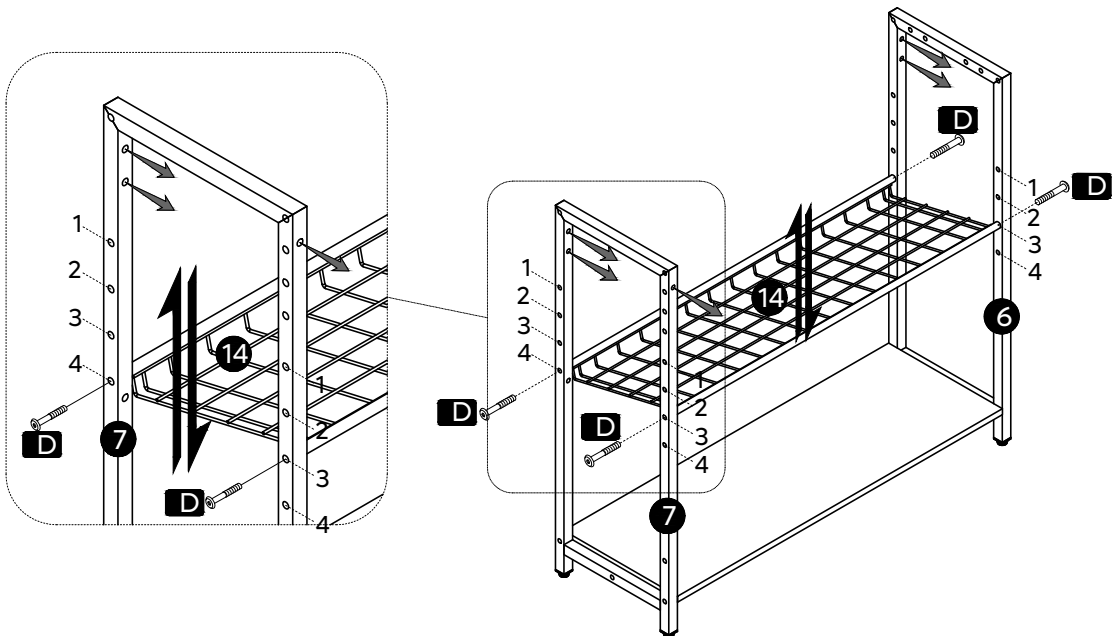

# 9

(A)

(B)

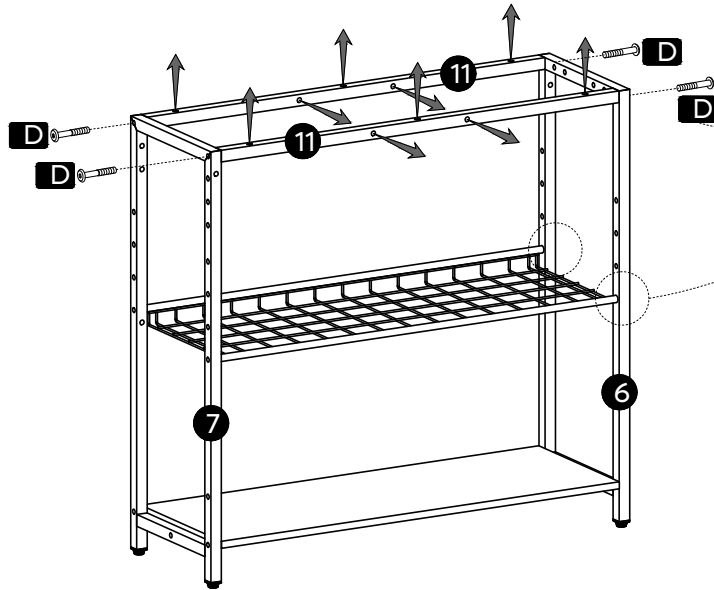

100% tighten  
 100% serré  
 100% festziehen  
 Serraggio al 100%  
 100% reforzado  
 100% 조임  
 100% 締め付け  
 100% 锁紧

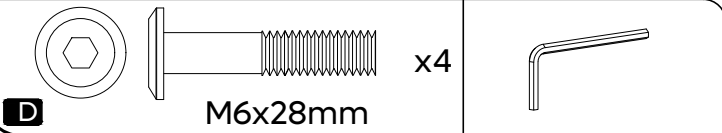

# 10

(A)

(B)

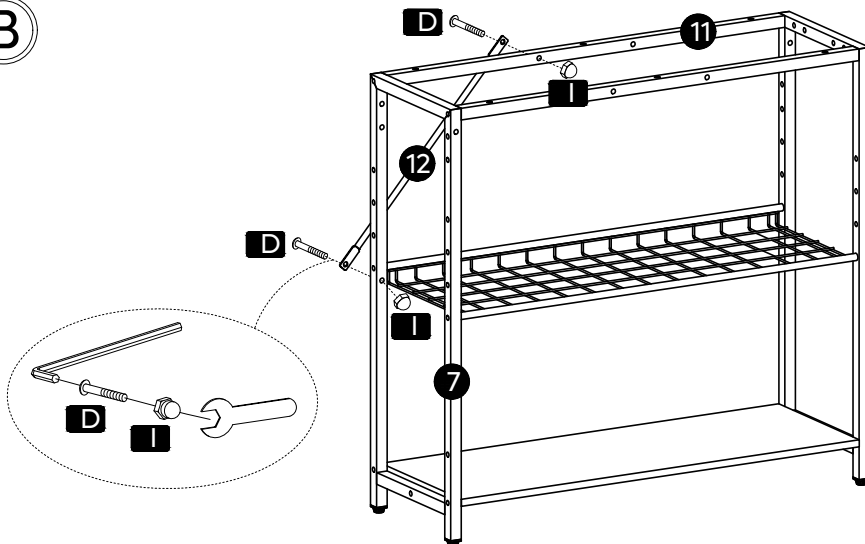

100% tighten  
 100% serré  
 100% festziehen  
 Serraggio al 100%  
 100% reforzado  
 100% 조임  
 100% 締め付け  
 100% 锁紧

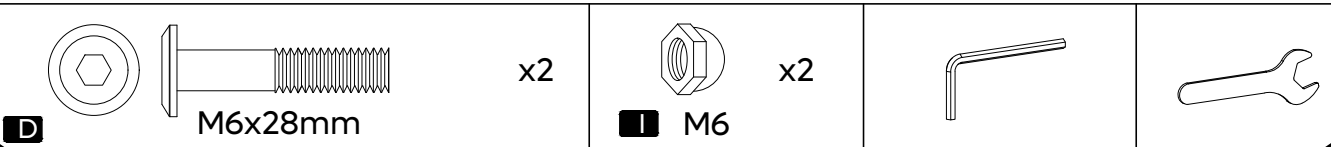

# 11

(A)

(B)

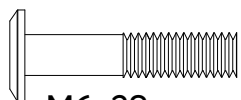
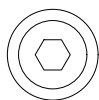
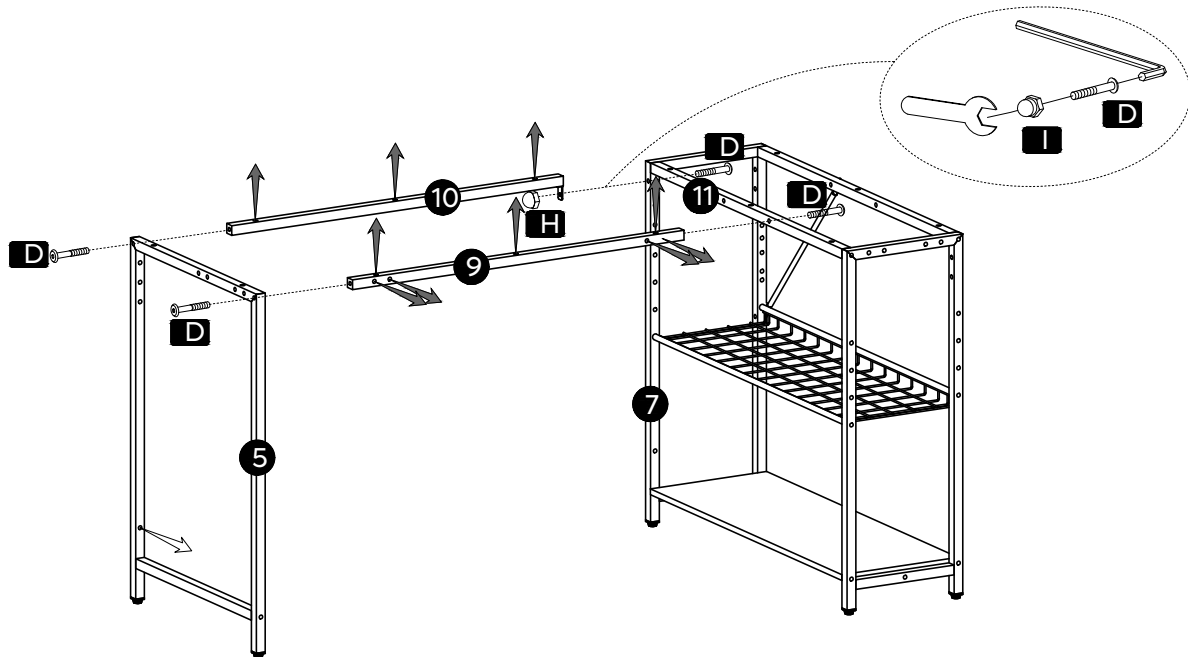

M6x28mm

x4



x1

M6

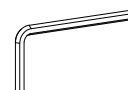

# 12

(A)

(B)

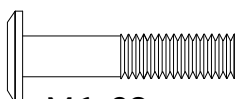
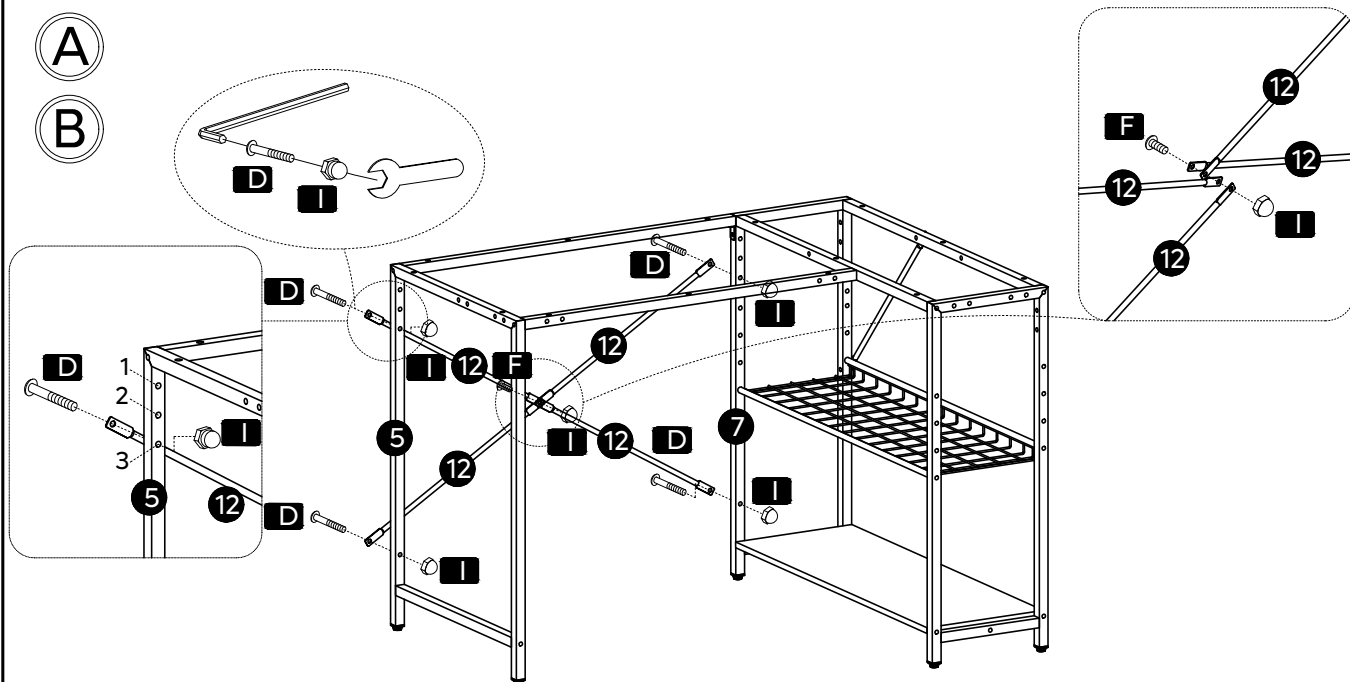

M6x28mm

x4

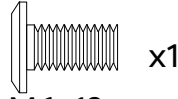
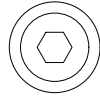

x1

M6x12mm



x5

M6

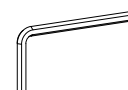

# 13

OR(ou/oder/o/o/또는/または/或者)

(A)

(B)

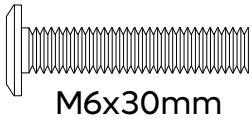
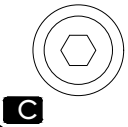
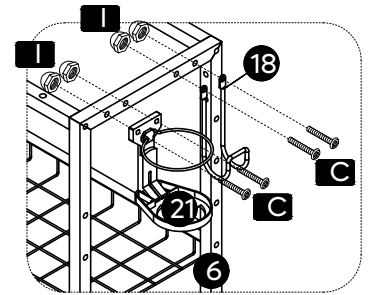
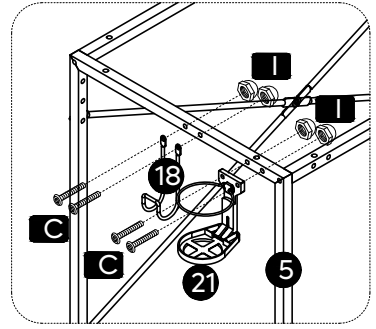
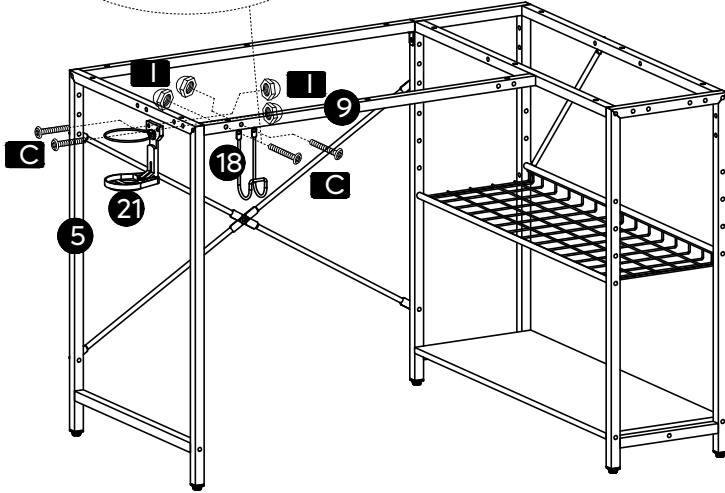
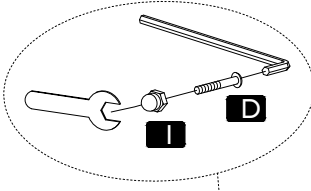

x4



x4

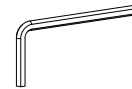

# 14

(A)

(B)

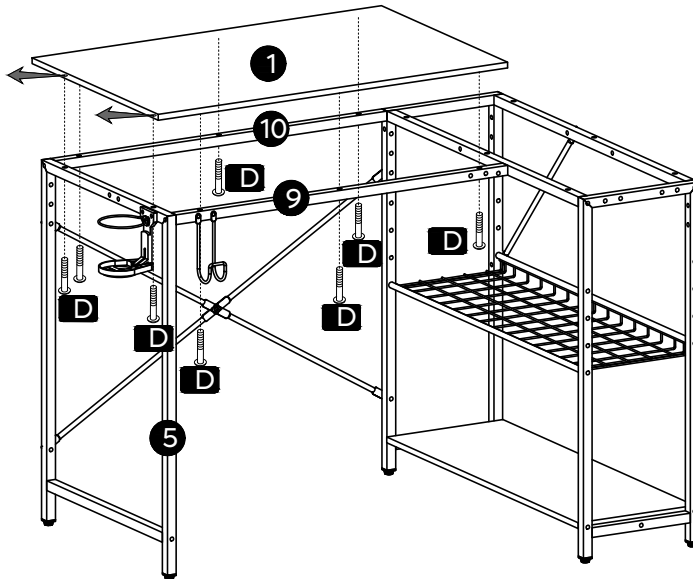

80% tighten  
 80% serré  
 80% festziehen  
 Serraggio al 80%  
 80% reforzado  
 80% 조임  
 80% 締め付け  
 80% 锁紧

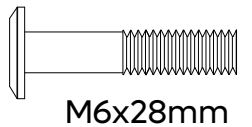
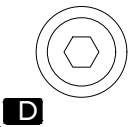

x8

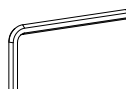

# 15

A

B

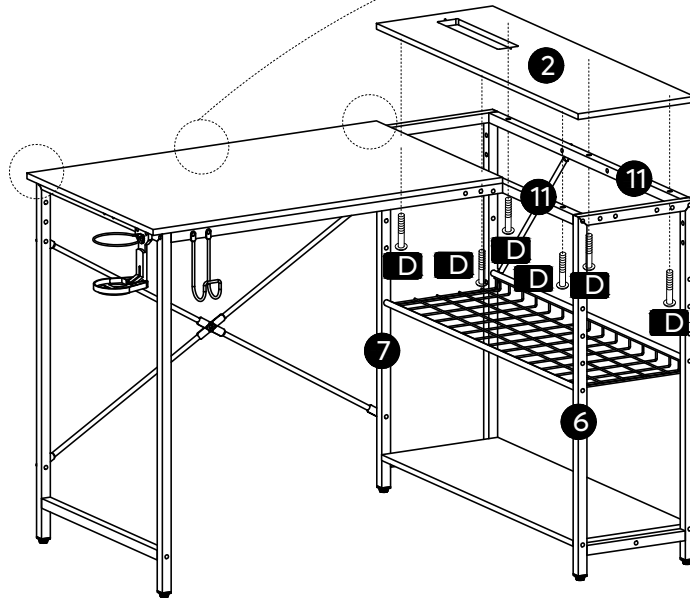

100% tighten  
 100% serré  
 100% festziehen  
 Serraggio al 100%  
 100% reforzado  
 100% 조임  
 100% 締め付け  
 100% 锁紧

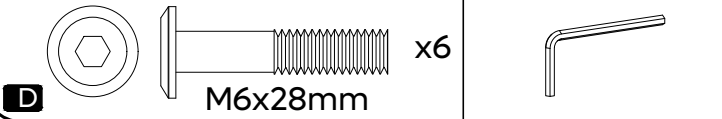

# 16

A

B

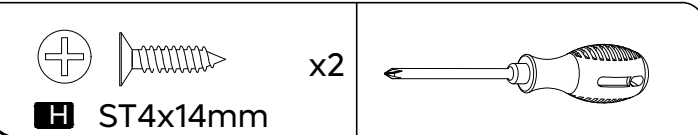
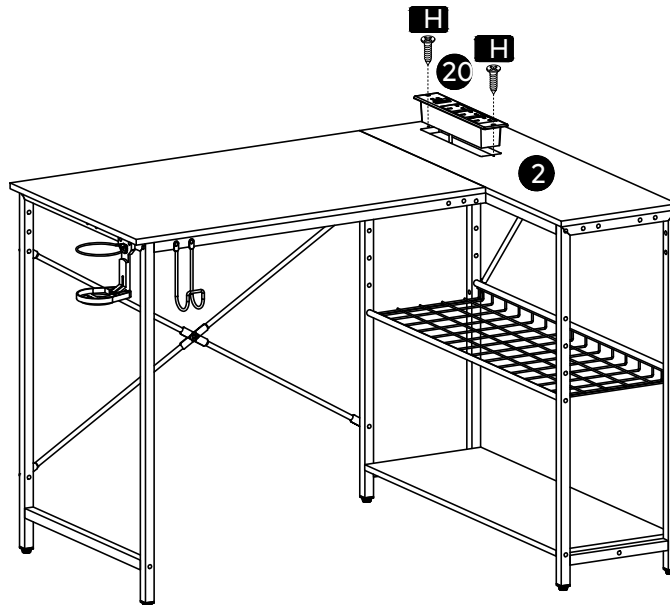

- ※ Two persons are needed.
- ※ Deux personnes sont nécessaires.
- ※ Zwei Personen sind erforderlich.
- ※ Sono necessarie due persone.
- ※ Se necesitan dos personas.
- ※ 두 사람이 필요합니다.
- ※ 必ず2人で作業してください。
- ※ 需要另1个人协助。

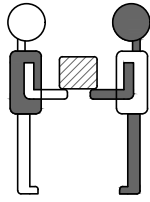

**A**

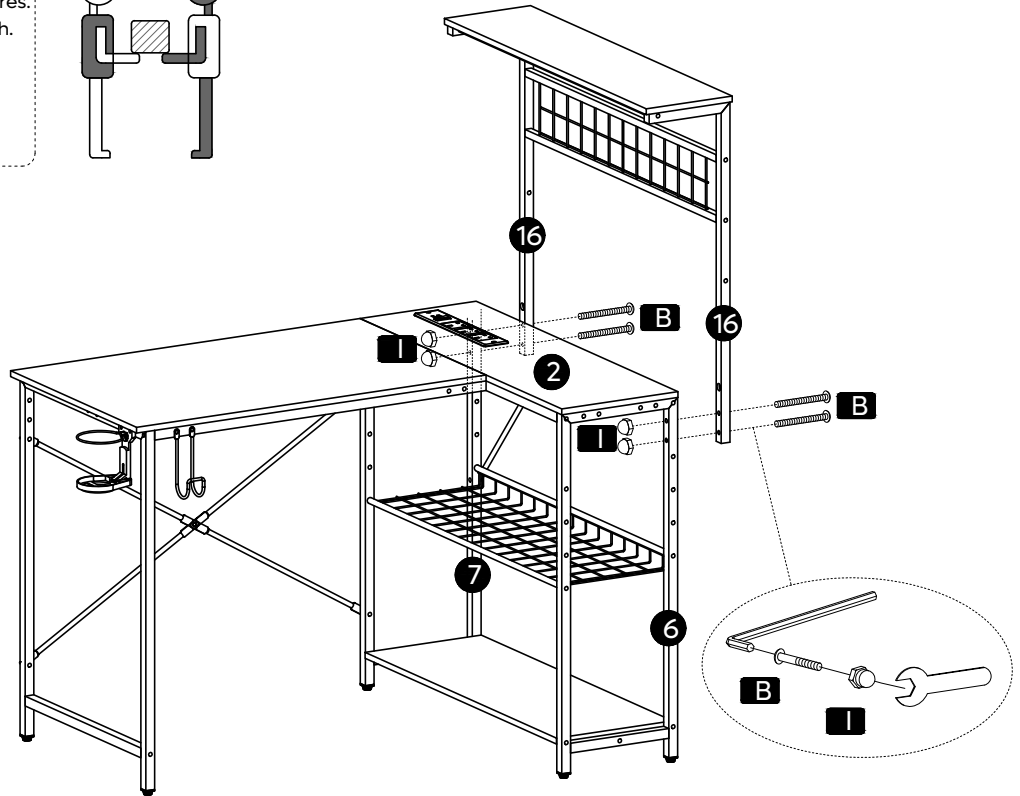

**B**

OR(ou/oder/o/ o/또는/または/或者)

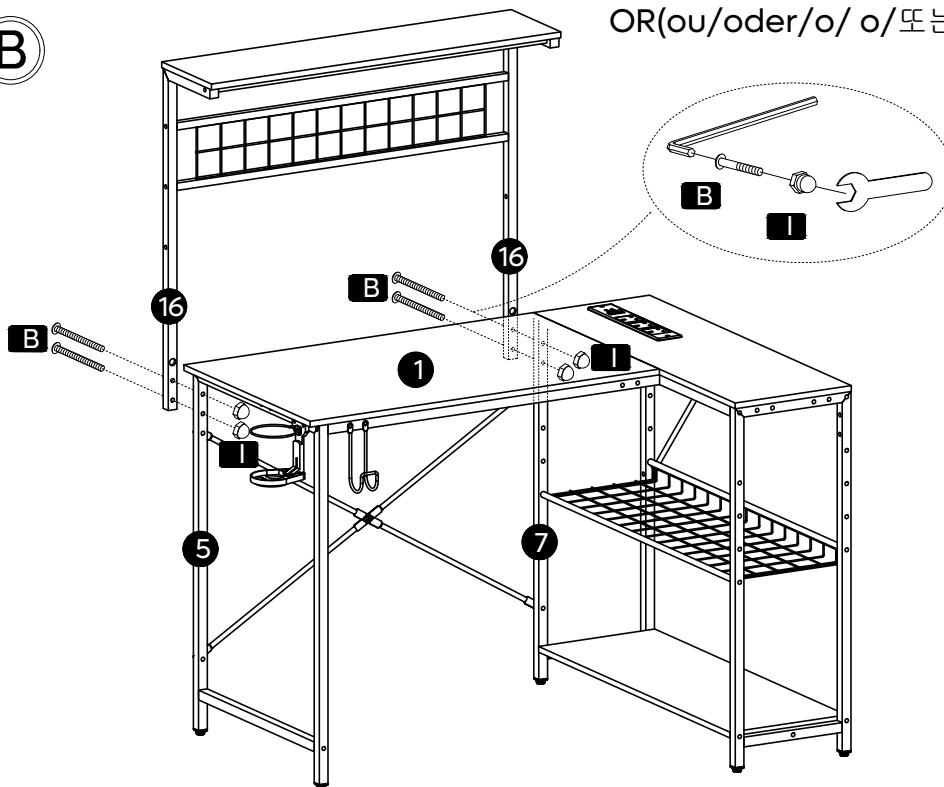

**B**

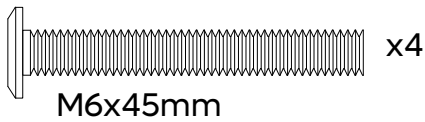

**I** M6

x4

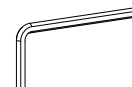

A

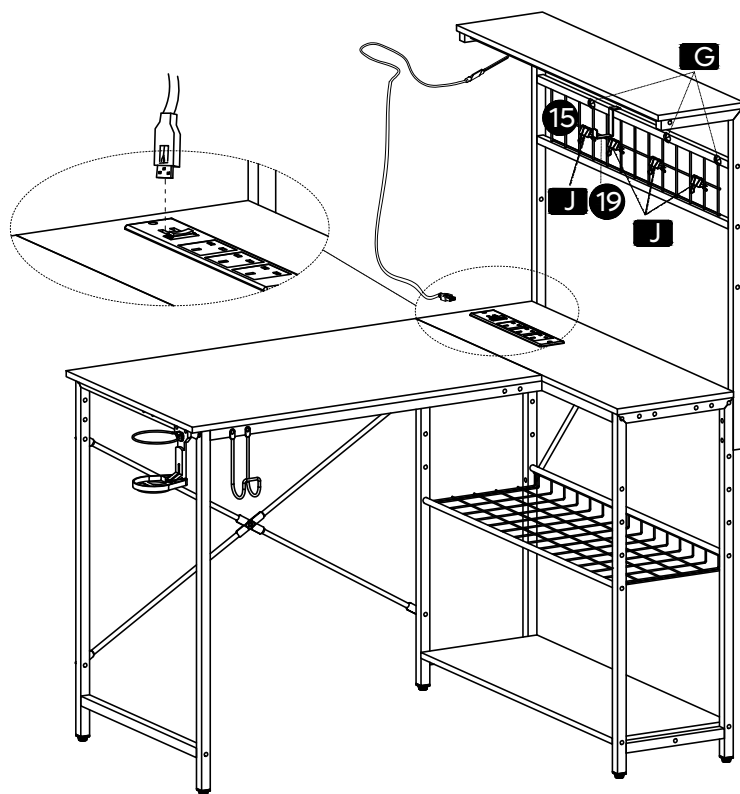

OR(ou/oder/o/ o/또는/または/或者)

B

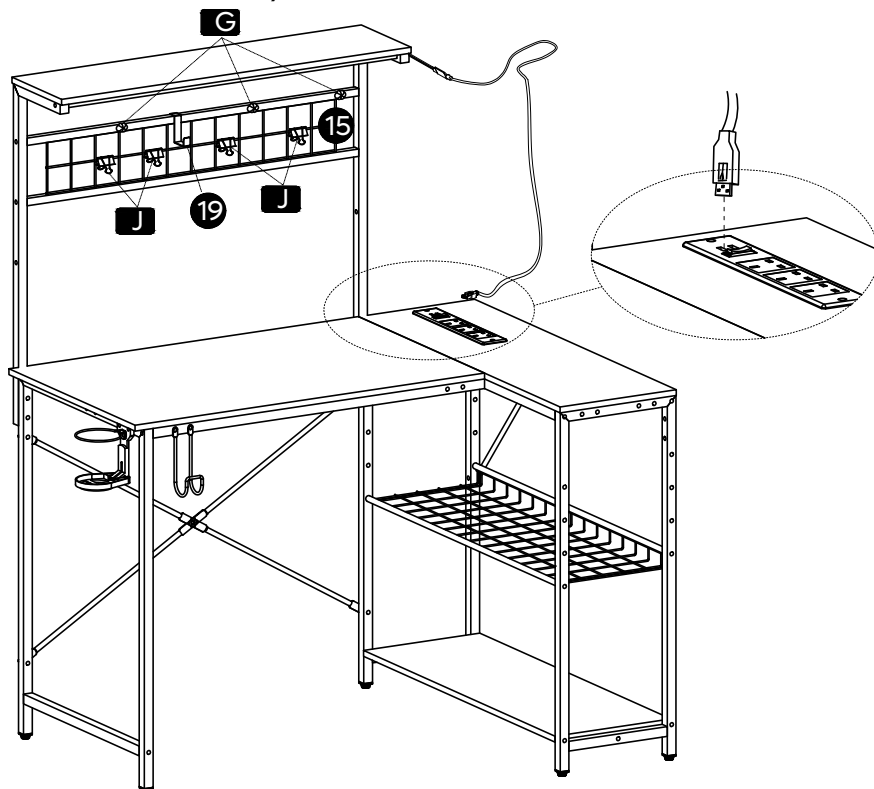

x4



x3

C

※Please be careful not to install screws D and E in the wrong position, otherwise the board will be damaged.

※Veuillez faire attention à ne pas installer les vis D et E dans une mauvaise position, au risque d'endommager la carte.

※Bitte achten Sie darauf, dass die Schrauben D und E nicht in der falschen Position eingeschraubt werden, da sonst die Platine beschädigt wird.

※Si prega di fare attenzione a non installare le viti D e E nella posizione sbagliata, altrimenti la scheda sarà danneggiata.

※Asegúrese de no instalar los tornillos D y E en la posición incorrecta, de lo contrario la placa se dañará.

※스크류 D와 E를 잘못된 위치에 설치하지 마십시오. 그렇지 않으면 회로 기판이 손상될 수 있습니다.

※ネジDとEを間違った位置に差し込まないように注意してください。そうでないと、基板が破損します。

※请注意不要将螺丝D和E安装在错误位置，否则会损坏木板。

- ※ Two persons are needed.
- ※ Deux personnes sont nécessaires.
- ※ Zwei Personen sind erforderlich.
- ※ Sono necessarie due persone.
- ※ Se necesitan dos personas.
- ※ 두 사람이 필요합니다.
- ※ 必ず2人で作業してください。
- ※ 需要另1个人协助。

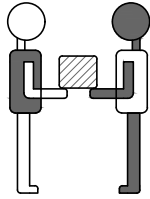

- 100% tighten
- 100% serré
- 100% festziehen
- Serraggio al 100%
- 100% reforzado
- 100% 조임
- 100%締め付け
- 100%锁紧

- ※Fully tighten all screws.
- ※Serrez complètement toutes les vis.
- ※Ziehen Sie alle Schrauben vollständig an.
- ※Serrare completamente tutte le viti.
- ※Apriete a tope los tornillos.
- ※모든 나사를 완전히 조입니다.
- ※すべてのネジをしっかり締める。
- ※锁紧全部螺丝

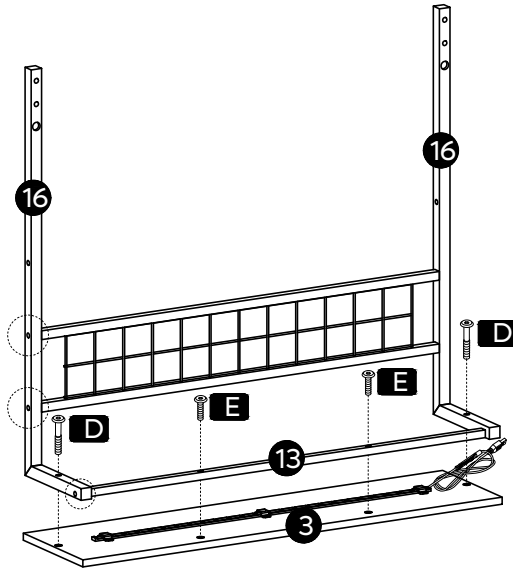

D OR(ou/oder/o/o/또는/または/或者)

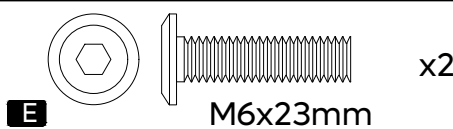
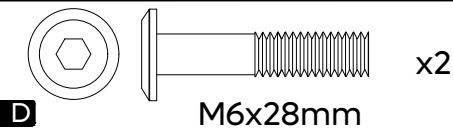
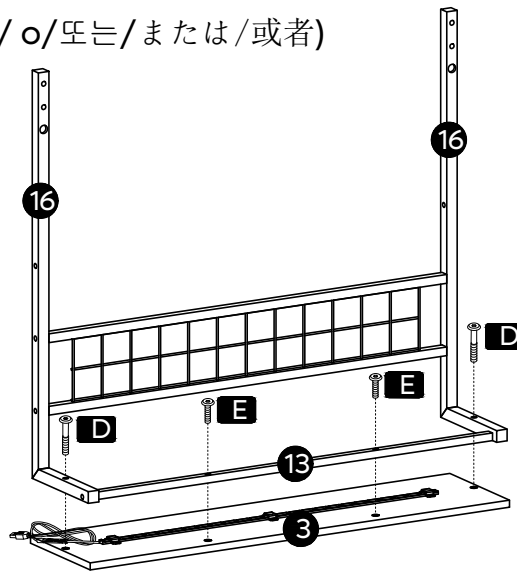

# 20

(C)

(D)

80% tighten  
 80% serré  
 80% festziehen  
 Serraggio al 80%  
 80% reforzado  
 80% 조임  
 80% 締め付け  
 80% 锁紧

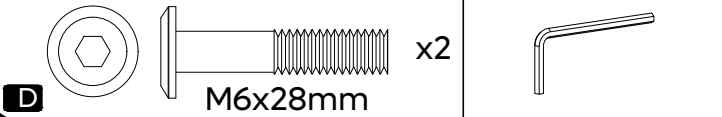
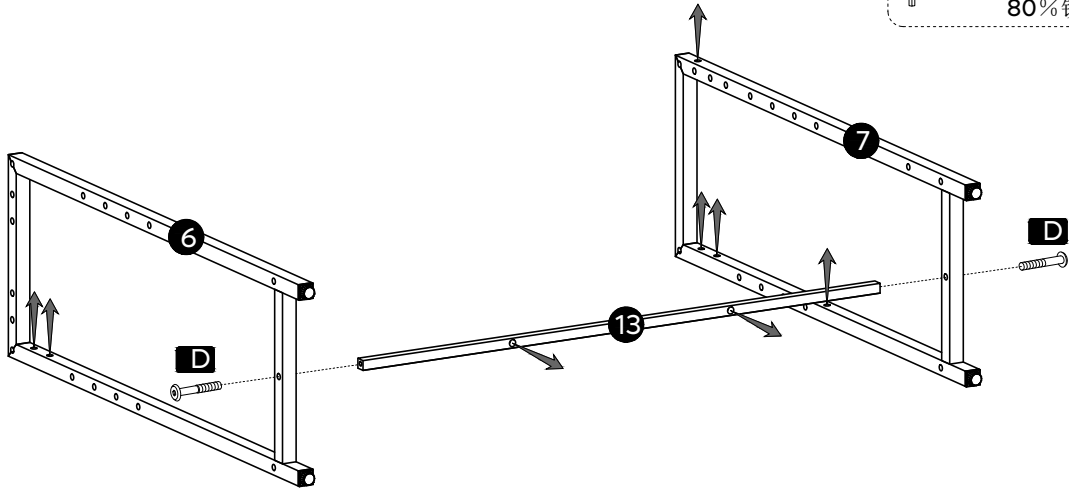

# 21

(C)

(D)

100% tighten  
 100% serré  
 100% festziehen  
 Serraggio al 100%  
 100% reforzado  
 100% 조임  
 100% 締め付け  
 100% 锁紧

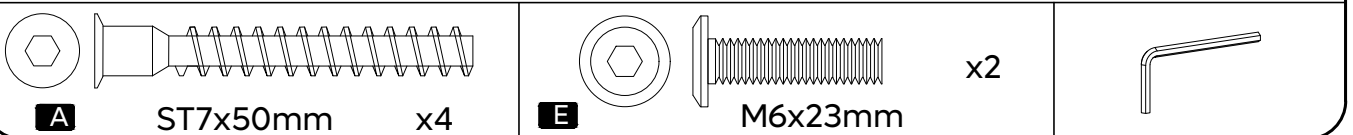
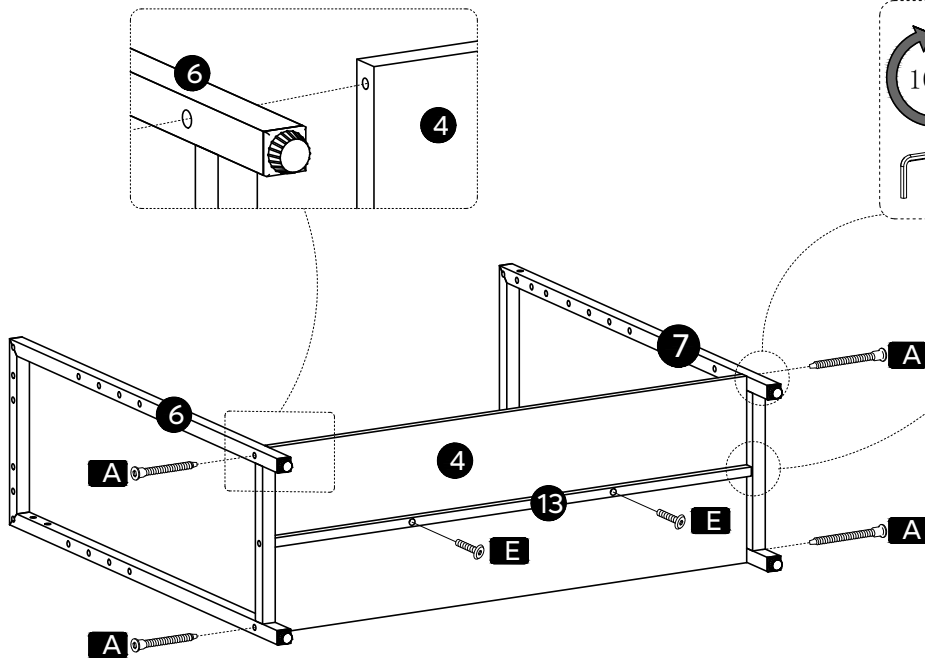

C

D

80% tighten  
 80% serré  
 80% festziehen  
 Serraggio al 80%  
 80% reforzado  
 80% 조임  
 80% 締め付け  
 80% 锁紧

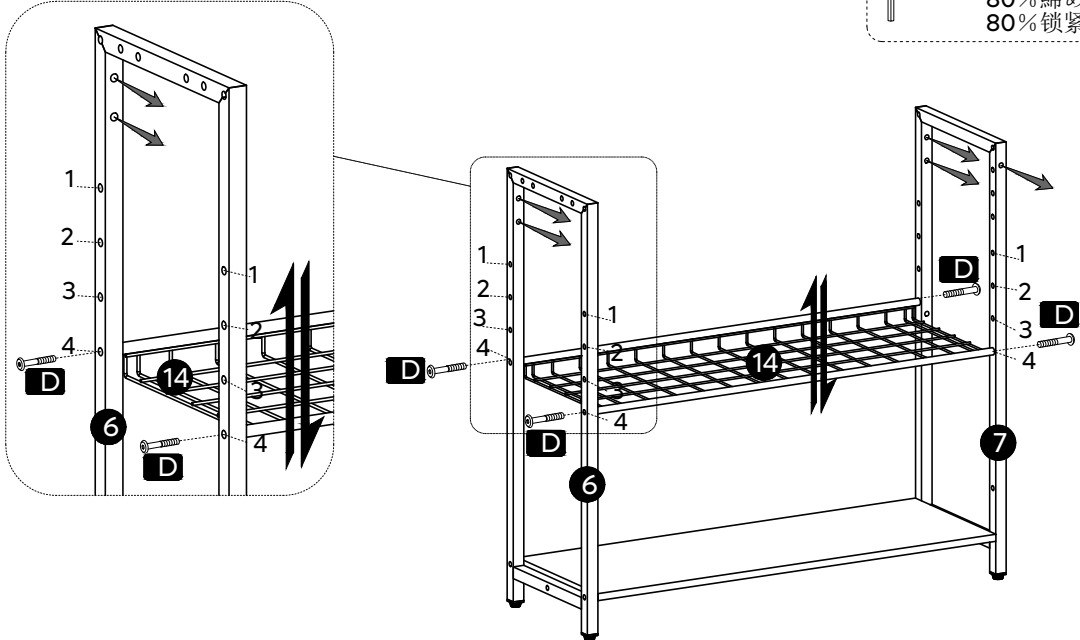

OR(ou/oder/o/o/또는/または/或者)

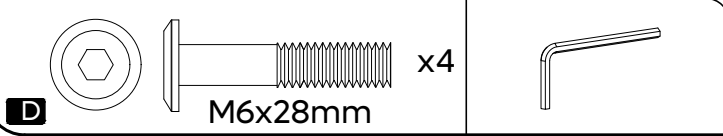
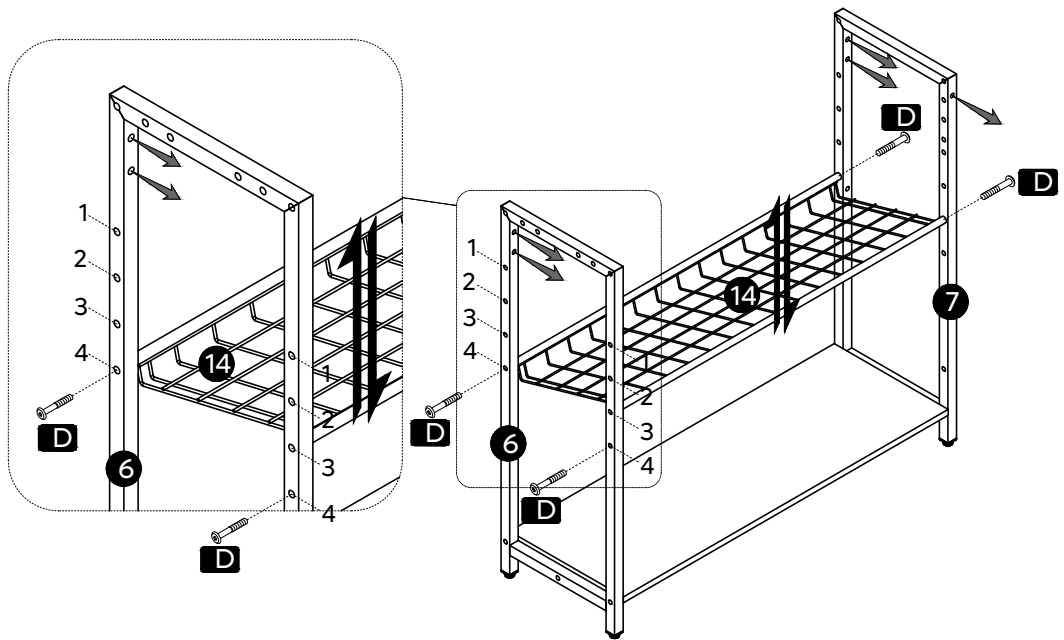

# 23

(C)

(D)

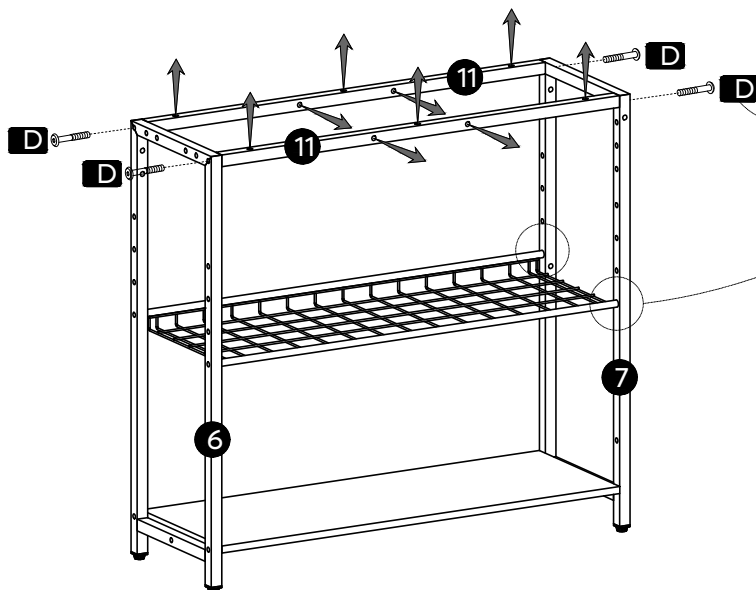

100% tighten  
100% serré  
100% festziehen  
Serraggio al 100%  
100% reforzado  
100% 조임  
100%締め付け  
100%锁紧

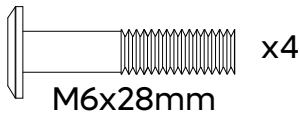

(D)

M6x28mm

# 24

(C)

(D)

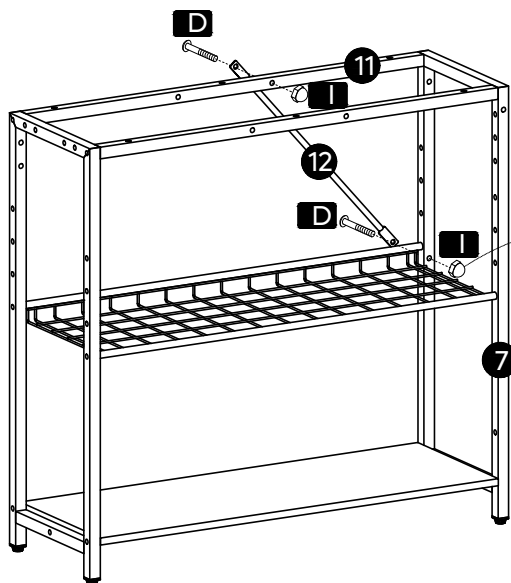

100% tighten  
100% serré  
100% festziehen  
Serraggio al 100%  
100% reforzado  
100% 조임  
100%締め付け  
100%锁紧

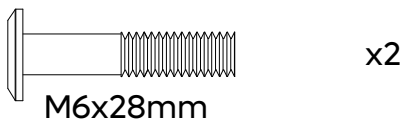
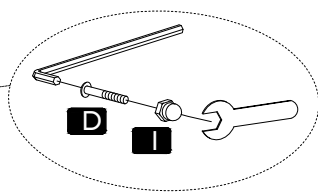

(I) M6

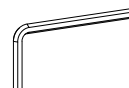

(D)

M6x28mm

x2

x2

# 25

(C)

(D)

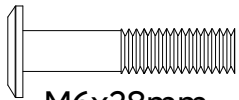
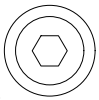
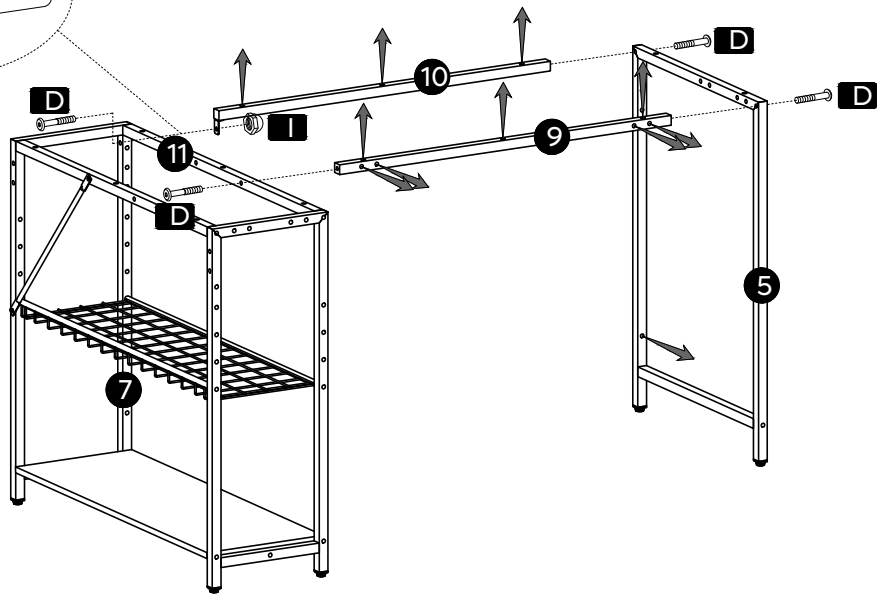
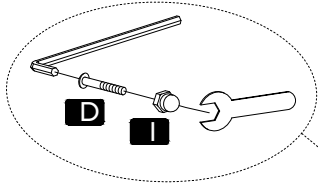

x4

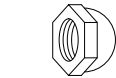

x1

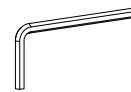

(D)

M6x28mm

(I) M6

# 26

(C)

(D)

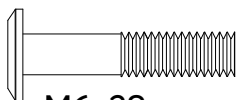
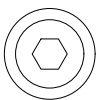
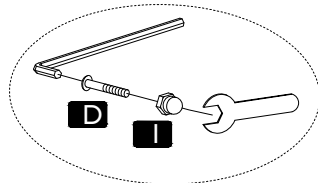
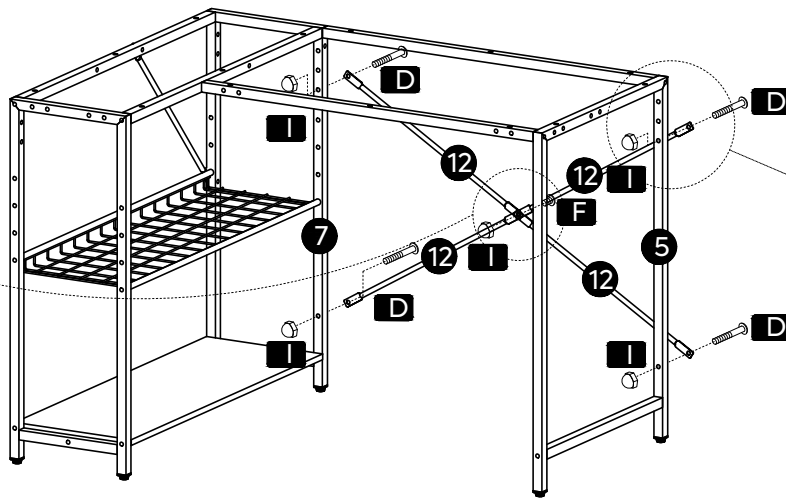
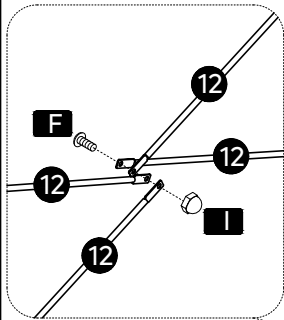

x4

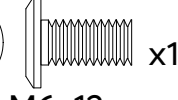
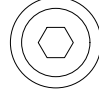

x1



x5

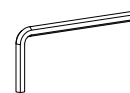

(D)

M6x28mm

(F)

M6x12mm

(I) M6

# 27

C

D

OR(ou/oder/o/o/또는/または/或者)

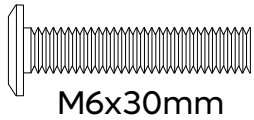
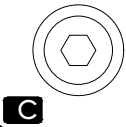
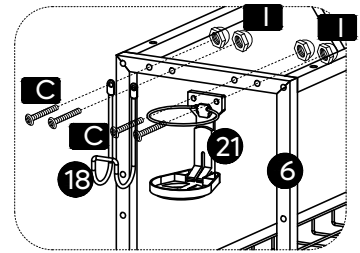
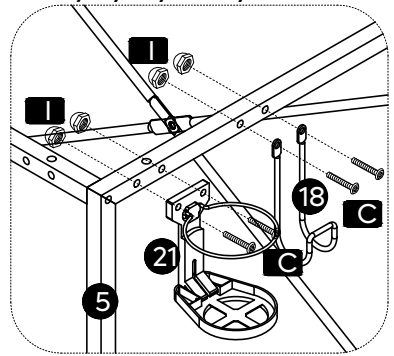
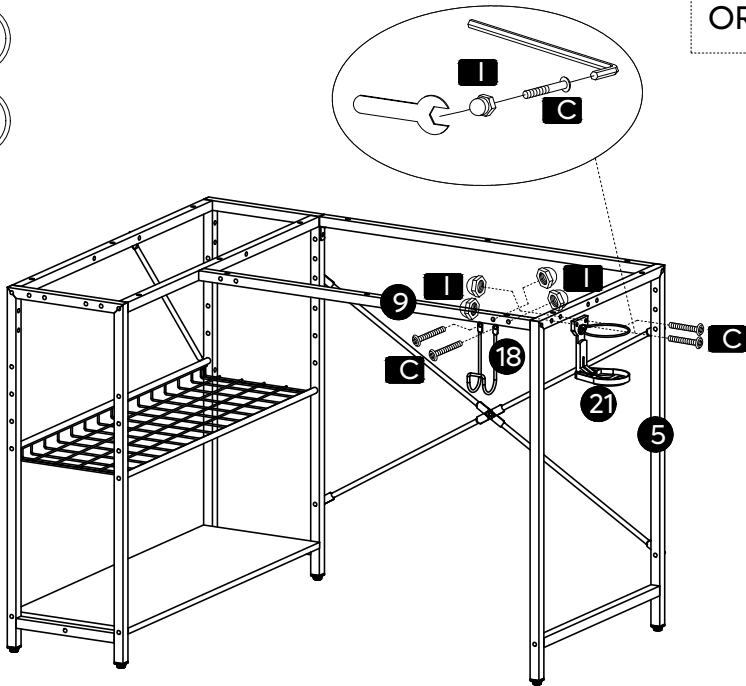

x4

M6x30mm



x4

M6

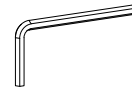

# 28

C

D

80% tighten  
80% serré  
80% festziehen  
Serraggio al 80%  
80% reforzado  
80% 조임  
80% 締め付け  
80% 锁紧

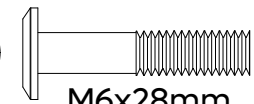
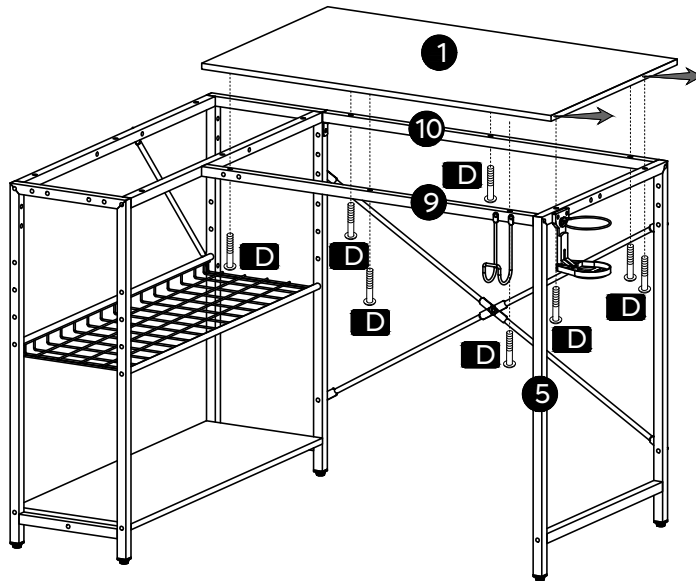

x8

M6x28mm

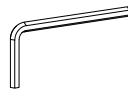

C

D

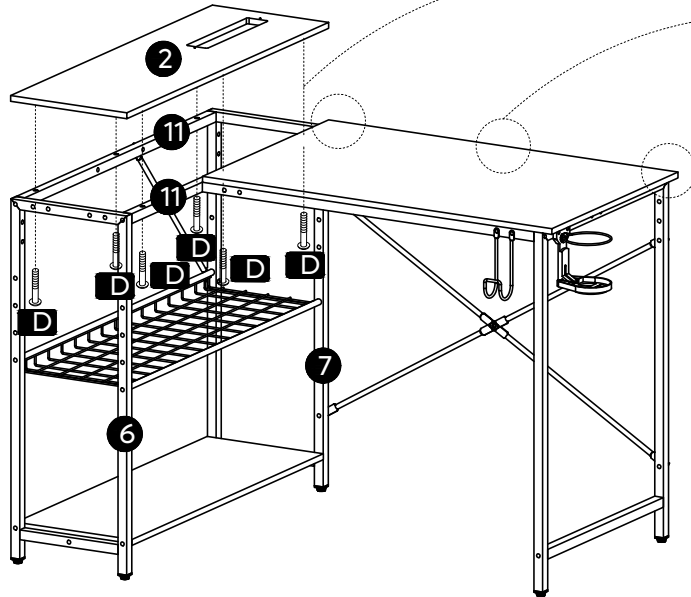

100% tighten  
 100% serré  
 100% festziehen  
 Serraggio al 100%  
 100% reforzado  
 100% 조임  
 100% 締め付け  
 100% 锁紧

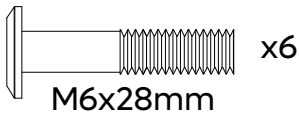

x6

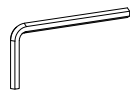

C

D

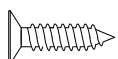
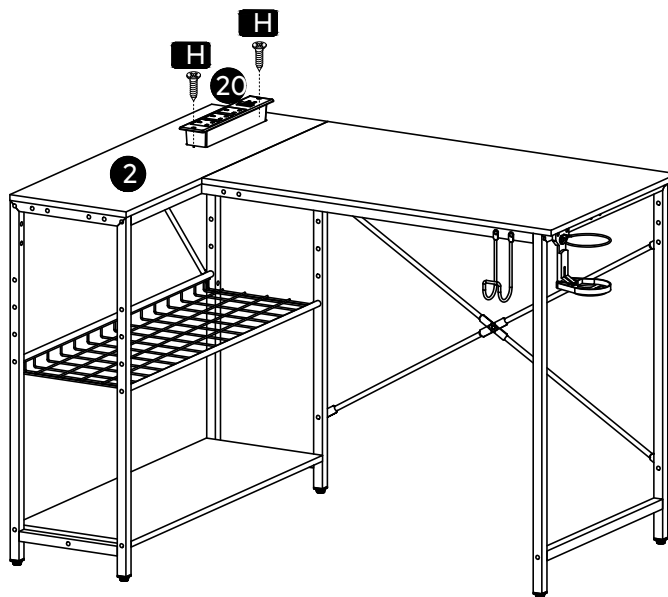

x2

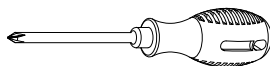

H ST4x14mm

# 31

- ※ Two persons are needed.
- ※ Deux personnes sont nécessaires.
- ※ Zwei Personen sind erforderlich.
- ※ Sono necessarie due persone.
- ※ Se necesitan dos personas.
- ※ 두 사람이 필요합니다.
- ※ 必ず2人で作業してください。
- ※ 需要另1个人协助。

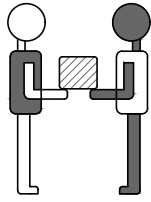

**C**

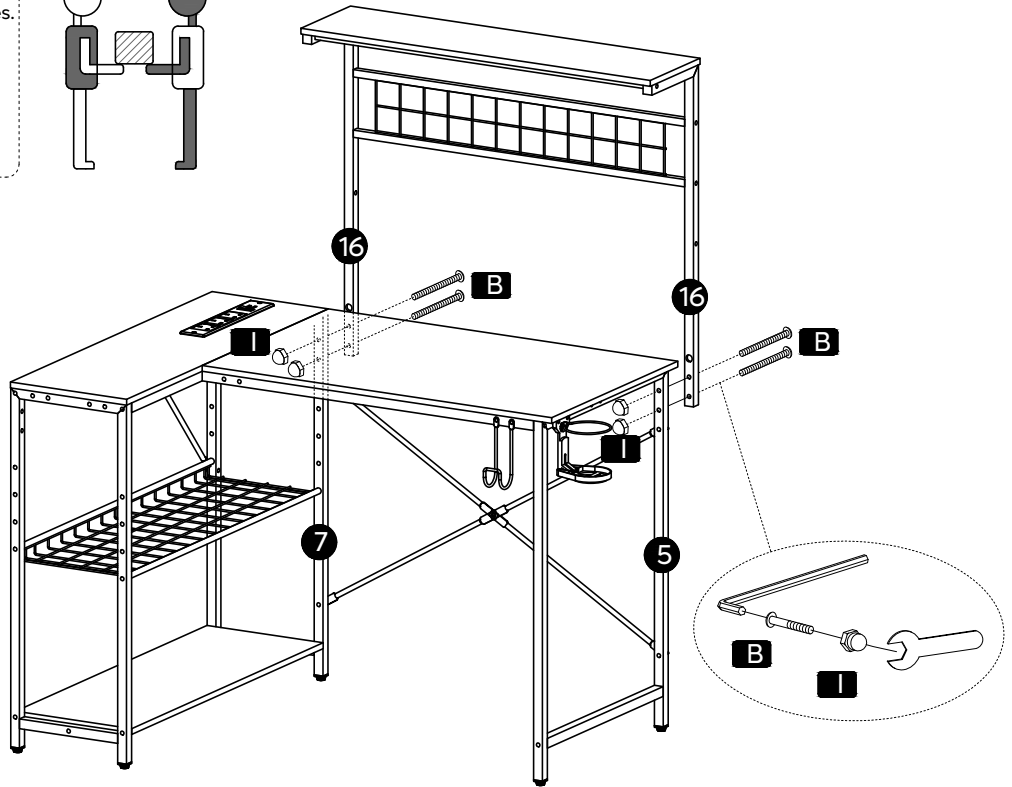

**D**

OR(ou/oder/o/ o/또는/または/或者)

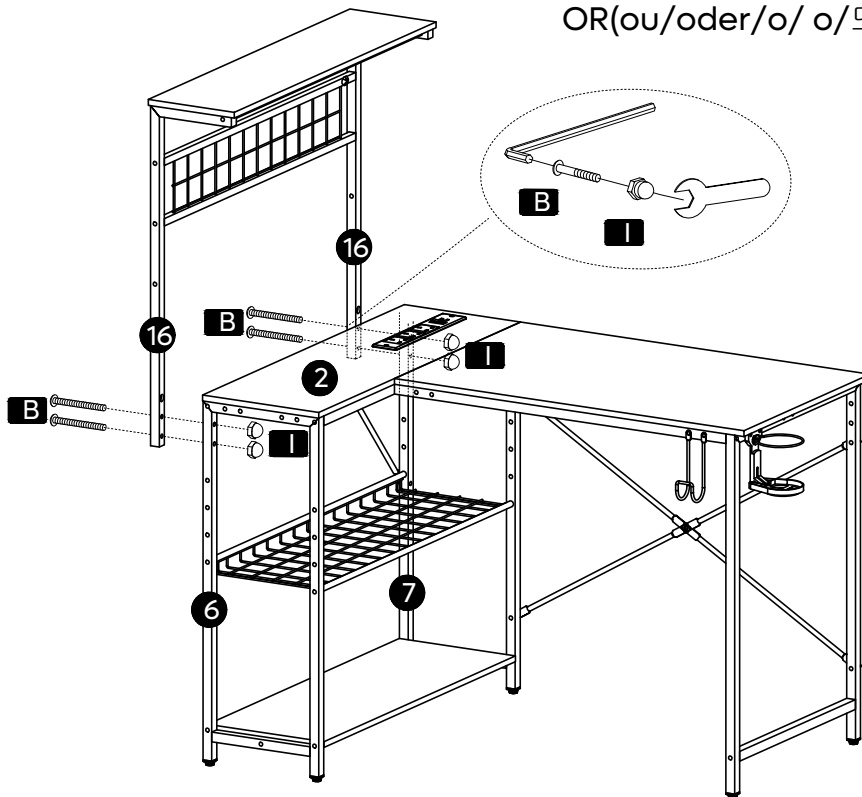

**B**

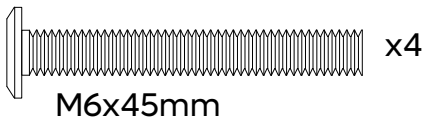

M6x45mm

x4



**I**

M6

x4

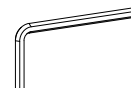

C

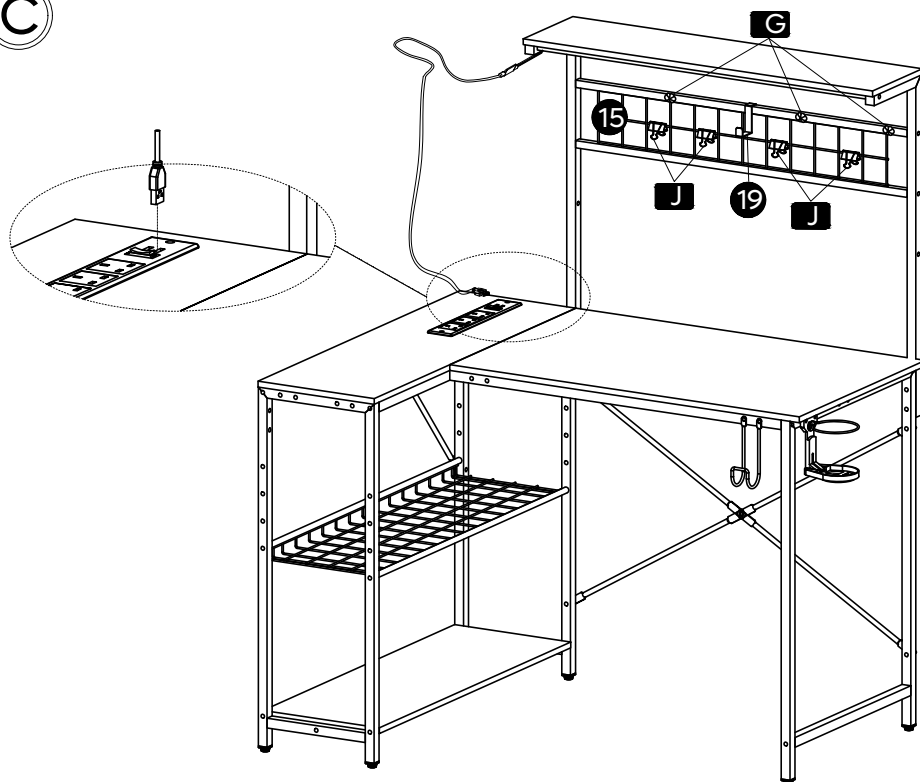

OR(ou/oder/o/ o/또는/または/或者)

D

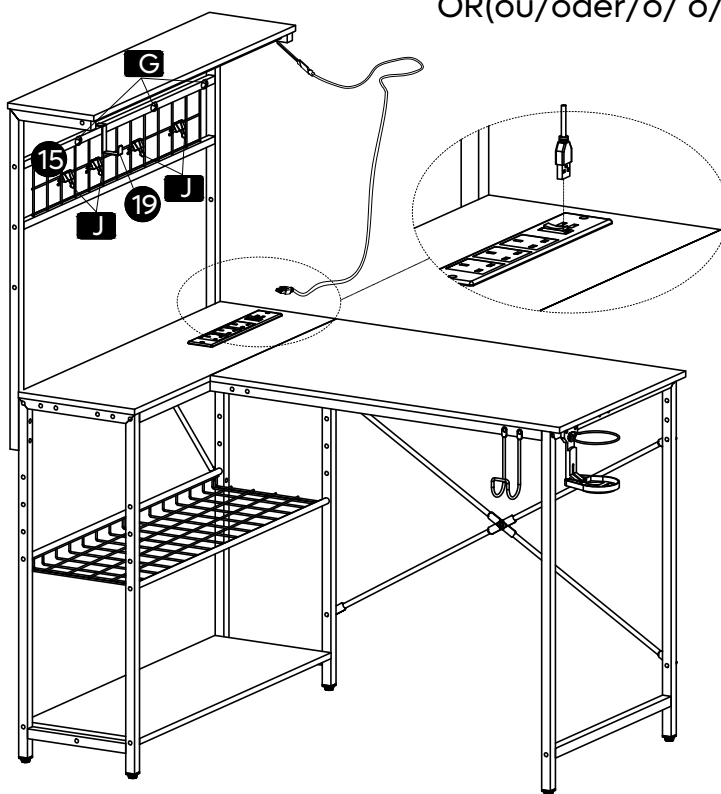

x4



x3

J

G

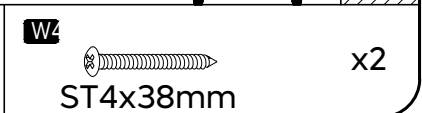
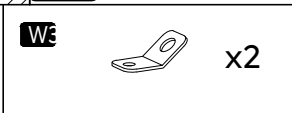
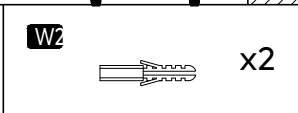
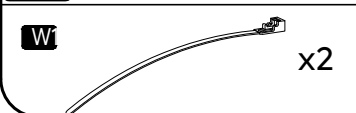
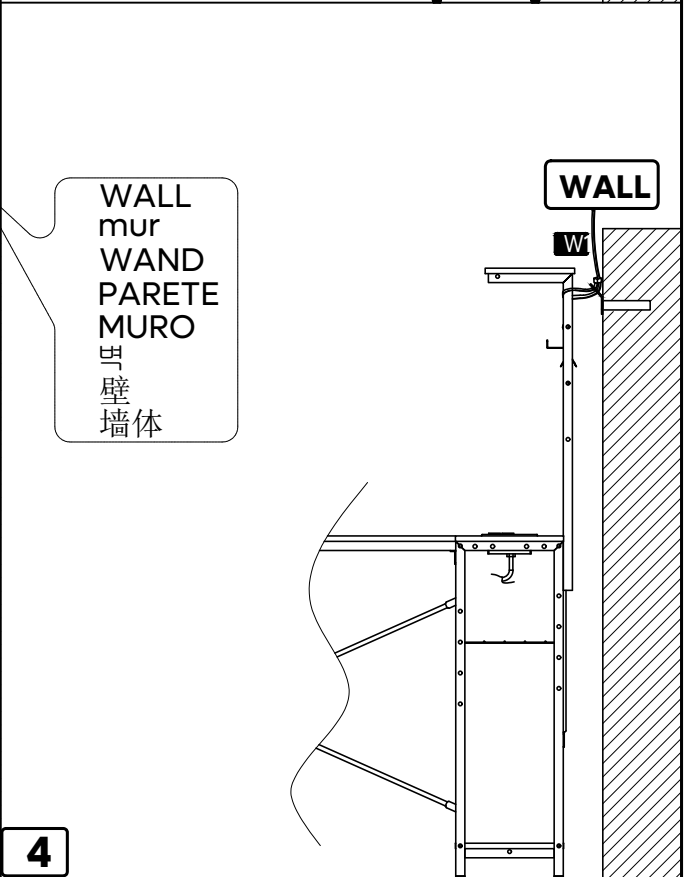
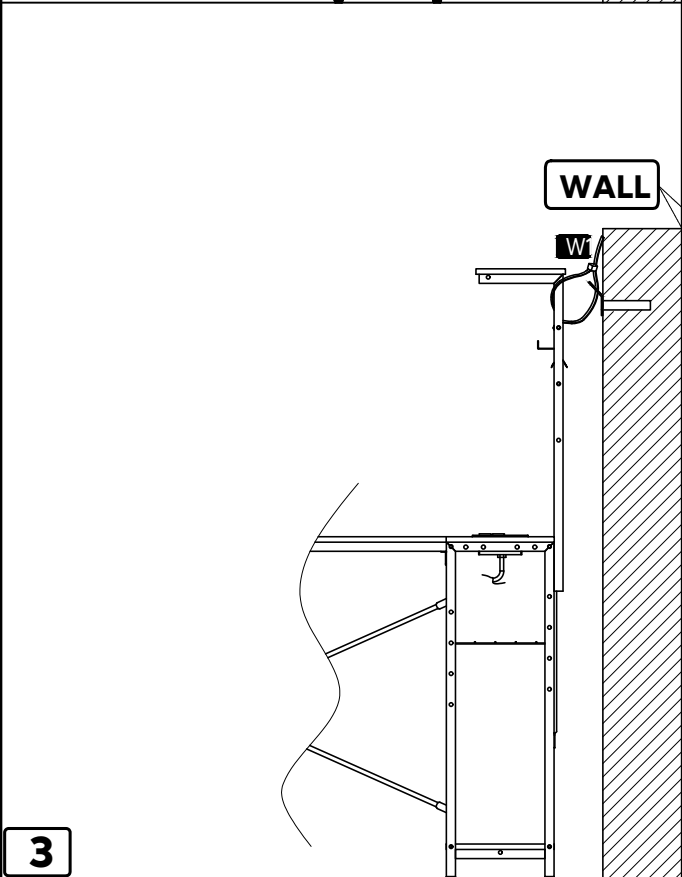
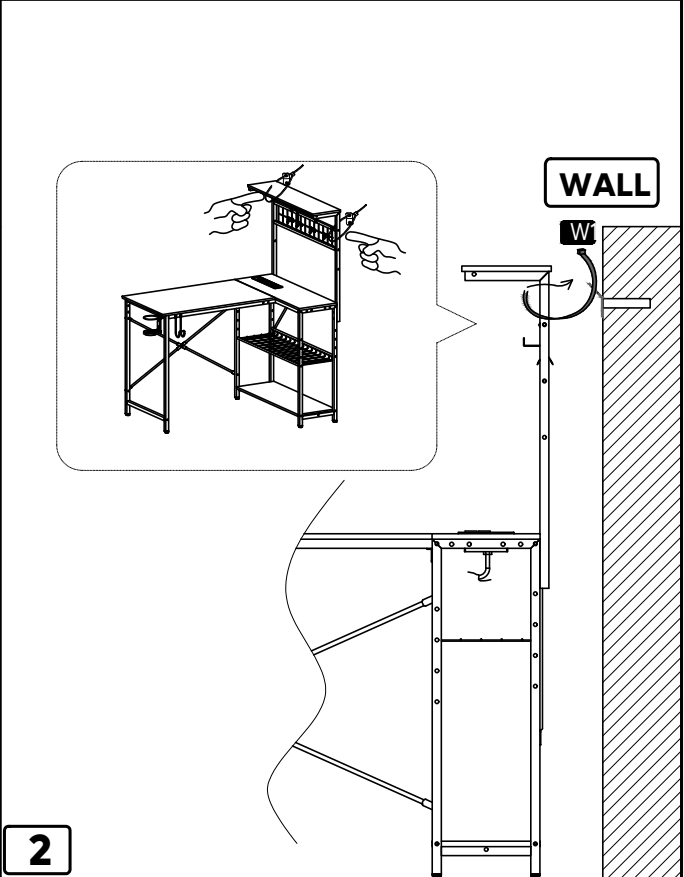
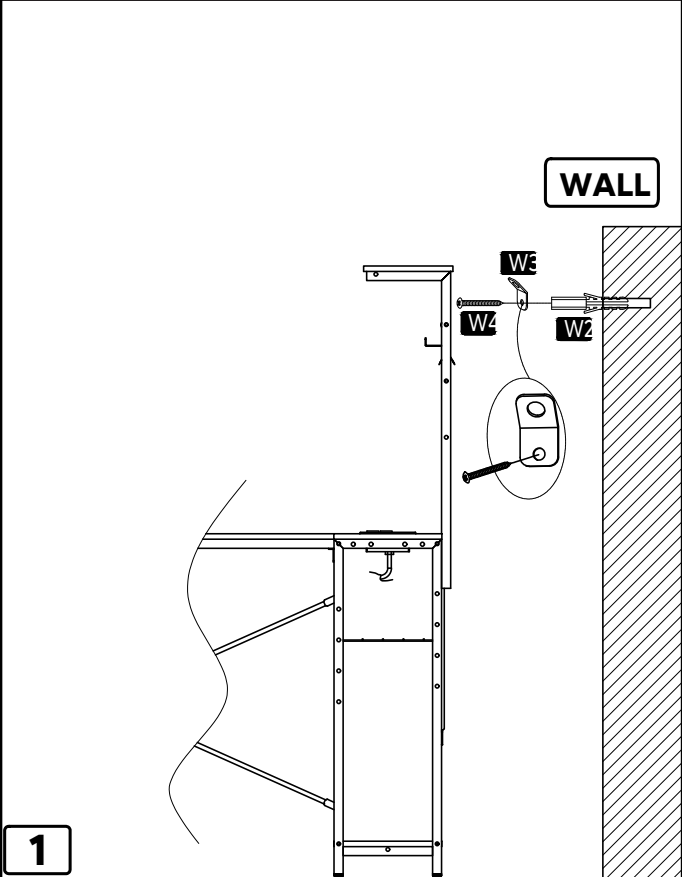

※ **Please fasten this item to wall for protection and safety.**

1. Drill 2 holes in the wall and insert "W2" into holes.  
※ You may need to use rubber mallet for tapping "W2" .
2. Use "W4" to attach "W2" with "W3" .  
※ "W4" must go through the smaller hole of "W3" and make sure the tab with larger hole is UPWARD
3. Use "W1" to connect the corresponding "W3" and tighten them as desired before locking in place.

※ **Veillez fixer ce buffet de salle à manger sur votre mur pour plus de protection et de sécurité.**

1. Percez 2 trous dans le mur et insérez "W2" dans les trous.  
※ Vous devrez peut-être utiliser un maillet en caoutchouc pour frapper "W2".
2. Utilisez "W4" pour connecter "W2" avec "W3".  
※ "W4" doit passer par le plus petit trou de "W3" et s'assurer que la languette avec le plus grand trou est VERS LE HAUT.
3. Utilisez "W1" pour connecter les "W3"s correspondant et serrez-les comme vous le souhaitez avant de verrouiller dans la place adaptée.

**Bitte befestigen Sie diesen Artikel zum Schutz und zur Sicherheit an der Wand.**

1. Bohren Sie 2 Löcher in die Wand und setzen Sie die "W2" in die Löcher ein.  
Möglicherweise müssen Sie einen Gummihammer zum Klopfen von "W2" verwenden.
2. Verwenden Sie "W4", um "W2" mit "W3" zu verbinden.  
"W4" muss durch das kleinere Loch des "W3"s gehen und sicherstellen, dass die Lasche mit dem größeren Loch nach OBEN zeigt.
3. Verwenden Sie "W1", um die entsprechenden "W3"s zu verbinden, und ziehen Sie sie wie gewünscht fest, bevor Sie sie verriegeln.

**Si prega di fissare questo articolo alla parete per protezione e sicurezza.**

1. Praticare 2 fori nella parete e inserire "W2" nei fori.  
Potrebbe essere necessario usare un martello di gomma per fissare il pezzo "W2".
2. Utilizzare "W4" per collegare "W2" con "W3".  
"W4" deve passare attraverso il foro più piccolo di "W3", facendo in modo che la linguetta con il foro più grande sia VERSO L'ALTO.
3. Utilizzare "W1" per collegare i "W3" corrispondenti e stringerli a proprio piacimento prima di bloccarli in posizione.

※ 보호와 안전을 위해 이 물건을 벽에 고정하십시오.

1. 벽에 구멍 2 개를 뚫고 W2 를 구멍에 삽입합니다.

※ 고무망치로 W2 를 두드려야 할 수도 있습니다.

2. "W4" 를 사용하여 W2 를 W3 에 연결합니다.

※ W4은 W3의 작은 구멍을 통과하고 큰 구멍의 볼록 귀가 위로 향하도록 해야 합니다.

3. W1를 사용하여 적절한 W3를 연결하고 필요에 따라 조여 잠급니다.

---

### **Fije este elemento a la pared como medida de protección y seguridad.**

1. Taladre 2 orificios en la pared e inserte el tornillo "W2" en los orificios.

Es posible que tenga que utilizar el mazo de goma para golpear "W2".

2. Utilice "W4" para unir "W2" con "W3".

"W4" debe atravesar el pequeño orificio de "W3". Asegúrese de que la aleta con el orificio mayor esté orientada HACIA ARRIBA.

3. Utilice "W1" para conectar los "W3" correspondientes, y apriételes según sus preferencias antes de inmovilizarlos en su posición.

---

### **安全のために、オープンシェルフを壁に固定してください。**

1. 壁に2つ穴を開け、"W2"を穴に差し込む。

"W2"を叩くにはラバーハンマーが必要かもしれません。

2. "W4"を使用し、"W2"と"W3"を接続してください。

"W4"は"W3"の小さな穴を通り抜け、大きい穴のラベルが上を向いていることを確認する必要があります。

3. "W1"を使用して二つの"W3"を接続し、所定の位置にロックする前に必要に応じて締め付ける。

---

### **请将此产品固定在墙上以防护和安全。**

1. 在墙上钻 2 个孔，然后将 "W2" 插入孔中。

您可能需要使用橡皮槌敲击 "W2"。

2. 用 "W4" 将 "W2" 与 "W3" 连接。

"W4" 必须穿过 "W3" 的小孔，并确保有较大孔的朝向向上

3. 用 "W1" 连接对应的 "W3" 大孔，并按需要拉紧，然后锁定到位。

# Socket Instructions

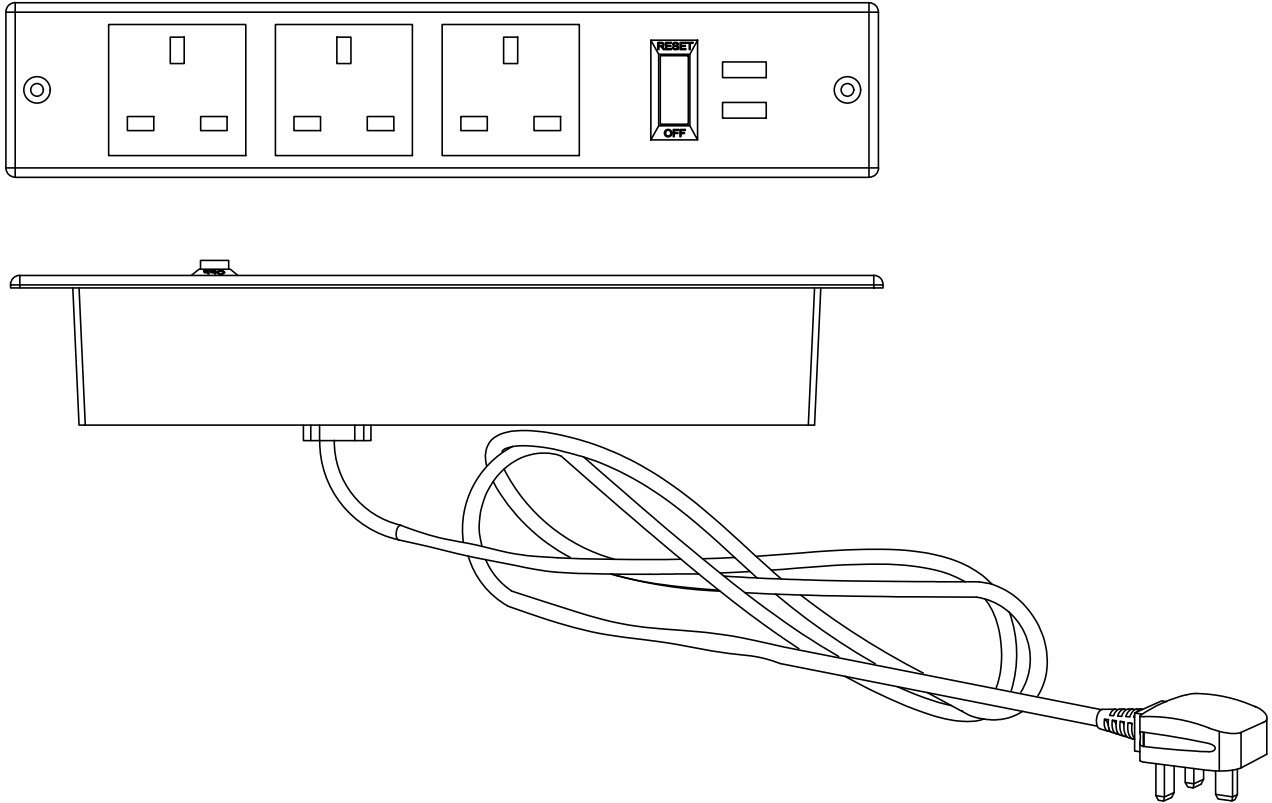

## Product Description:

The product is designed with embedded panel and is fixed on the table with the screw holes at both ends. 3 grounded AC power sockets and 2 USB ports are provided, to supply power to 5 devices at the same time. The wire of the socket is 6.56 feet long, and durable and environmentally friendly PVC insulation and sheath are adopted for the wire. The integrated circuit breaker with reset switch is specially designed to cut off the current flowing to your equipment when the maximum amperage threshold is exceeded, to prevent your equipment from overheat and on fire. The product has passed UKCA certification and has been supported by industry safety standards.

## Socket Instructions

### Product Specification (overall):

28CM (11inch) x 4.7CM (1.85inch) x 5.5CM (2.17 inch)

- ① Weight: 0.4KG
- ② Cable/length: 2.0M (6.56 ft)
- ③ USB Output: 5V=2.1A
- ④ Peak power: 2400W
- ⑤ Industry certification: UKCA
- ⑥ AMP grade: 10A
- ⑦ Number of sockets: 3
- ⑧ Made in China

### Reminder:

1. Please keep the socket away from the children;
2. Please cut off the powersupply when it is not used for a long time;
3. Please cut off the power when cleaning the table, and keep wet rags or water away from the socket area;
4. Do not place the cup or drink near the socket to avoid splashing water into the socket and causing accidents.