

Name • Nom • Nome • Naam • Nazwa • Иméно
• Názov • Néв • Denumire • Isim • Извание

Typ • Type • Tip • Típus • Tipo Tun

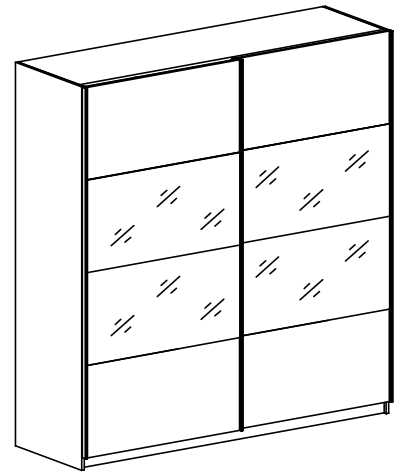
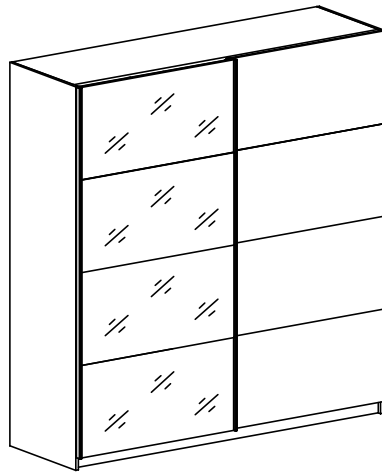
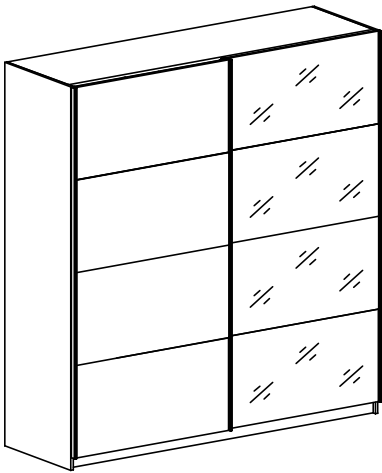

- (D) Montageanleitung**
- (NL) Handleiding voor de montage**
- (TR) Montaj talimatı**
- (F) Notice de montage**
- (CZ) Montážní návod**
- (HU) Szerelési útmutató**

- (GB) Assembly instructions**
- (PL) Instrukcja montażu**
- (RU) Инструкция по монтажу**
- (IT) Istruzioni di montaggio**
- (SK) Návod na montáž**
- (RO) Instrucțiuni de montaj**

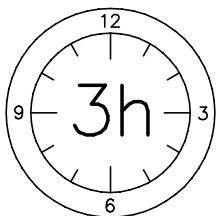
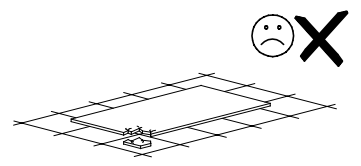
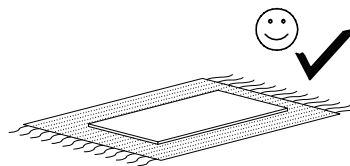
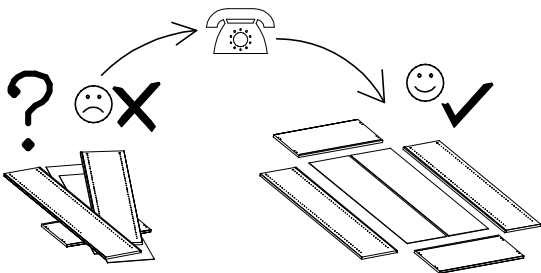
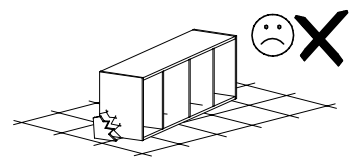
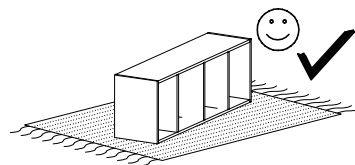
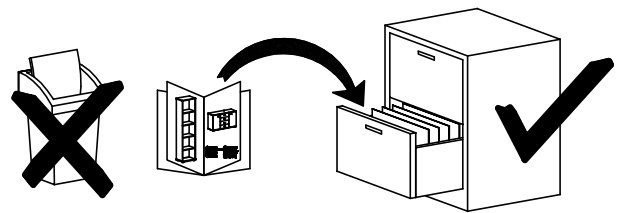
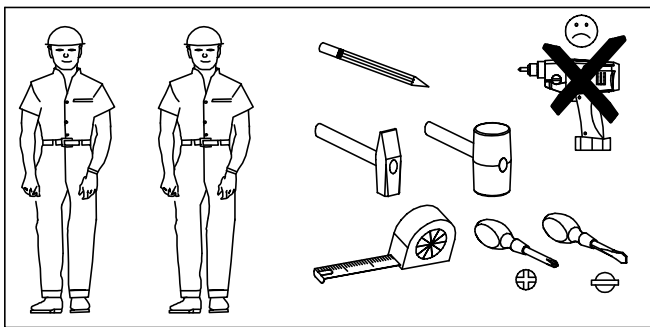

ASSEMBLE DIFFICULTY:
1 2 3 **4** 5

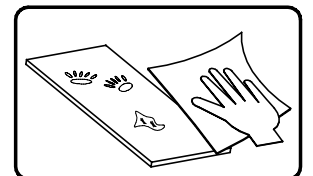
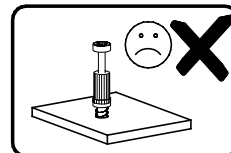
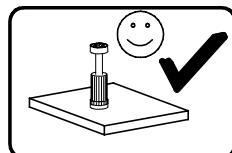

Name • Nom • Nome • Naam • Nazwa • Jméno
• Názov • Név • Denumire • Isim • Название

Typ • Type • Tip • Típus • Tipo Tun

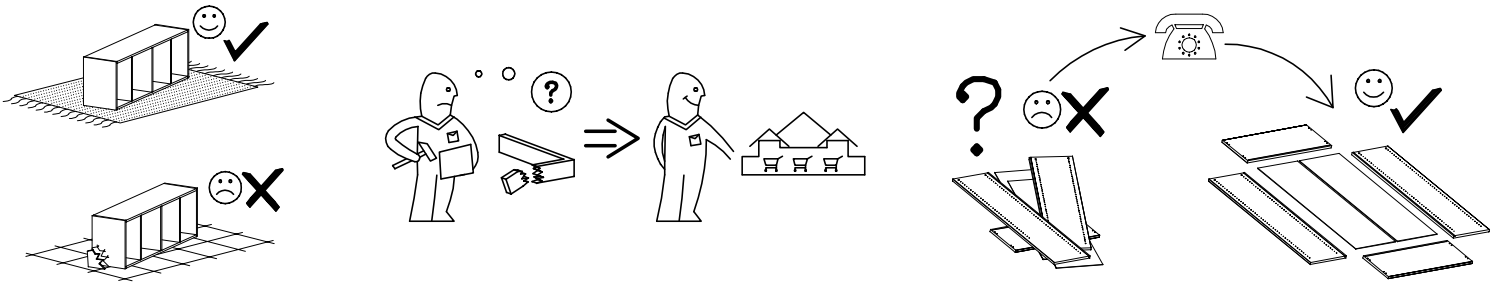

Onderhoud – Entretien – Maintenance

L'information générale: Ne mettez jamais des objets chauds sur la surface des meubles. Veuillez utiliser des sous verres.

Entretien: utilisez un chiffon légèrement humide et séchez aussitôt. Toute trace de liquide doit être enlevé immédiatement. Les meubles ne sont pas adaptés aux pièces humides. N'utilisez jamais des éponges abrasives, amoniac, solvant, détergent, diluant, produits chimiques ou cirage ou des produits d'entretien comme Pledge etc...

Notice de montage fconserver.

Service après-vente: Pour tout service après-vente, rendez-vous au magasin où vous avez acheter vos meubles avec cette notice.

Garantie: Nous vous informons qu'en cas de non respect aux prescriptions susmentionnés que la garantie expire immédiatement.

General information: Do never put hot items on the table tops!

Maintenance: Clean with slightly wet moistened cloth, wipe dry immediatly. Wipe off wetness at once. Not suited for humid locations. Never use Solvent, cleaner, thinner, chemical products or wax. Retain manual instruction.

For the after sales: For the after sales, go back to the shop with this assembly instructions.

Guarantee: Attention in case of non respect to the above prescriptions the warranty expires immediatly.











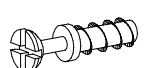

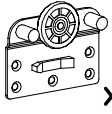
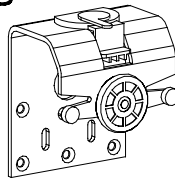
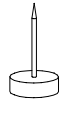
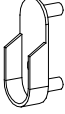

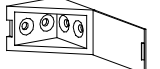

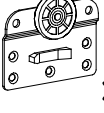
Algemene Informatie: Voor tafels geldt geen hete pannen, thee glazen en waxinelichtjes op de ondergrond plaatsen. Gebruik hiervoor altijd een onderzetter.

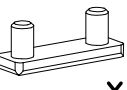
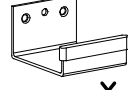
Onderhoud: Met licht vochtige doek reinigen hierna direct droog wrijven. Vocht op het bovenblad direct opnemen. De meubels zijn niet voor vochtige ruimten bestemd. Gebruik nooit een schuurpons, shuurmiddel, amoniak, oplosmiddel, reinigingsmiddel, verdunner, chemische producten, boenwas of producten als Pledge was of dergelijke. Montage tekening opbergen.

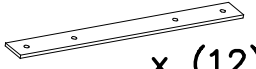
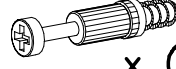
Service na verkoop: Voor Service na verkoop, ga naar uw leverancier met deze montage handleiding.

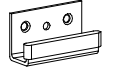
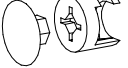
Garantie: Het niet naleven van deze onderhoudsvorschriften doet de garantie met onmiddellijke ingang verloren gaan.

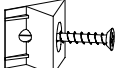

| | | | | | |
|--|--|--|--|--|--|
| | | | | G1  4x13 x...(48) | K12  x...(40) |
| K11  x...(40) | T29  x...(1) | T28  x...(2) | P4  x...(6) | S18  x...(4) | |
| T19  2088mm x...(2) | T12  1906mm x...(1) | | F8  x...(10) | G36  3,5x13 x...(107) | |
| T30  x...(1) | T11  1906mm x...(1) | P3  x...(4) | T31  x...(2) | T15  x...(2) | |
| M9  x...(12) | K5  x...(20) | T17  2088mm x...(1) | S5  571mm x...(2) | T32  x...(2) | |
| K1  ø15x12 x...(20) | B1  ø8x35 x...(30) | I1  x...(32) | T18  2088mm x...(3) | G12  4x25 x...(4) | |



Service • Assistenza • Dienstverlening • Serwis • Servis • Szerviz • Сервисная служба

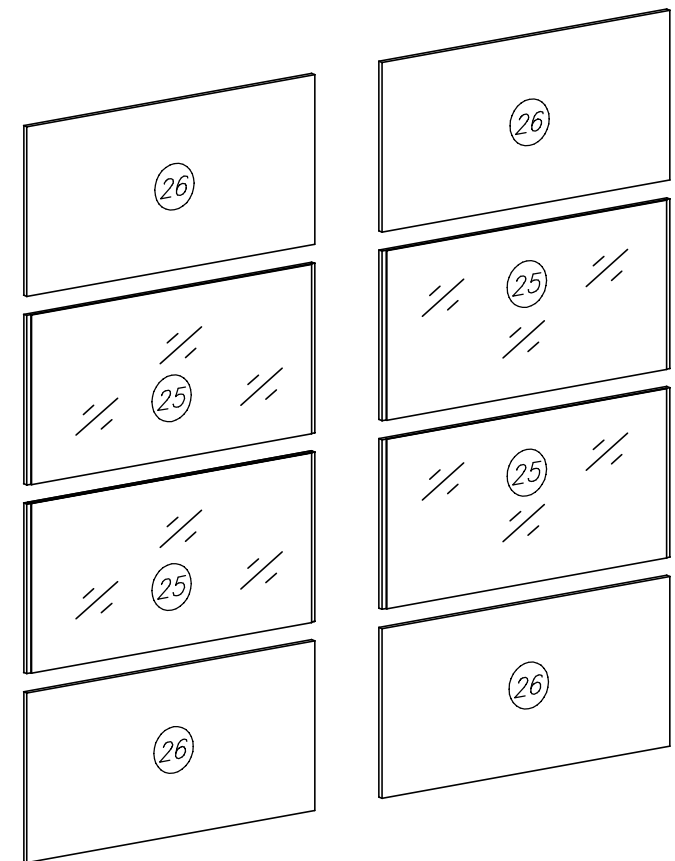
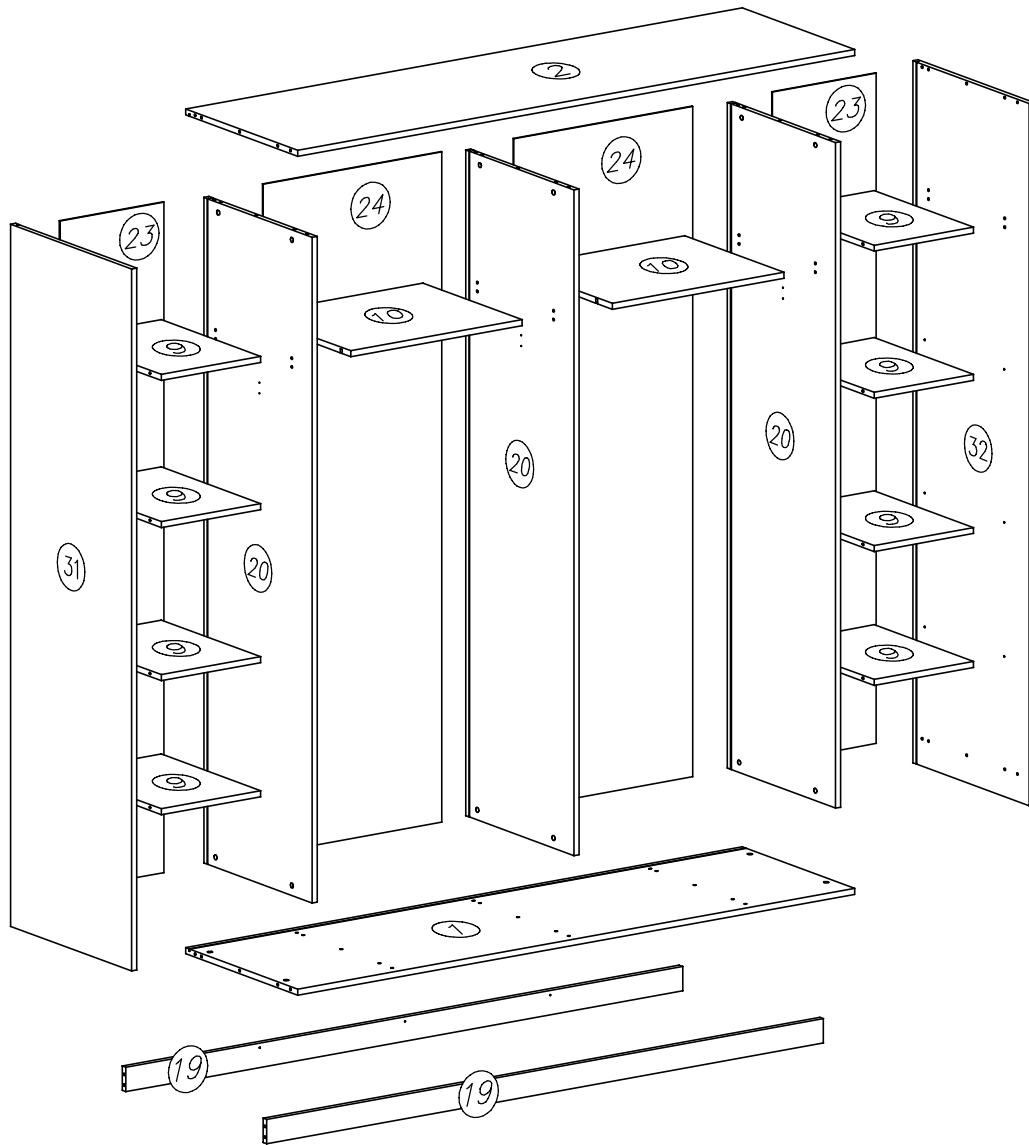



1

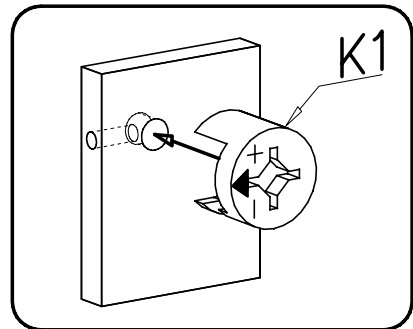
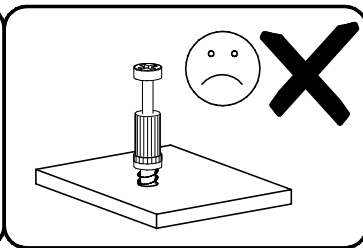
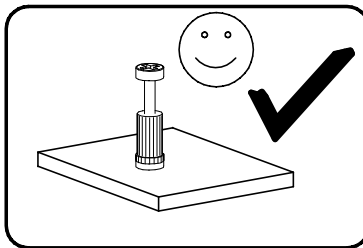
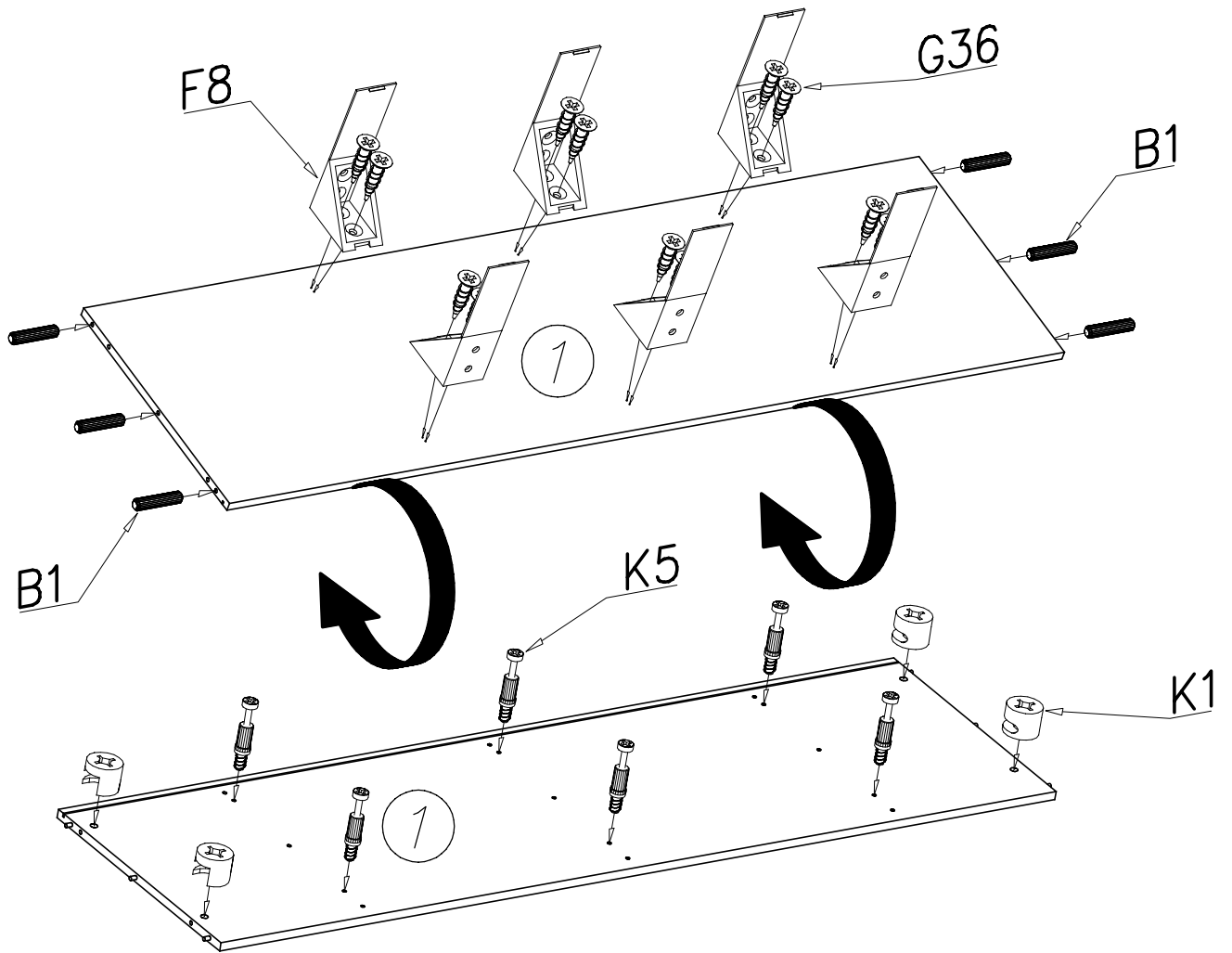

2

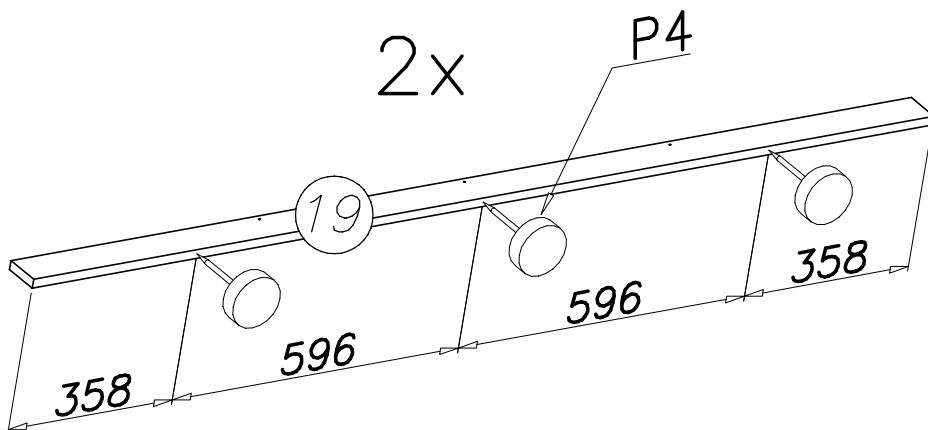



3

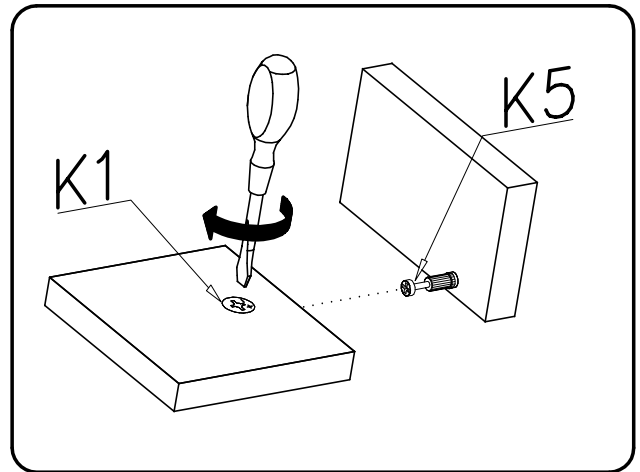
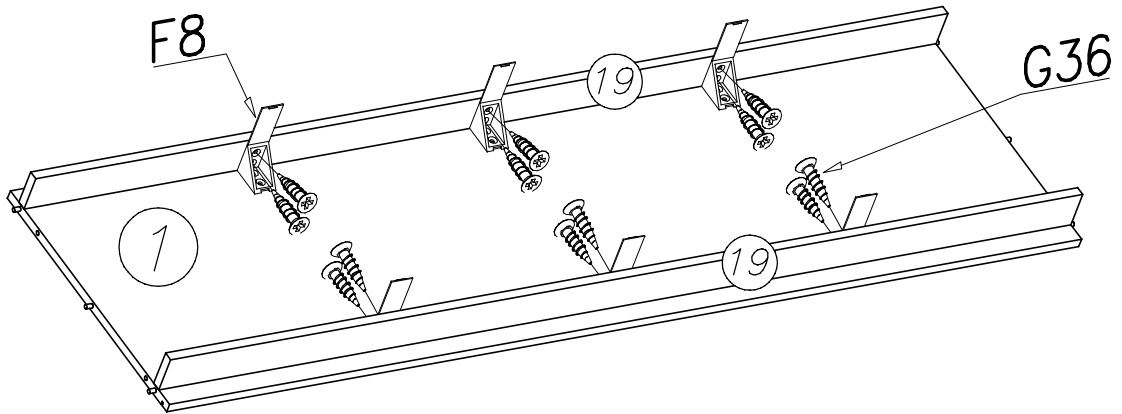

4

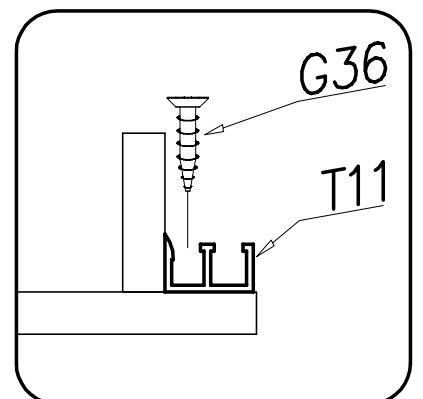
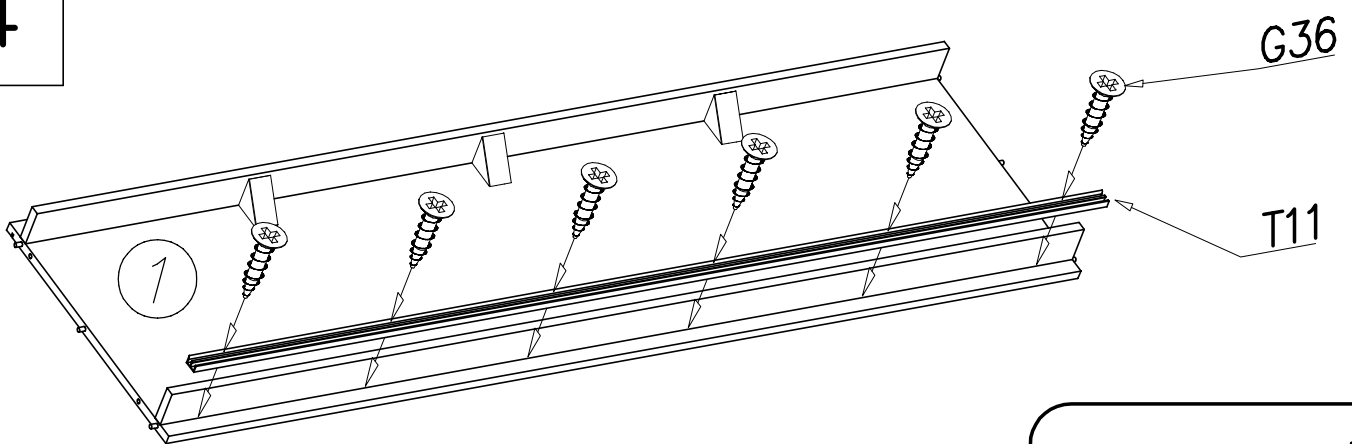



5

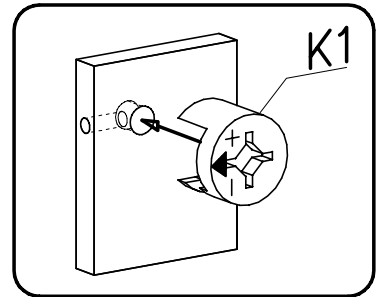
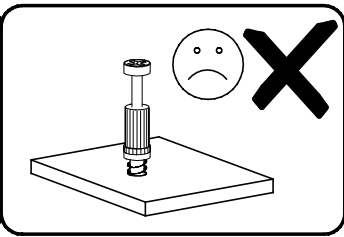
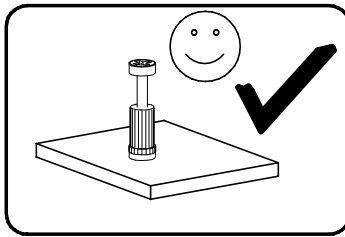
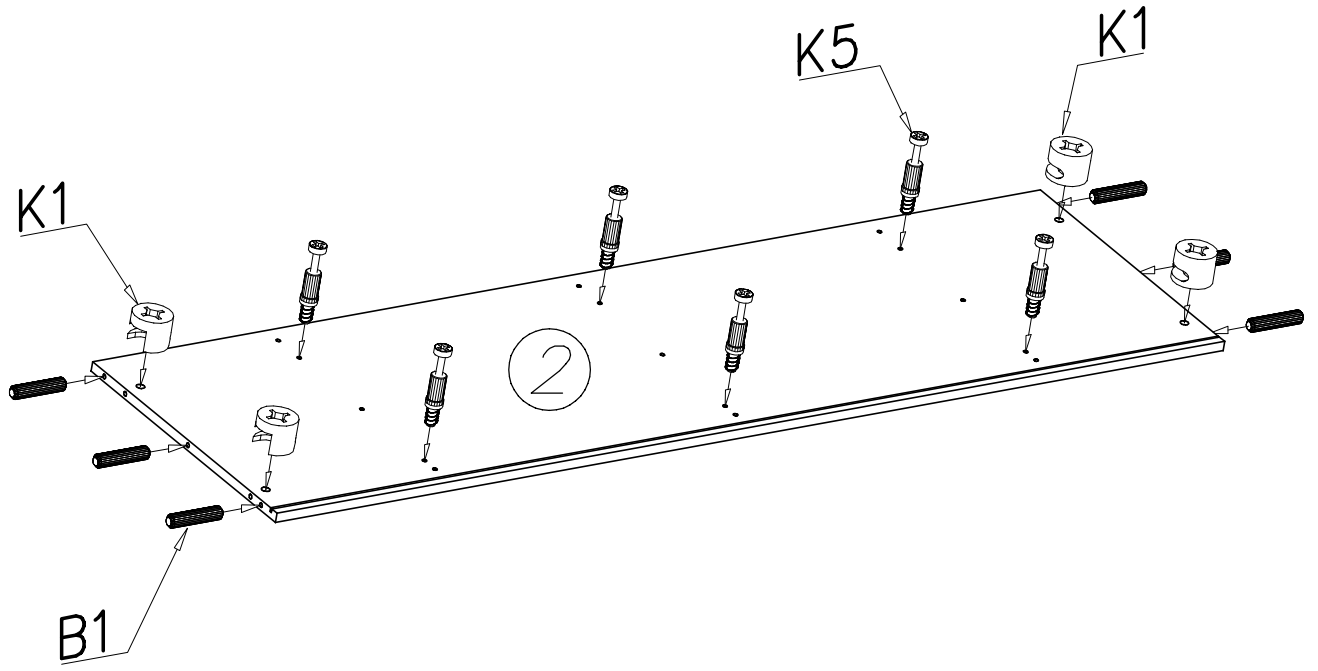

6

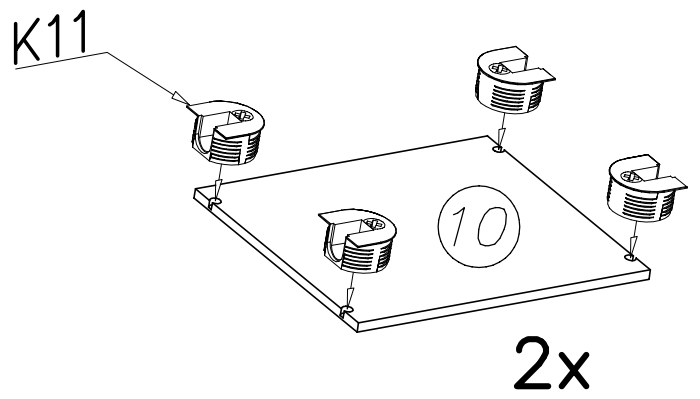
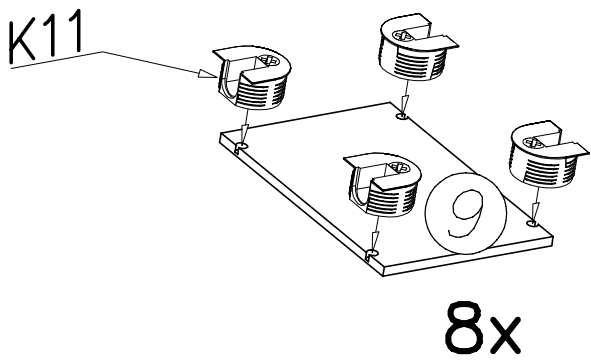



7

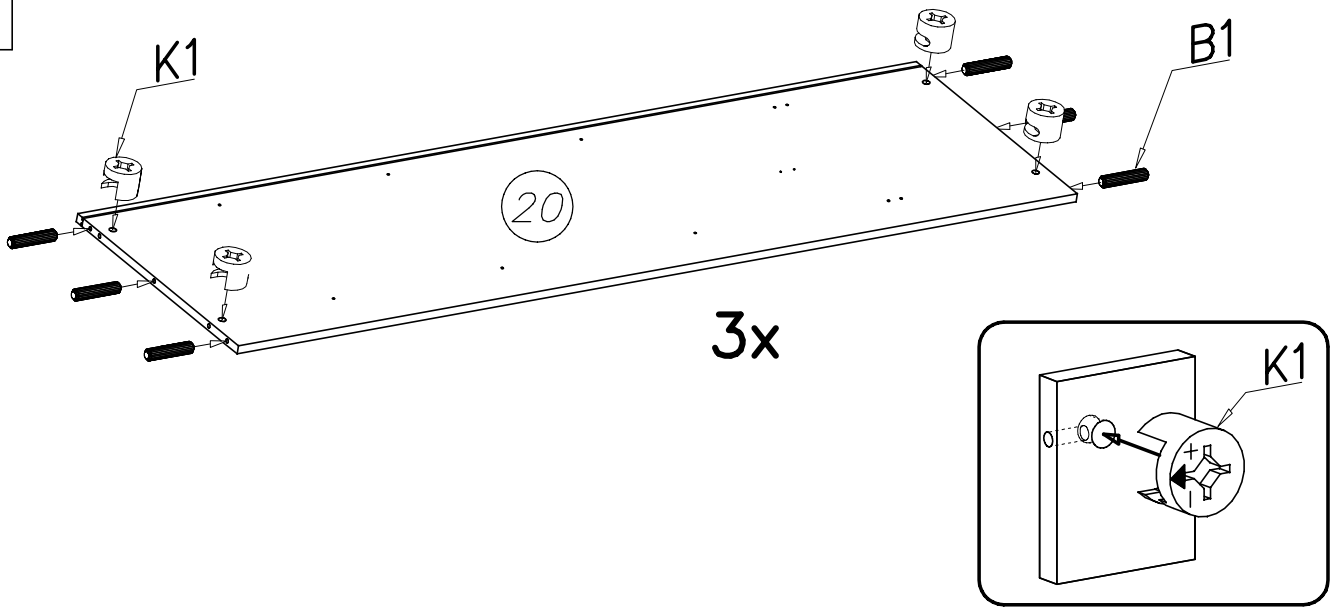

8

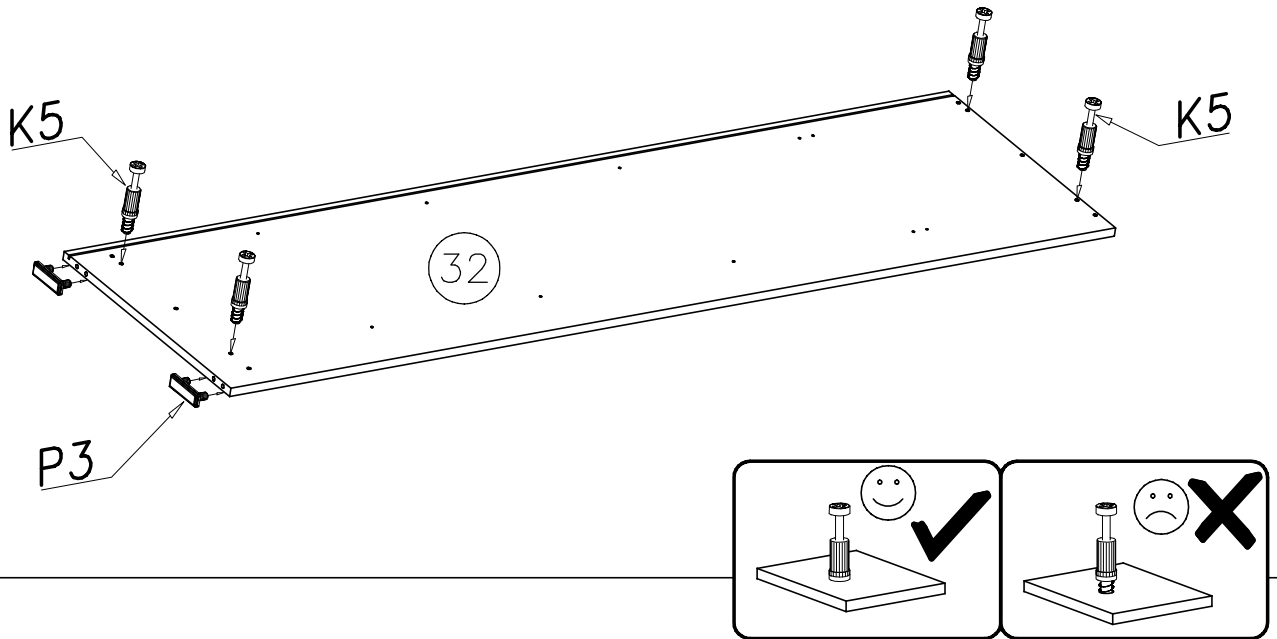

9

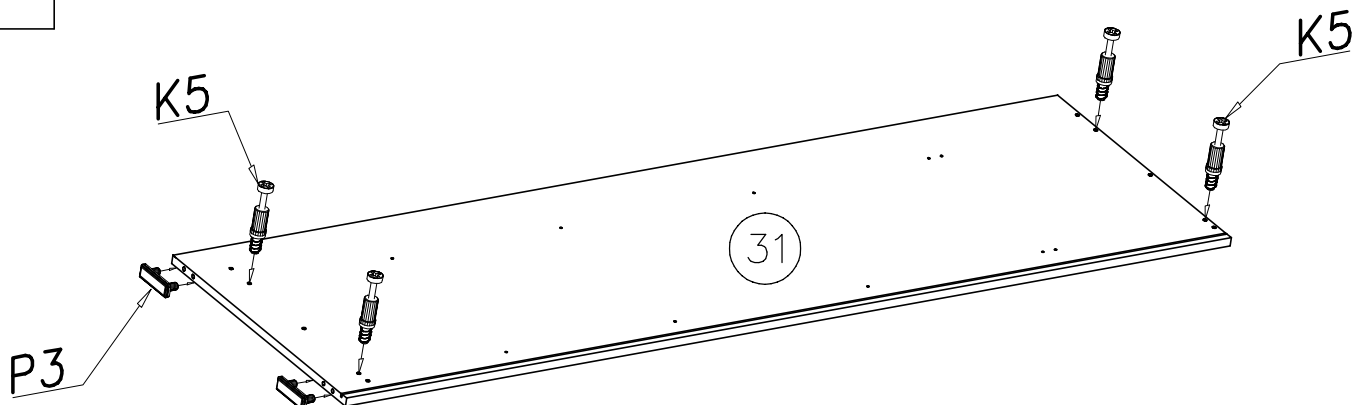



10

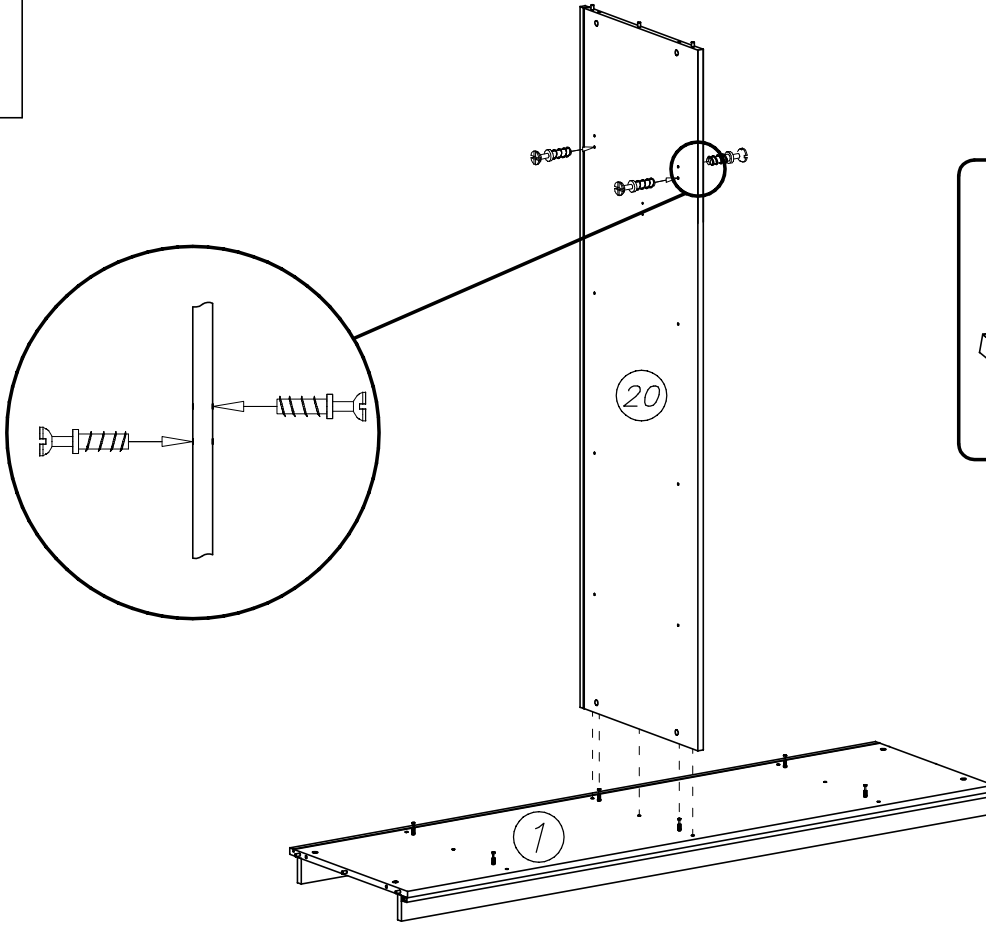

11

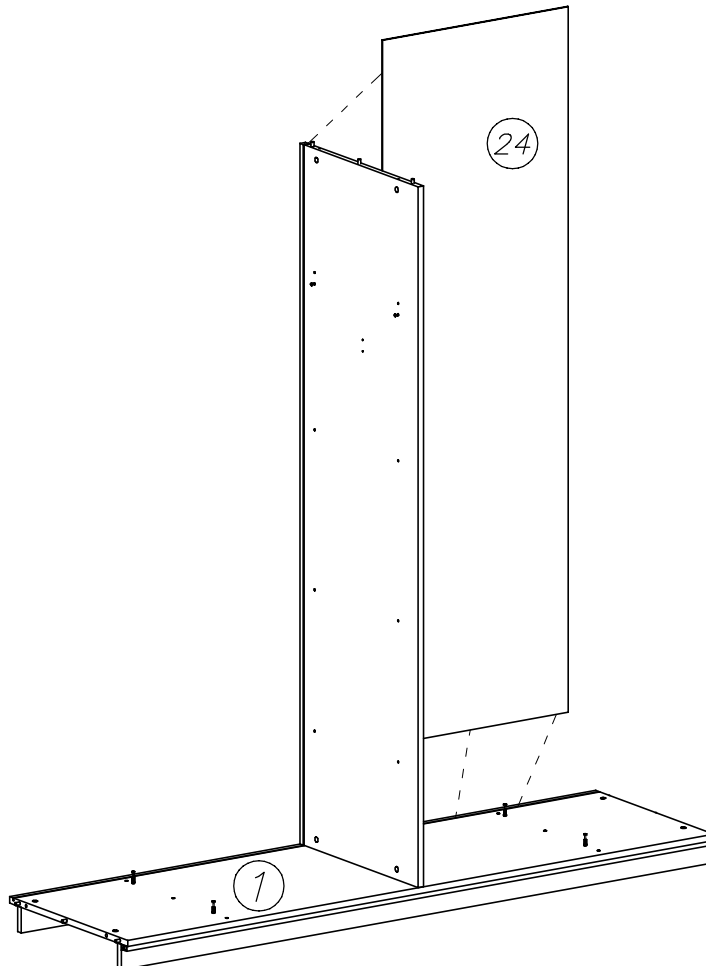



12

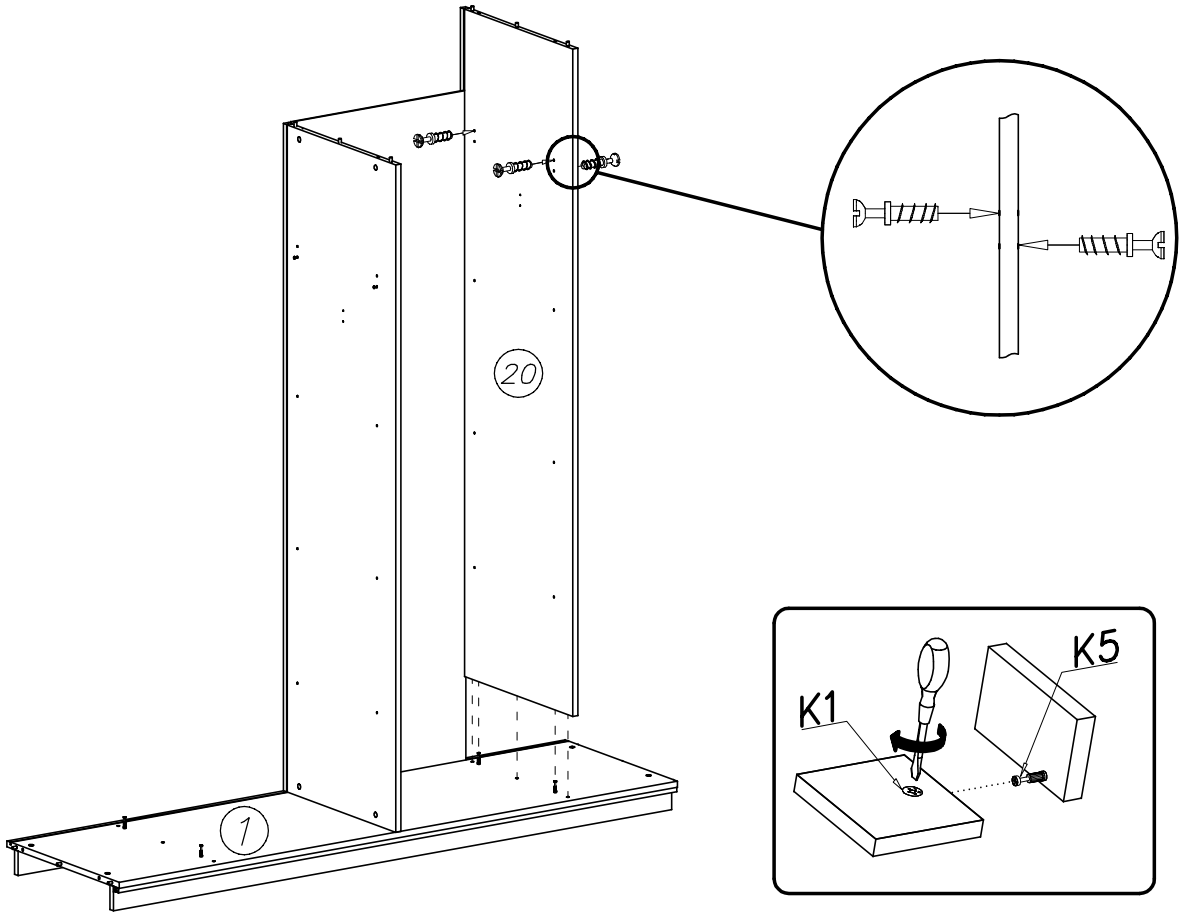

13

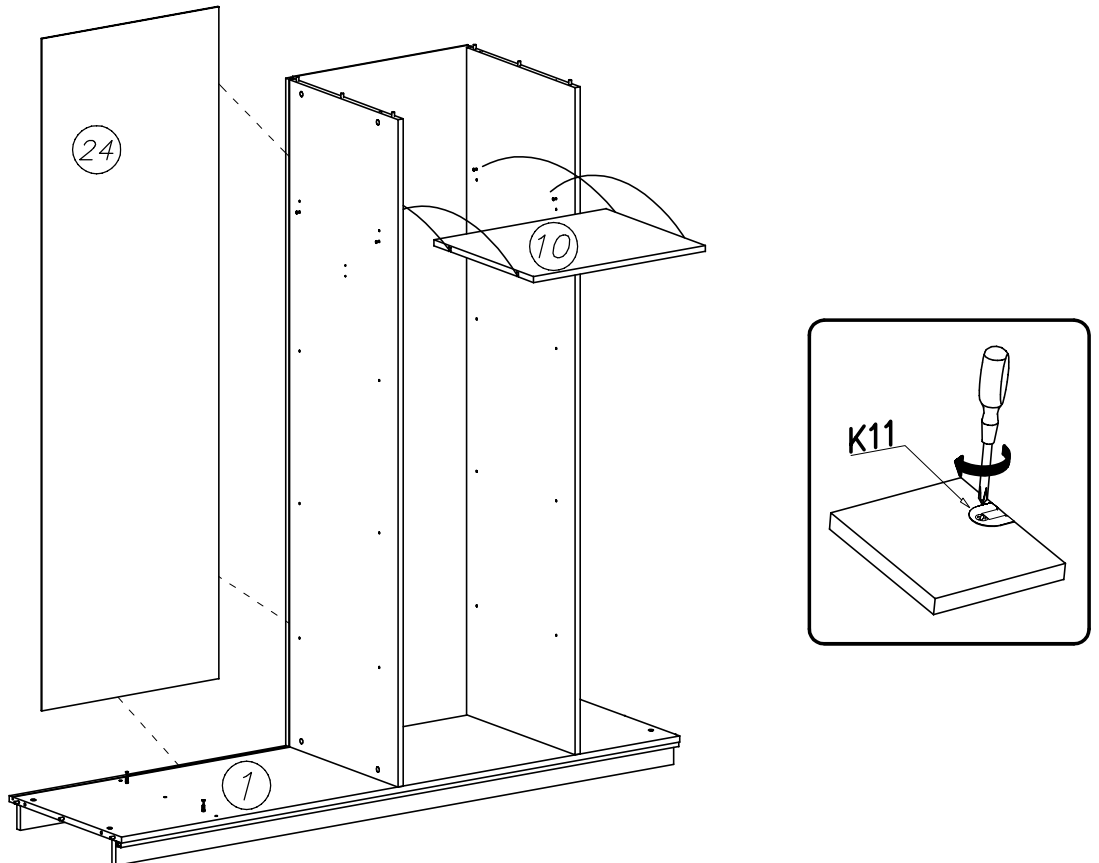

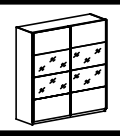

14

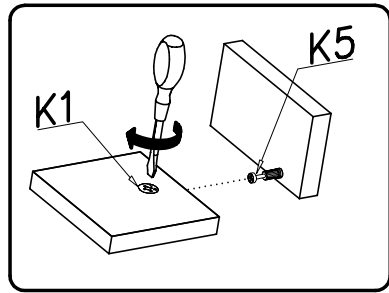
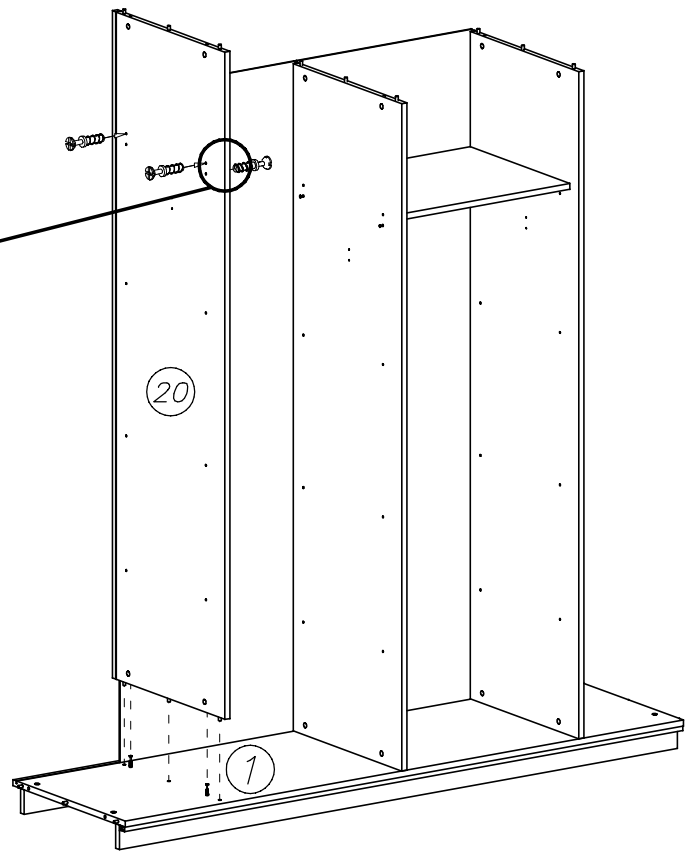
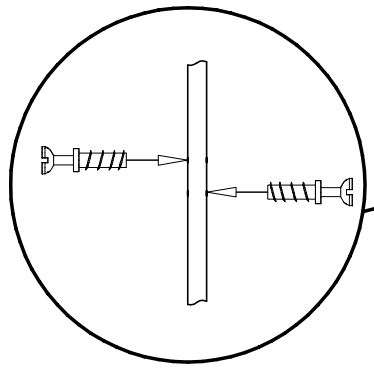

15

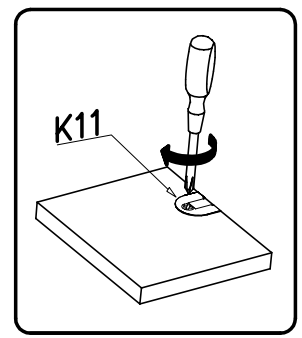
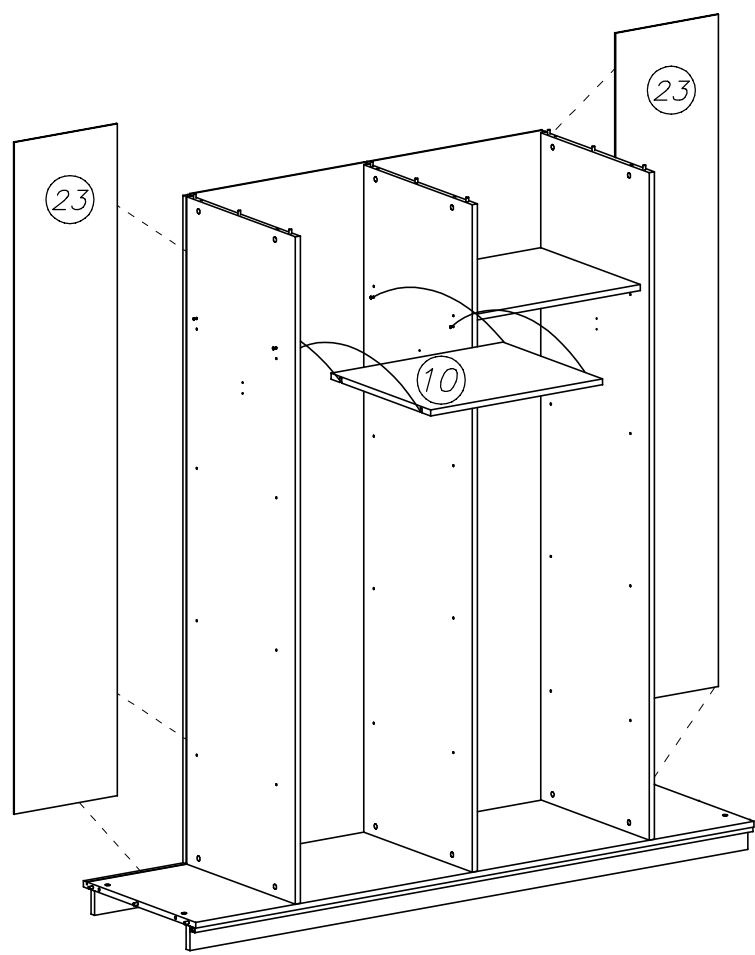



16

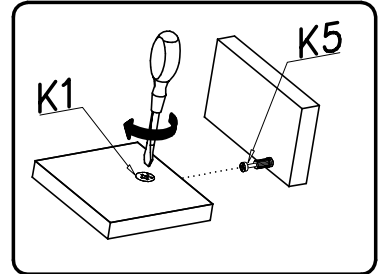
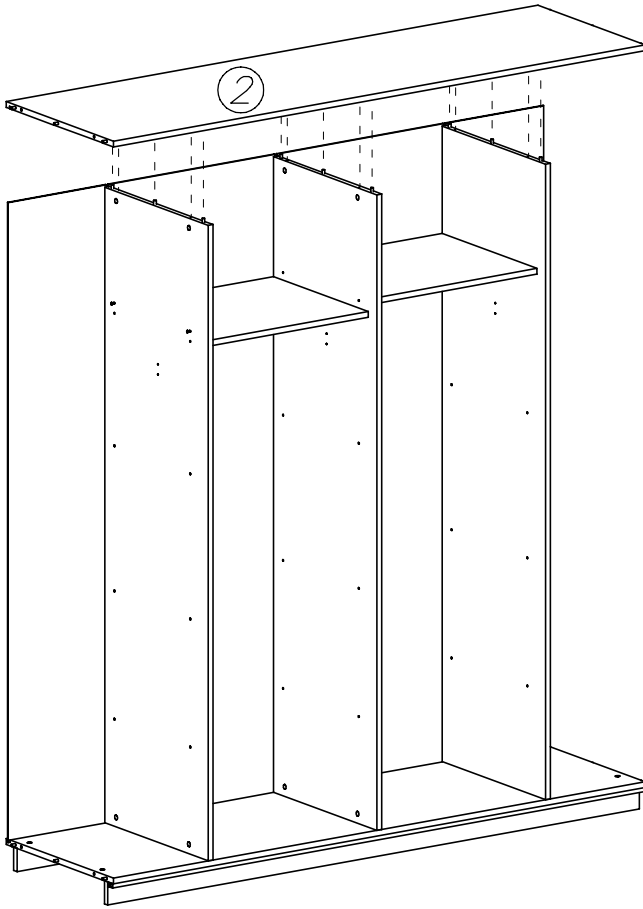

17

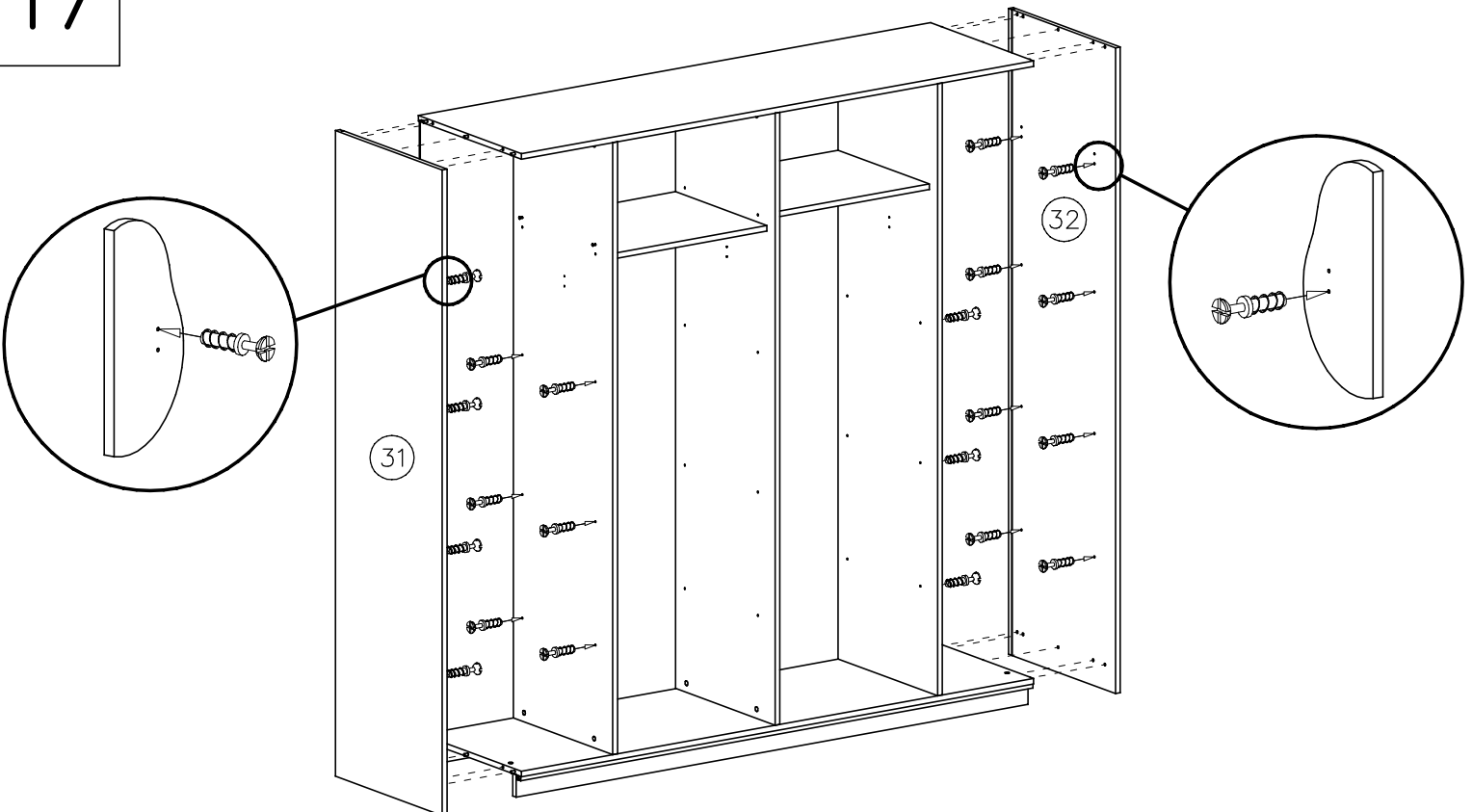



18

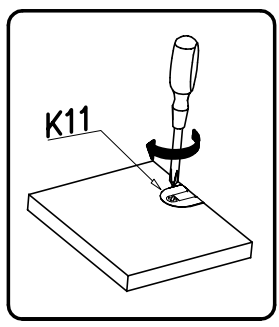
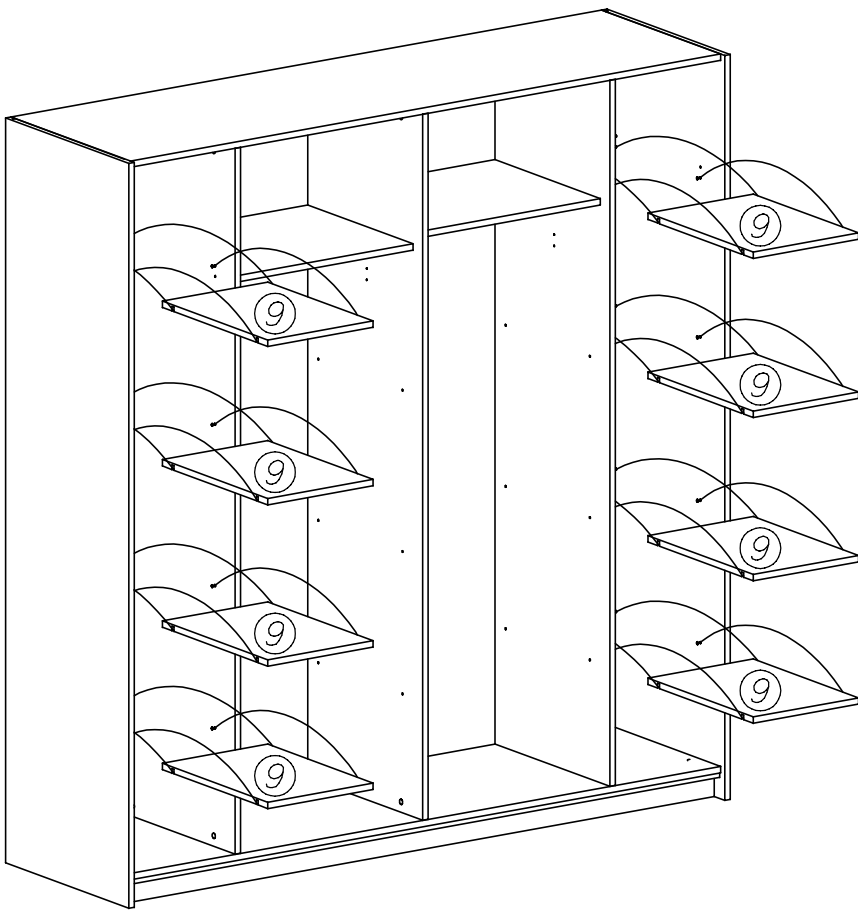

19

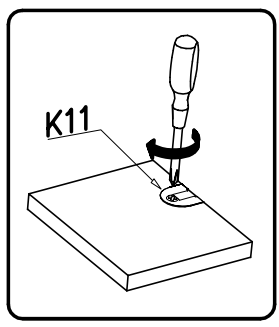
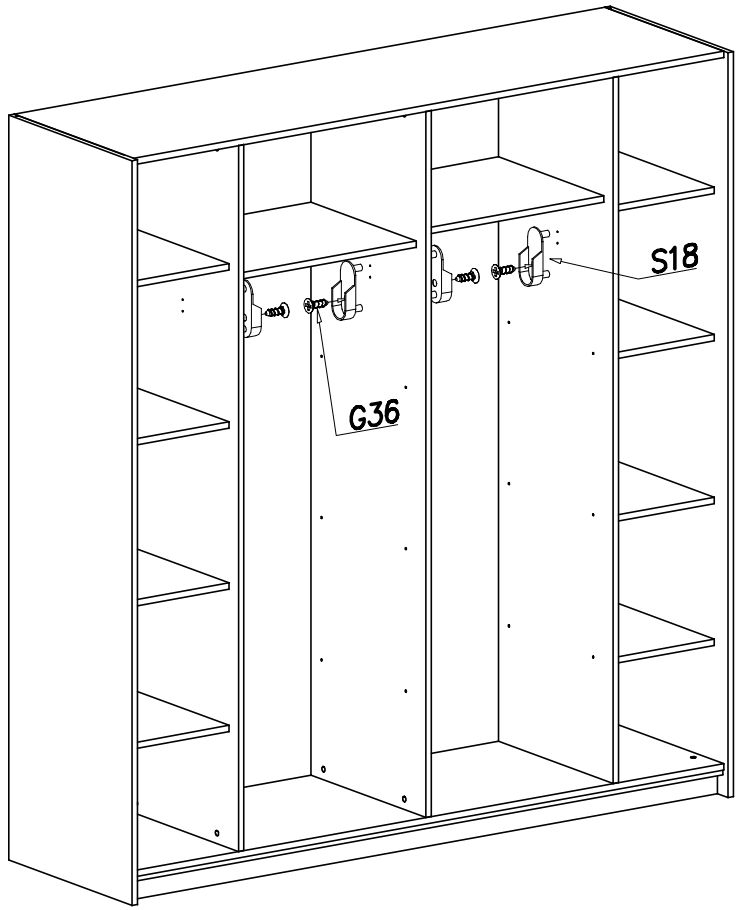

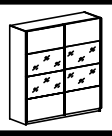

20

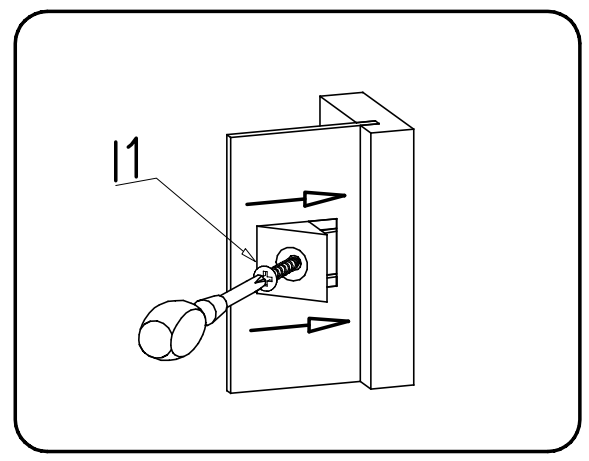
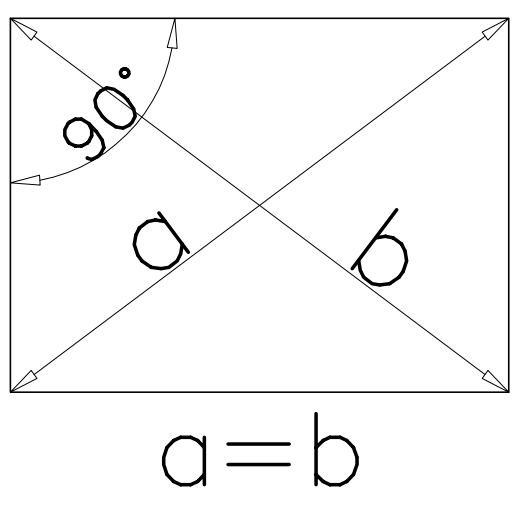
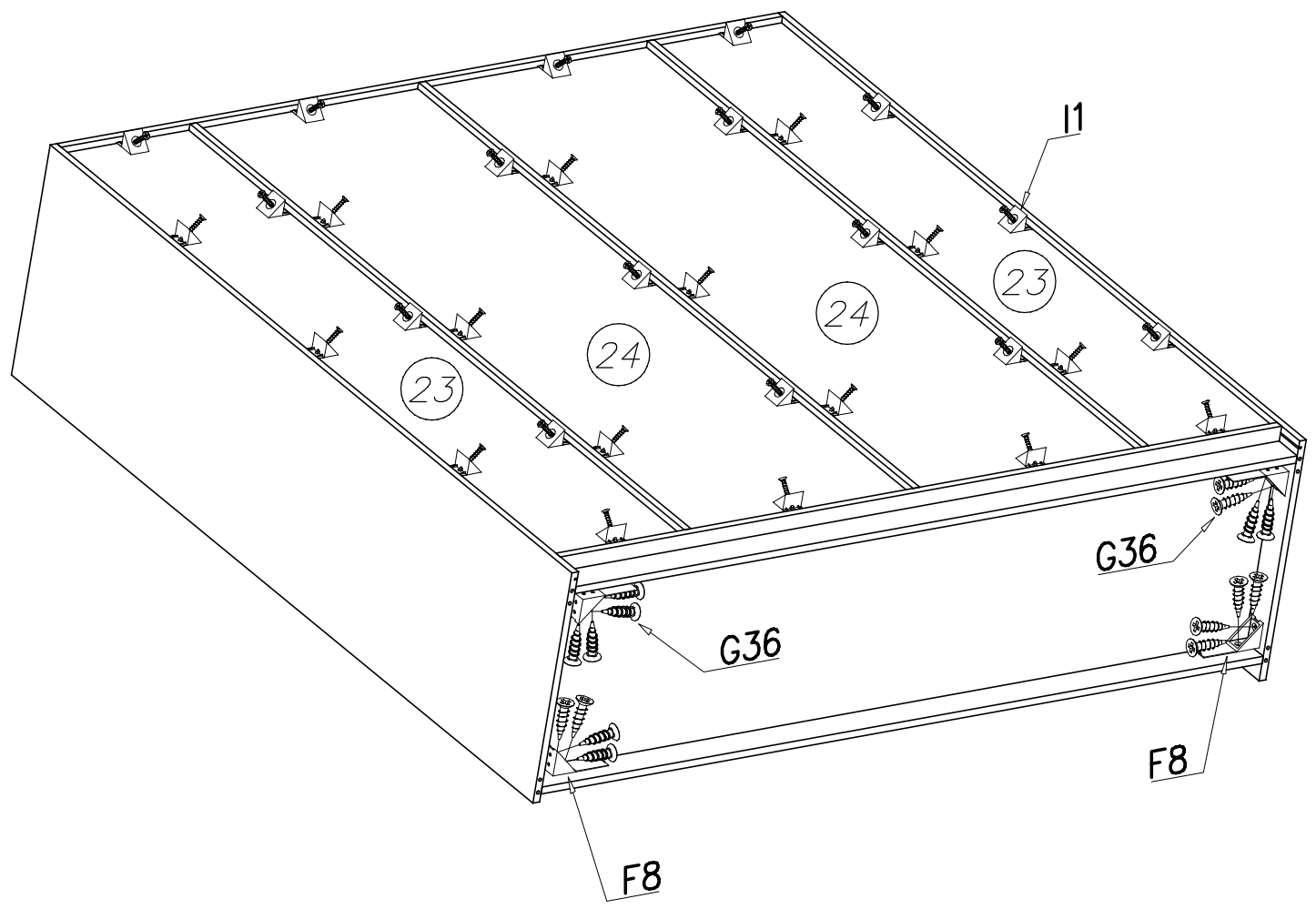

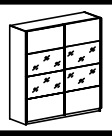

21

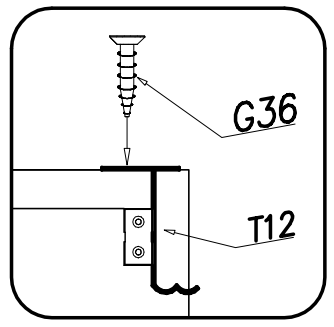
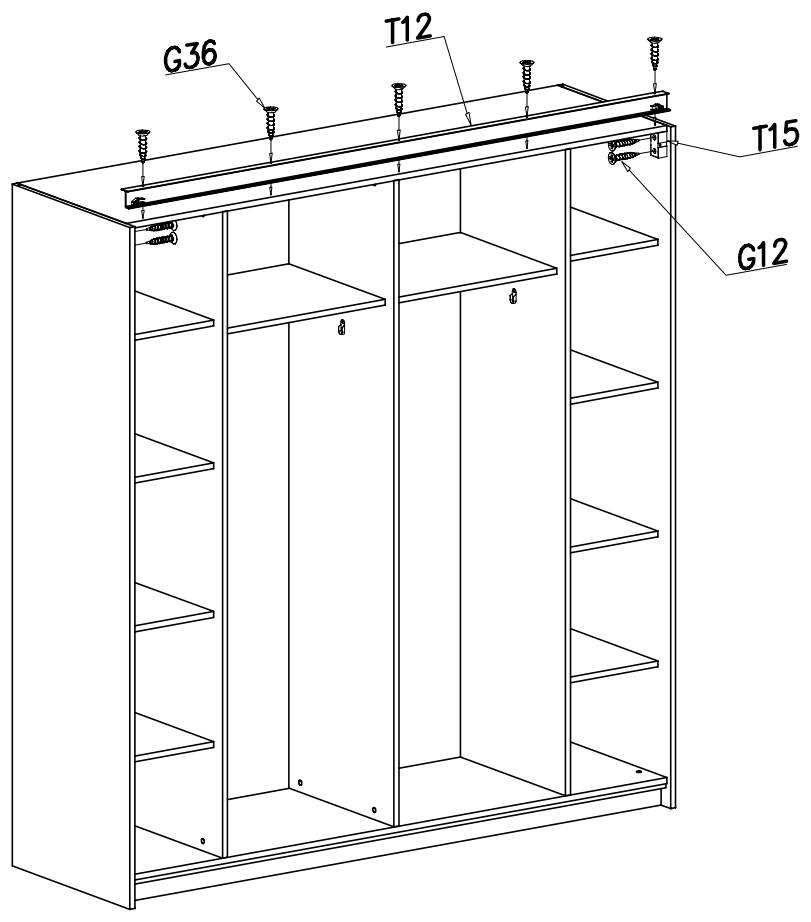

22

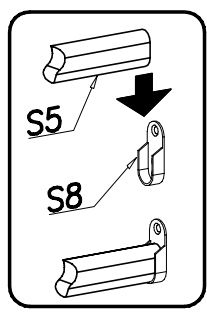
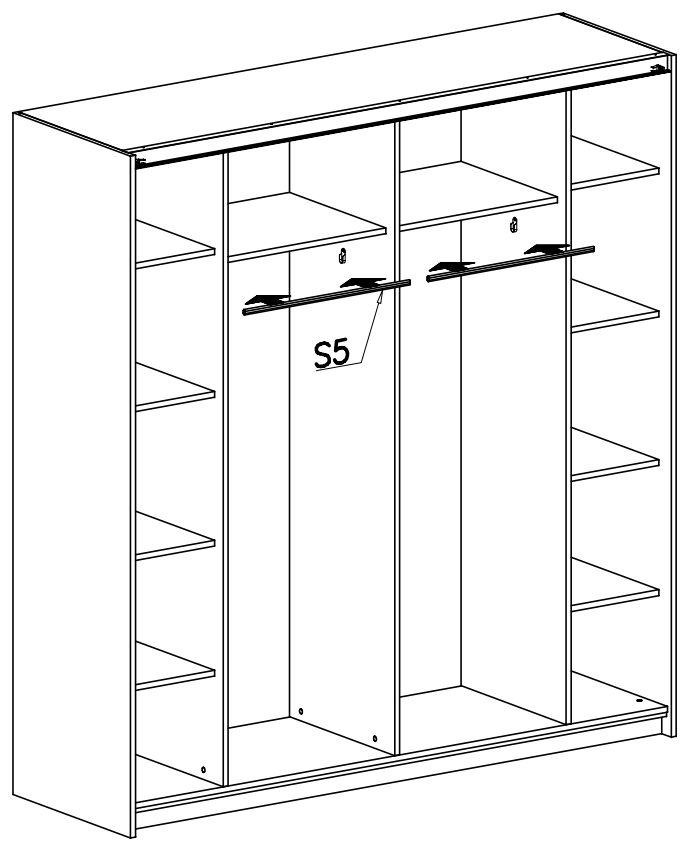

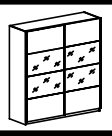

23

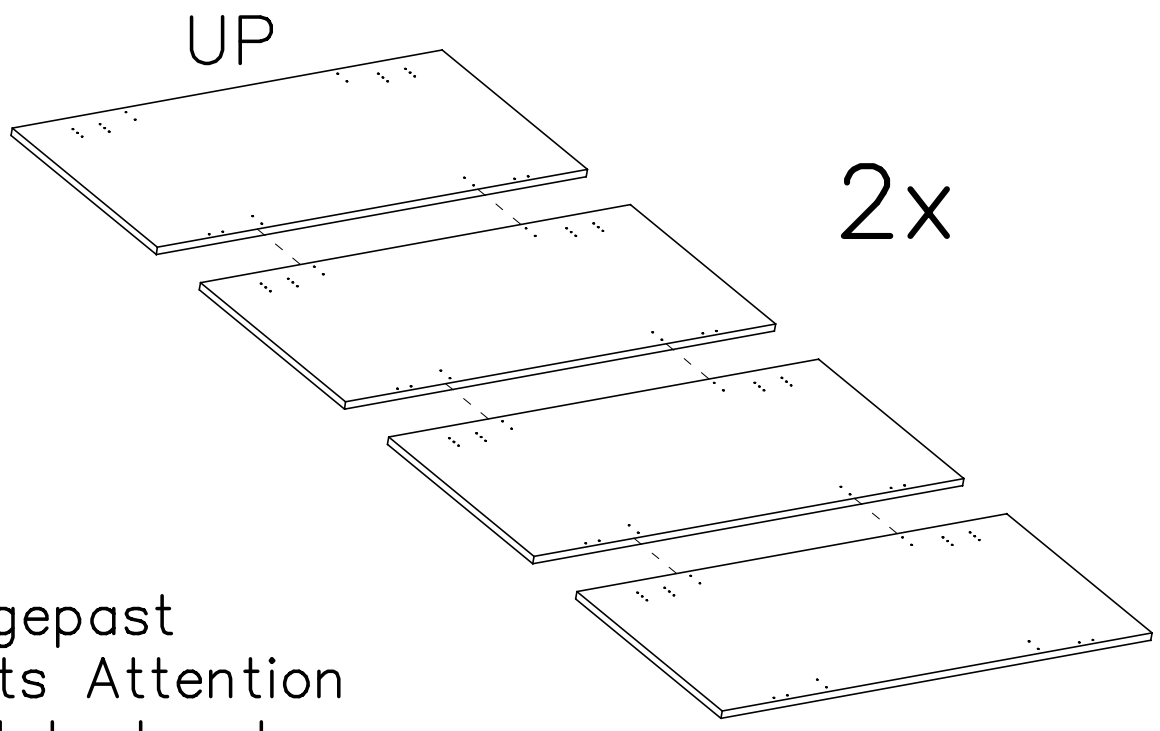
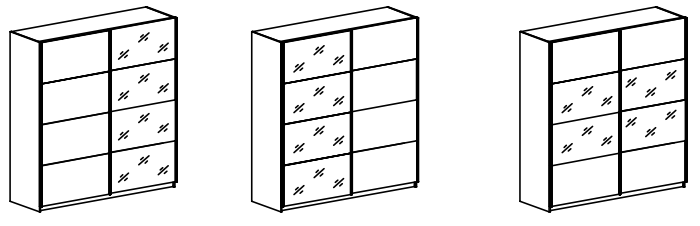

Opgepast
Fait's Attention
Watched out

24

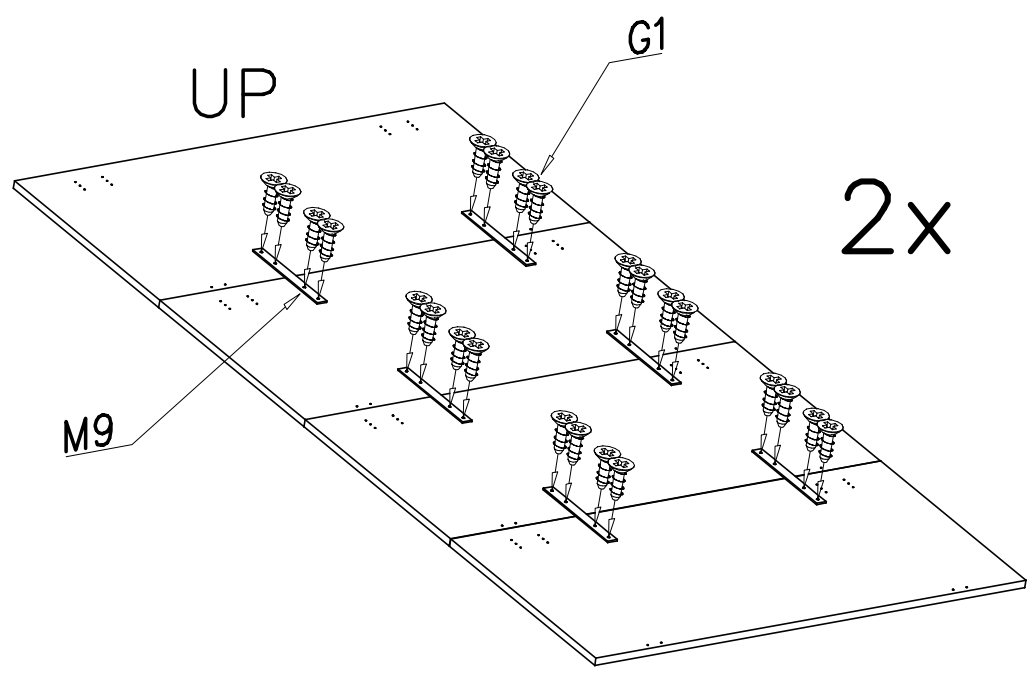

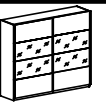

T28

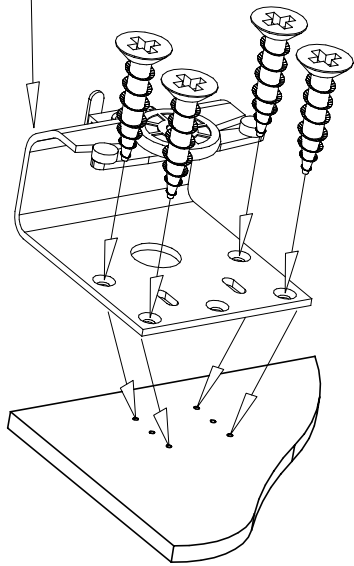

Linkse deur
Porte gauche
Left door

T30

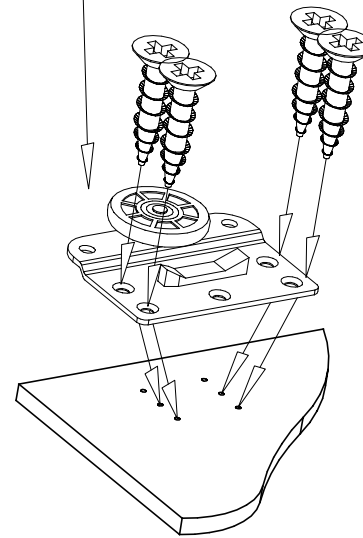

Rechtse deur
Porte droite
Right door

T29

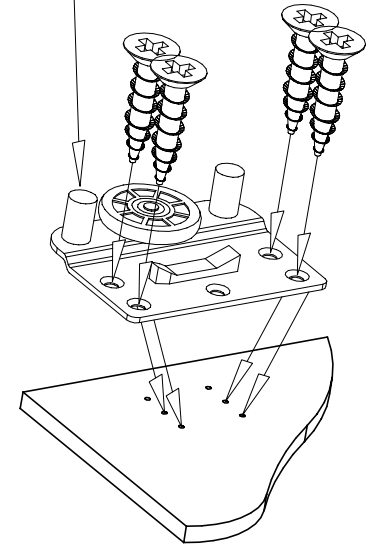

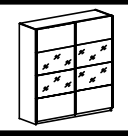

25

Rechtse deur
Porte droite
Right door

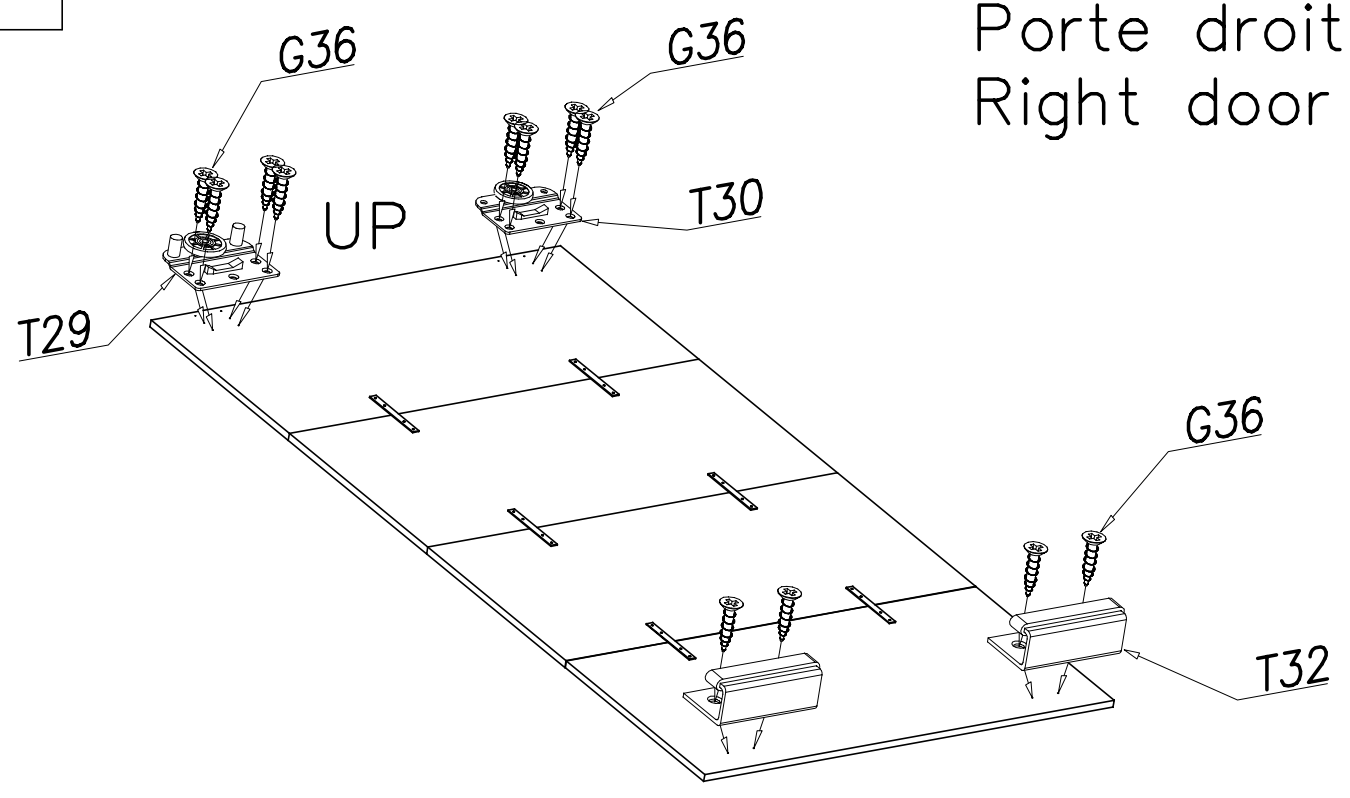

26

Linkse deur
Porte gauche
Left door

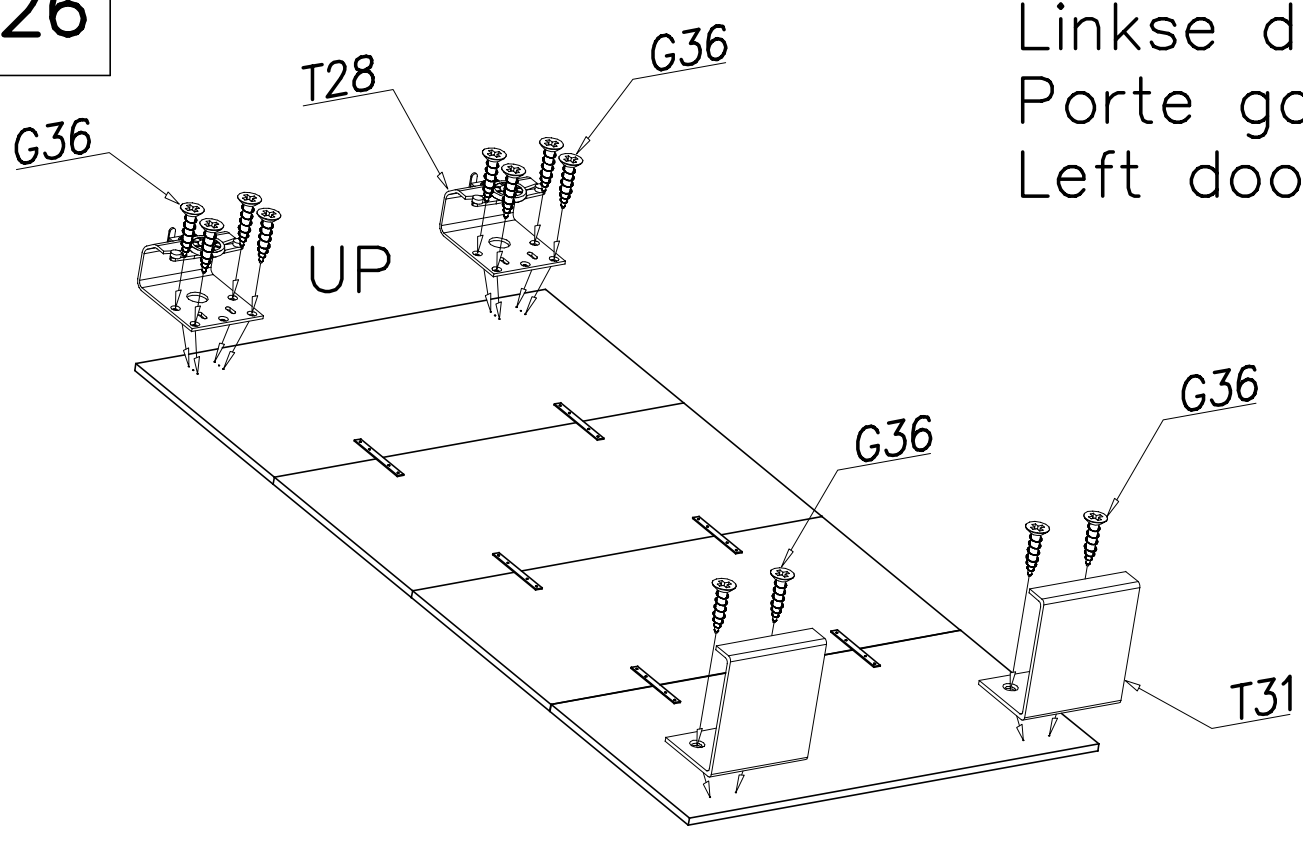

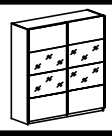

27

Rechtse deur
Porte droite
Right door

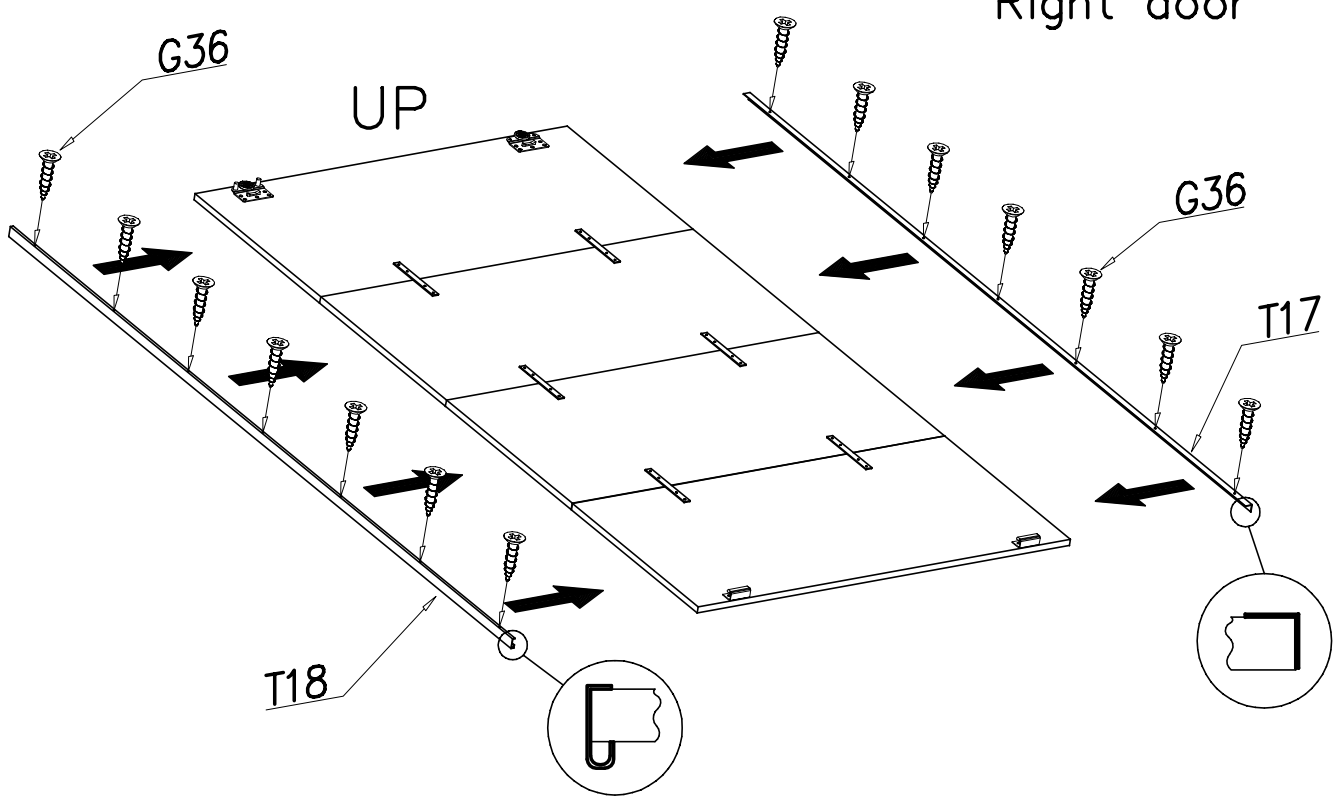

28

Linkse deur
Porte gauche
Left door

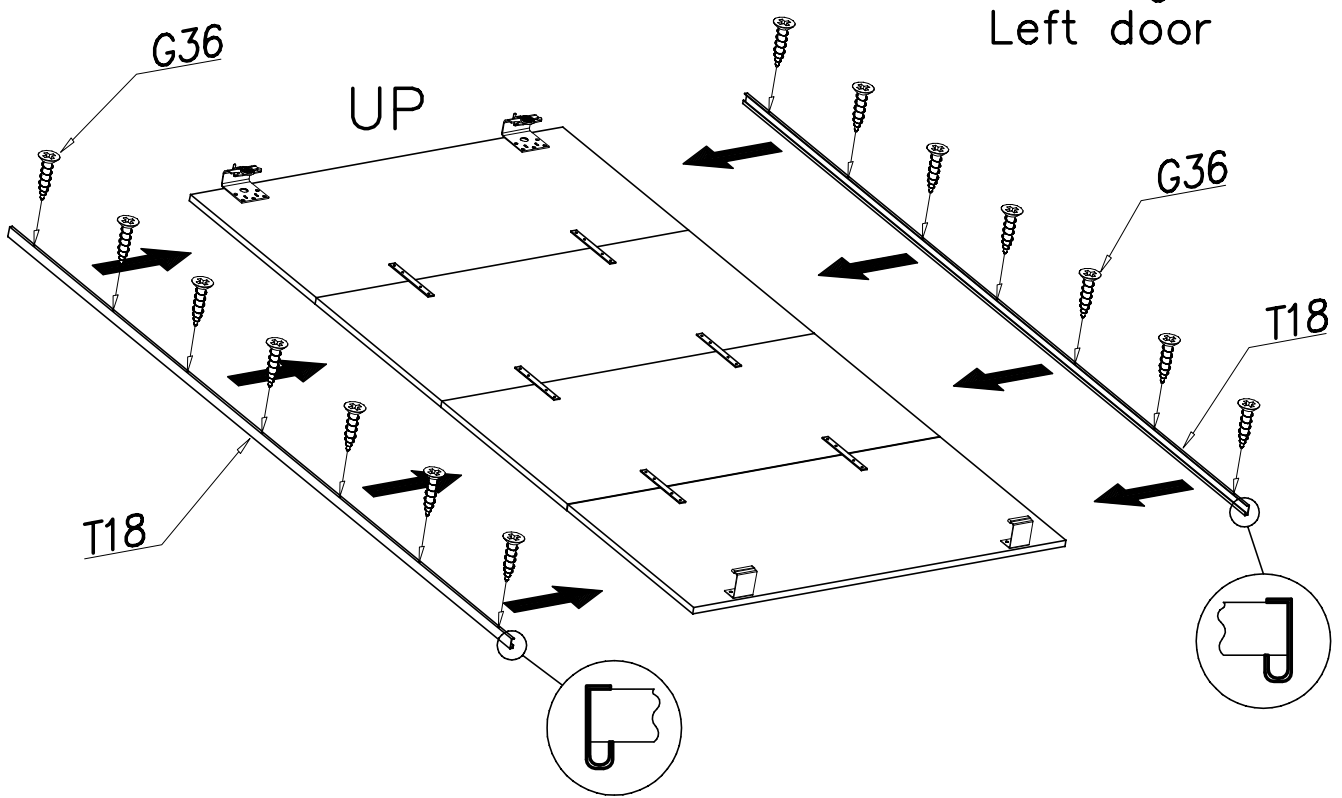

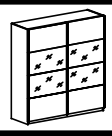

29

Rechtse deur
Porte droite
Right door

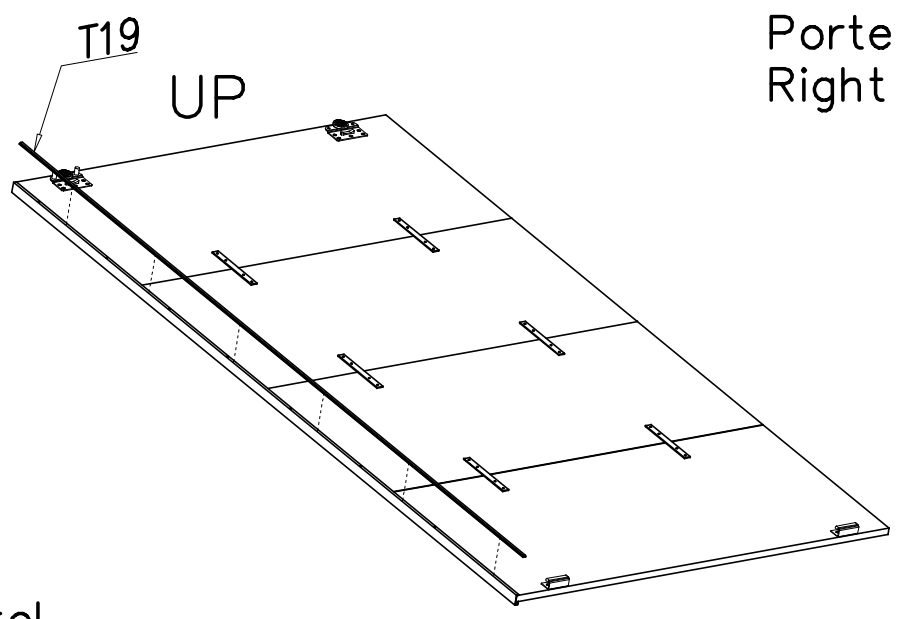

Stofborstel
La brosse de substance
Substance brusch

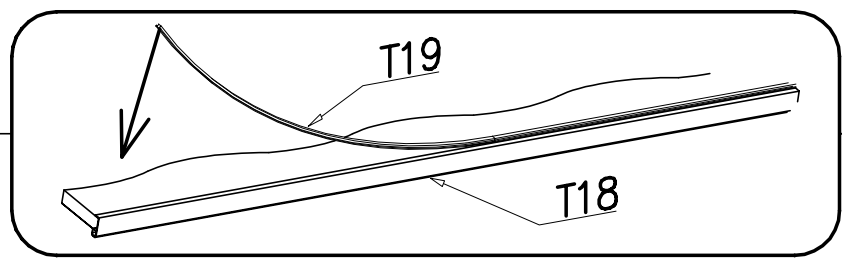

30

Stofborstel
La brosse de substance
Substance brusch

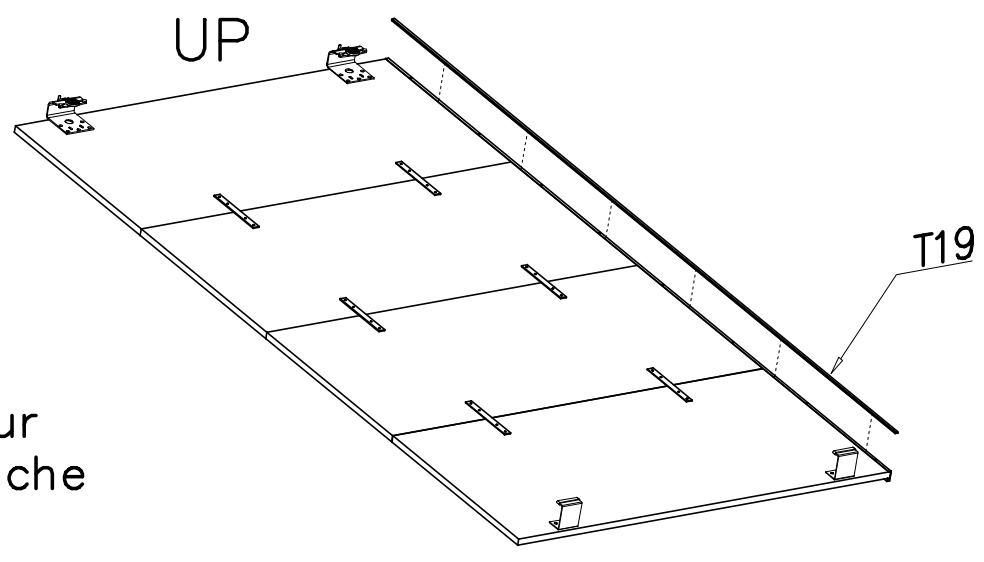

Linkse deur
Porte gauche
Left door



31

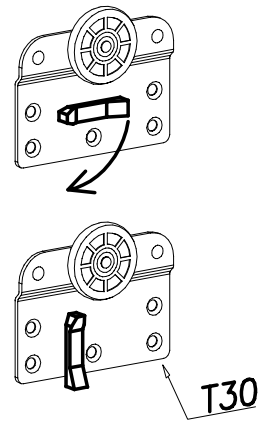
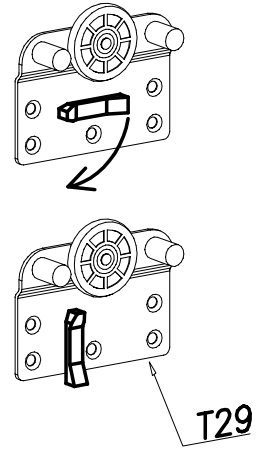
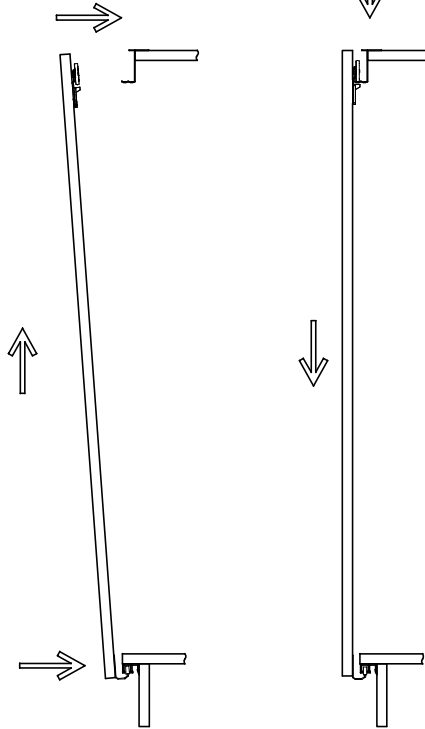
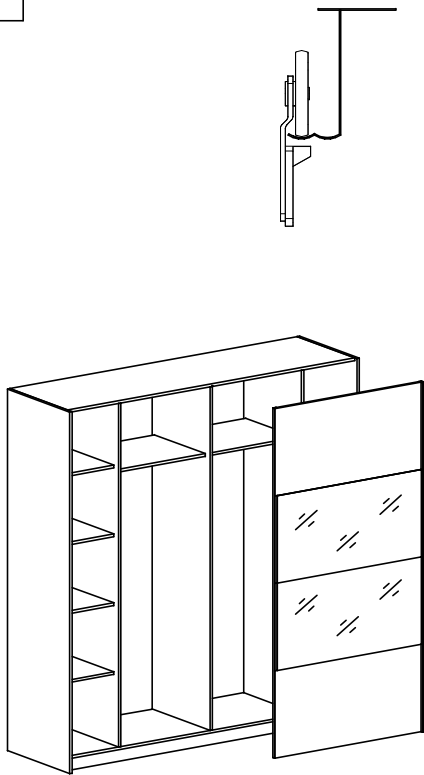

32

