

# BED FRAME

## KING

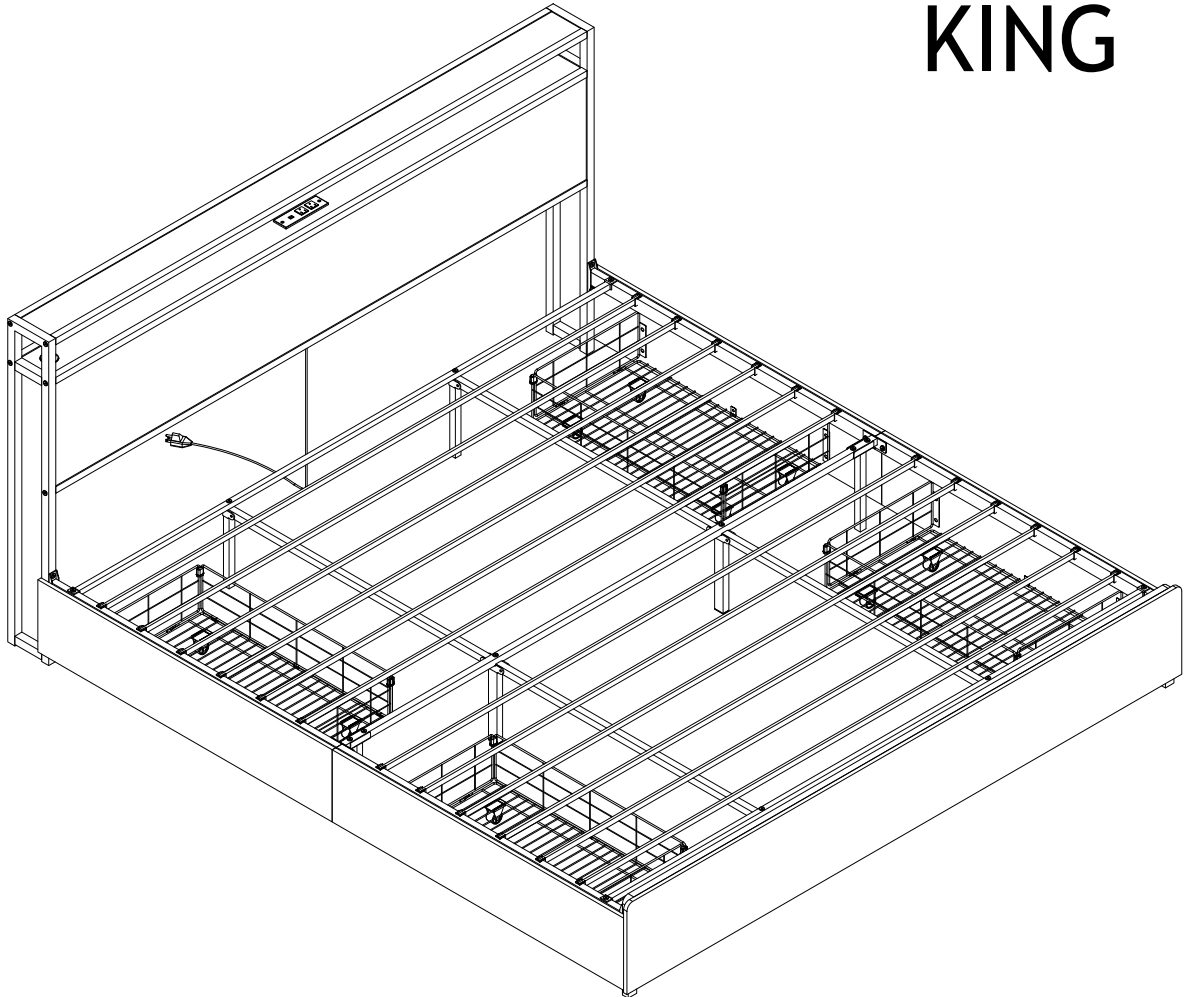

## Before You Start

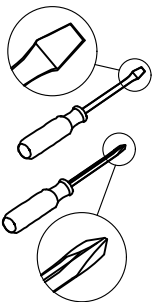

- ✓ Read through each step carefully and follow the proper order
- ✓ Separate and count all your parts and hardware
- ✓ Give yourself enough room for the assembly process
- ✓ Have the following tools: Flat Head Screwdriver, #2 Phillips Head Screwdriver and Hammer
- ✓ Caution: If using a power drill or power screwdriver for screwing, please be aware of to slow down and stop when screw is tight. Failure to do so may result in stripping the screw. (Assembly speed can be increased by using electric screwdriver)

# Parts Identification 1/2

Not actual size

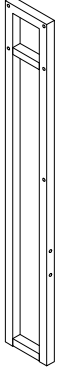
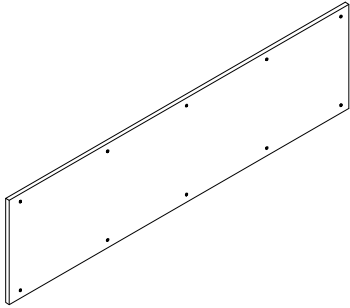
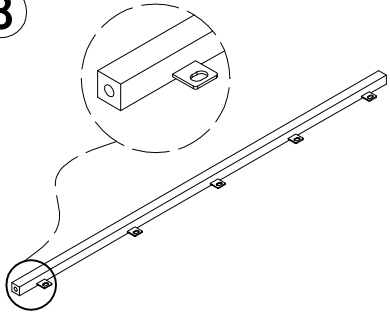
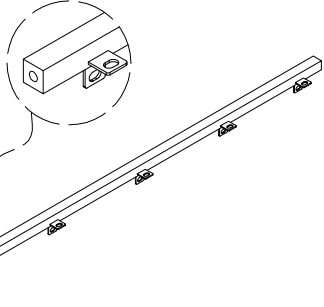
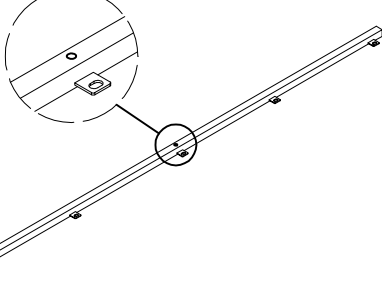
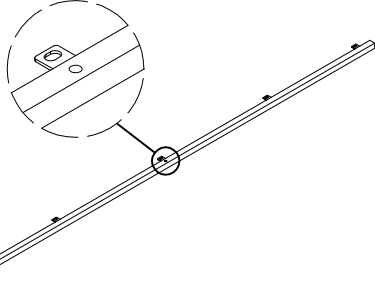
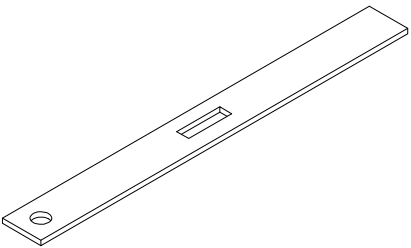
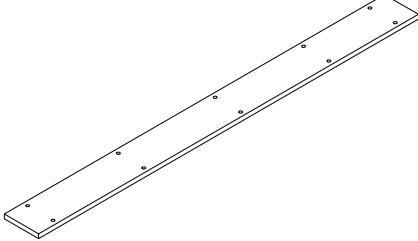
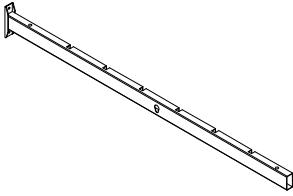
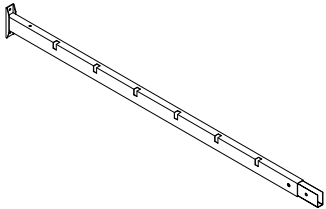
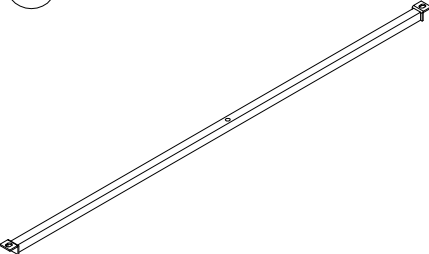
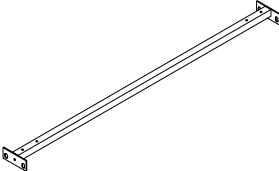
<p>①</p>  <p>Q'ty: 2</p>	<p>②</p>  <p>Q'ty: 1</p>	<p>③</p>  <p>Q'ty: 2</p>
<p>④</p>  <p>Q'ty: 1</p>	<p>⑤</p>  <p>Q'ty: 1</p>	<p>⑥</p>  <p>Q'ty: 1</p>
<p>⑦</p>  <p>Q'ty: 1</p>	<p>⑧</p>  <p>Q'ty: 1</p>	<p>⑨</p>  <p>Q'ty: 2</p>
<p>⑩</p>  <p>Q'ty: 2</p>	<p>⑪</p>  <p>Q'ty: 2</p>	<p>⑫</p>  <p>Q'ty: 1</p>

# Parts Identification 2/2

Not actual size

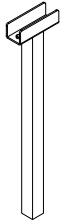
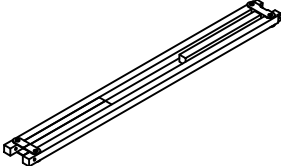
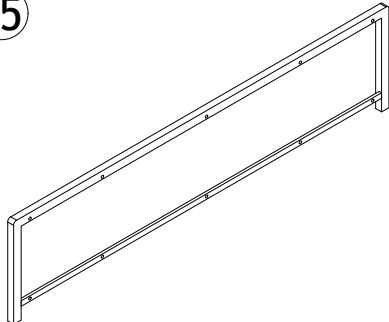
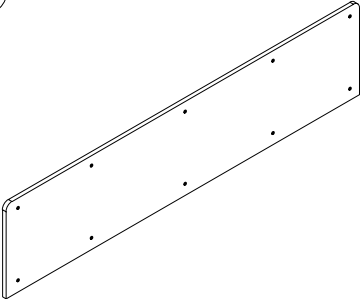
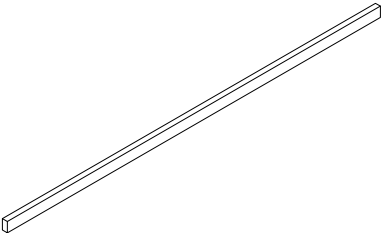
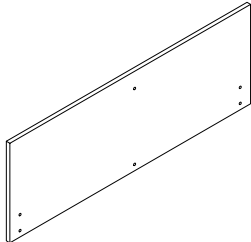
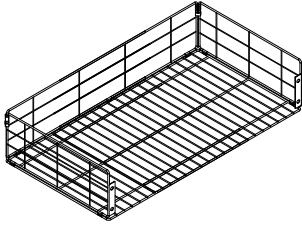
<p>13</p>  <p>Q'ty: 2</p>	<p>14</p>  <p>Q'ty: 2</p>	<p>15</p>  <p>Q'ty: 1</p>
<p>16</p>  <p>Q'ty: 1</p>	<p>17</p>  <p>Q'ty: 12</p>	<p>18</p>  <p>Q'ty: 4</p>
<p>19</p>  <p>Q'ty: 4</p>		

# Parts Identification

Not actual size

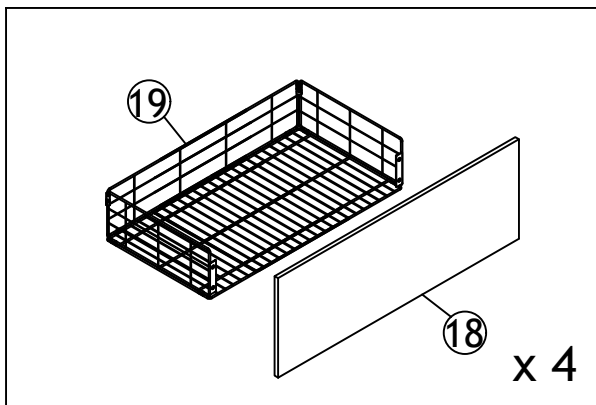
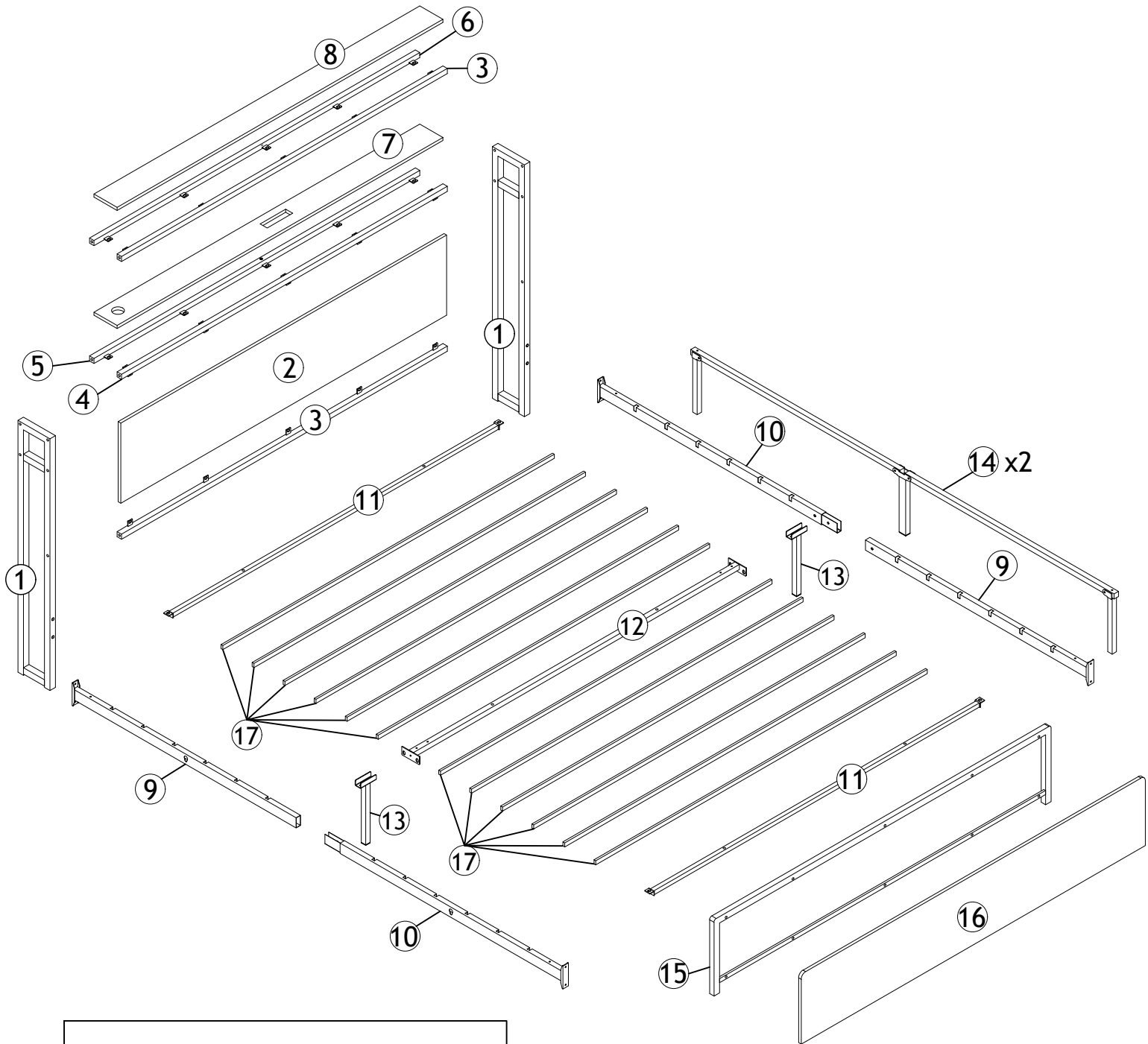

# Hardware List

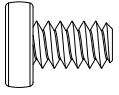

Ø1/4" x 11mm

(A)

x 52

BOLT  
spare: 2

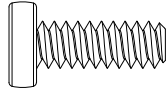

Ø1/4" x 16mm

(B)

x 17

BOLT  
spare: 2

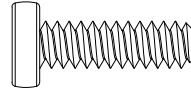

Ø1/4" x 25mm

(C)

x 4

BOLT  
spare: 1

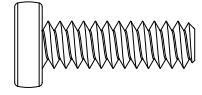

Ø1/4" x 28mm

(D)

x 5

BOLT  
spare: 1

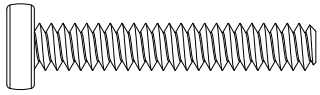

Ø1/4" x 50mm

(E)

x 16

BOLT  
spare: 2

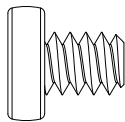

M8 x 13mm

(F)

x 4

BOLT  
spare: 1

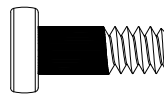

Ø1/4" x 16mm

(G)

x 4

BOLT  
spare: 1

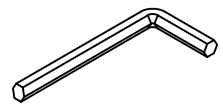

M4

(H)

x 1

ALLEN KEY

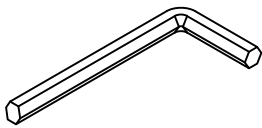

M5

(I)

x 1

ALLEN KEY



Ø3 x 12mm

(J)

x 2

SOCKET

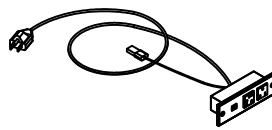

(K)

x 1

SOCKET



(L)

x 1

LED STRIP

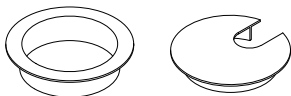

(M)

x 1

CABLE HOLE COVER

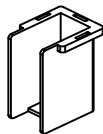

(N)

x 24

PLASTIC CAP

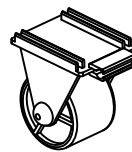

(O)

x 16

CASTER

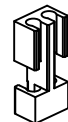

(P)

x 8

DRAWER CLIP



(Q)

x 4

DRAWER CLIP



(R)

x 1

SUPPORTER

# STEP 1

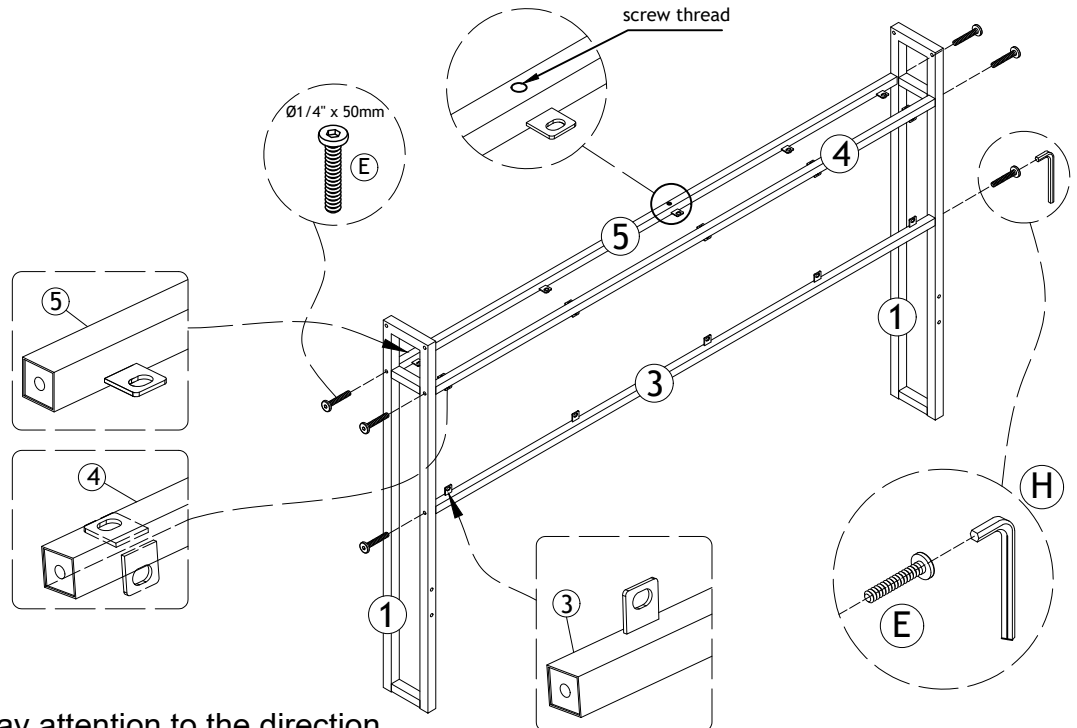
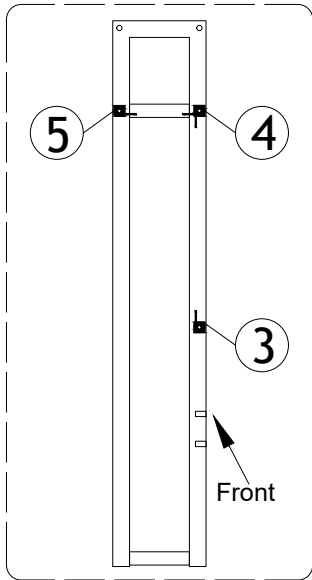
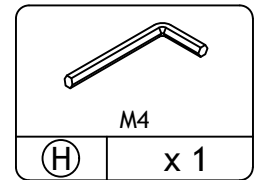
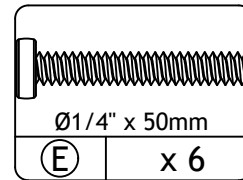
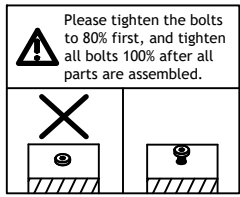

# STEP 2

Please pay attention to the direction of the metal bolt plate.

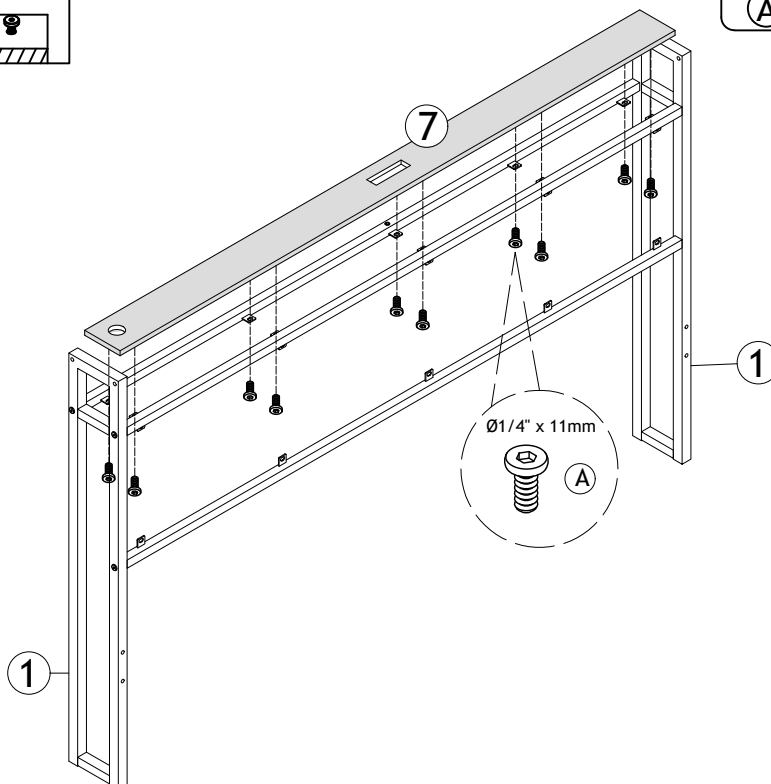
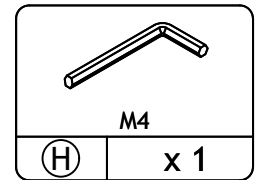
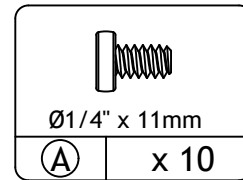
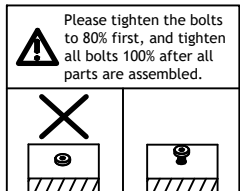

# STEP 3

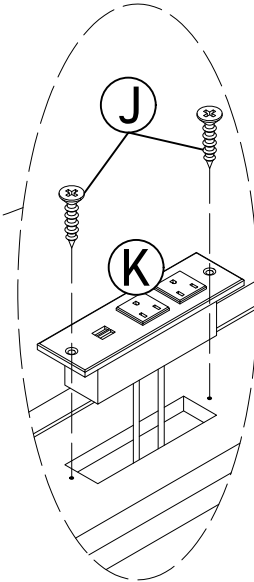
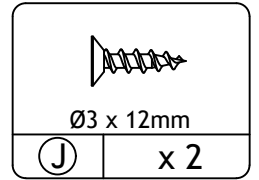
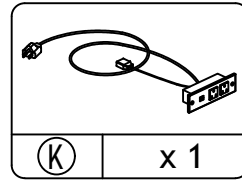
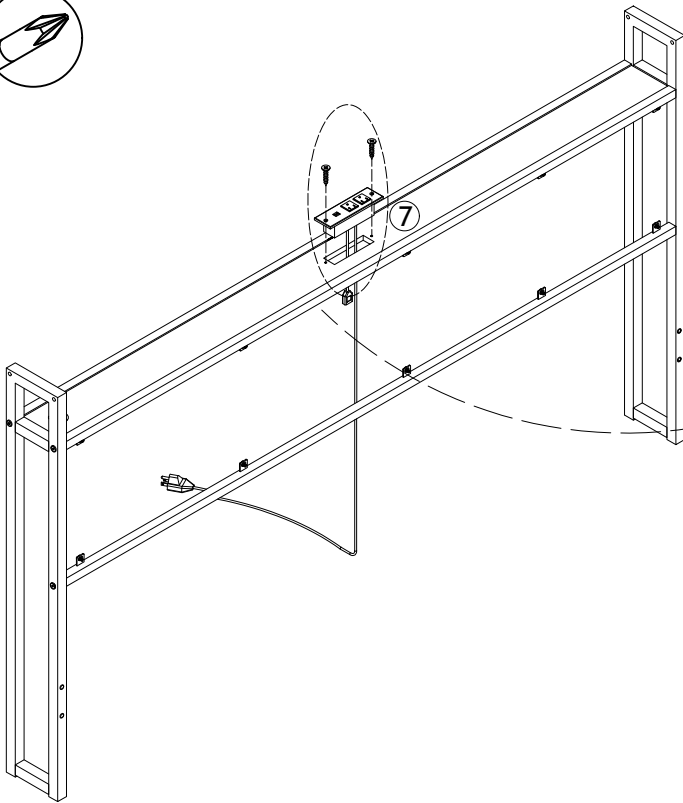
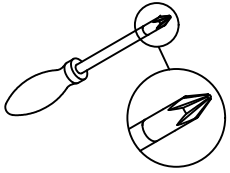

# STEP 4

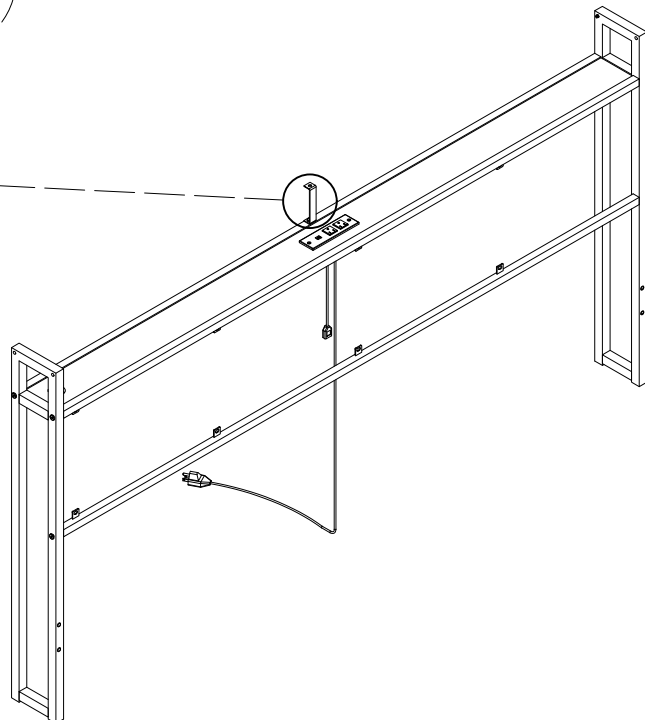
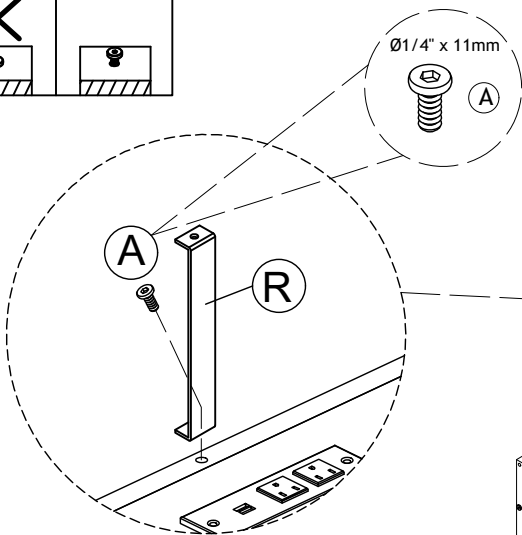
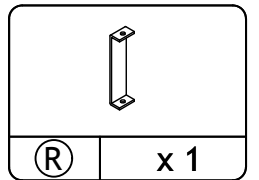
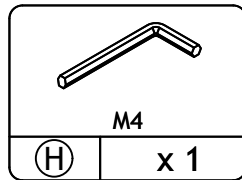
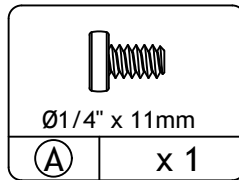
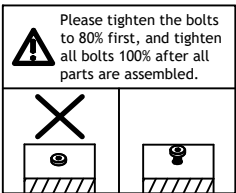

# STEP 5

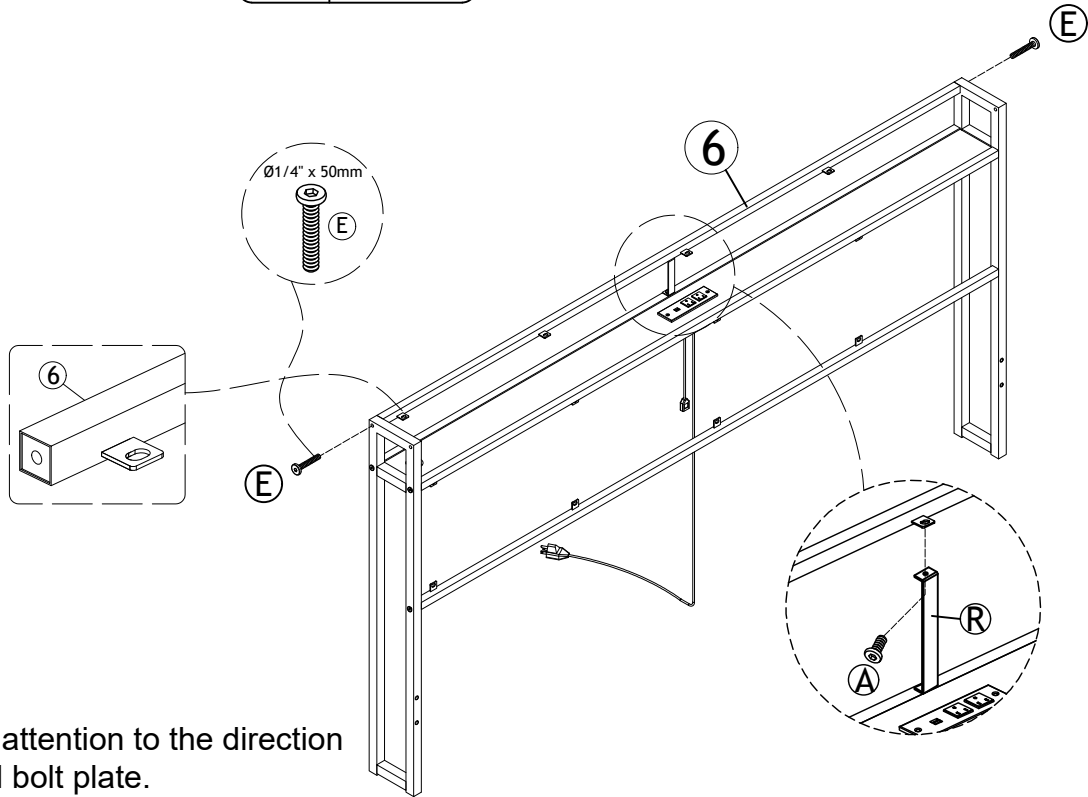
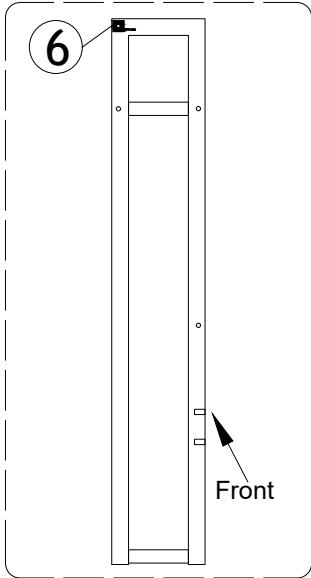
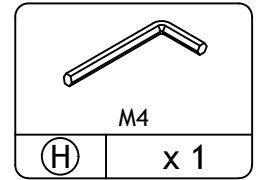
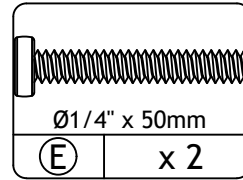
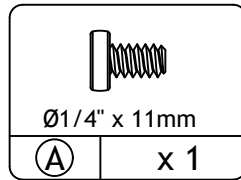
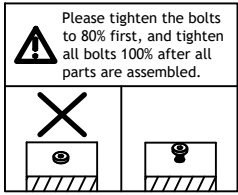

**STEP 6** Please pay attention to the direction of the metal bolt plate.

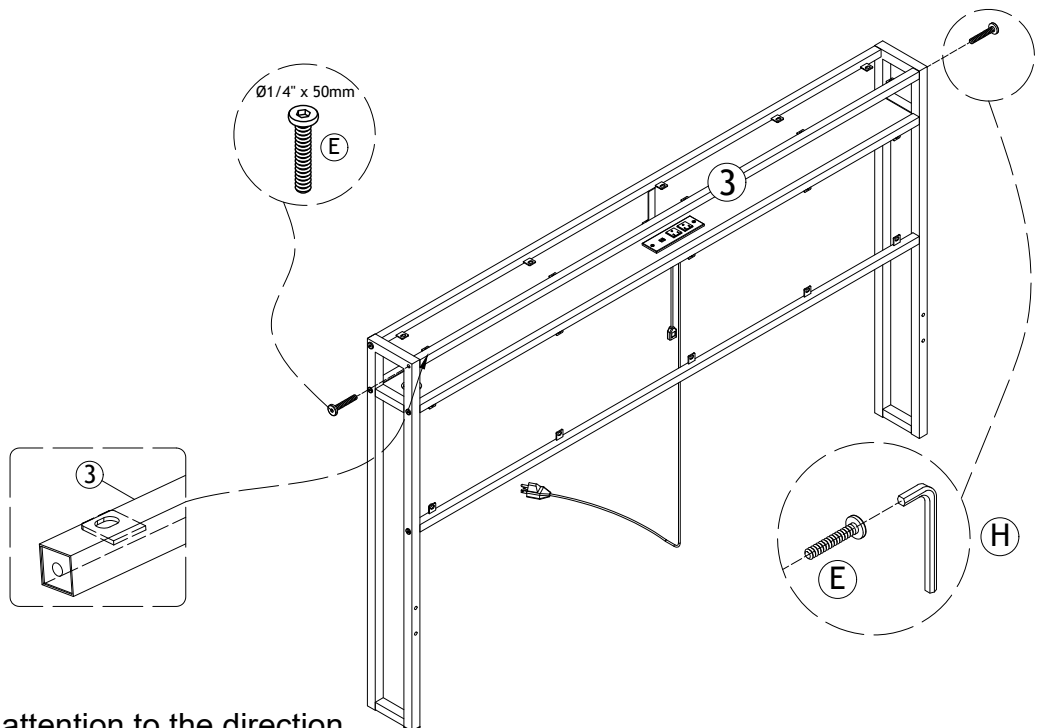
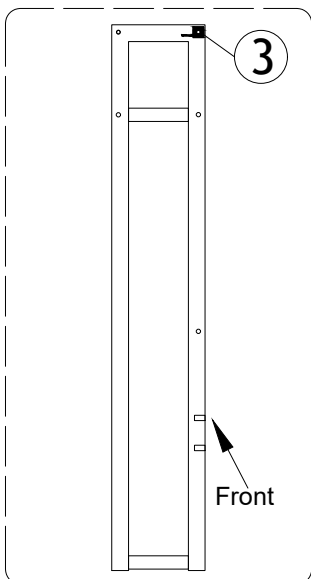
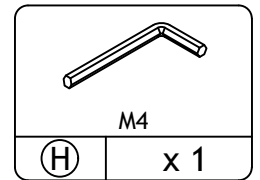
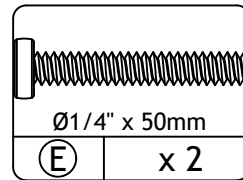
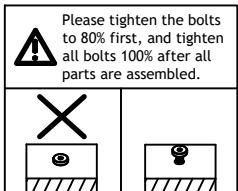



Please pay attention to the direction of the metal bolt plate.

# STEP 7

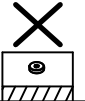
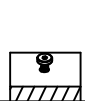
 Please tighten the bolts to 80% first, and tighten all bolts 100% after all parts are assembled.

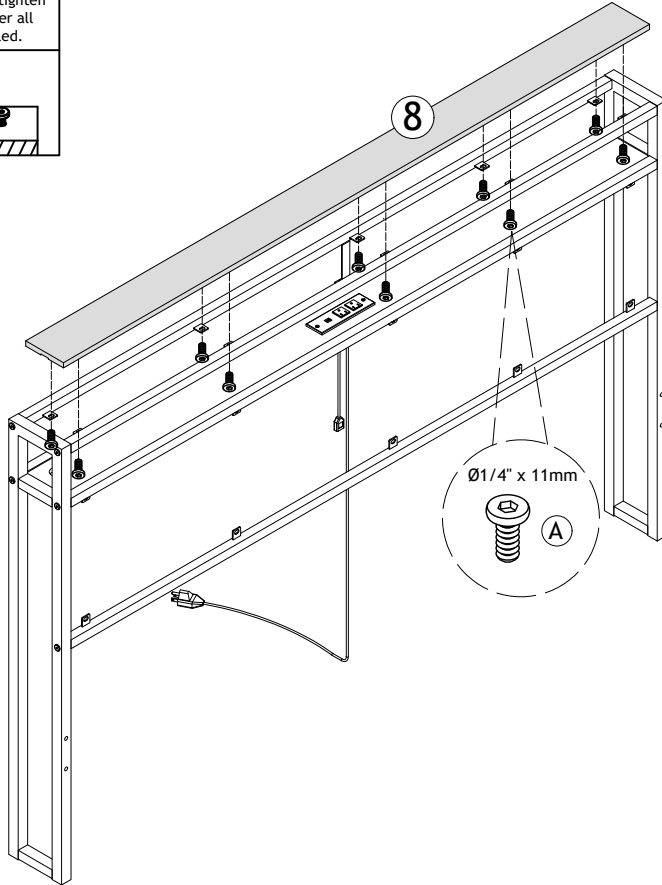
	
---	---





Ø1/4" x 11mm
(A) x 10

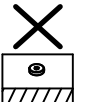
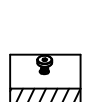

M4
(H) x 1

# STEP 8

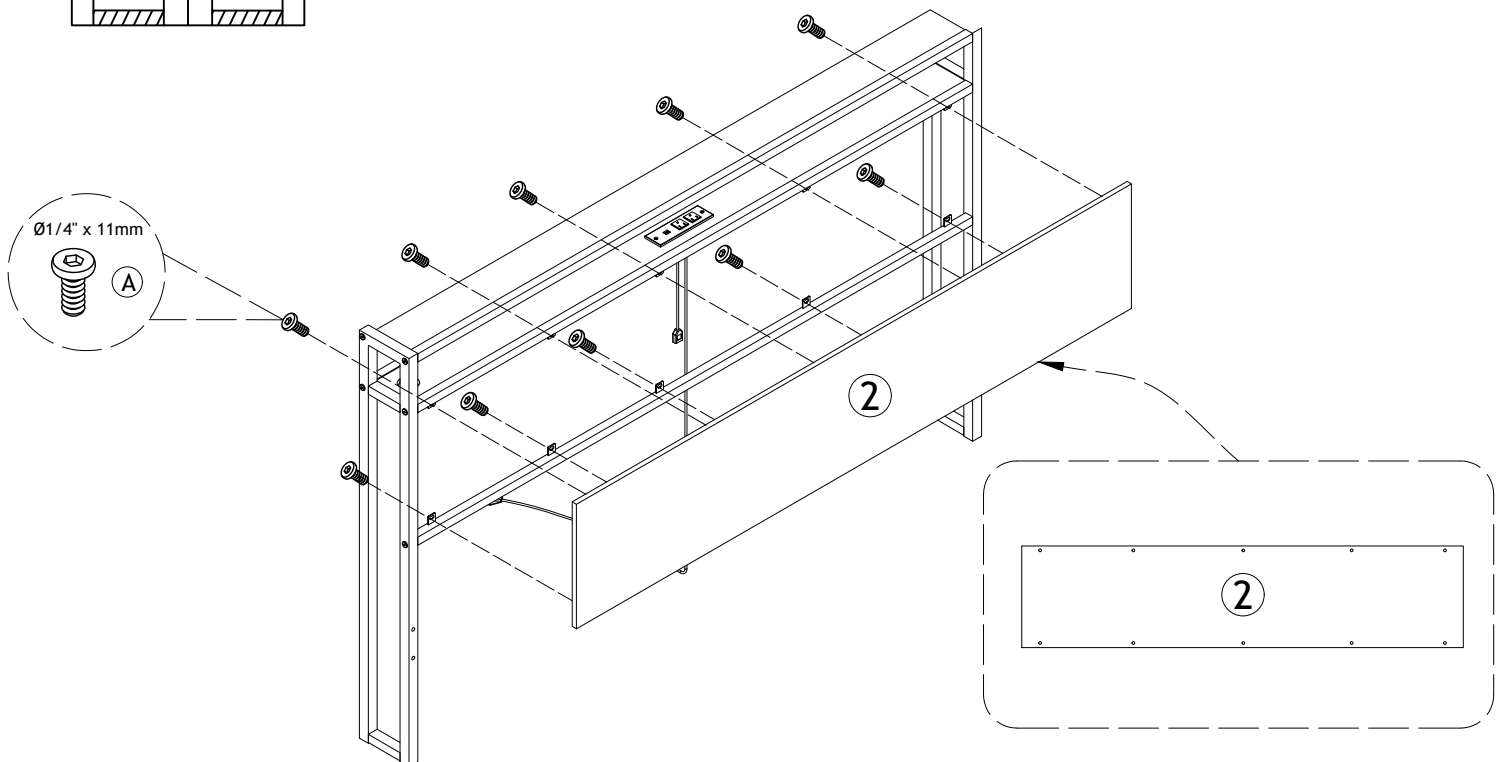
 Please tighten the bolts to 80% first, and tighten all bolts 100% after all parts are assembled.

	
---	---



Ø1/4" x 11mm
(A) x 10

M4
(H) x 1

# STEP 9

⚠ Please tighten the bolts to 80% first, and tighten all bolts 100% after all parts are assembled.

Ø1/4" x 16mm

(B)	x 4
-----	-----

M4

(H)	x 1
-----	-----

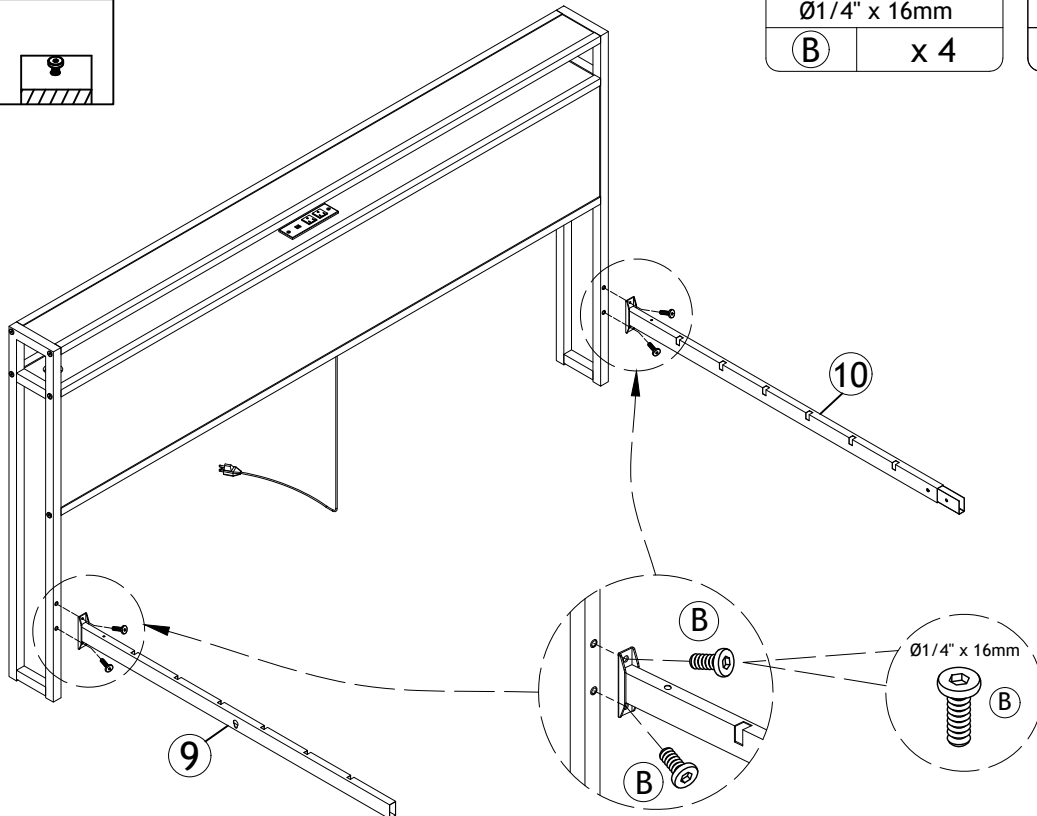

# STEP 10

⚠ Please tighten the bolts to 80% first, and tighten all bolts 100% after all parts are assembled.

Ø1/4" x 16mm

(B)	x 5
-----	-----

Ø1/4" x 28mm

(D)	x 5
-----	-----

M4

(H)	x 1
-----	-----

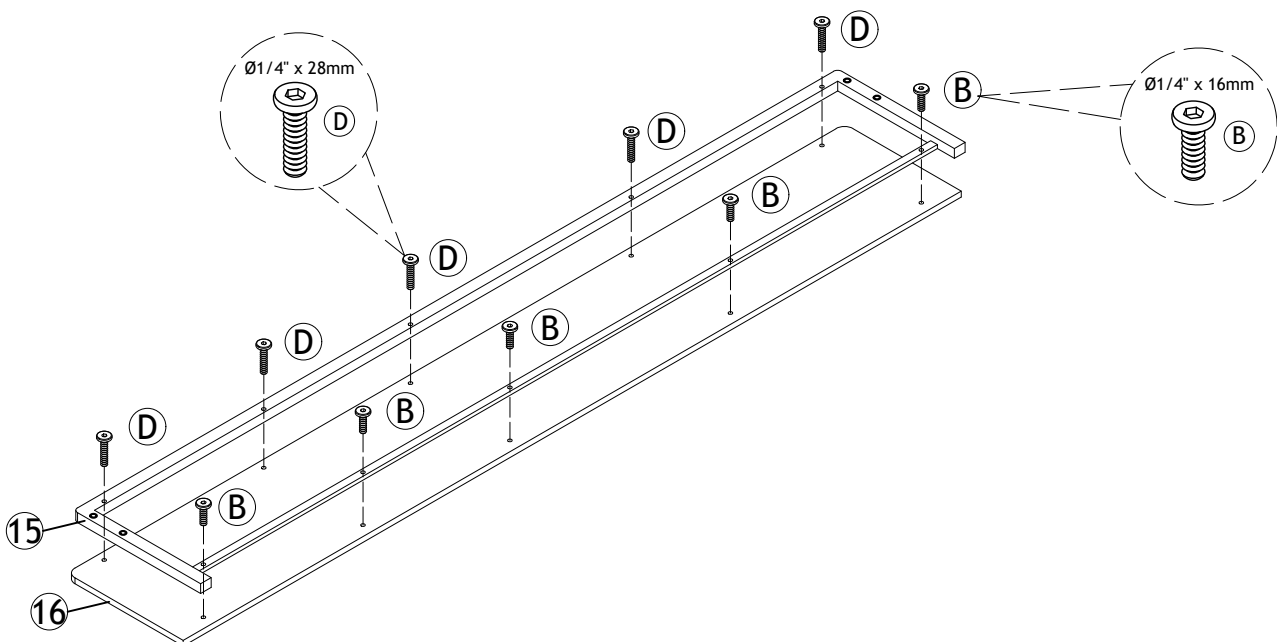

# STEP 11

 Please tighten the bolts to 80% first, and tighten all bolts 100% after all parts are assembled.

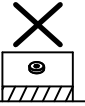
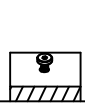
	
---	---

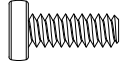
Ø1/4" x 16mm
(B) x 4

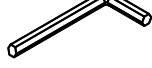

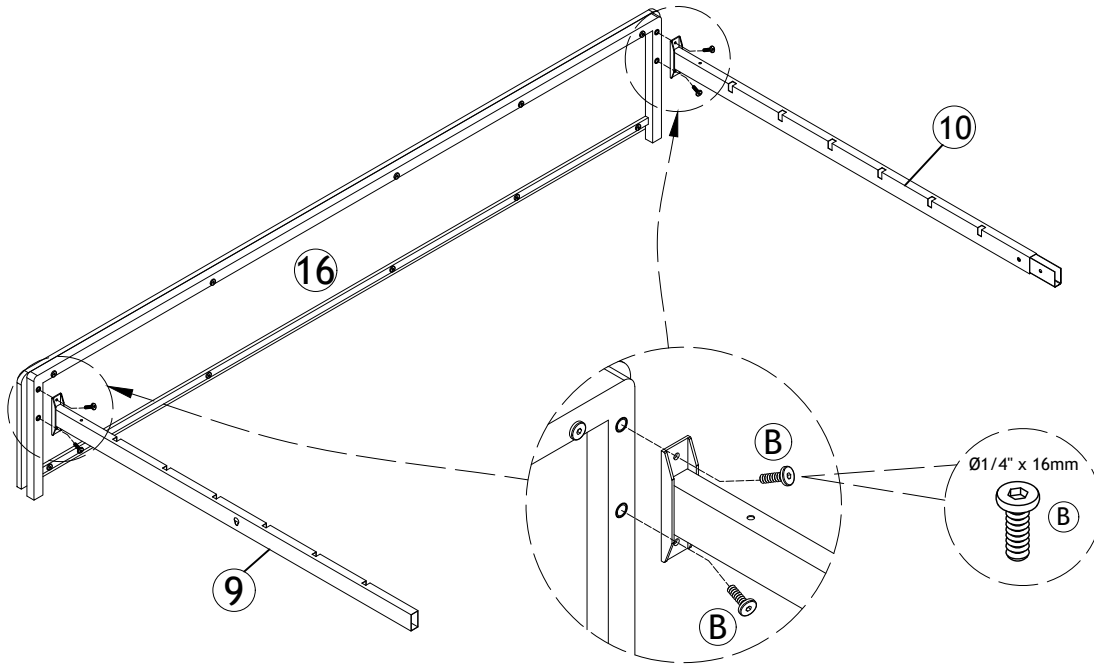
M4
(H) x 1

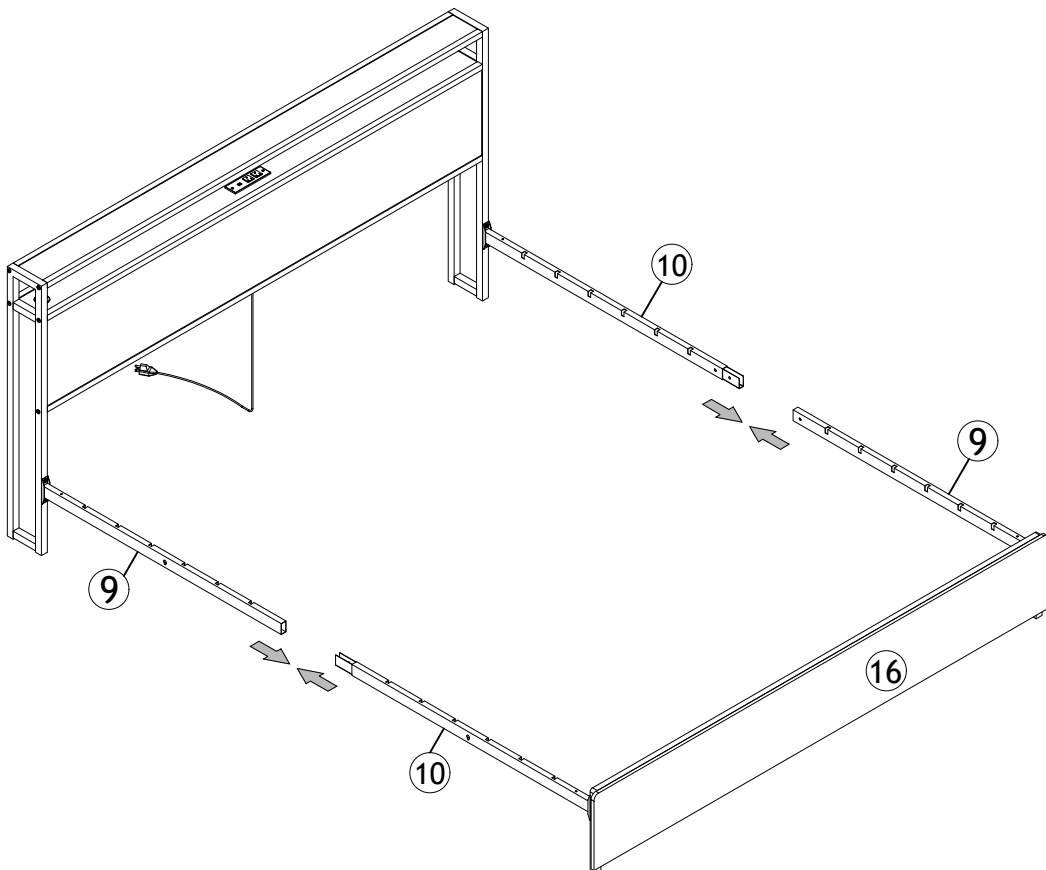

# STEP 12

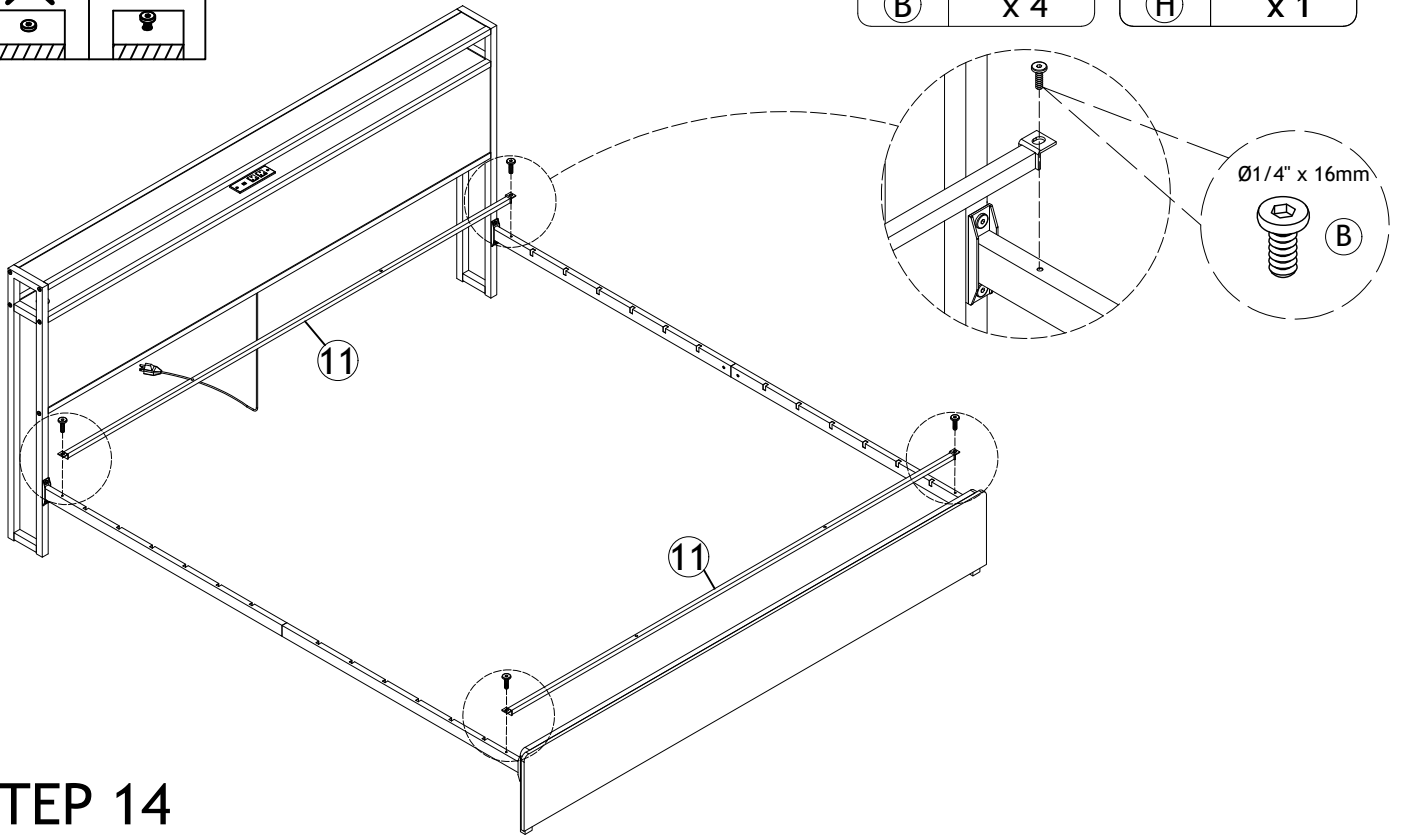
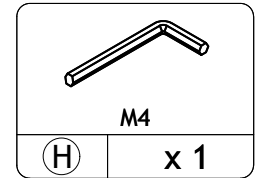
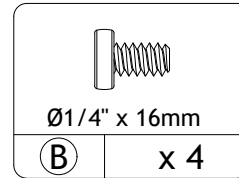
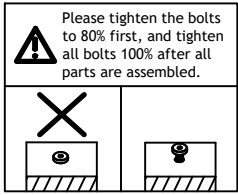

# STEP 13



# STEP 14

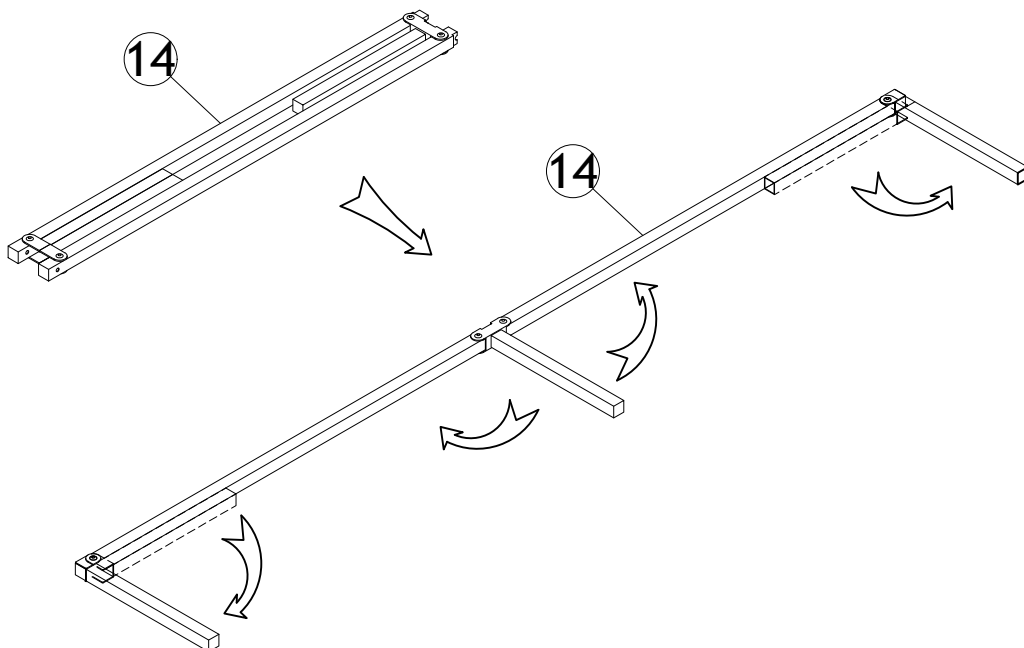

Expand the folded portion

**x 2**

# STEP 15

⚠ Please tighten the bolts to 80% first, and tighten all bolts 100% after all parts are assembled.

Ø1/4" x 50mm  
E x 4

M4  
H x 1

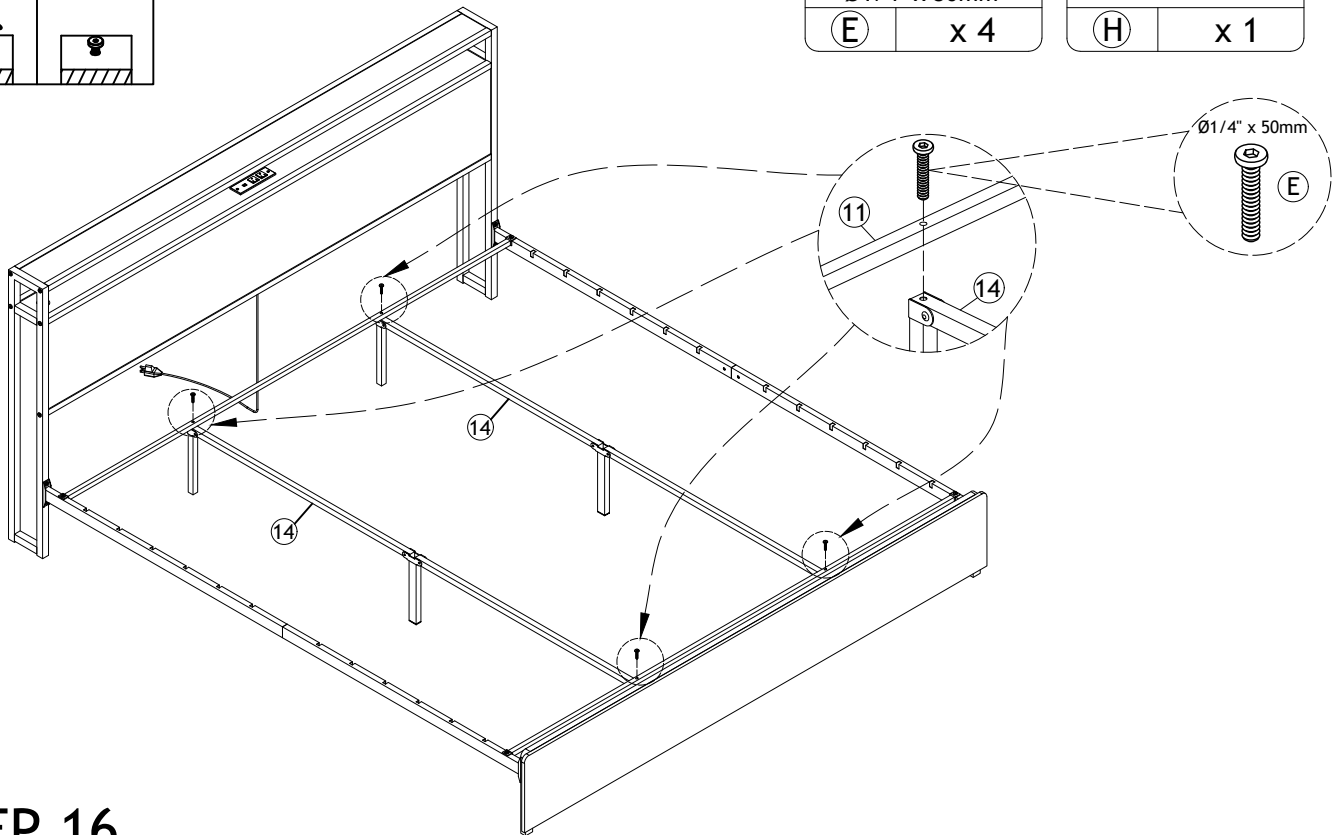

# STEP 16

⚠ Please tighten the bolts to 80% first, and tighten all bolts 100% after all parts are assembled.

Ø1/4" x 25mm  
C x 4

M4  
H x 1

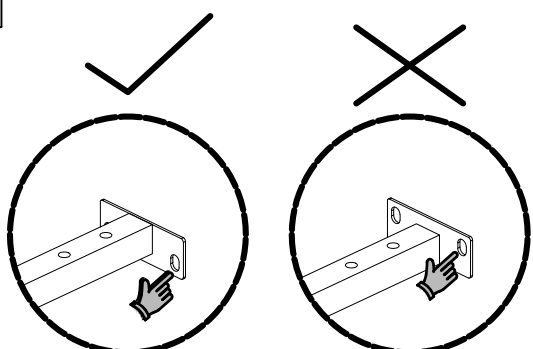
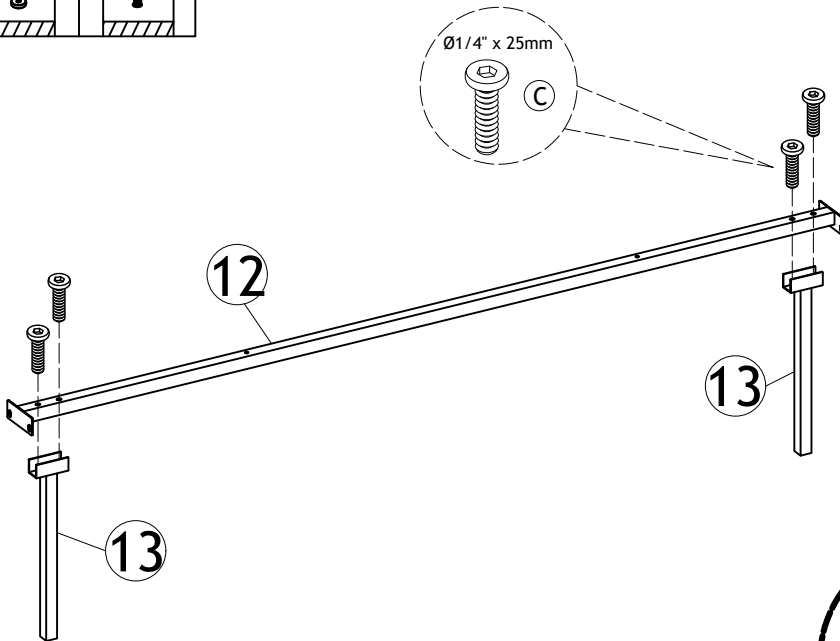

**ATTENTION:** This metal plate is on the bottom instead of on top. Don't install it wrongly.

# STEP 17

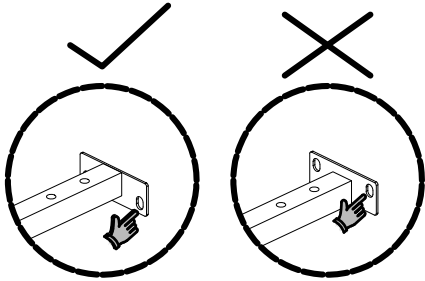
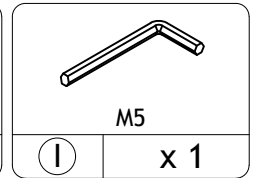
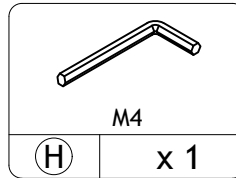
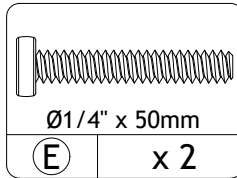
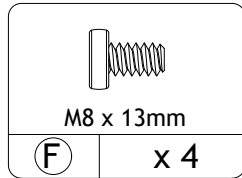
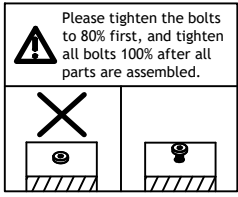

**ATTENTION:** This metal plate is on the bottom instead of on top. Don't install it wrongly.

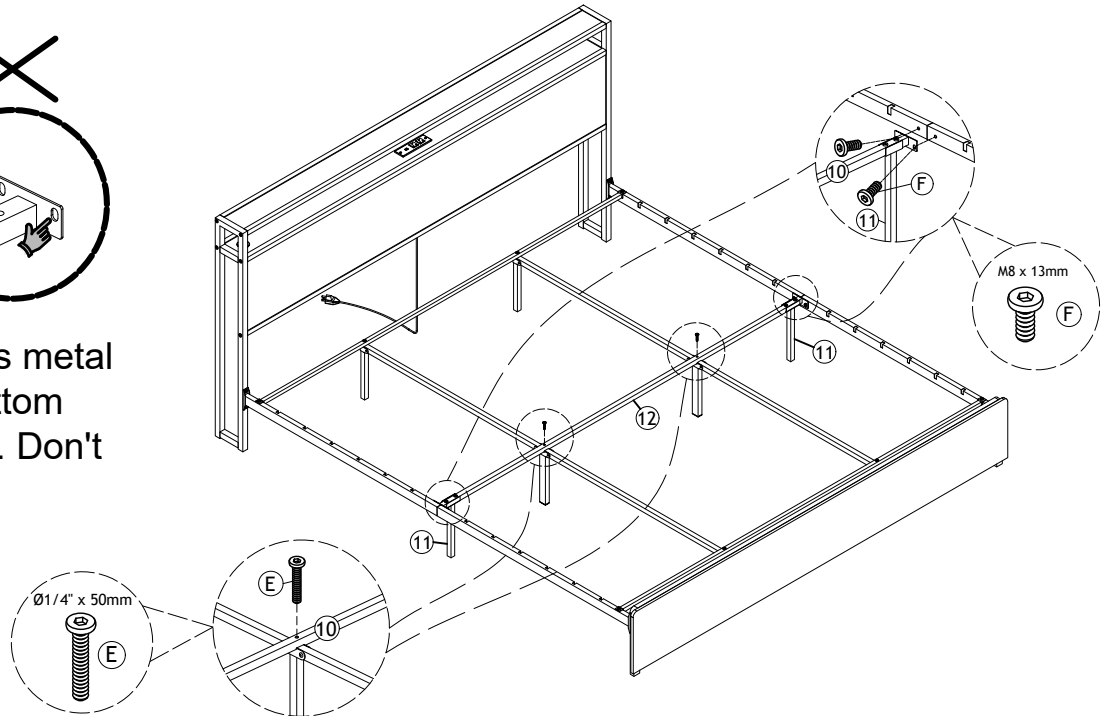

# STEP 18

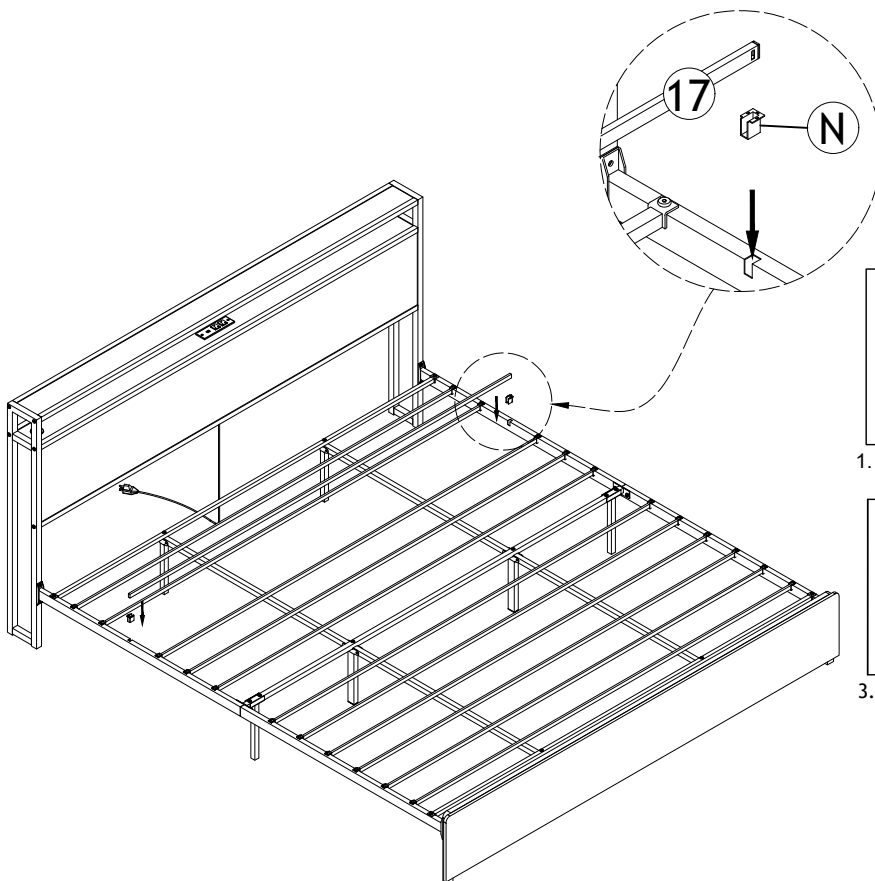
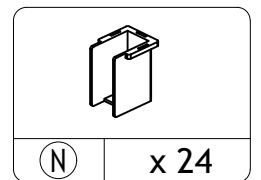

Assemble the slats

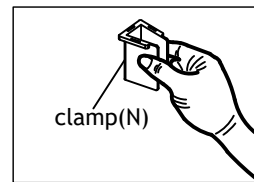

1. Squeeze the clamp (N) tightly.

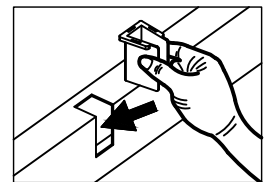

2. Put the clamp into the gaps.

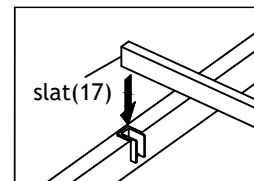

3. Put the slat (17) into the clamp.

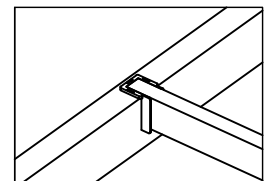

4. Finished.

# STEP 19

Expand the drawer frame

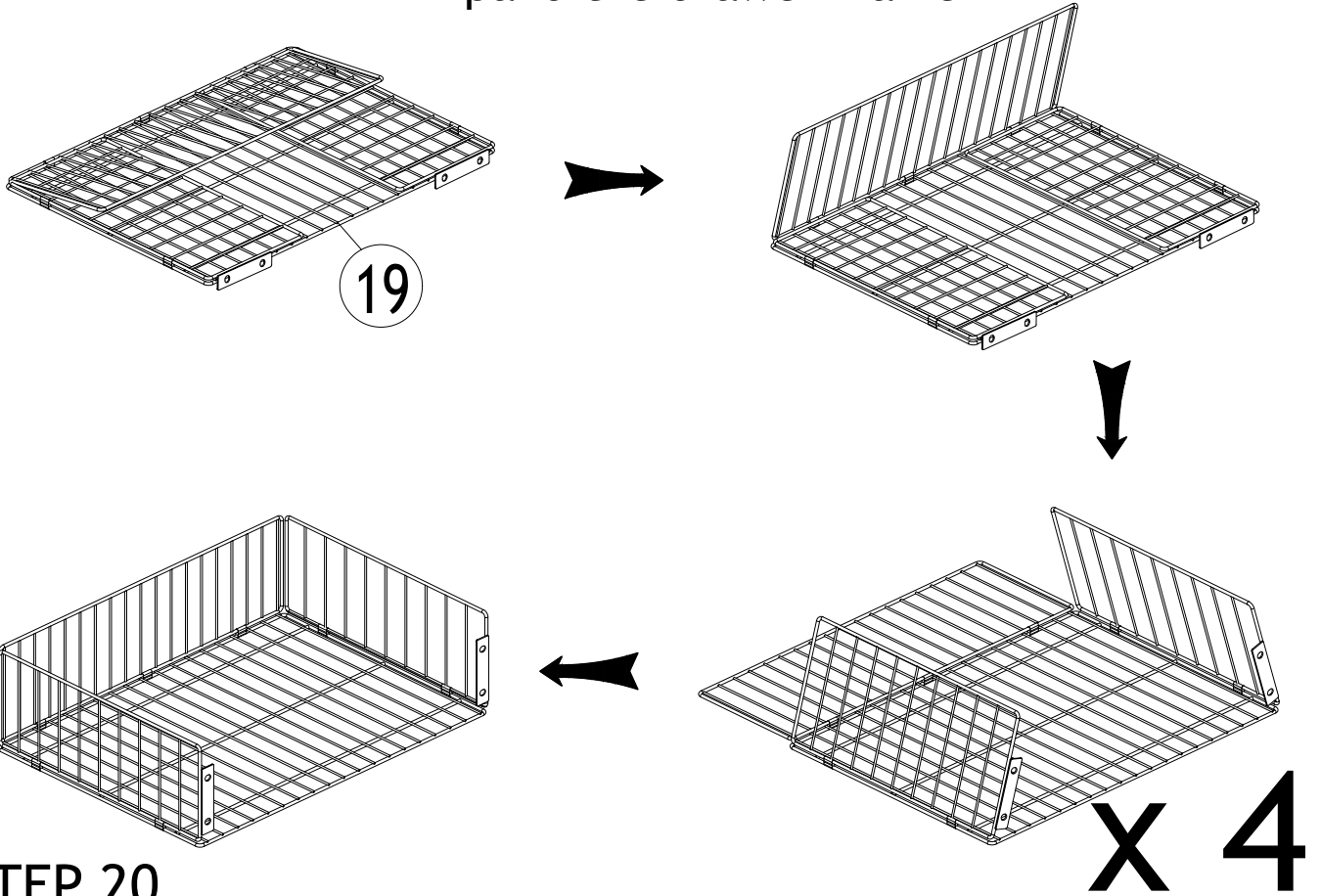

# STEP 20

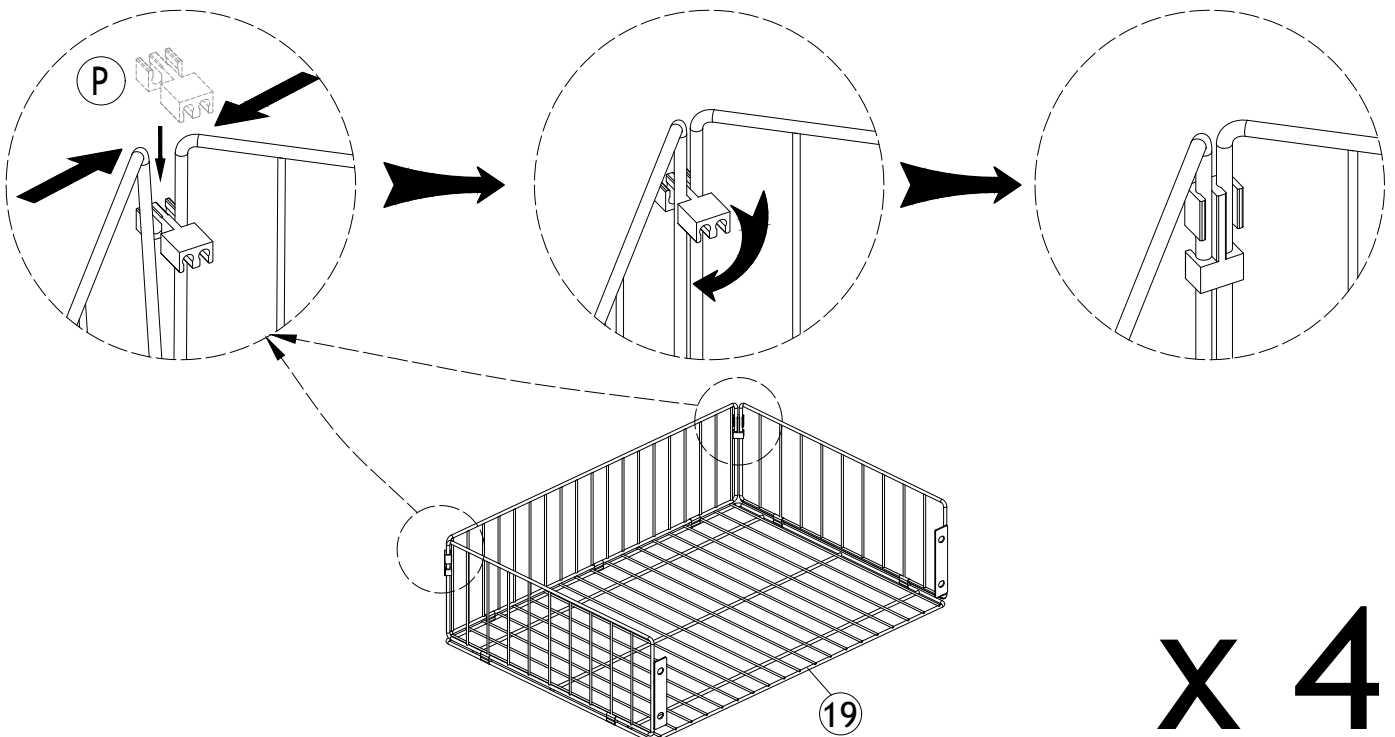
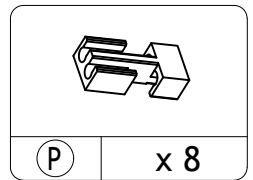

# STEP 21

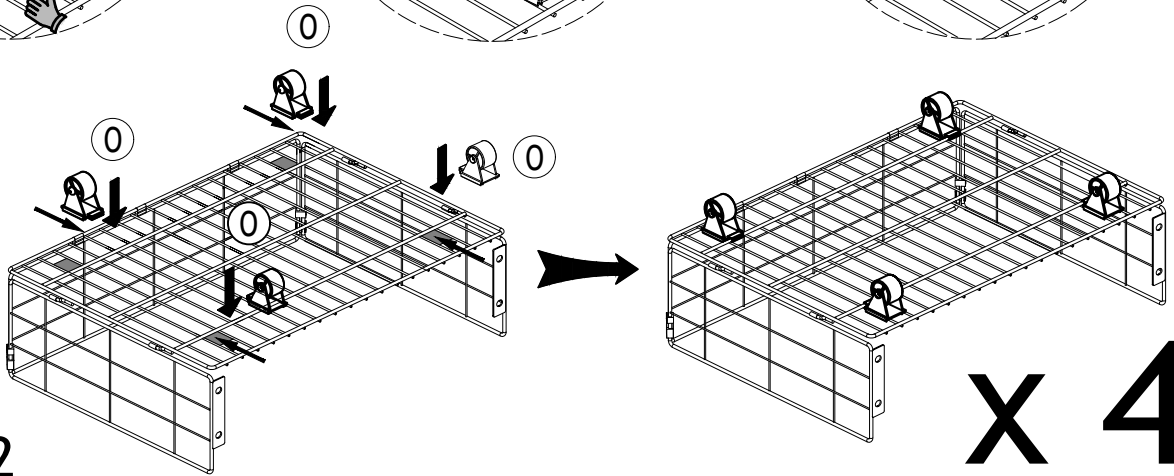
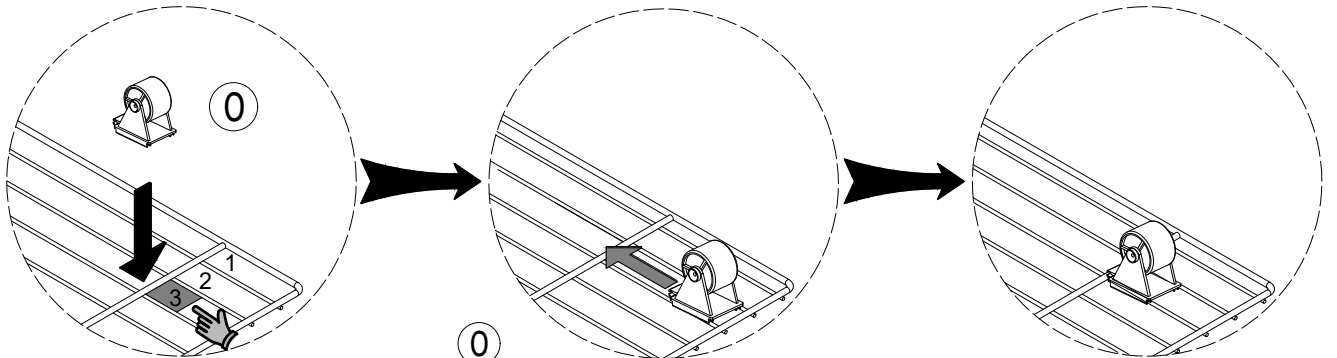
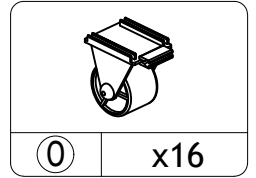

# STEP 22

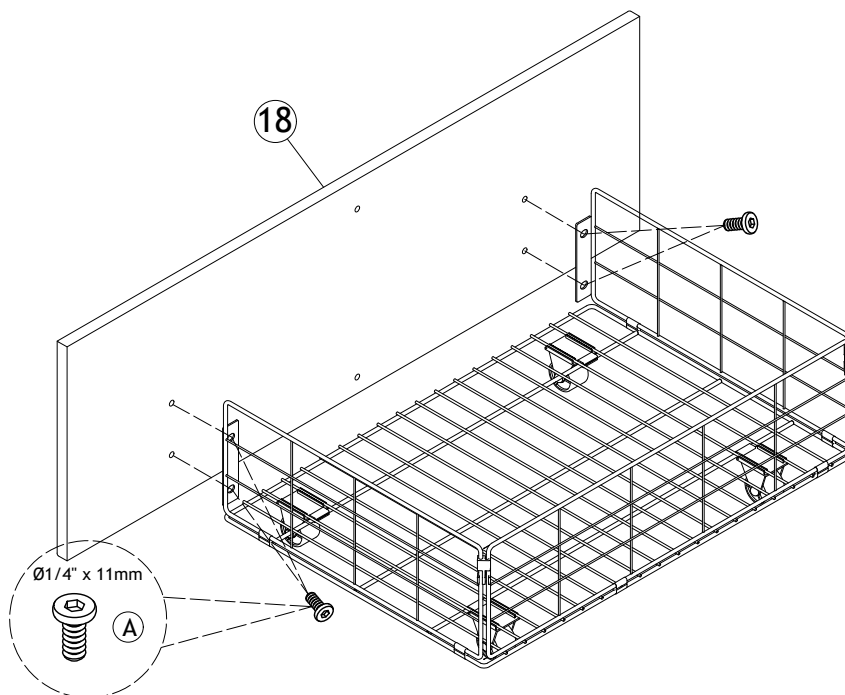
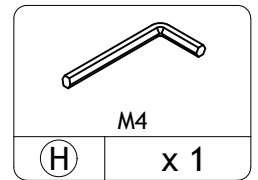
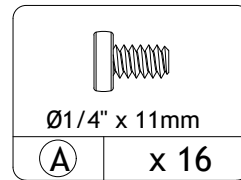

x 4

# STEP 23

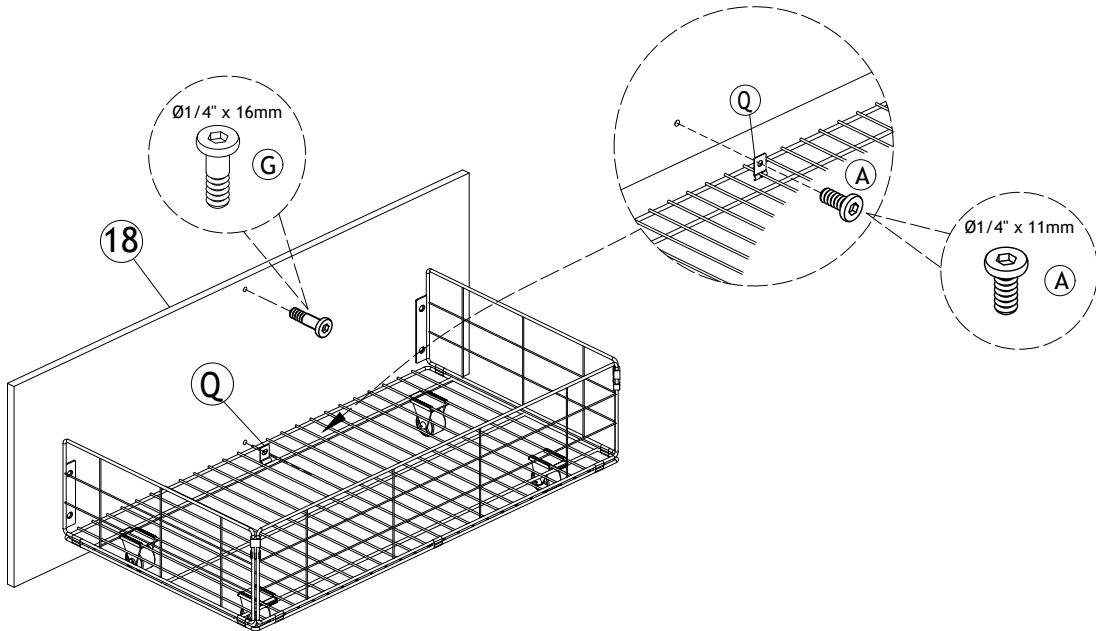
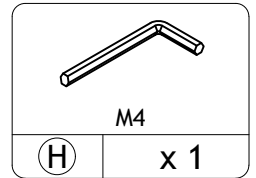
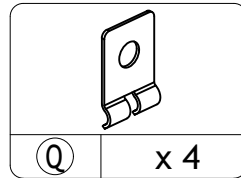
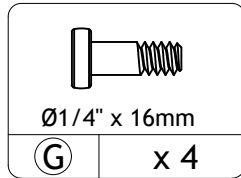
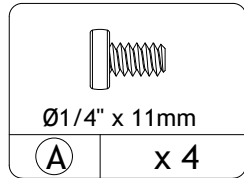

# x 4

# STEP 24

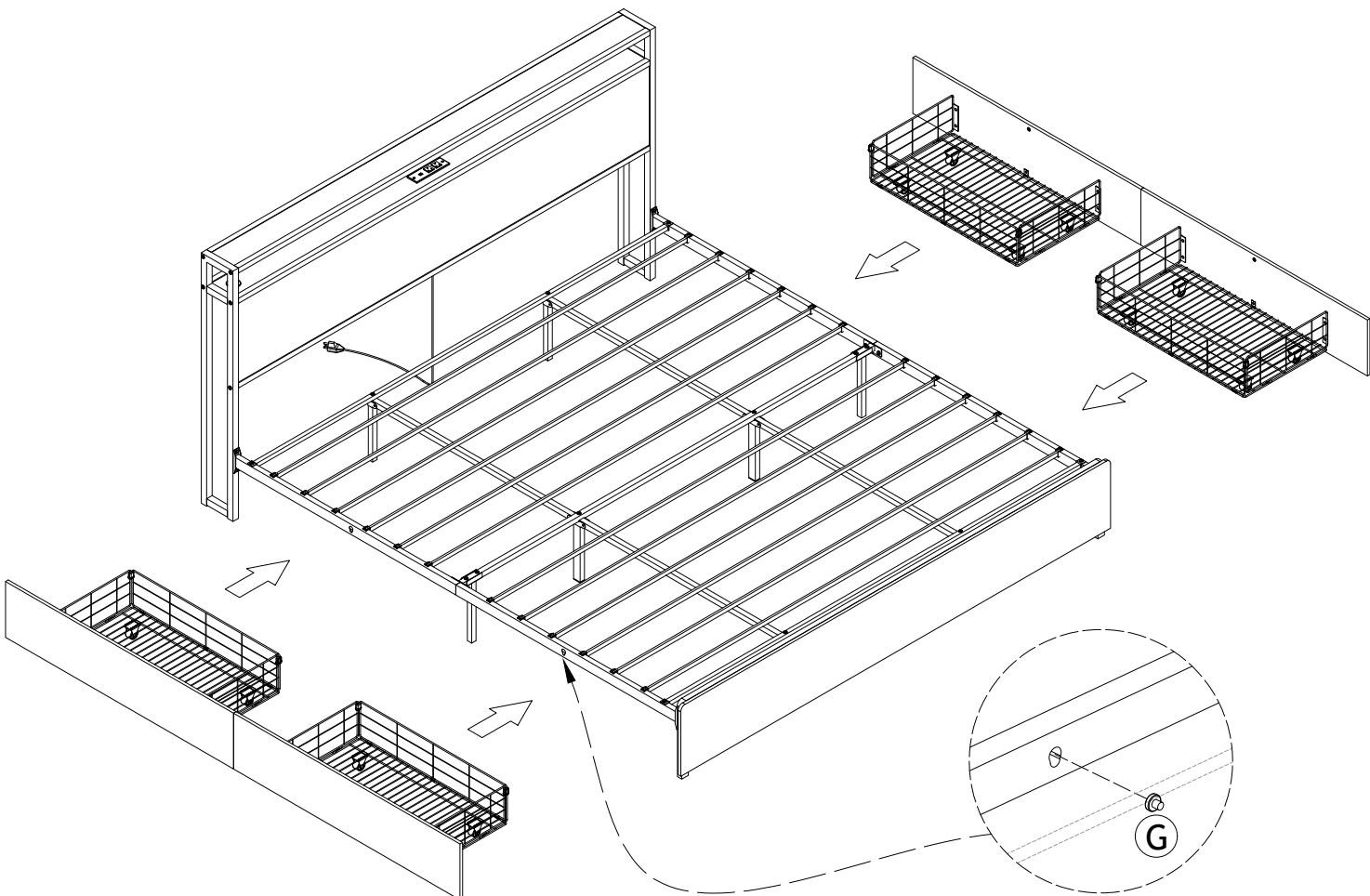

# STEP 25

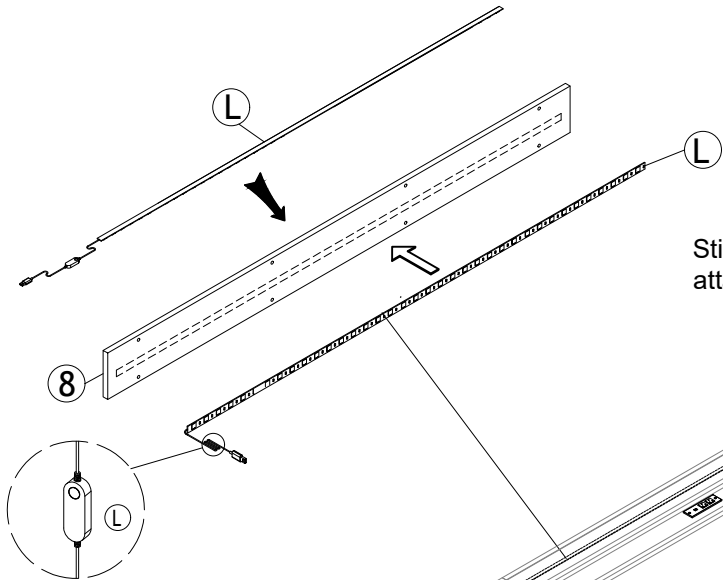
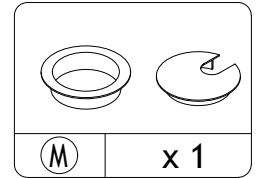
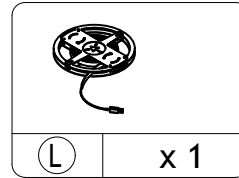

Stick LED strip(L) underneath board(8), attach the LED strip to the edges.

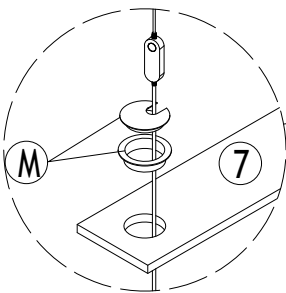

The LED switch is free to put onto or hidden underneath the board ⑦.

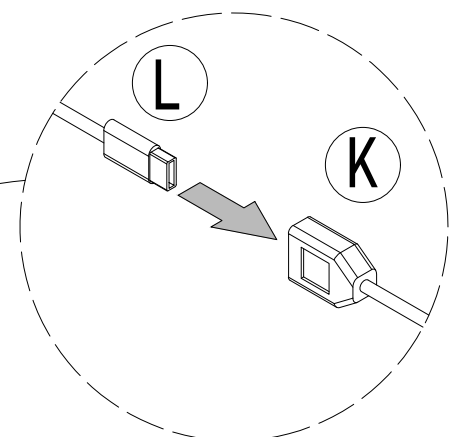
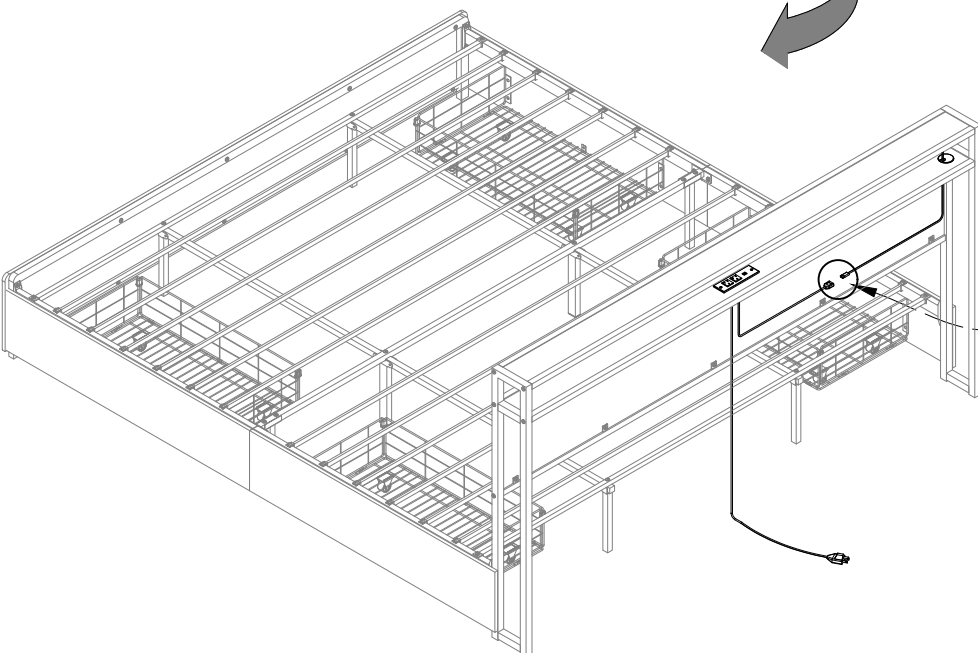
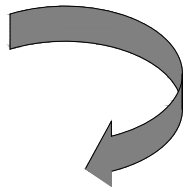
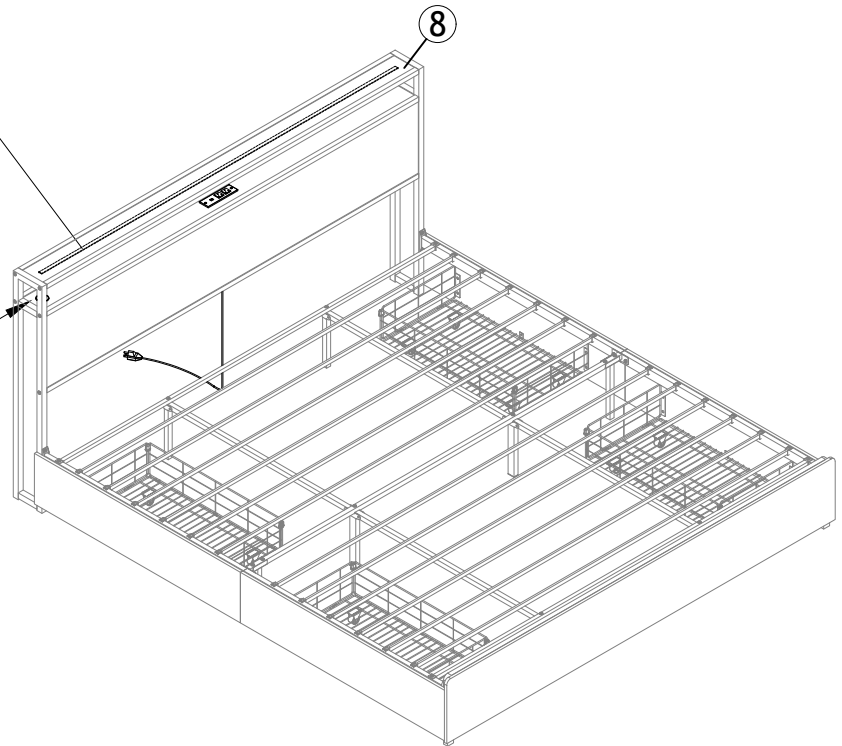



## General Guidelines

- Please read the following instruction carefully and use the product accordingly.
- Please keep this manual and hand it over when you transfer the product.
- This summary may not include every detail of all variations and considered steps. Please contact us when further information and help are needed.

## Notes

- The product is intended for indoor use only. The product must be assembled and used in accordance with the provisions of the manual. Personal injury and/or damage to product may occur if products are used outside of their intended purposes and/or if products have been changed/modified from their original design. The seller does not assume any responsibility or liability with respect to any injury/damage caused by incorrect assembly or improper use.
- Avoid long-term exposure to humid environments to prevent mildew.
- Keep the product away from fire sources and high temperatures. Do not expose the product to direct sunlight.
- Do not place any hot objects on the surface of the product.
- If there are any defective or missing parts after unpacking, please cease assembly immediately and contact us.
- Please assemble the item on a spacious surface and do not place the unwrapped product directly on the ground to avoid product damage.
- Please do not stand or sit on the wooden boards.
- Please wear gloves during the assembly and/or disassembly process to avoid scratches from any sharp edges.
- Please match the corresponding part and fitting based on the part number in the manual.
- If the part does not match with the fitting, please check the piece as specified in this manual.
- During assembly, first loosely align all screws with the corresponding pre-drilled holes and then tighten the screws one by one.
- Periodically inspect screw tightness while the product is in use. If necessary, retighten to ensure structural integrity.
- If you accidentally spill water or another liquid on the surface, immediately wipe clean with a dry towel.
- Please keep the product away from sharp, pointed objects and corrosive substances to prevent product damage.
- Please place this item on level, solid ground during use.

## Warnings

- During assembly, keep all small parts out of the reach of children. It may be fatal if swallowed or inhaled.
- Children should not climb or play on the product in order to avoid tipping over the furniture and causing serious injury.
- To avoid the potential dangers of suffocation, please keep all parts and packaging (film, plastic bags, foam, etc.) away from babies and children.
- Keep sharp objects and corrosive items away from the product to avoid any damage or injury.
- Do not shake or move violently during use to avoid tipping over the product.