

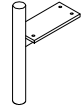

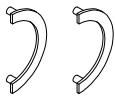



# ASSEMBLY INSTRUCTION

## PARTS

S NO.	DESCRIPTION		QTY.
A			1 pc
B	B1		4 pcs
	B2		
	B3		
	B4		
C	C1		2 pcs
	C2		

## HARDWARE

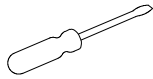
S NO.	DESCRIPTION		QTY.
I		<b>BOLT</b> (SIZE: 6X16 MM)	16 pcs
II		<b>WASHER</b> (SIZE: 6X16 MM)	16 pcs
III		<b>SPRING WASHER</b> (SIZE: 6X16 MM)	16 pcs
IV		<b>SCREW</b> (SIZE: 6X35 MM)	4 pcs
V		<b>ALLEN KEY</b> (SIZE: 4X67 MM)	1 pc
VI		<b>SCREW DRIVER</b> (SIZE: 6X170 MM)	1 pc

STEP 1:

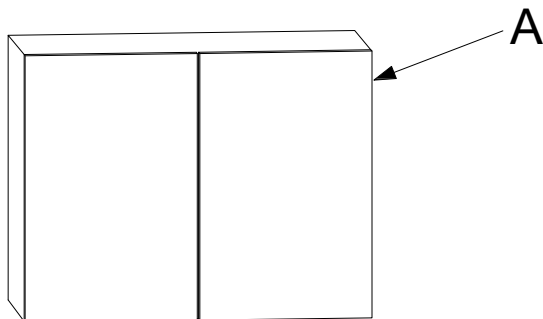

STEP 2: Put the sideboard upside down. Now tighten the bolt for all the four legs.

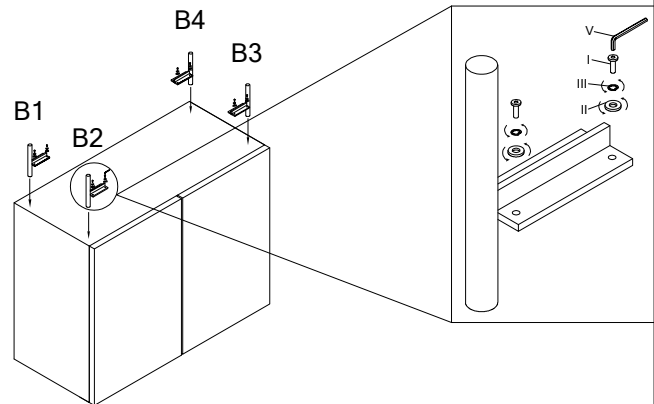

STEP 3: Once Legs get tighten, upright the Sideboard. Now, Screw the handle as shown in the image.

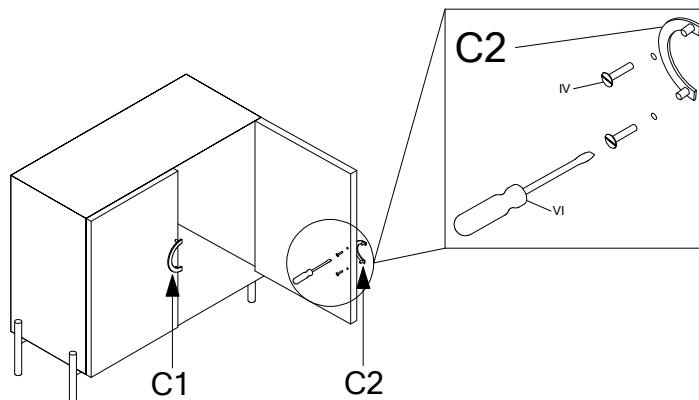

STEP 4: Assembly complete.

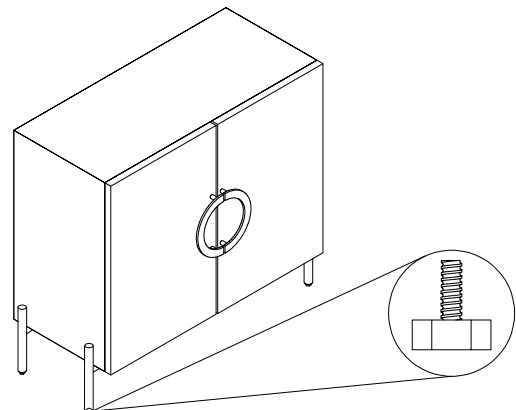

NOTE: Levellers are provided at bottom to balance the product on uneven surface.