

4'6" BED

ASSEMBLY INSTRUCTIONS

Read this instruction carefully. See hardware and furniture part list for guidance. Be sure all parts are complete, before you assemble. Place all wooden furniture parts on a clean and flat soft surface to prevent from being scratched. Follow the figure to start assembling.

CAUTIONS : 1. Do not FULLY - TIGHTEN the nut or nut bolt until all nut or bolt is ready assembled.
2. Do not OVER - TIGHTEN the nut or bolt to avoid causing damages to the thread.
3. Keep all hardware parts out of reach of children.

NOTE : THE LIST AND QUANTITY SHOWN ARE FOR 1 UNIT ASSEMBLY.

PART LIST		
ITEM	DESCRIPTION	QTY
A	HEADBOARD	1 PC
B	FOOTBOARD	1 PC
C	SIDE RAIL	2 PCS
D	CENTER RAIL	1 PC
E	CENTER SUPPORT	2 PCS
F	CENTER SUPPORT LEG	2 PCS
G	BED SLAT	24 PCS
H	BED LEG	4 PCS

PART LIST		
ITEM	DESCRIPTION	QTY
1	JCBB BOLT M8 x 40mm	8 PCS
2	WOOD SCREW M3.5 x 16mm	8 PCS
3	M5 ALLEN KEY	1 PC
4	BED SLAT SIDE FITTER	24 PCS
5	BED SLAT CENTER FITTER	12 PCS
6	WOOD SCREW M4 x 25mm	8 PCS

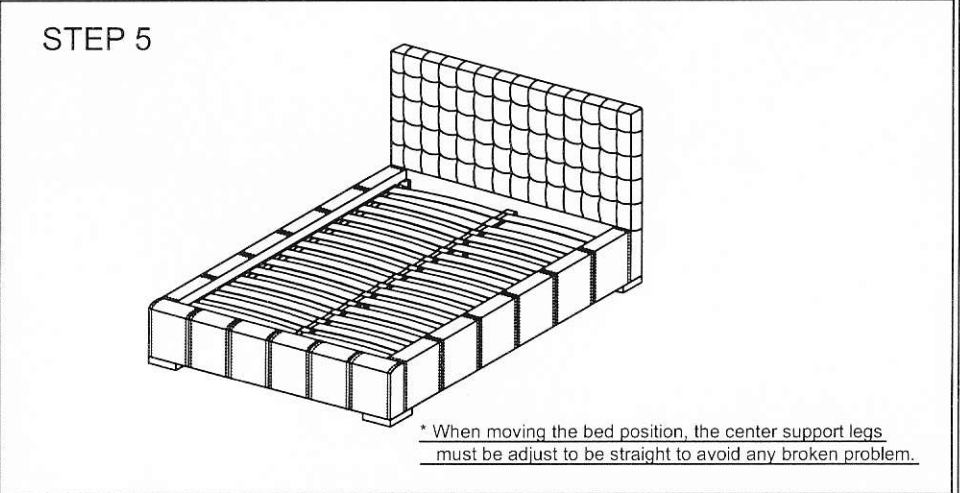
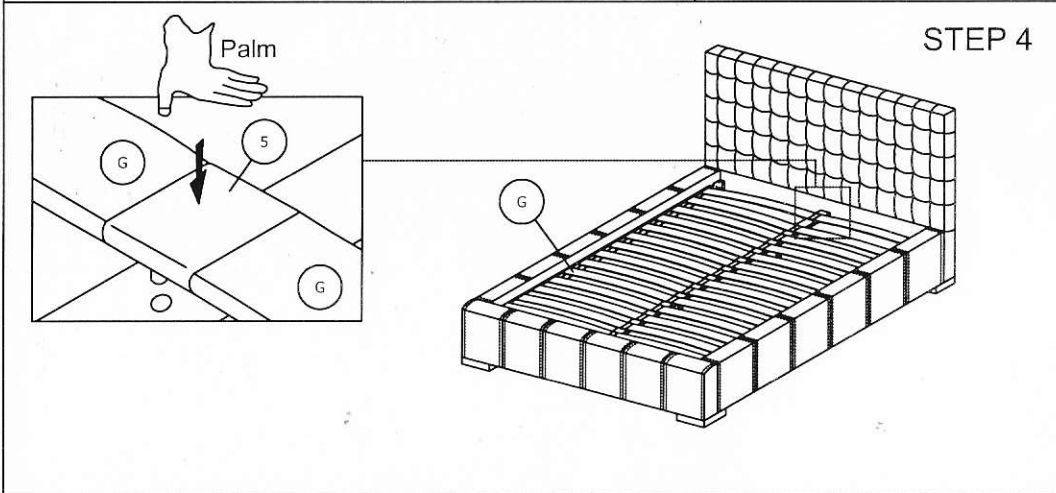
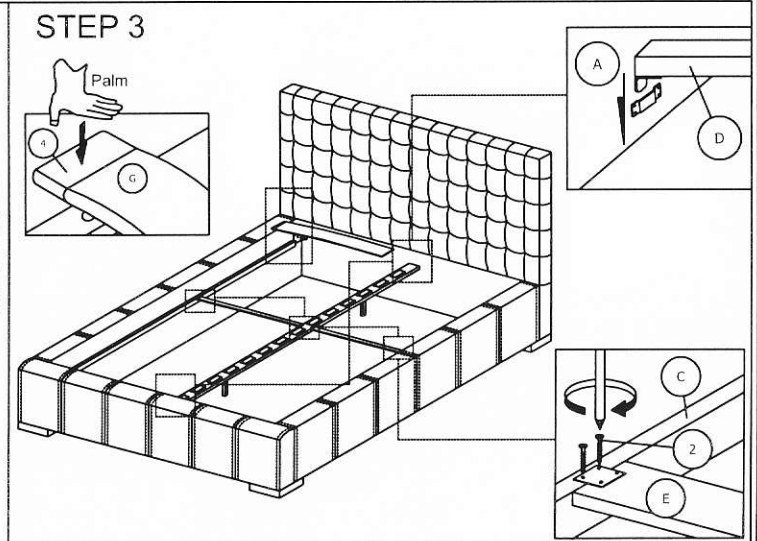
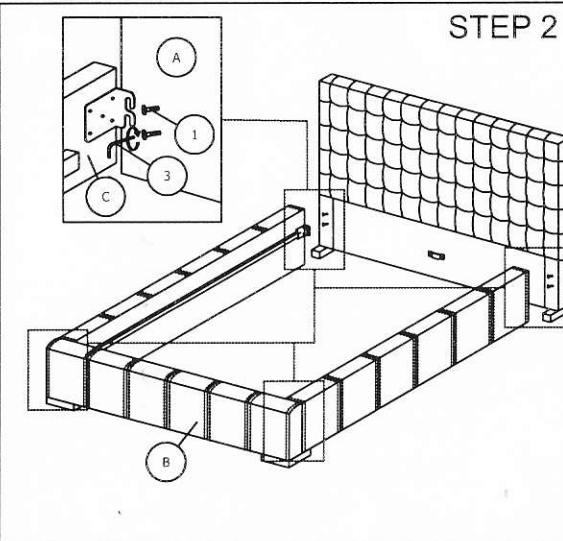
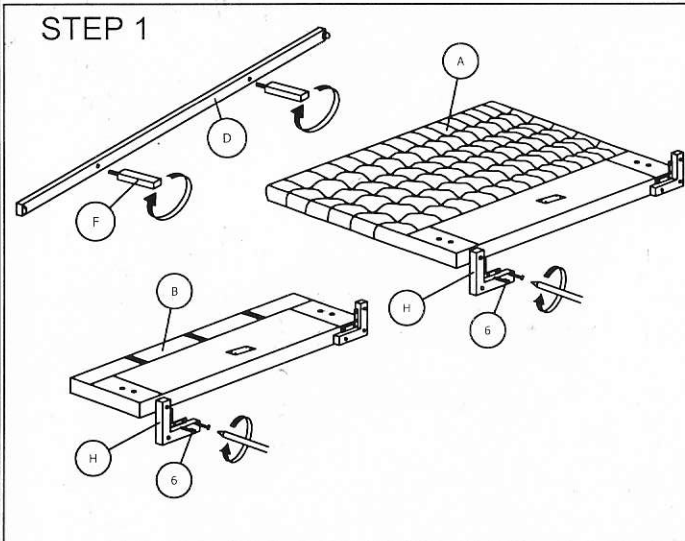

* When moving the bed position, the center support legs must be adjust to be straight to avoid any broken problem.