





ASSEMBLY INSTRUCTIONS

CONSOLE

Parts List			
Item	Figure	Q'ty	Description
(1)		1PC	Table Top
(2)		2PCS	Bottom Shelves
(3)		4PCS	Legs
(4)		0PCS	∅ 1/4" Adj Glides

Hardware Kit				
Item	Figure	Spec.	Q'ty	Description
A		1/4"dia*3/4"	24 pcs	Allen Bolts
B		1/4"dia	24 pcs	Lock Washers
C		1/4" I.D.*19mm O.D.	24 pcs	Flat Washers
D		4mm*2.5"	1 pc	Allen Wrench

Please note: The following steps may need 2 persons to complete it.

STEP 1:

Please carefully place table top (Item 1) upside down on a soft clean surface. Carefully turn leg (Item 3) upside down and attach 3 legs to the table top with an Allen Bolt (A), Lock Washer (B) Flat Washer (C) loosely tighten with provided Allen Wrench (D).

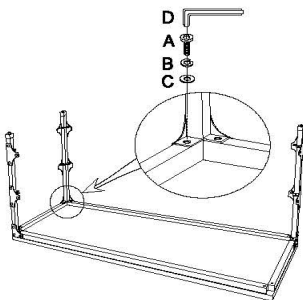

STEP 2:

Carefully turn one Middle Shelf (Item 2) upside down and gently slide it in-between the 3 legs ; attach the shelf to the leg with an Allen Bolt (A), Lock Washer (B), Flat Washer (C), loosely tighten with provided Allen Wrench (D). Repeat the same process for the other Shelf.

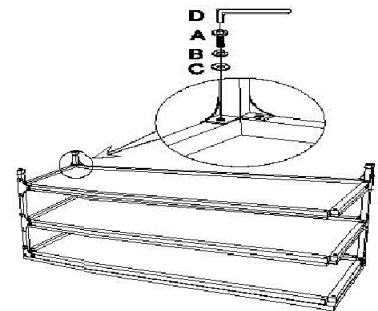
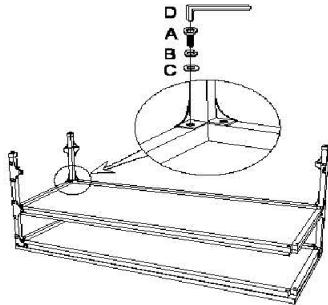

STEP 3:

Adjust all parts to the appropriate positions, attach the fourth leg and then tighten all Allen Bolts.

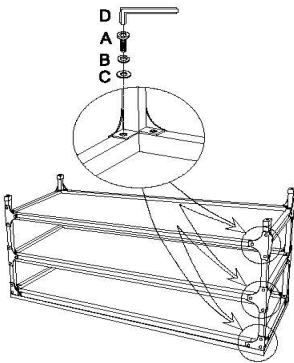

STEP 4:

Carefully turn the assembled table to the upright position.

