

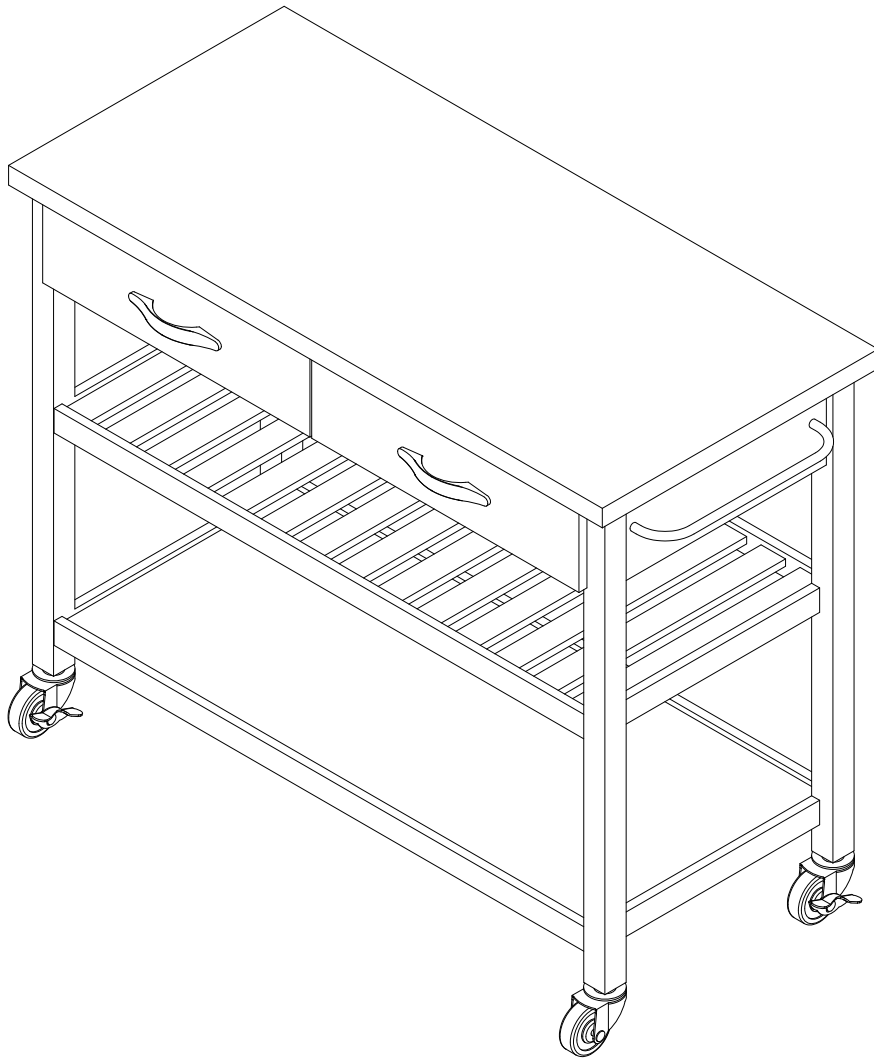

ASSEMBLY INSTRUCTIONS

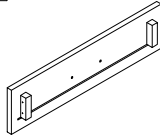

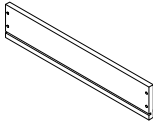

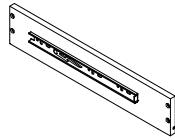
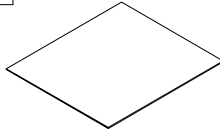
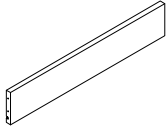
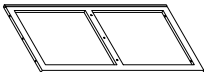
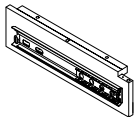
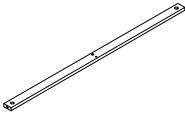
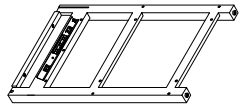
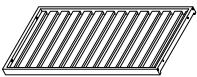

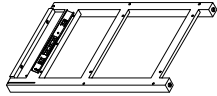
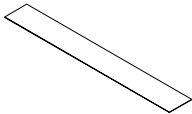
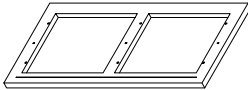

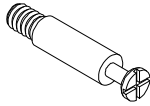

Kitchen Cart

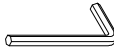

PART LIST

<p>A</p> 	<p>B</p> 	<p>C</p> 	<p>D</p> 	<p>E</p> 
<p>Drawer Front Panel 2 PCS</p>	<p>Drawer Left Side Panel 2 PCS</p>	<p>Drawer Right Side Panel 2 PCS</p>	<p>Drawer Bottom Panel 2 PCS</p>	<p>Drawer Back Panel 2 PCS</p>
<p>F</p> 	<p>G</p> 	<p>H</p> 	<p>I</p> 	<p>J</p> 
<p>Upper Rack 1 PC</p>	<p>Partition Panel 1 PC</p>	<p>Crossbar 1 PC</p>	<p>Left Side Panel 1 PC</p>	<p>Shelf Panel 1 PC</p>
<p>K</p> 	<p>L</p> 	<p>M</p> 	<p>N</p> 	
<p>Bottom Panel 1 PC</p>	<p>Right Side Panel 1 PC</p>	<p>Back Panel 1 PC</p>	<p>Top Panel 1 PC</p>	

HARDWARE LIST

<p>#1</p> 	<p>#2</p> 	<p>#3</p>  <p>Ø8*30</p>	<p>#4</p>  <p>Ø4*25</p>	<p>#5</p> 
<p>Camlock Bolt 2 PCS</p>	<p>Camlock 2 PCS</p>	<p>Wood Dowel 19 PCS</p>	<p>Flat Head Screw 16 PCS</p>	<p>Handle 2 PCS</p>
<p>#6</p>  <p>M4*16</p>	<p>#7</p>  <p>Ø1/4×1"</p>	<p>#8</p> 	<p>#9</p> 	<p>#10</p> 
<p>Small Bolt 4 PCS</p>	<p>Shot Bolt 22 PCS</p>	<p>Allen Wrench 1 PC</p>	<p>Towel Bar 1 PC</p>	<p>Caster 2 PCS</p>
<p>#11</p> 	<p>#12</p>  <p>Ø4*32</p>			
<p>Locking Caster 2 PCS</p>	<p>Flat Head Screw 1 PC</p>			

ADDITIONAL TOOLS (Not Provided)

Note: It is not recommended to use power tools during assembly.

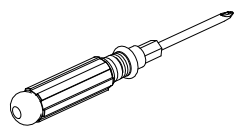

Phillips Head Screwdriver

Note: Wood dowels are intended for alignment. Additional clearance between wood dowel and pre-drilled hole is intentional for ease of assembly.

Assemble this item on a soft pad if you can

Step 1. Attach drawer side panels (parts B & C) to drawer front panel (part A) using flat head screws (part #4) and phillips head screwdriver. Slide drawer bottom panel (part D) into the assembled unit (parts A, B & C). Attach drawer back panel (part E) to drawer side panels (parts B & C) using flat head screws (part #4) and phillips head screwdriver. Attach handles (part #5) to drawer front panel (part A) using small bolts (part #6) and phillips head screwdriver.

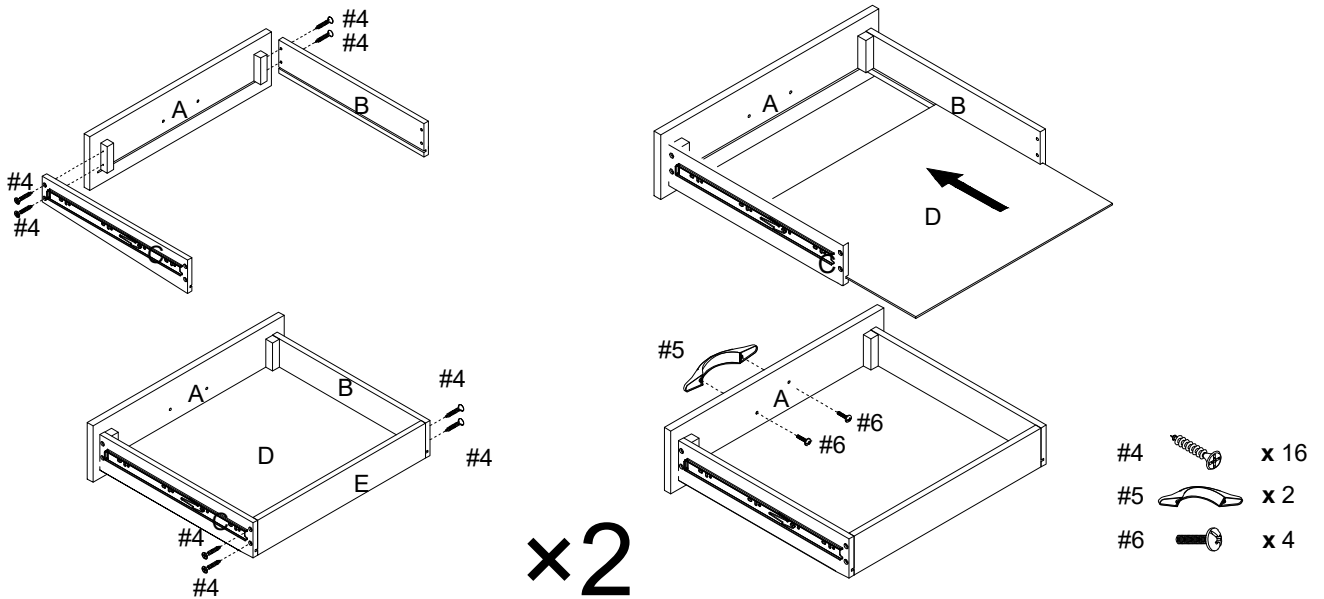

Step 2. Attach partition panel (part G) to upper rack (part F) using short bolts (part #7) and allen wrench (part #8).

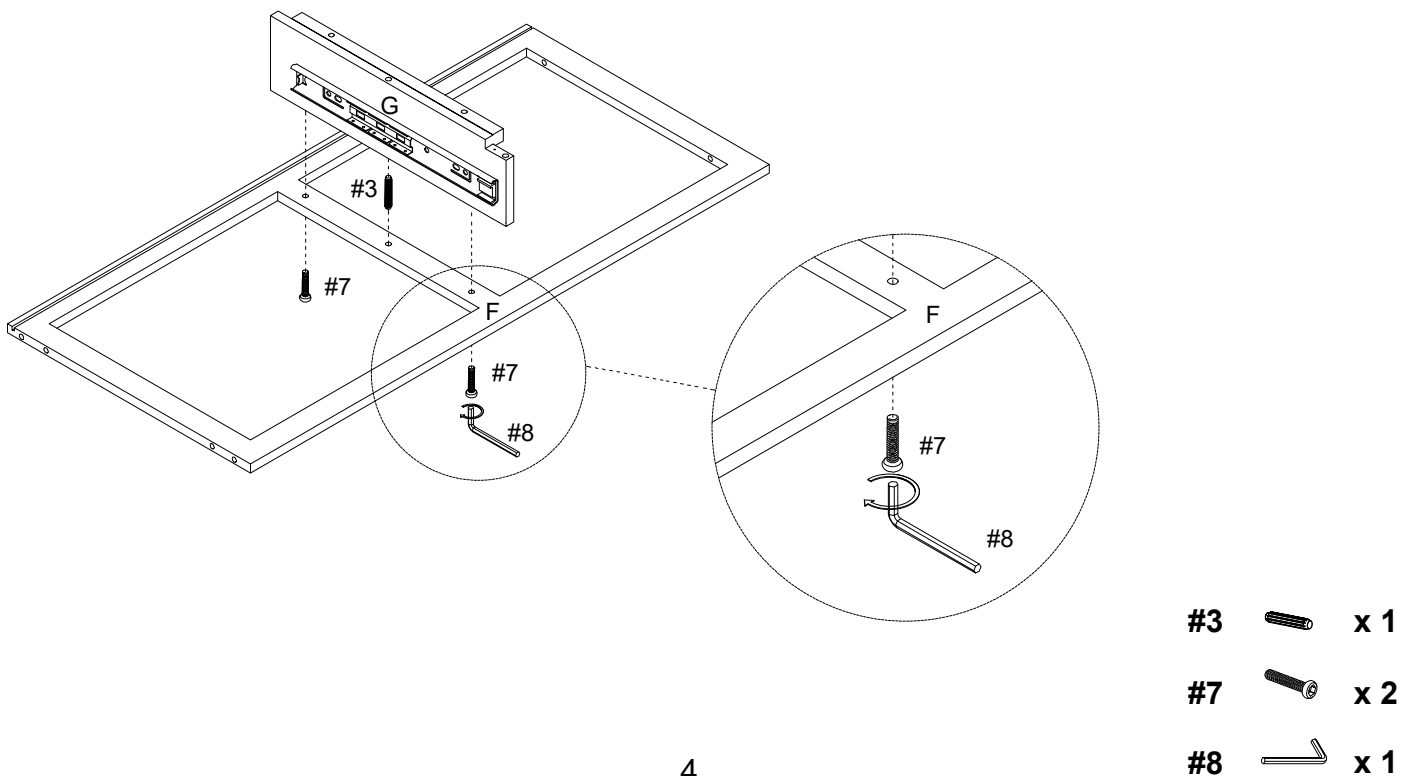



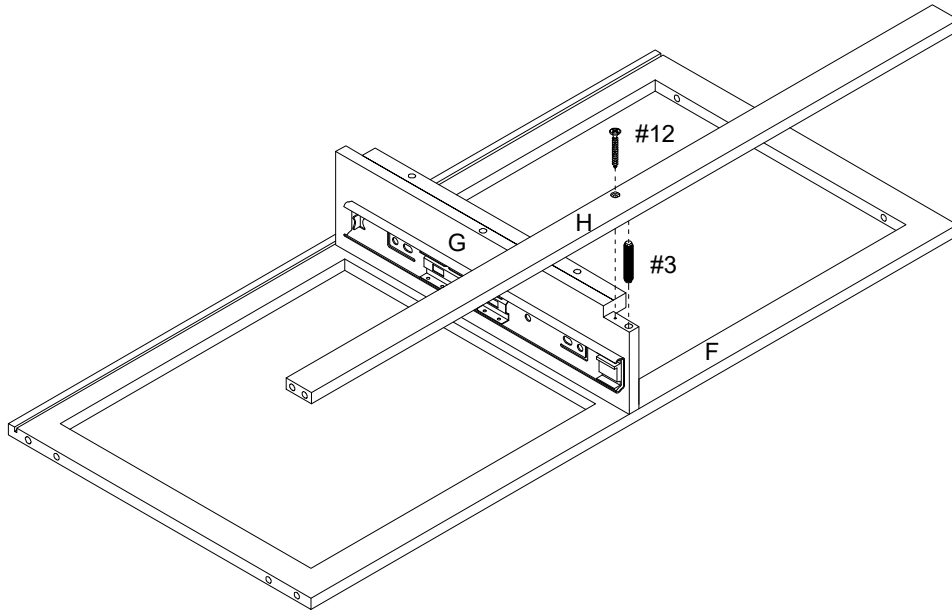



Step 3. Attach crossbar (part H) to partition panel (part G) using wood dowels (part #3), flat head screws (part #4) and phillips head screwdriver.

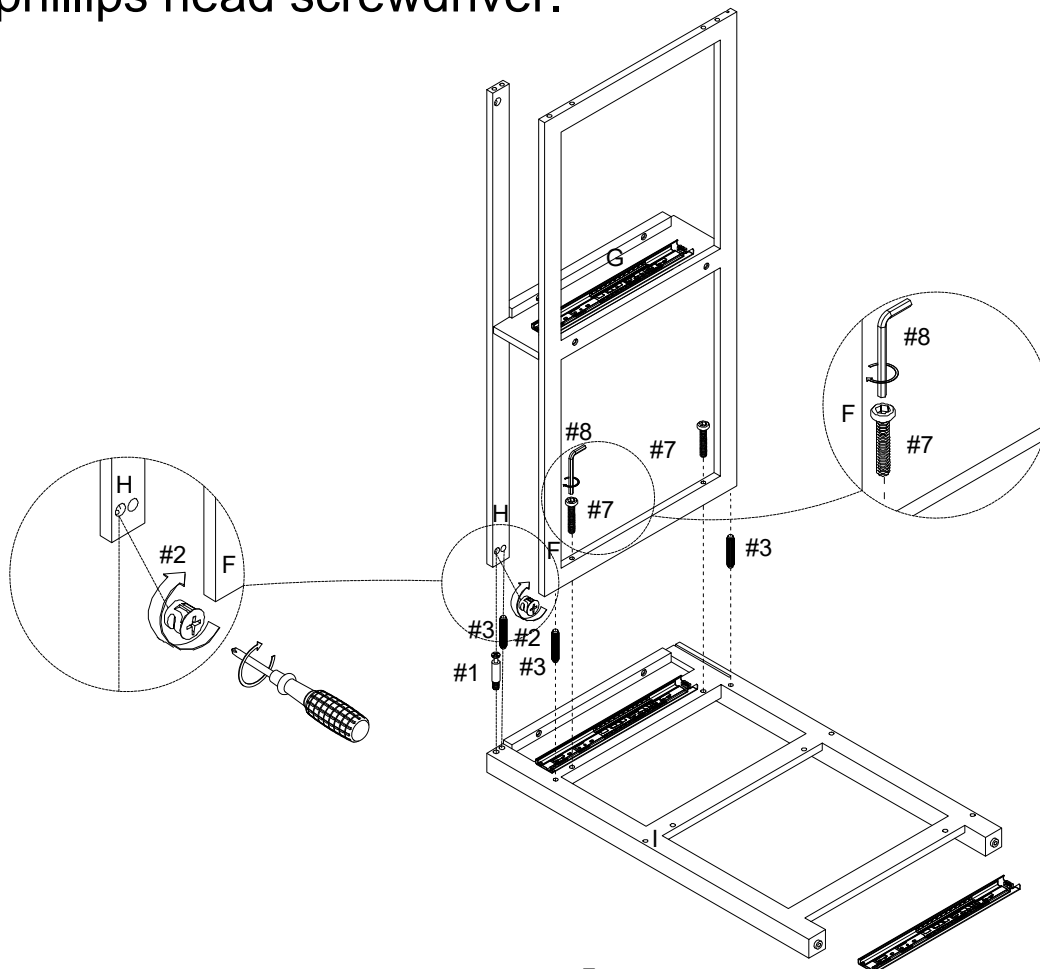

- #3  x 1
- #12  x 1

Step 4. Attach left side panel (part I) to assembled unit (part F & H) using cambolts (part #1), camlocks (part #2), wood dowels (part #3), long bolts (part #9), allen wrench (part #8) and phillips head screwdriver.



- #1  x 1
- #2  x 1
- #3  x 3
- #7  x 2
- #8  x 1

Step 5. Attach shelf (part J) to left side panel (part I) using wood dowels (part #3), shot bolts (part #7) and allen wrench (part #8).

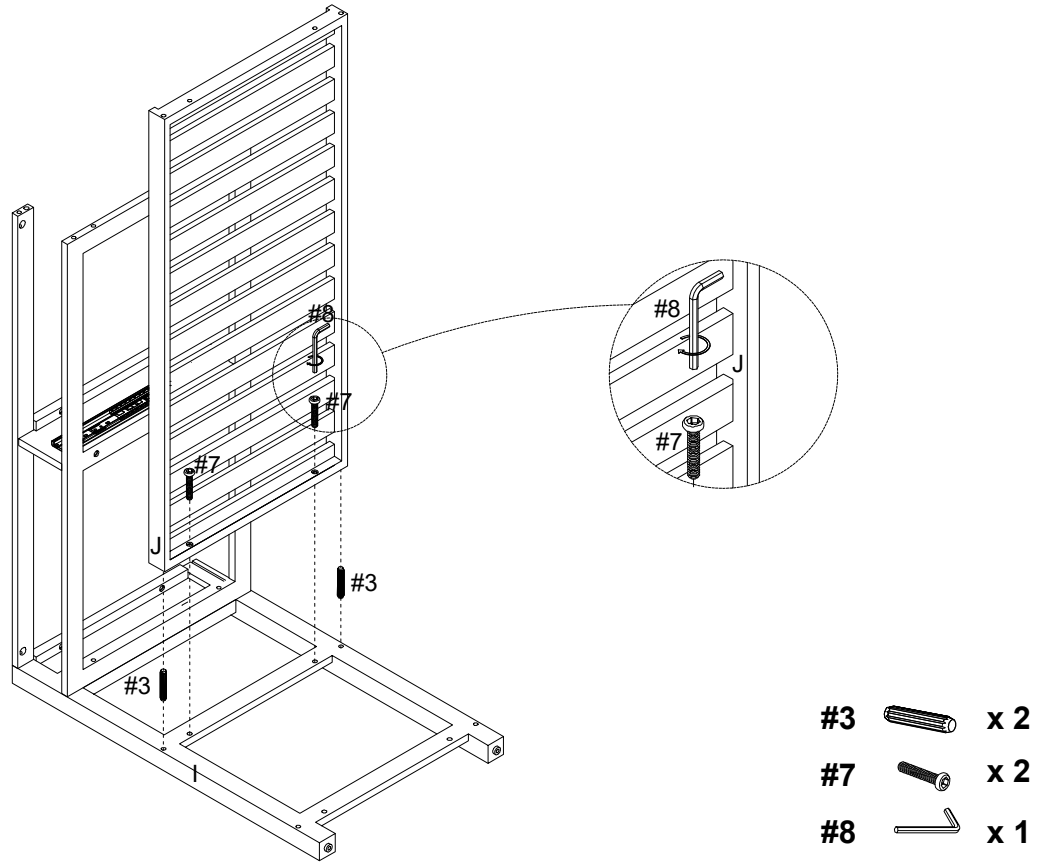

Step 6. Attach bottom panel (part K) to left side panel (part I) using wood dowels (part #3), shot bolts (part #7) and allen wrench (part #8).

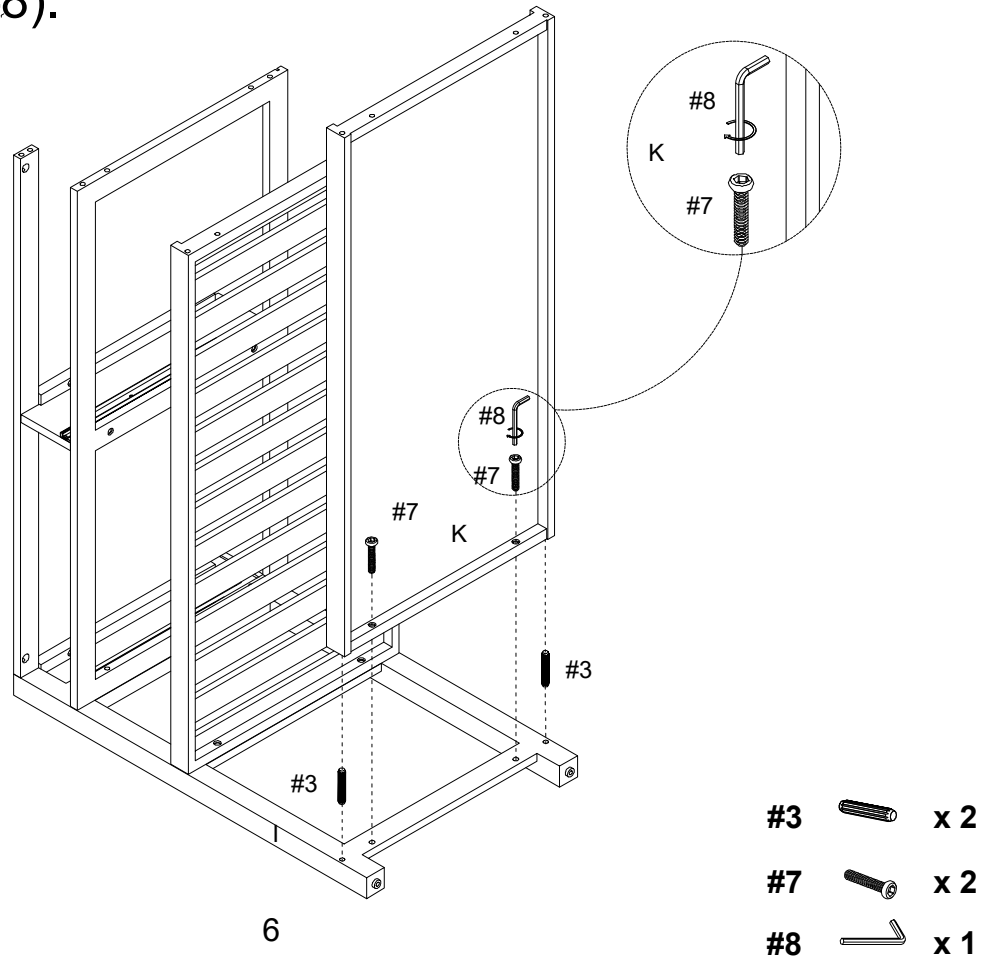

Step 7. Attach right side panel (part I) to assembled unit (part F, H, J & K) using cambolts (part #1), camlocks (part #2), wood dowels (part #3), short bolts (part #7), long bolts (part #9), allen wrench (part #8) and phillips head screwdriver.

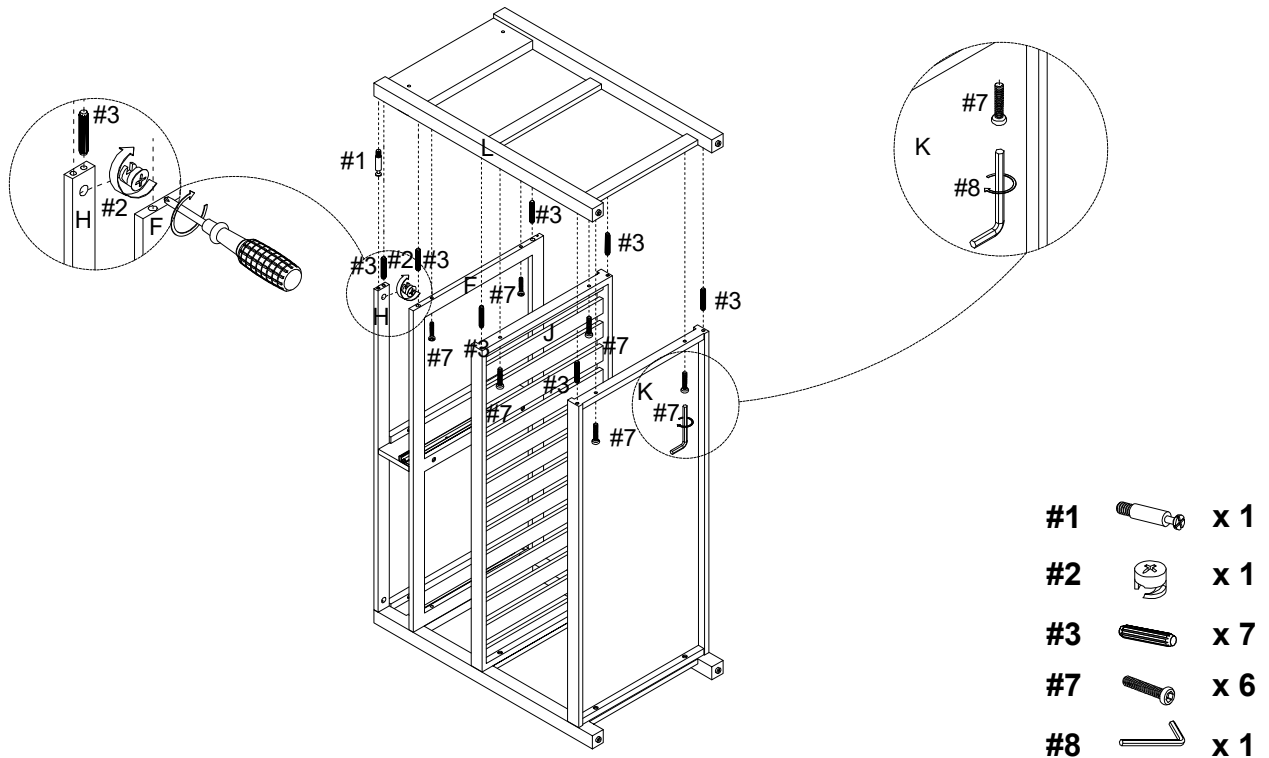

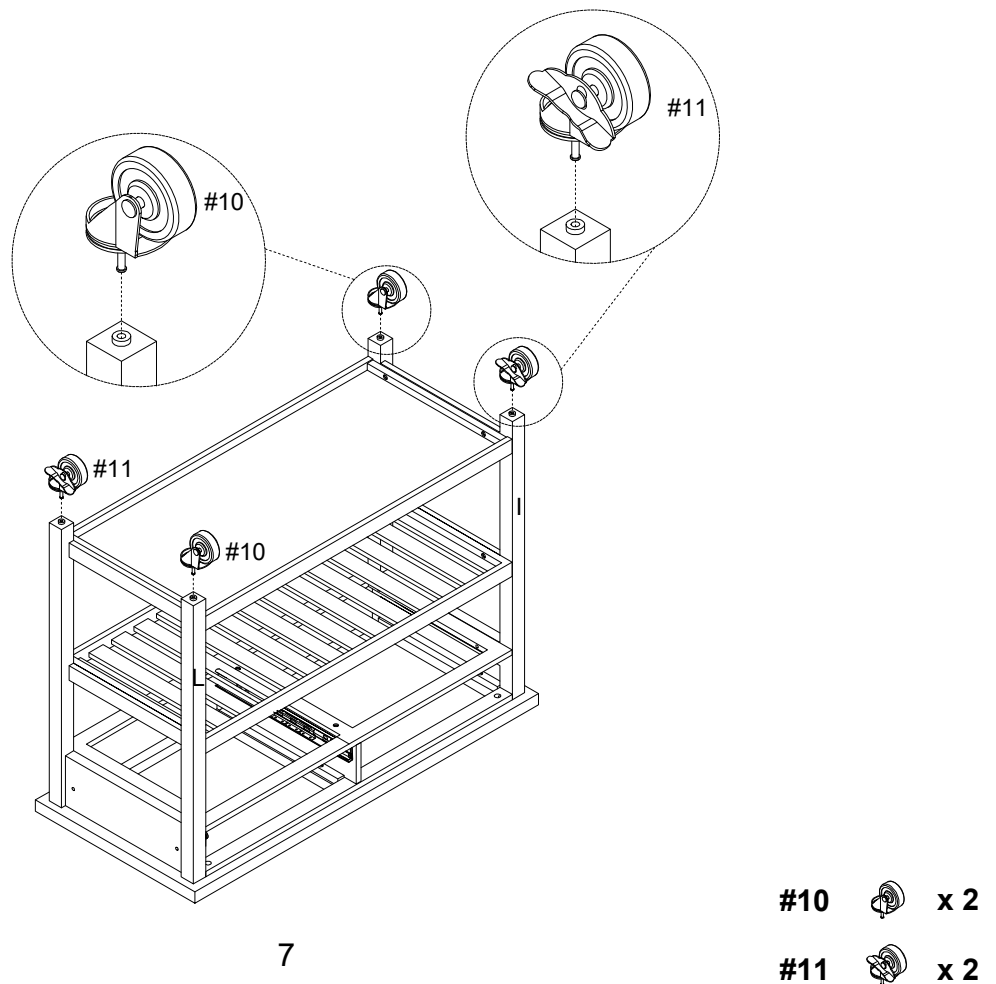

Step 8. Press caster (part #10) and locking caster (part #11) into holes of legs as show.

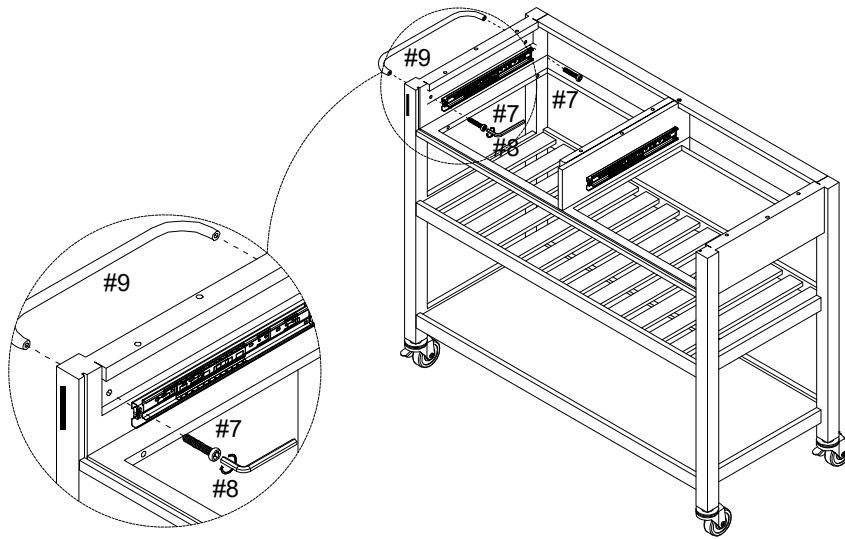

Step 9. Carefully turn unit upright. Attach towel bar (part #13) to left side panel (part I) using short bolts (part #7) and allen wrench (part #8).



- #7  x 2
- #8  x 1
- #9  x 1

Step 10. Slide back panel (part M) into the assembled unit (parts F, I & L).

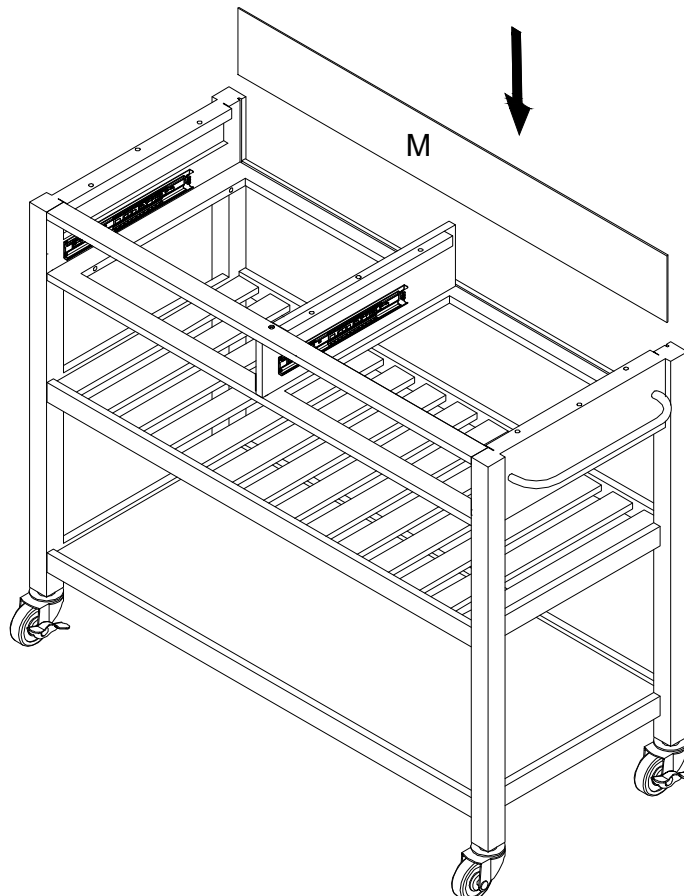

Step 11. Attach top panel (part N) to assembled unit (parts F, G, I, H & M) using wood dowels (part #3), short bolts(part #7) and allen wrench (part #8).

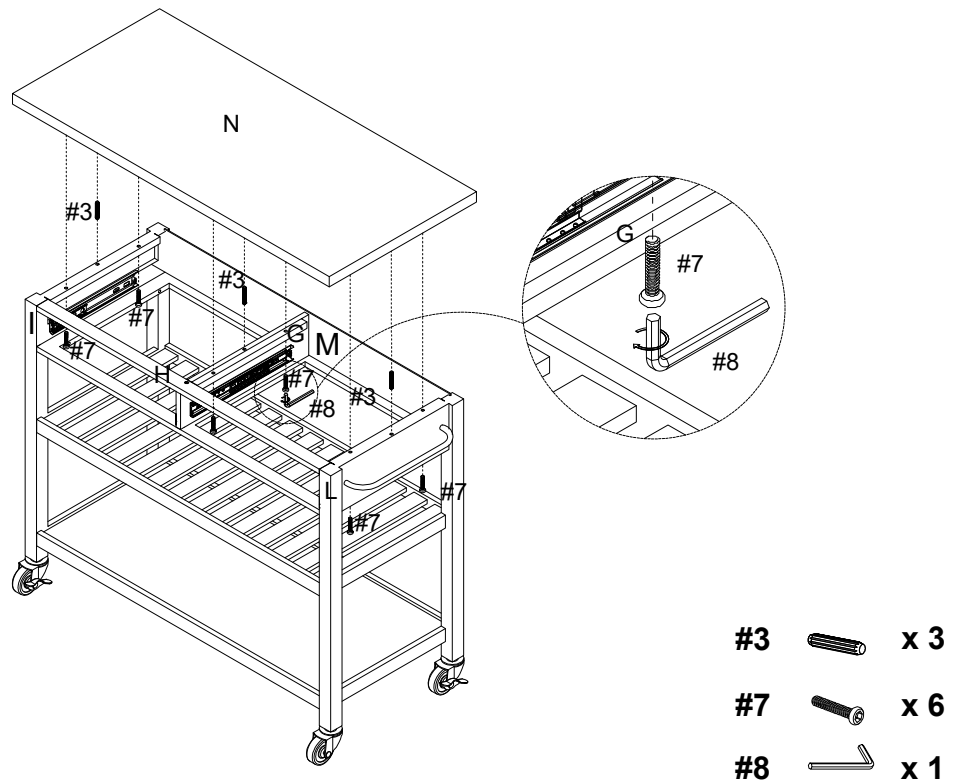

Step 12. Slide assembled drawers into place.

