

BATTLESTATION GAMING DESK

ASSEMBLY INSTRUCTIONS

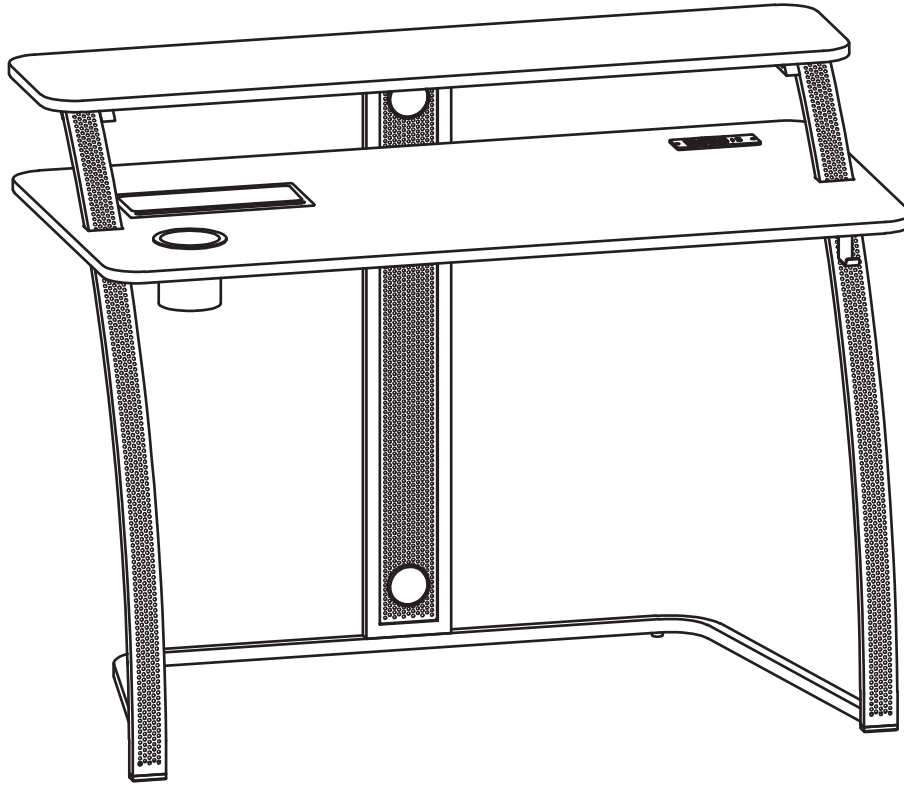

WARNING

1. Do not use this product unless all bolts, screws, and knobs are securely tightened.
2. Check that all bolts, screws, and knobs are tight every three months or as needed.
3. Dispose of packing material properly. Do not use plastic cover as head covering as it may cause suffocation.
4. Do not use product as stepladder.
5. Use product for its intended purpose only.
6. Use mild detergent only for cleaning.

OSP FURNITURE LIMITED PRODUCT WARRANTY

Design Lab Products



- 3 years on gaming desks and chairs
- Upholstery is not warranted against routine scratching and scuffing

*All warranties are limited to the original purchaser for normal commercial usage defined as a standard forty hour work week by persons weighing 250 lbs. or less. This warranty will not cover labor, freight or damage from misuse, abuse, negligence, alteration, accident, vandalism, rusting, acts of nature or any other event beyond the control of Office Star Products. The warranty does not cover cosmetic damage that may result from normal use. Liability for incidental or consequential damages is excluded. The user assumes all risk of injury resulting from use of this product. When usage is more than 40 hours per week, a two year warranty on all parts applies. Fabric and foam is warranted for one year. This warranty gives you specific legal rights, and you may also have other rights which vary from state to state.

It is the customer's responsibility to prepay freight on any components returned to the factory. Return freight on components covered by warranty will be paid by Office Star Products.



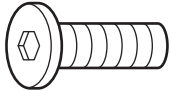
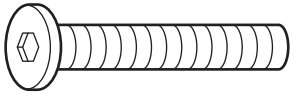
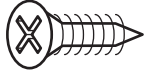







Our quality standards are among the highest in the industry. Sometimes, no matter how hard we try, there are times when parts are damaged or missing. Our Parts Department will do everything possible to promptly remedy the problem. Contact us via e-mail parts.department@officestar.net by Fax 1-909-930-5629, or toll free parts number 1-800-950-7262, Monday through Friday 8:00 a.m. - 3:30 p.m. Pacific Time.

HARDWARE LIST

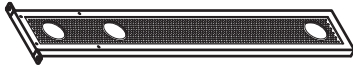
NO	DRAWING	DESCRIPTION	SIZE	QUANTITY
A		Allen Bolt	1/4" x 12mm	21 PCS + 2 Extra
B		Allen Bolt	1/4" x 30mm	20 PCS + 2 Extra
C		Flat Head Screw	#4 x 15mm	2 PCS
D		Allen Wrench	4mm	1 PC

Phillips screwdriver also needed for assembly (not provided)

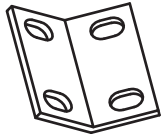
PARTS

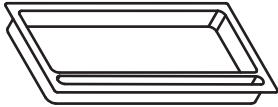
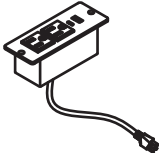
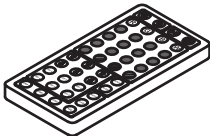
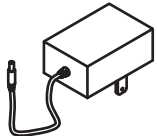
		
(1) Top Panel (1 PC)	(2) Desktop (1 PC)	(3) Top Metal Frame (1 PC)
		
(4) Middle Metal Frame (1 PC)	(5) Rear Metal Frame (1 PC)	(6) Bottom Metal Frame (1 PC)
		
(7) Left Front Leg (1 PC)	(8) Right Front Leg (1 PC)	(9) Bracket (2 PCS)
		
(10) Accessory Hook (1 PC)	(11) Plastic Cup Holder (1 PC)	(12) Plastic Tray (1 PC)
		
(13) Power Outlet (1 PC)	(14) Remote (1 PC)	(15) LED Power Supply (1 PC)

BATTLESTATION GAMING DESK

ASSEMBLY INSTRUCTIONS

STEP 1

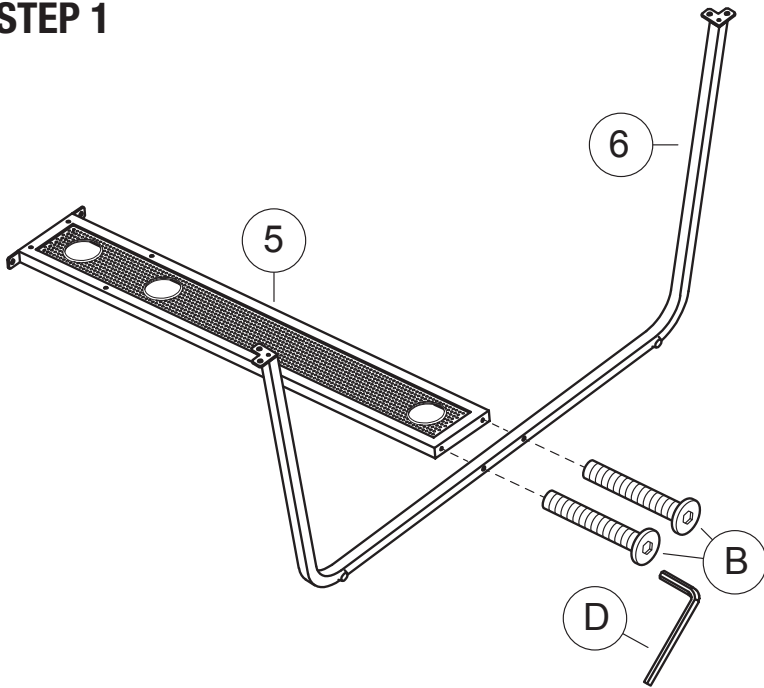

STEP 2

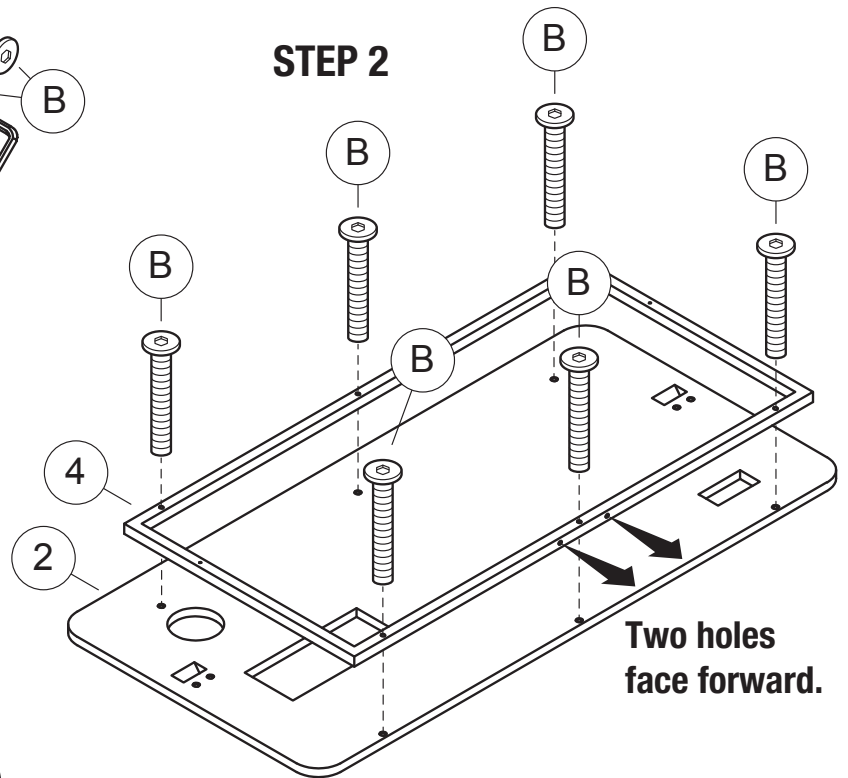

STEP 3

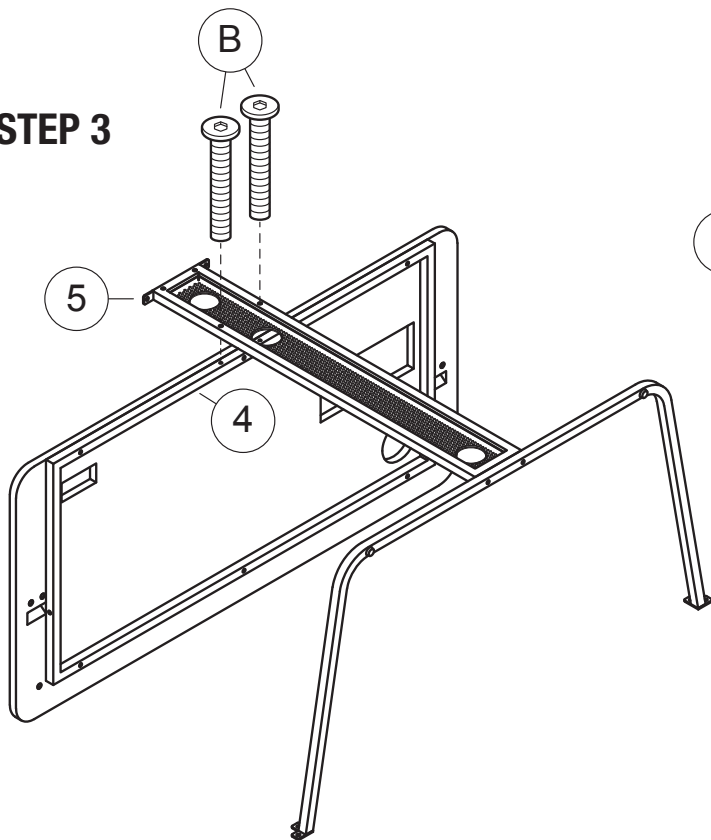

Remove all parts from carton, separate by part numbers indicated on parts list, and verify part quantities.

STEP 1 Attach Bottom Metal Frame (6) to Rear Metal Frame (5) using two Allen Bolts (B).

STEP 2 Attach Middle Metal Frame (4) to underside of Desktop (2) using six Allen Bolts (B).

STEP 3 Attach Rear Metal Frame (5) to Middle Metal Frame (4) using two Allen Bolts (B). **FULLY TIGHTEN ALL ALLEN BOLTS IN STEPS 1-3.**

BATTLESTATION GAMING DESK

ASSEMBLY INSTRUCTIONS

STEP 4

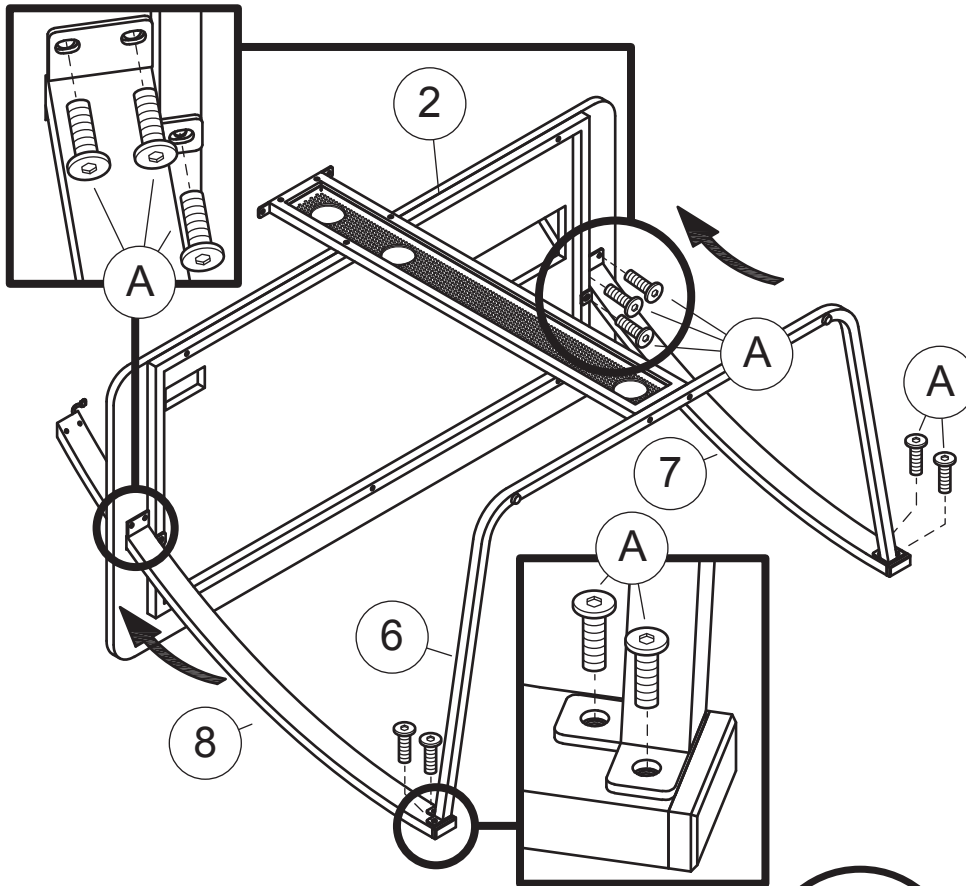

STEP 5

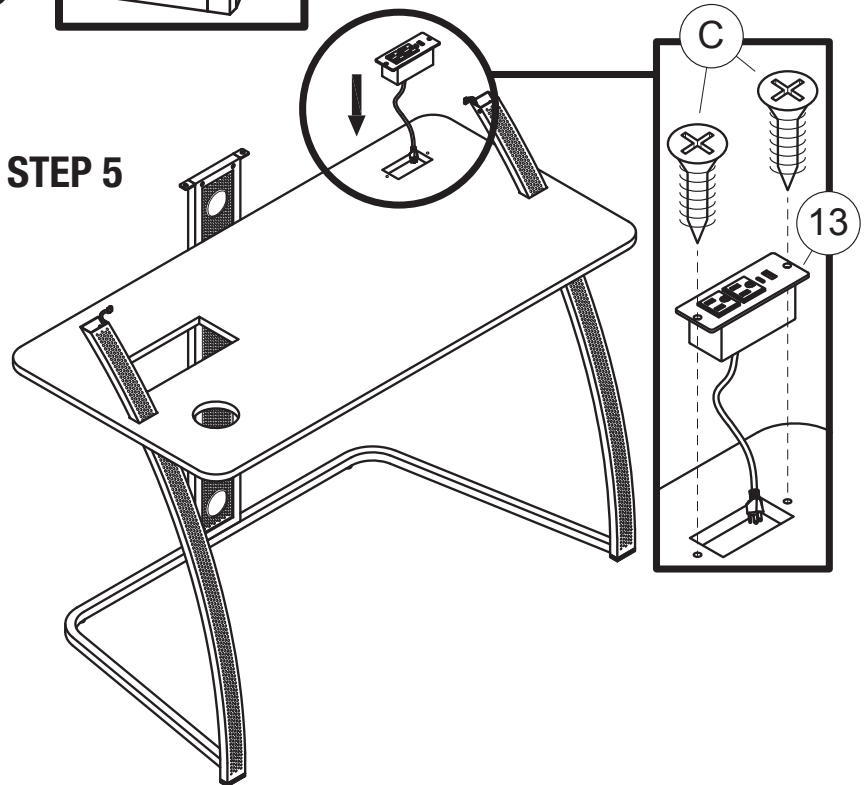

STEP 4 Slide Front Legs (7 & 8) through holes in Desktop (2) and attach using three Allen Bolts (A) on each side – see inset. Attach Bottom Metal Frame (6) to Front Legs (7 & 8) using two Allen Bolts (A) on each side. **FULLY TIGHTEN ALL ALLEN BOLTS.**

STEP 5 Attach Power Outlet (13) to Desktop using two Flat Head Screws (C).

BATTLESTATION GAMING DESK

ASSEMBLY INSTRUCTIONS

STEP 6

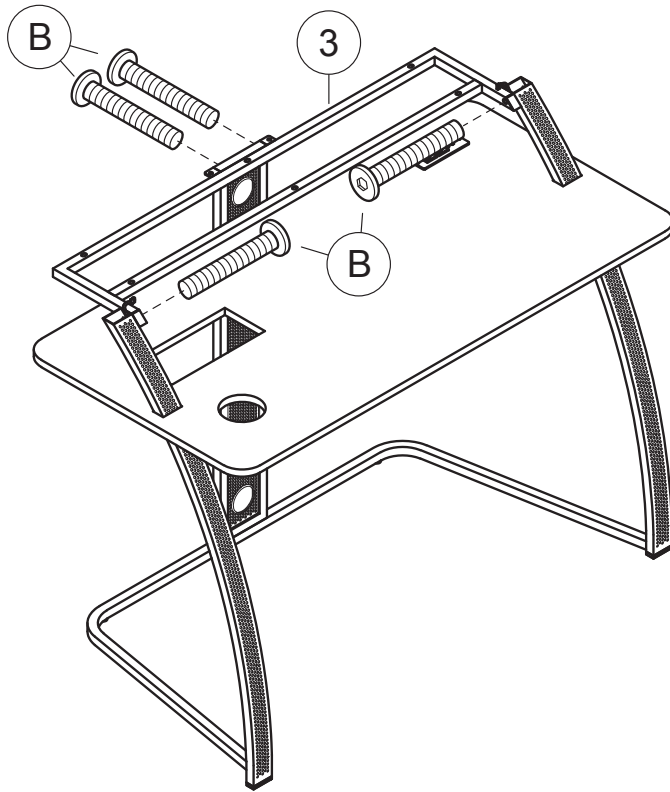

STEP 7

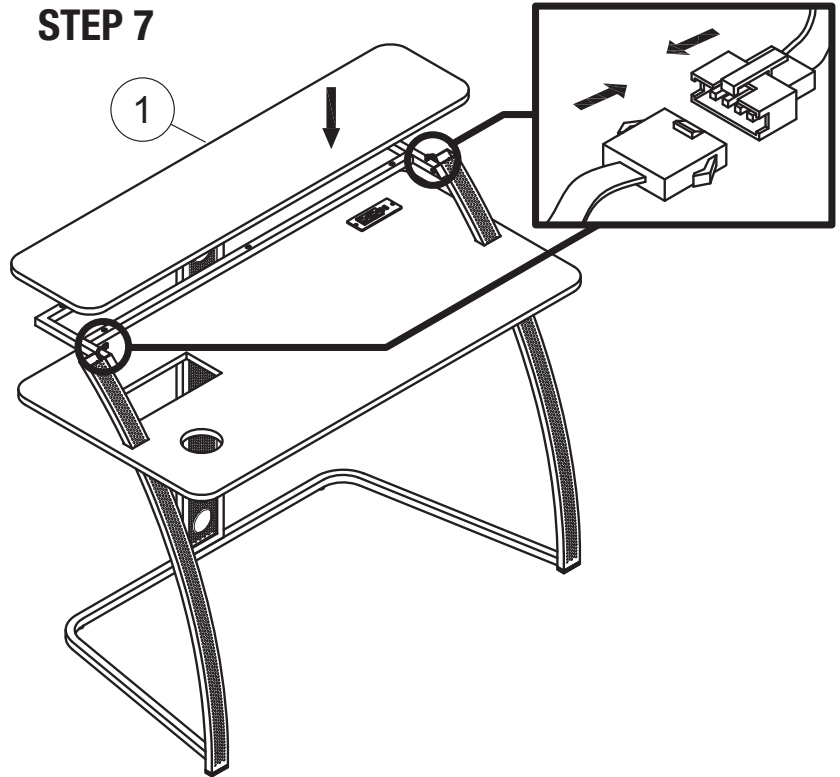

STEP 8

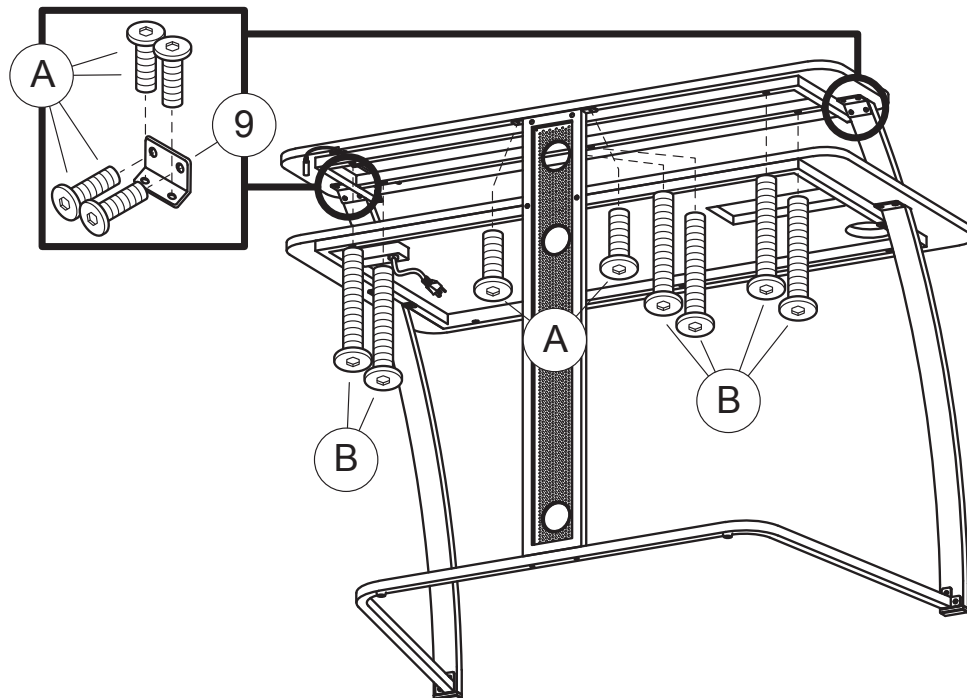

STEP 6 Attach Top Metal Frame (3) using four Allen Bolts (B). **FULLY TIGHTEN ALL ALLEN BOLTS.**

STEP 7 Place Top Panel (1) onto Top Metal Frame and connect the cables as shown.

STEP 8 Attach Top Panel to Legs using one Bracket (9) and four Allen Bolts (A) on each side. Attach Top Panel to Frame using six Allen Bolts (B). **FULLY TIGHTEN ALL ALLEN BOLTS.**

CDE30 BATTLESTATION GAMING DESK

ASSEMBLY INSTRUCTIONS

STEP 9

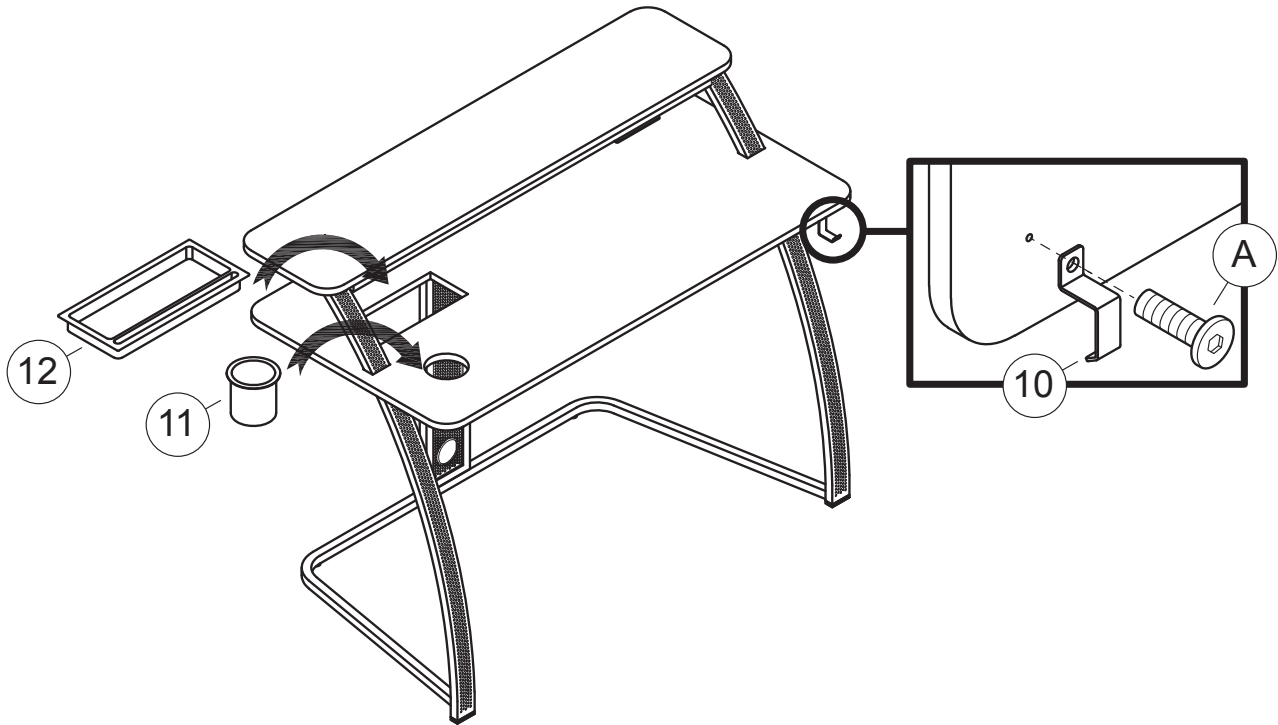

STEP 10

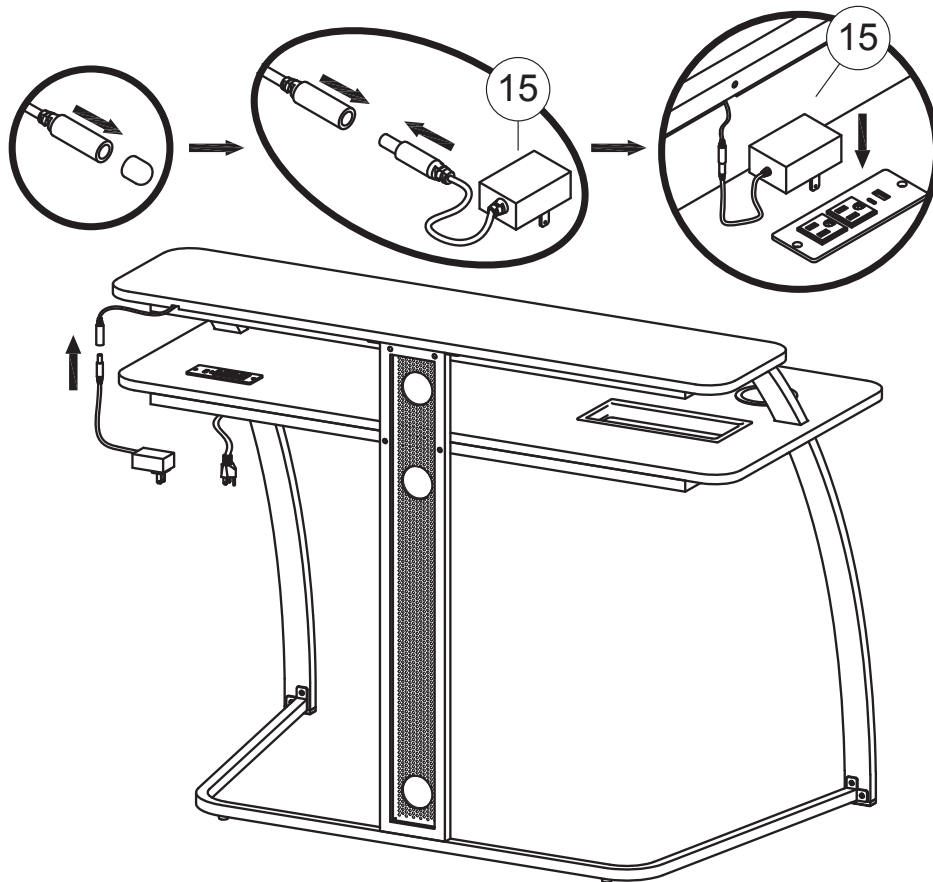

STEP 9 Insert Plastic Tray (12) and Plastic Cup Holder (11) into holes as shown. Attach Hook (10) under Desktop using Allen Bolt (A).

STEP 10 Remove cap from end of cable, and connect to LED Power Supply (15). Connect LED Power Supply (15) to Outlet on Desktop.

LED LIGHT REMOTE CONTROL – INSTRUCTIONS FOR USE

Your desk includes an integrated LED light strip with customizable RGB LED lights. The lights are controlled using the included LED Remote Control. Please refer to the Button Feature Diagram below for an outline of the remote's functions. A Troubleshooting FAQ is also included below for frequently asked questions and general usage troubleshooting. This remote uses a single CR2025 3V Lithium coin battery, located in the pull out battery tray tab on the back-bottom edge of the remote.

LED Light Remote Control: Button Feature Diagram

LED Brightness Increase/Decrease

Preset Fixed Red, Green, Blue (RGB) and White Color Section:

To select a preset color, simply press the desired color button within each of the RGB color mixtures to set the LED light color. The LED lights will change to a fixed (solid) color based on the selection.

Programmable Do-it-Yourself (DIY) Section:

To save your own custom fixed LED light color, follow the steps below:

1. Press any DIY # Button ONCE. The LED lights should change to solid white color.
2. Use any of the RGB DOWN arrows to REMOVE that respective color from the color mixture. To ADD a color back to the color mixture, use the respective RGB UP arrows.
3. When you have reached the desired custom LED color, press the SAME DIY # button that you selected in Step 1. The custom LED color is now saved, and can be recalled by pressing the DIY # button.

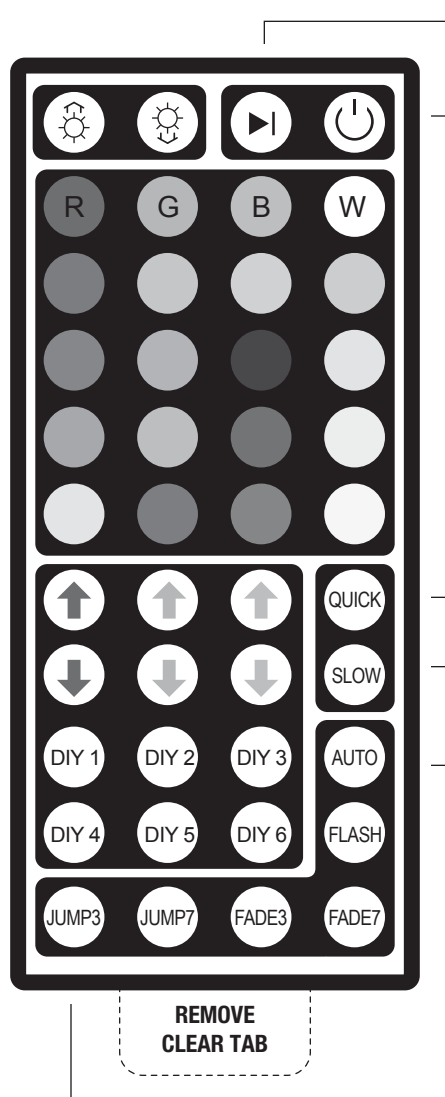

Pause/Play: Multi-Color Effects

LED Power: On/Off

NOTE: The LED lights should automatically power ON when the LED Power Supply is connected to a power outlet.

Speed Section:

Increase/Decrease transition speed of effects from the Multi-Color RGB Effects Section.

Multi-Color RGB Effects Section (Press to Select):

- **AUTO:** Automatically cycle through all RGB color ranges, while alternating between the "FLASH" and "FADE7" effects.
- **FLASH:** Cycle through all RGB color ranges, with an abrupt flashing transition effect between colors.
- **FADE7:** Cycle through all RGB color ranges, with a smooth fading transition effect between colors. See "Speed Section" for additional customization.
- **FADE3:** Cycle through only Red, Green, Blue colors, with a smooth fading transition between colors. See "Speed Section" for additional customization.
- **JUMP7:** Cycle through all RGB color ranges, with an abrupt transition from one color to the next. See "Speed Section" for additional customization.
- **JUMP3:** Cycle through only, Red, Green, Blue colors, with an abrupt transition between colors. See "Speed Section" for additional customization.

NOTE: When using the remote for the first time, you will need to pull the clear plastic tab out from the battery tray to activate it from storage mode. The remote will now function as shown.

TROUBLESHOOTING FAQ

Problem:	Solution:	Also Check:	Also Check:
LED Lights won't turn on?	Press the Power ON/OFF button	Double check that the LED Power Supply is connected to the LED strip on the desk and the power supply is plugged into a power outlet.	Remove the clear tab from the battery tray on first use. After prolonged usage, the battery (CR2025-3V Lithium) may need to be replaced.
DIY lights will not program?	When first programming the DIY section, the lights will start off white. Hold DOWN any of the RGB colored arrows firmly until you see the light begin to shift in color. Once a color range has been removed, it is easier to begin customizing the DIY color. Make sure to press the SAME DIY # button you first pressed during the programming process to save the custom color.		

FCC INSTRUCTIONS

NOTE: This equipment has been tested and found to comply with the limits for the Class B digital device, pursuant to Part 15 of the FCC Rules. These limits are designed to provide reasonable protection against harmful interferences in a residential installation. This equipment generates, uses and can radiate frequency energy and, if not installed and used in accordance with the instructions, may cause harmful interference to radio communications. However, there is no guarantee that interference will not occur in a particular installation. If this equipment does cause harmful interference to radio or television reception, which can be determined by turning the equipment off and on, the user is encouraged to try to correct the interference by one or more of the following measures:

- Reorient or relocate the receiving antenna.
 - Increase the separation between the equipment and receiver.
 - Connect the equipment into an outlet on a circuit different from that to which the receiver is connected.
 - Consult the dealer or an experienced radio/TV technician for help.
-
- This device complies with Part 15 of the FCC Rules. Operation is subject to the following two conditions: (1) This device may not cause harmful interference, and (2) this device must accept any interference received, including interference that may cause undesired operation.
-
- Instructions shall caution users that modifications not approved by part responsible for compliance could void user's authority to operate the equipment.