

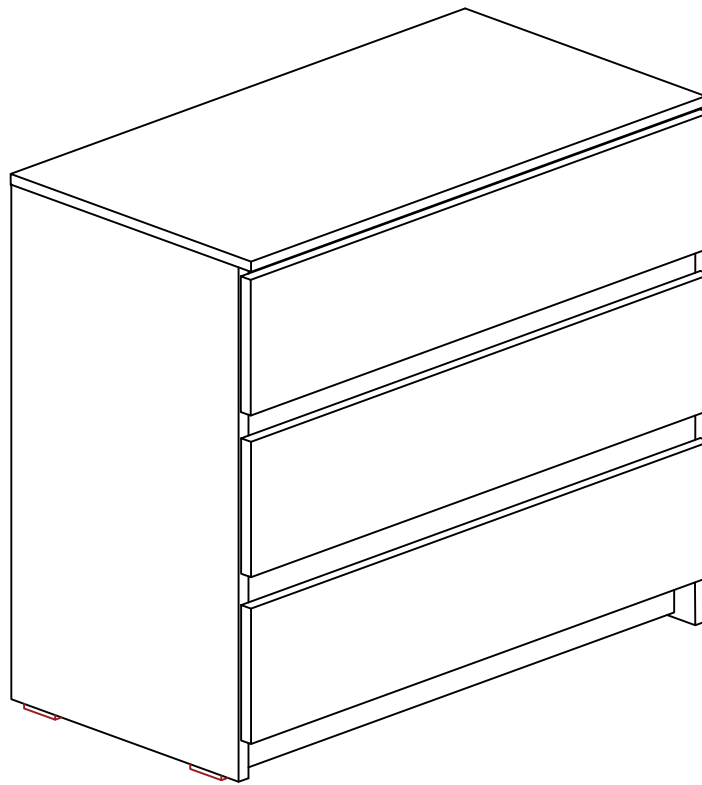

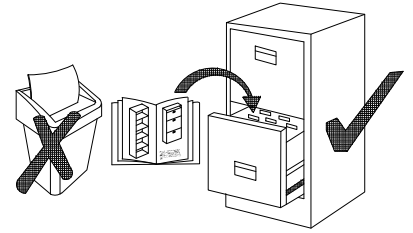









3 DRAWERS

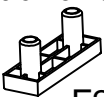

- PL - Instrukcja montażu
- DE - Montageanleitung
- GB - Assembly instruction
- FR - Mode d'emploi
- IT - Istruzione di montaggio
- CZ - Návod k montáži
- SK - Návod k montáži
- ES - Instrucciones de montaje



 17/310mm I2 6	 Ø15/12mm C 14	 Ø6x30mm A1 26	 Ø15/10mm C4 6	 L=30mm D5 20	 Ø6x42mm B2 12	 L3 20	 L 6
 6.5x48x16 F2 4	 Ø4.0x12mm R5 6	 Ø4x13mm P5 12	 E 6				

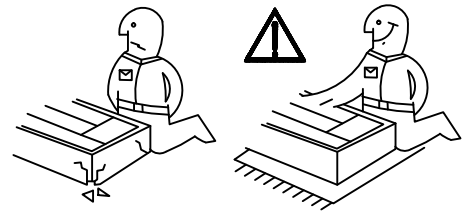
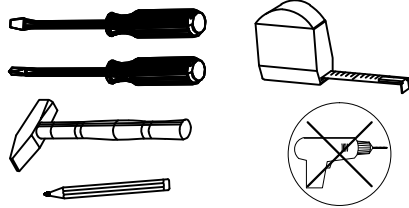
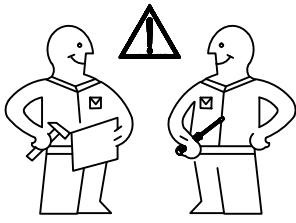

! UWAGA <> ACHTUNG <> WARNING <> ATTENTION <> AVVERTENZA <> UPOZORNĚNÍ <> UPOZORNENIE <> ADVERTENCIA !



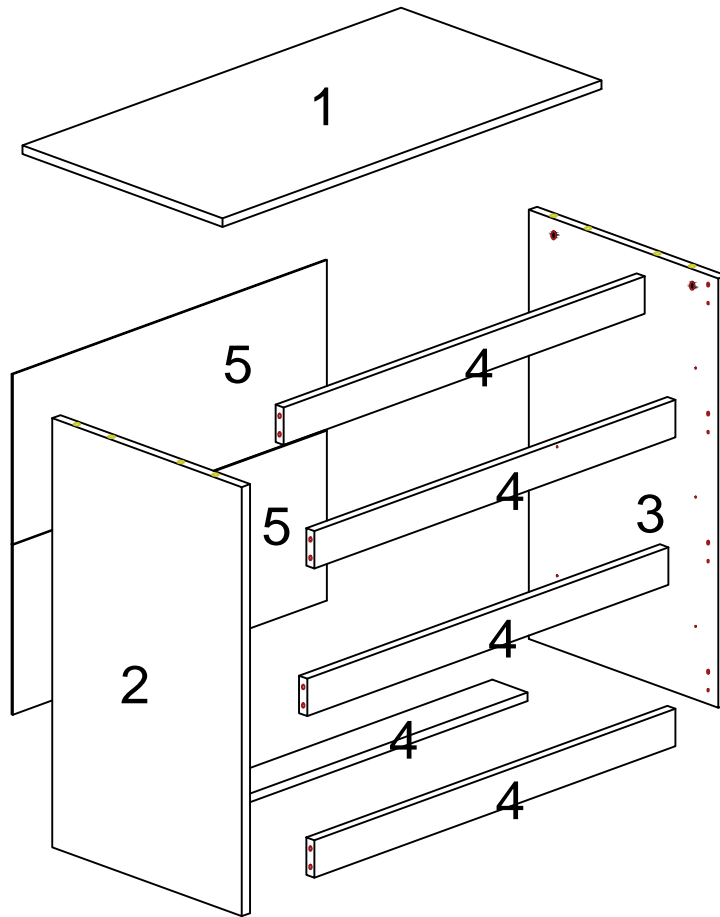

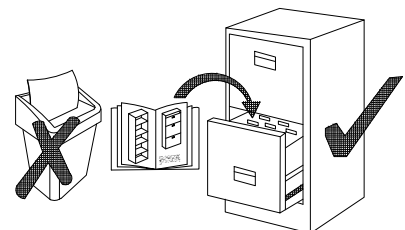

- PL - Czyszczenie należy wykonać wyłącznie za pomocą ściereczki lub lekko nawilżonego ręcznika. Nie stosować środków czyszczących do szorowania
- DE - Bitte nur mit einem Staubtuch oder leicht feuchtem Lappen reinigen. Keine scheuernden Putzmittel verwenden
- GB - Please only clean with a duster or a damp cloth. Do not use any abrasive cleaners
- FR - Le nettoyage doit être effectué uniquement avec un chiffon ou une serviette légèrement humidifiée. N'utilisez pas de nettoyeurs à récurer
- IT - La pulizia deve essere eseguita solo con un panno o un asciugamano leggermente inumidito. Non utilizzare detergenti abrasivi
- CZ - Čištění provádějte pouze hadříkem nebo mírně navlhčeným ručníkem. Nepoužívejte abrazivní čisticí prostředky
- SK - Čistenie by sa malo uskutočňovať iba pomocou handričky alebo mierne navlhčeného uteráka. Nepoužívajte čistiace prostriedky na čistenie
- ES - La limpieza debe realizarse solo con un paño o una toalla ligeramente humedecida. No use limpiadores desengrasantes



No.	Name	Dimension	Pcs.
1	TOP	700x370x15	1
2	LEFT SIDE	745x350x15	1
3	RIGHT SIDE	745x350x15	1
4	BRACKET	667x65x15	5
5	BACK PANNEL	696x354x3	2



1

17/310mm 	L=30mm 	Ø15/12mm 	Ø4x13mm 	6.5x48x16 	Ø6x30mm 
I2 3	D5 5	C 2	P5 6	F2 2	A1 2

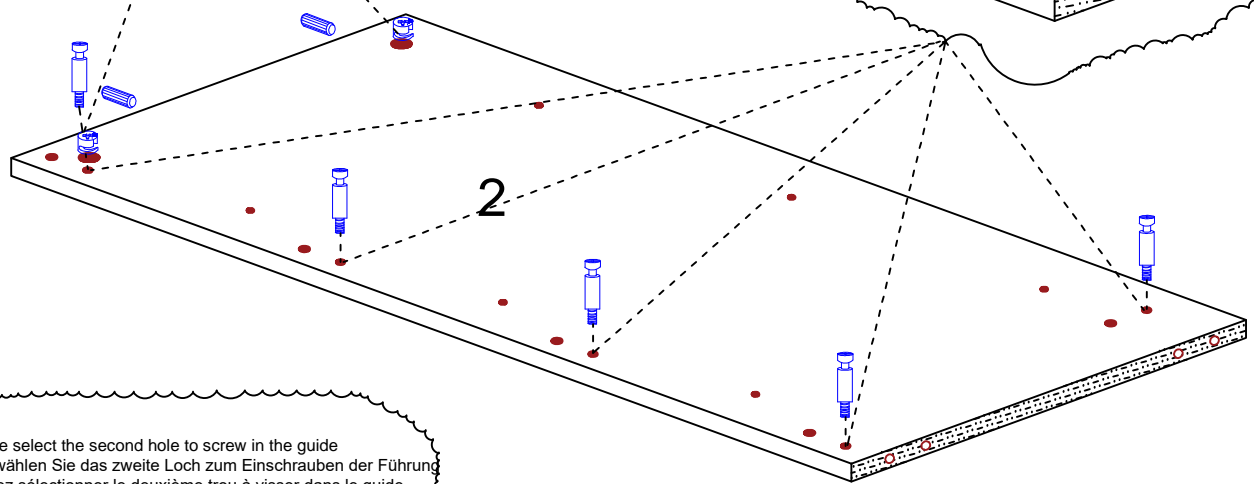
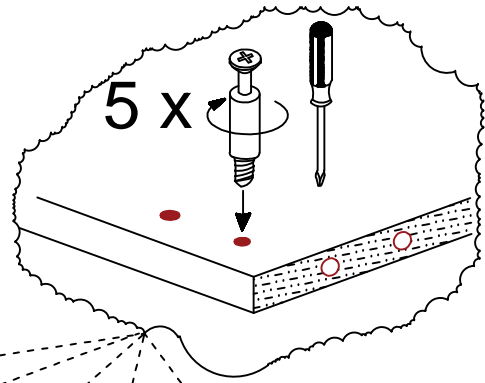
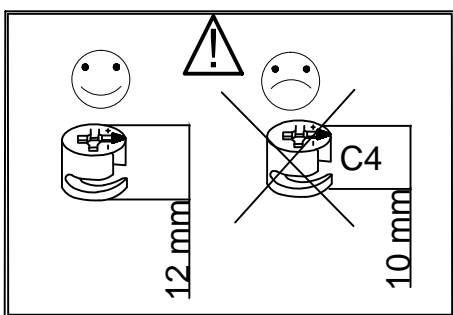
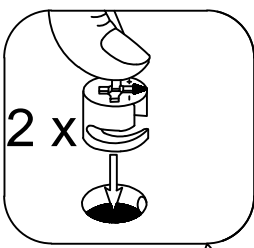
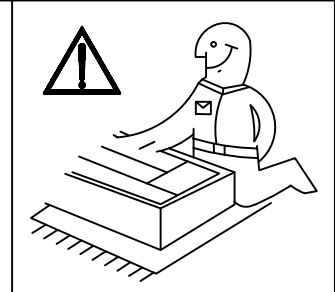

GB - Please select the second hole to screw in the guide
 DE - Bitte wählen Sie das zweite Loch zum Einschrauben der Führung
 FR - Veuillez sélectionner le deuxième trou à visser dans le guide

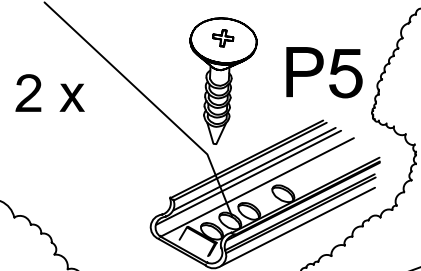



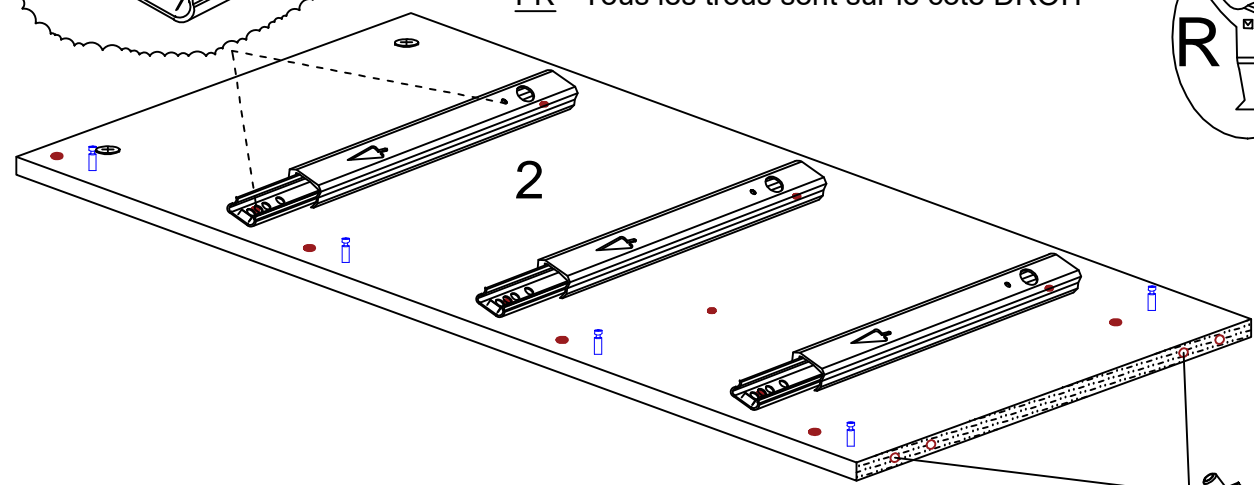
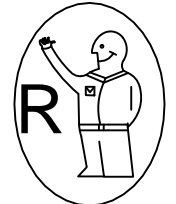



GB - All holes are on the RIGHT side
 DE - Alle Löcher sind auf der RECHTEN Seite
 FR - Tous les trous sont sur le côté DROIT

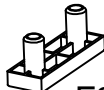

GB - ASSEMBLY THIS WAY
 DE - SO MONTIEREN
 FR - ASSEMBLAGE DE CETTE FAÇON

3

17/310mm  I2	L=30mm  D5	Ø15/12mm  C	Ø4x13mm  P5	6.5x48x16  F2	Ø6x30mm  A1
3	5	2	6	2	2

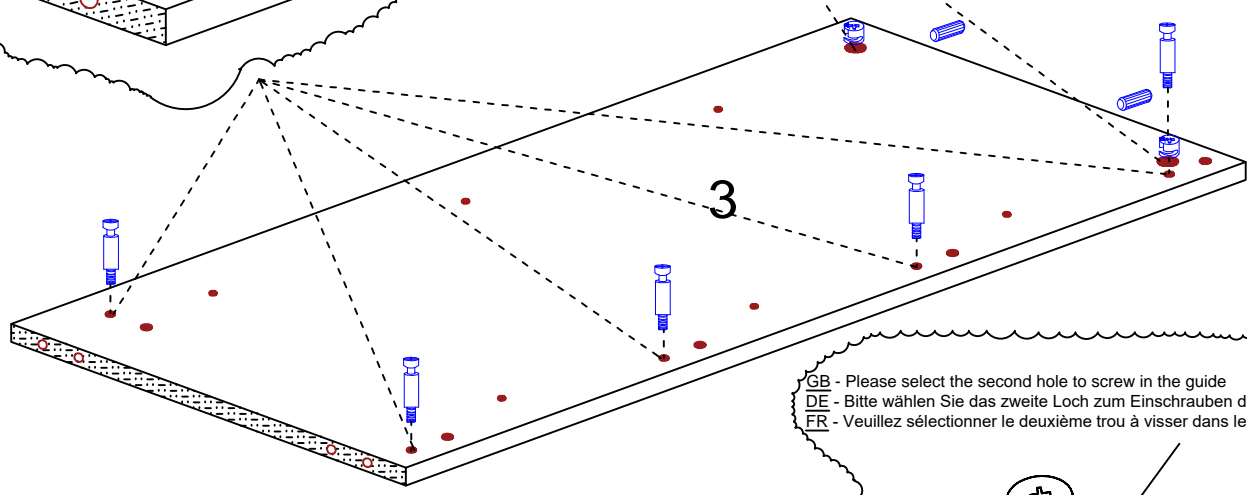
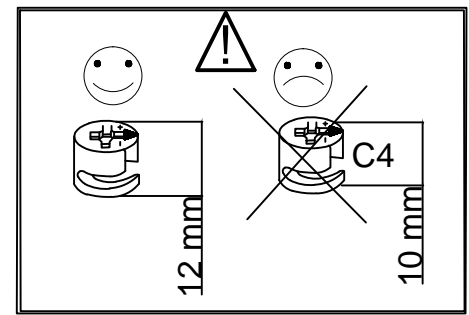
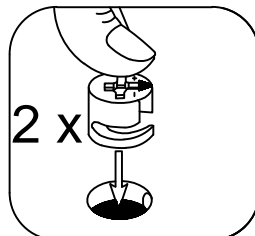
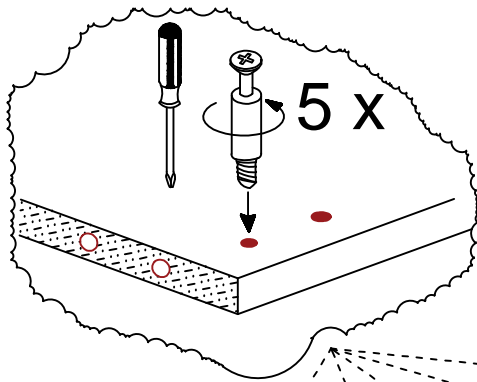
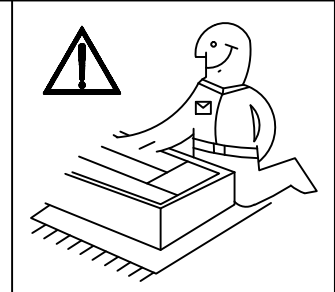

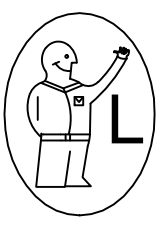

GB - Please select the second hole to screw in the guide
 DE - Bitte wählen Sie das zweite Loch zum Einschrauben der Führung
 FR - Veuillez sélectionner le deuxième trou à visser dans le guide

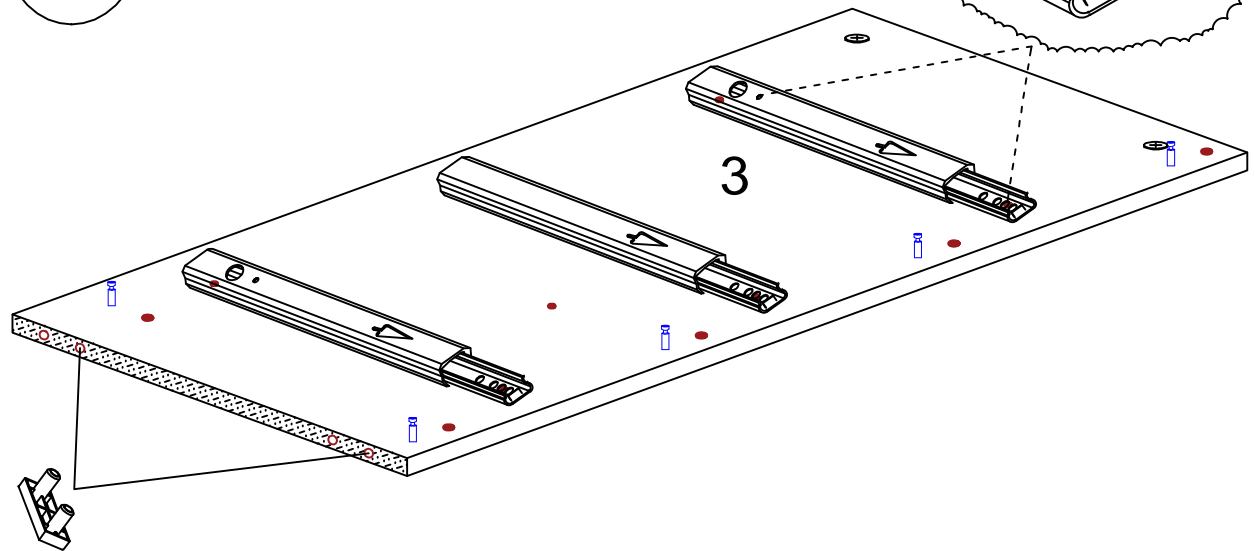
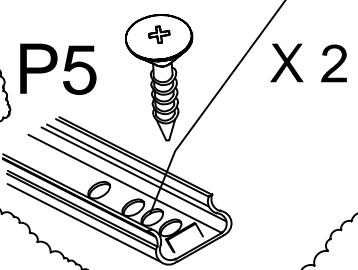

GB - All holes are on the LEFT side
 DE - Alle Löcher sind auf der LINKEN Seite
 FR - Tous les trous sont sur le côté GAUCHE



3

Ø15/12mm  C 10	L=30mm  D5 4	Ø6x30mm  A1 10
--	--	--

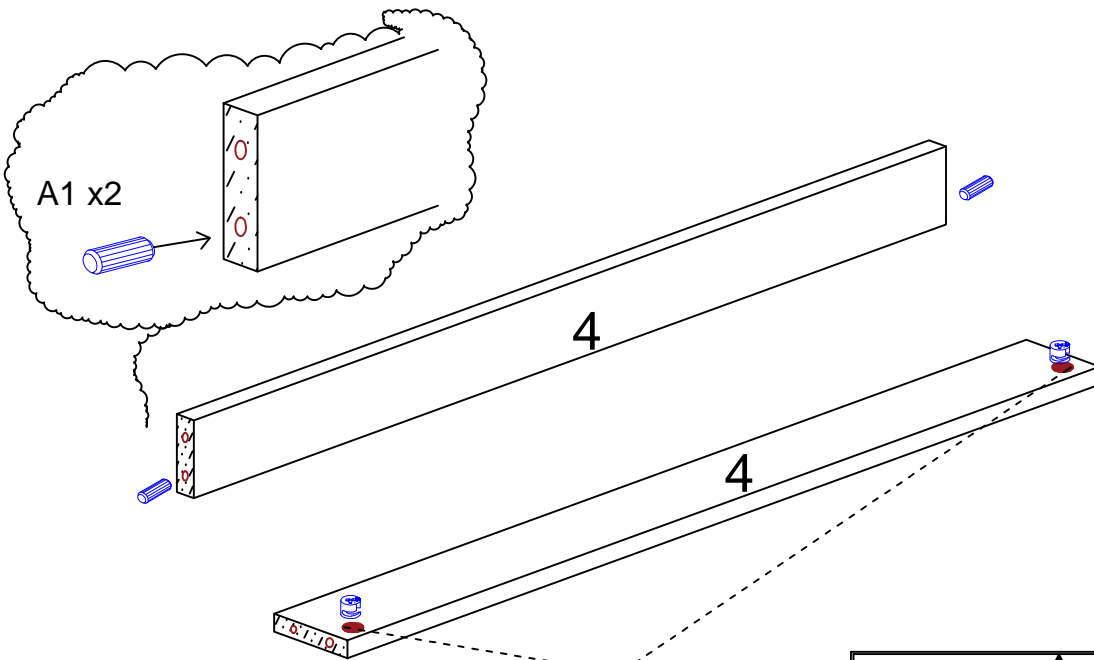
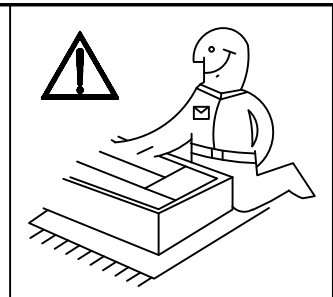

4

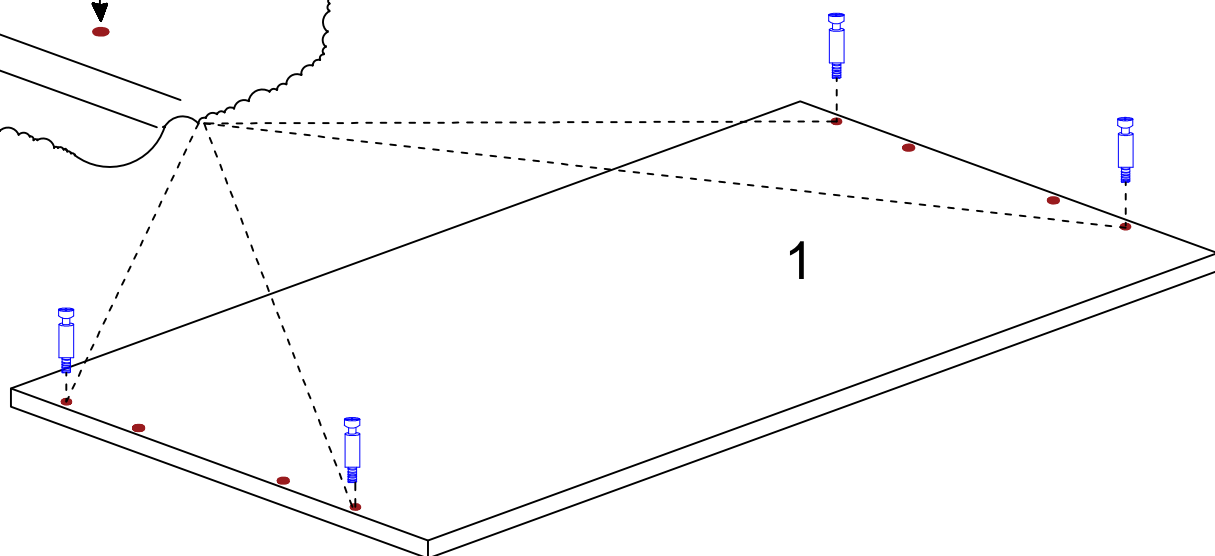
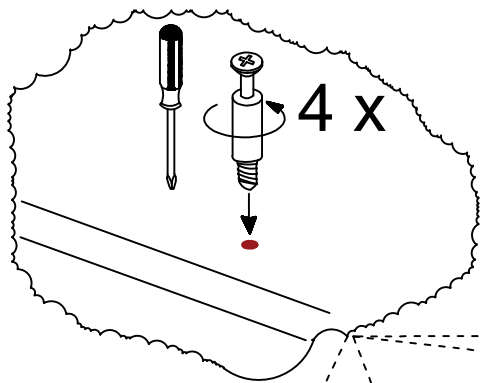
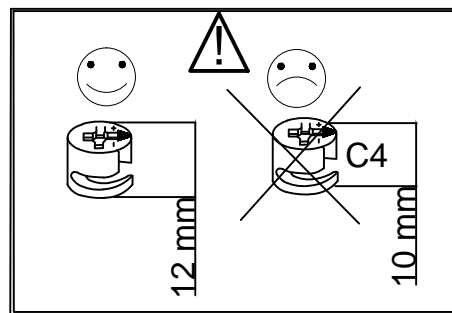
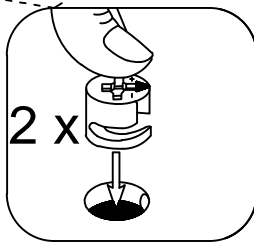

5

5

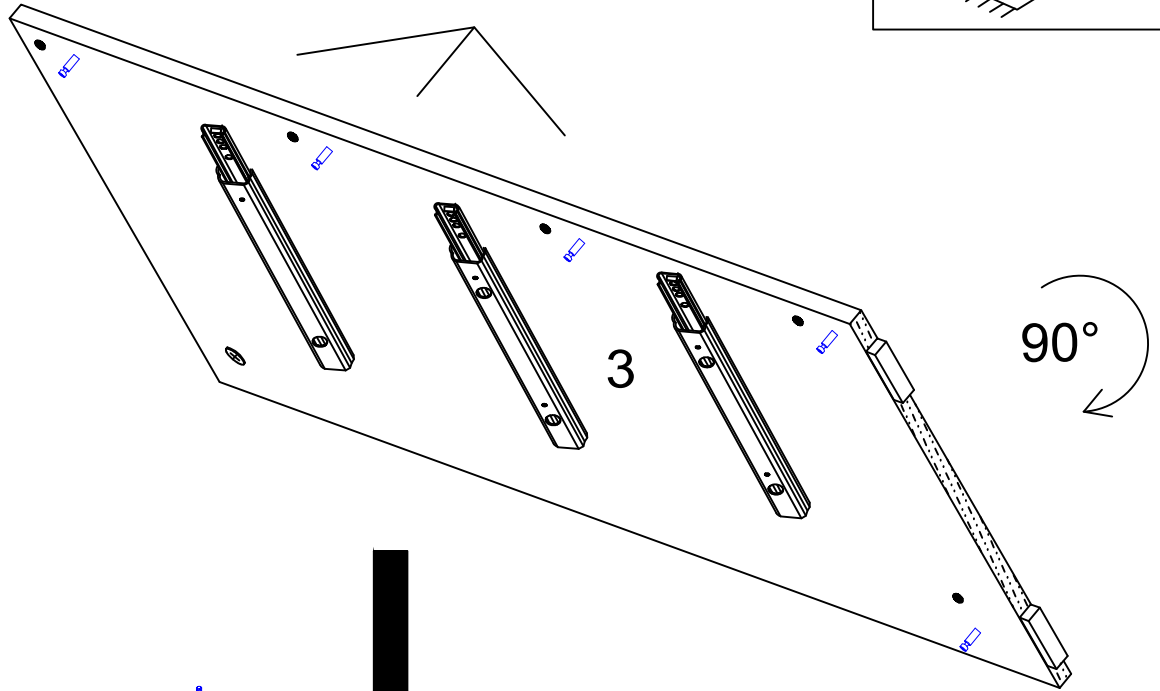
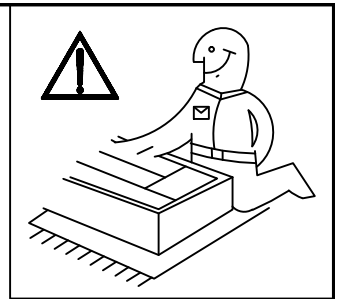
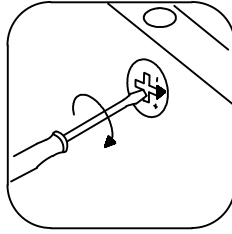
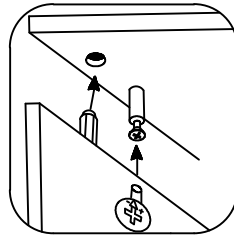

90°

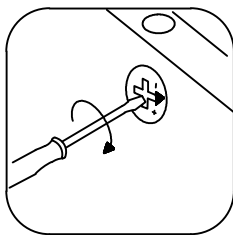
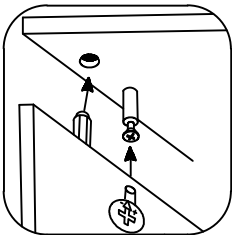
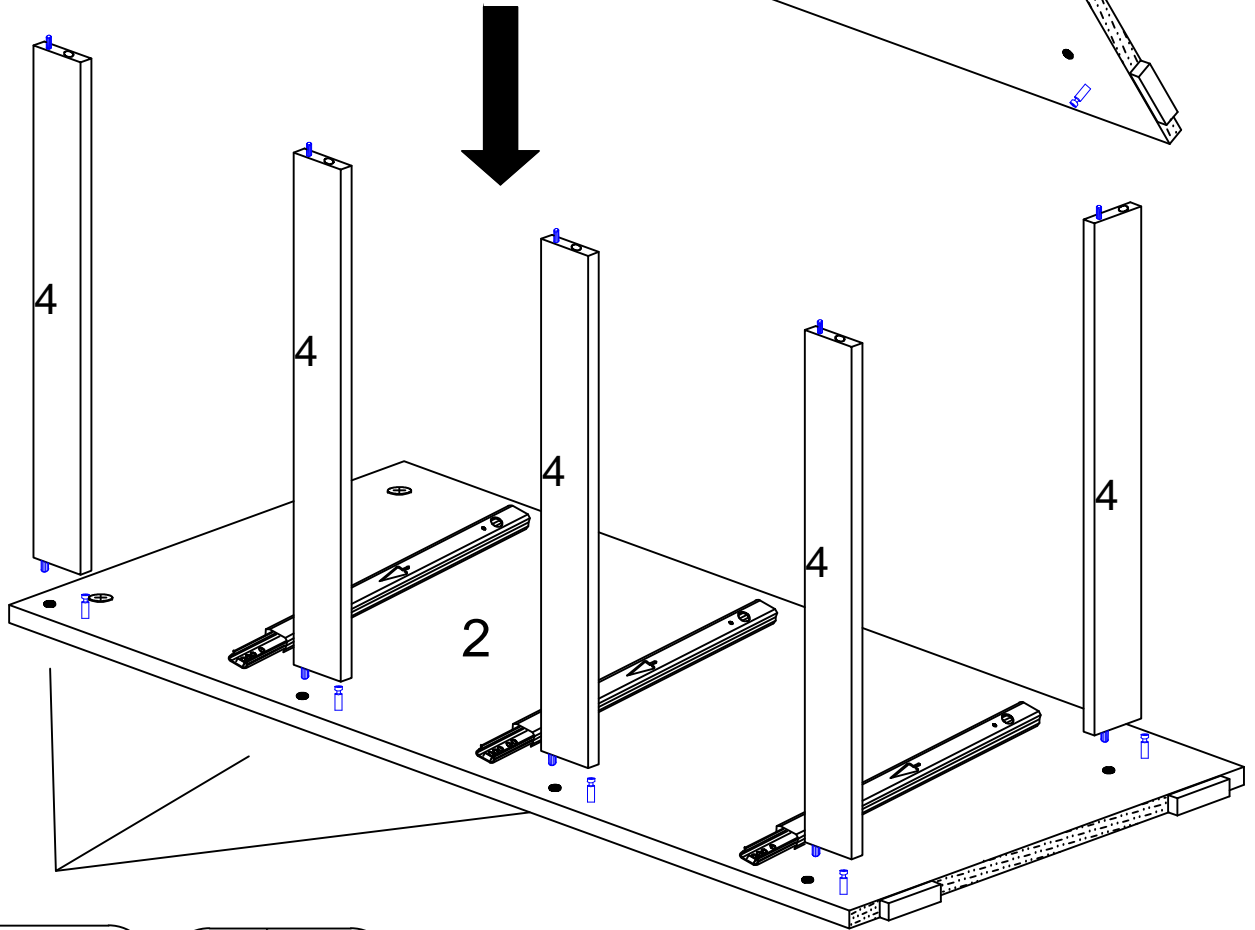

6

6

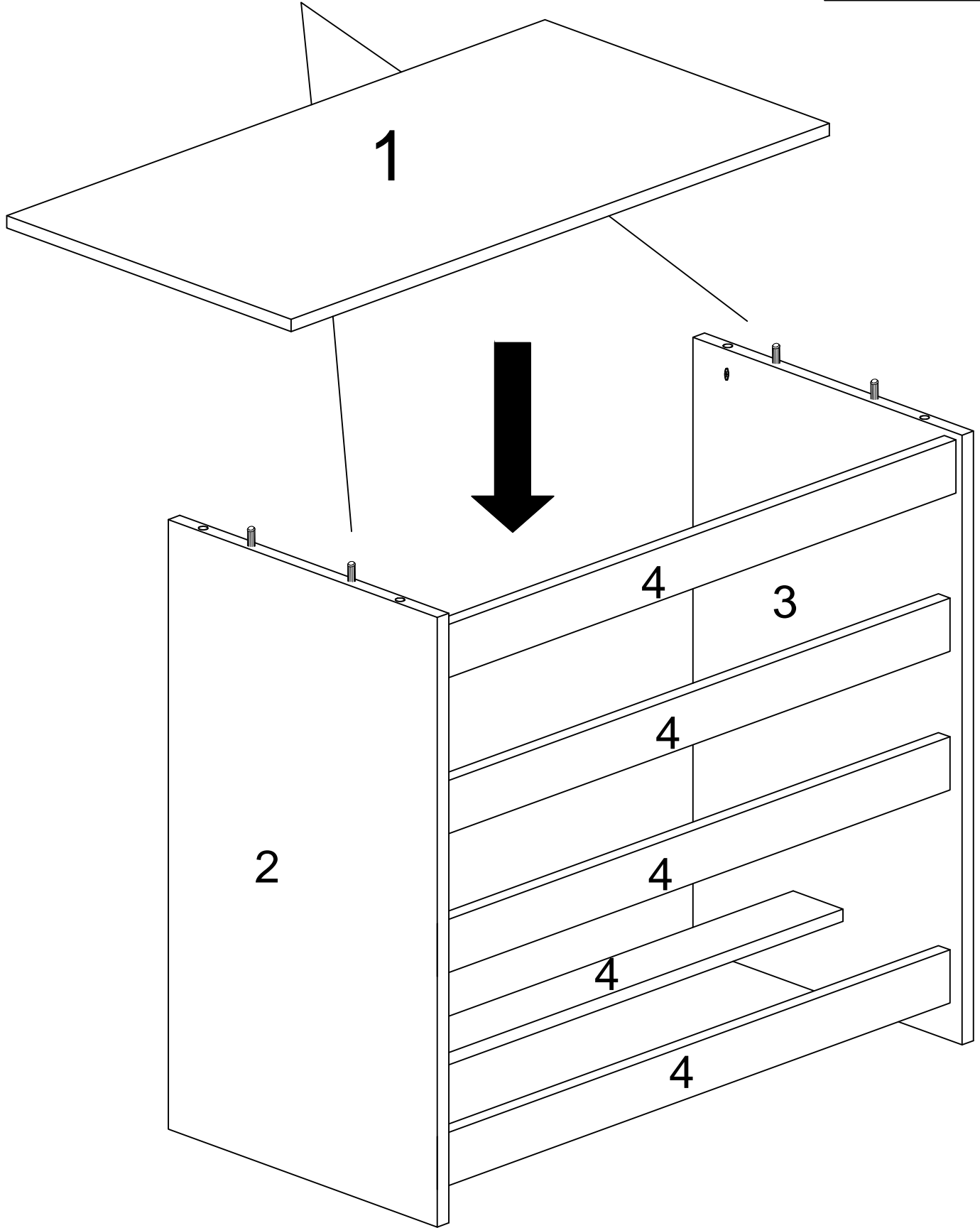
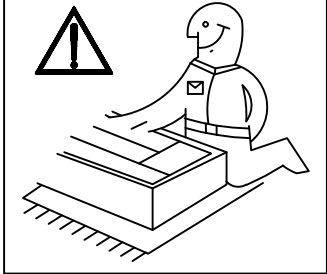
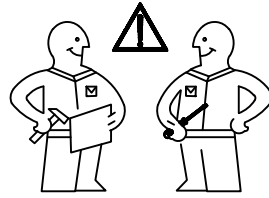
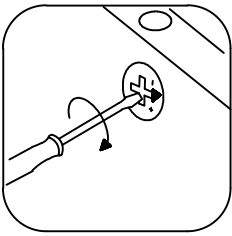
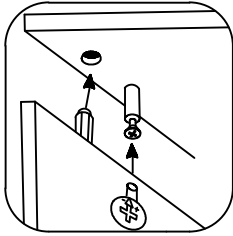

7

7

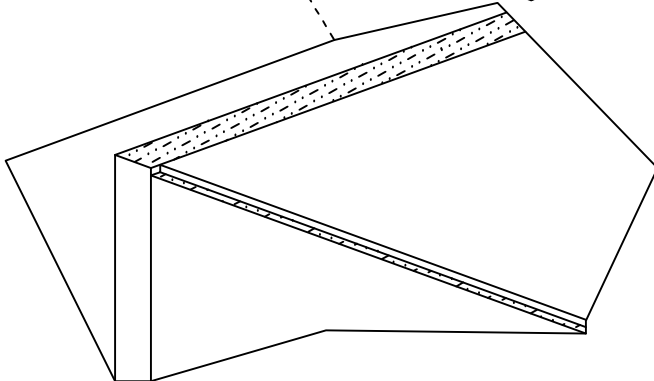
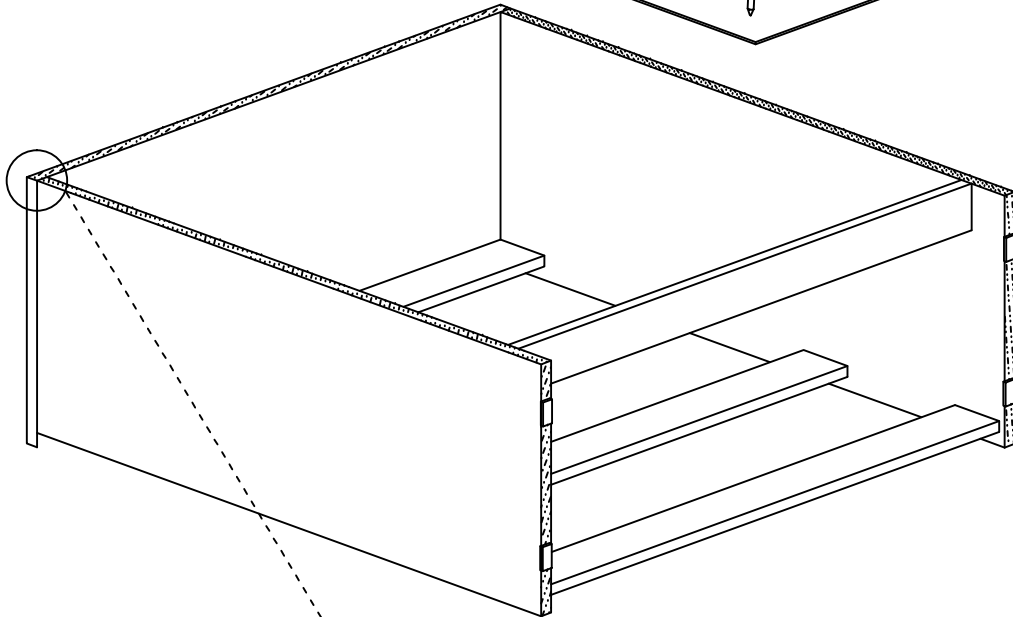
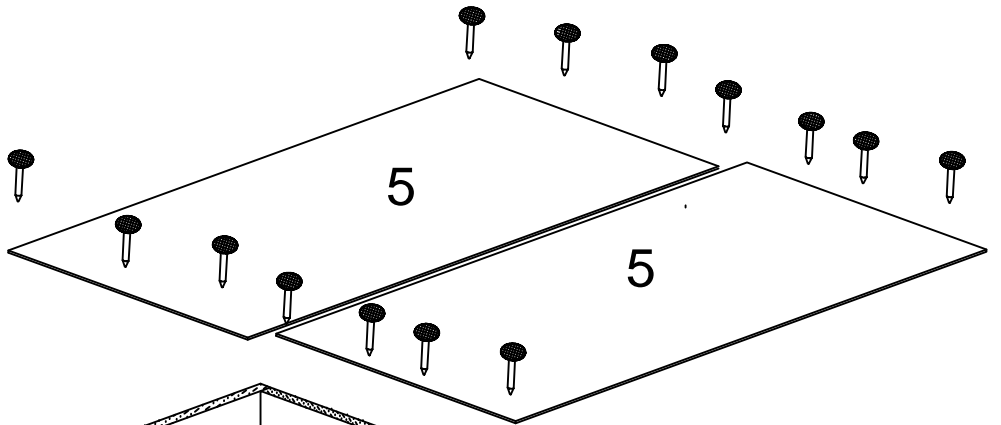
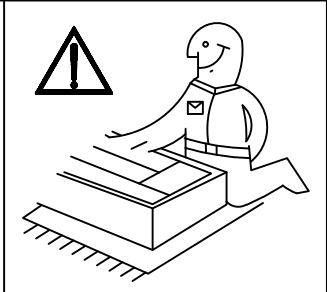
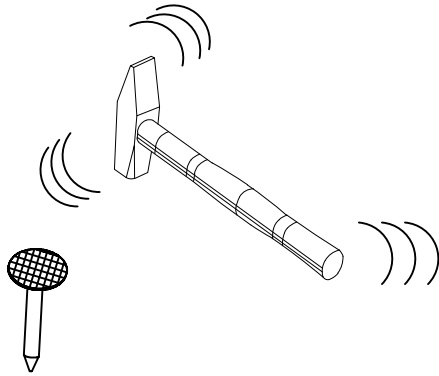
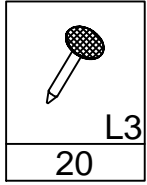

8

DRAWER ASSEMBLY

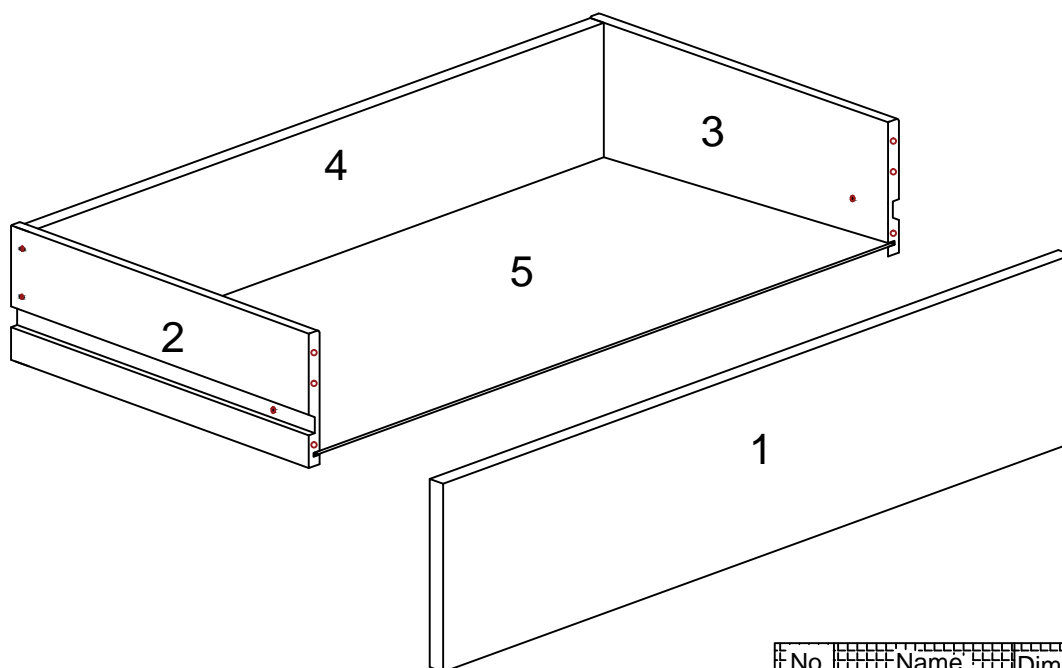
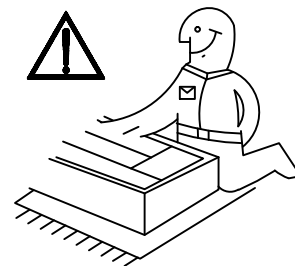
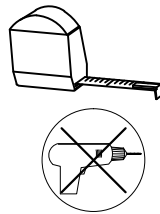
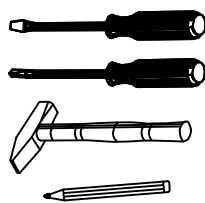

No.	Name	Dimension	Pcs.
1	FRONT	697x196x15	1
2	LEFT SIDE	325x140x12	1
3	RIGHT SIDE	325x140x12	1
4	BACK	637x140x12	1
5	BOTTOM	645x317x3	1



UWAGA <> ACHTUNG <> WARNING <> ATTENTION <> AVVERTENZA <> UPOZORNĚNÍ <> UPOZORNENIE <> ADVERTENCIA

PL - Umieść najcięższe przedmioty w dolnej szufladzie. Nie stawiaj na meblu telewizora lub innych ciężkich przedmiotów. Nigdy nie pozwalaj dzieciom wspinać po szufladach lub wchodzić do nich.

DE - Legen Sie die schwersten Gegenstände in die untere Schublade. Stellen Sie den Fernseher oder andere schwere Gegenstände nicht auf die Möbel. Lassen Sie Kinder niemals über Schubladen klettern oder diese betreten

GB - Place the heaviest items in the bottom drawer. Do not place the TV or other heavy objects on the furniture. Never allow children to climb over drawers or enter them

FR - Placez les articles les plus lourds dans le tiroir du bas. Ne placez pas le téléviseur ou d'autres objets lourds sur les meubles. Ne laissez jamais les enfants grimper sur les tiroirs ou y entrer.



IT - Metti gli oggetti più pesanti nel cassetto in basso. Non posizionare il televisore o altri oggetti pesanti sui mobili. Non permettere mai ai bambini di scavalcare i cassetti o di entrarvi.

CZ - Nejtěžší předměty vložte do spodní zásuvky. Nepokládejte televizor ani jiné těžké předměty na nábytek. Nikdy nedovoďte dětem šplhat přes zásuvky nebo do nich vstupovat.

SK - Najťažšie predmety vložte do spodnej zásuvky. Televízor ani iné ťažké predmety neumiestňujte na nábytok. Nikdy nedovoľte deťom preliezať zásuvky alebo do nich vstupovať.

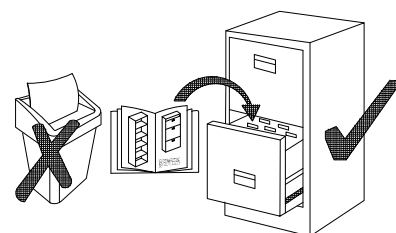
ES - Coloque los artículos más pesados en el cajón inferior. No coloque el televisor u otros objetos pesados sobre los muebles. Nunca permita que los niños se suban a los cajones o los entren.

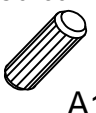

L=30mm  D5 2	Ø6x30mm  A1 4	Ø15/10mm  C4 2
--	---	--

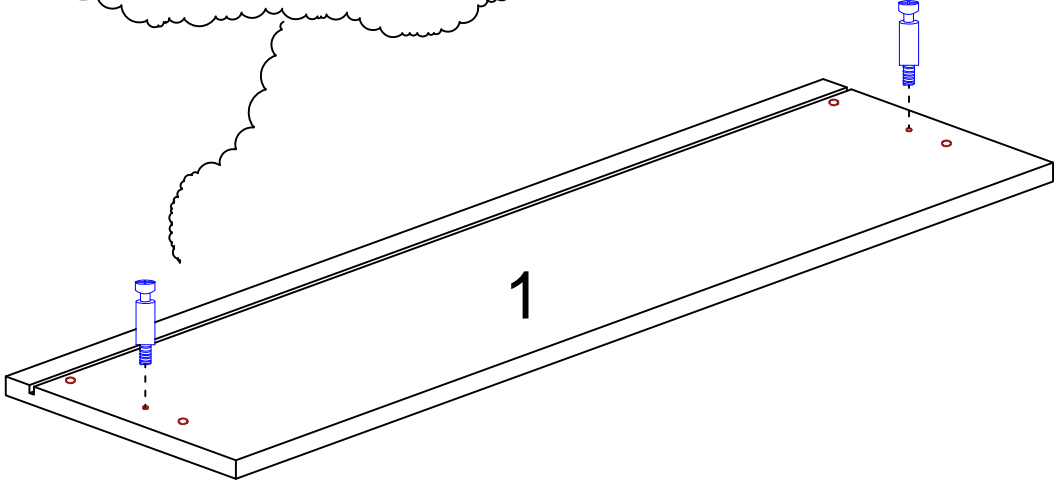
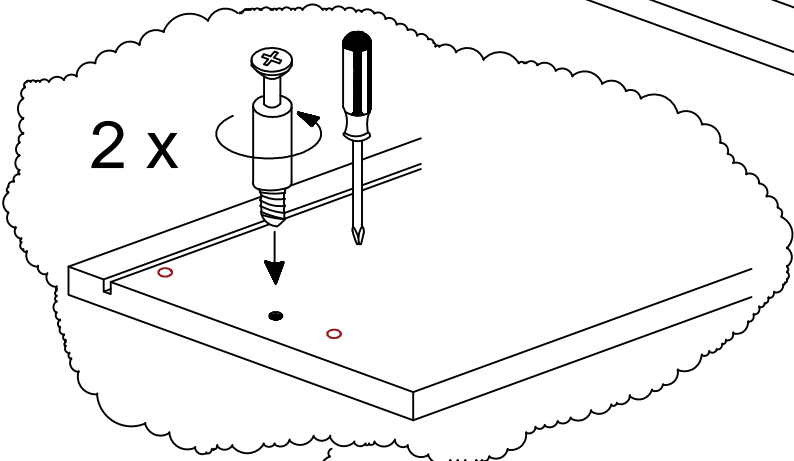
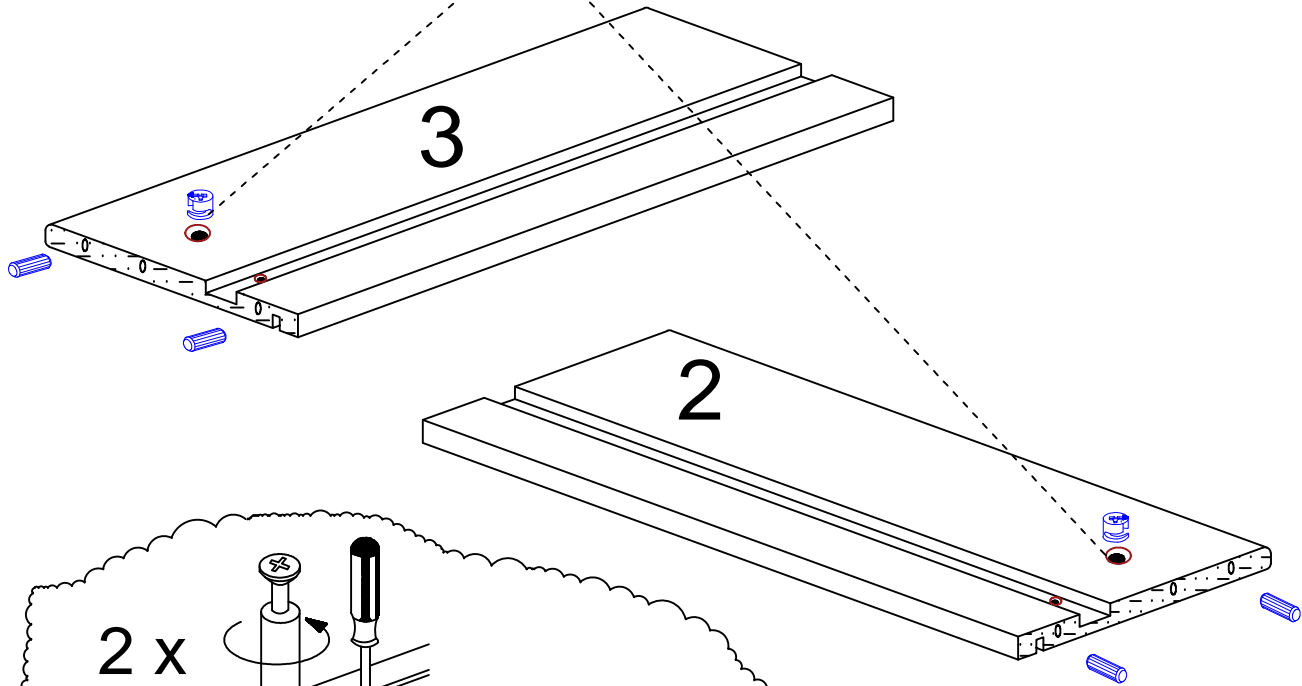
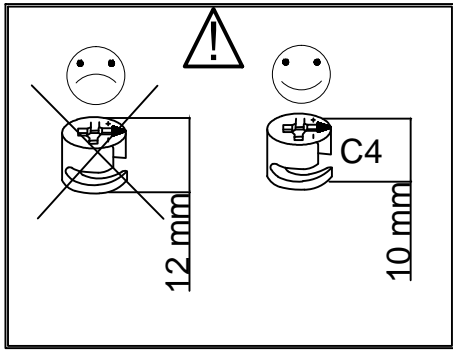
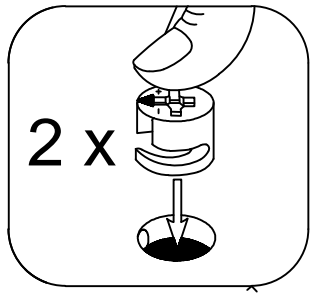
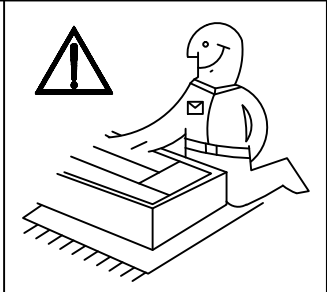

9

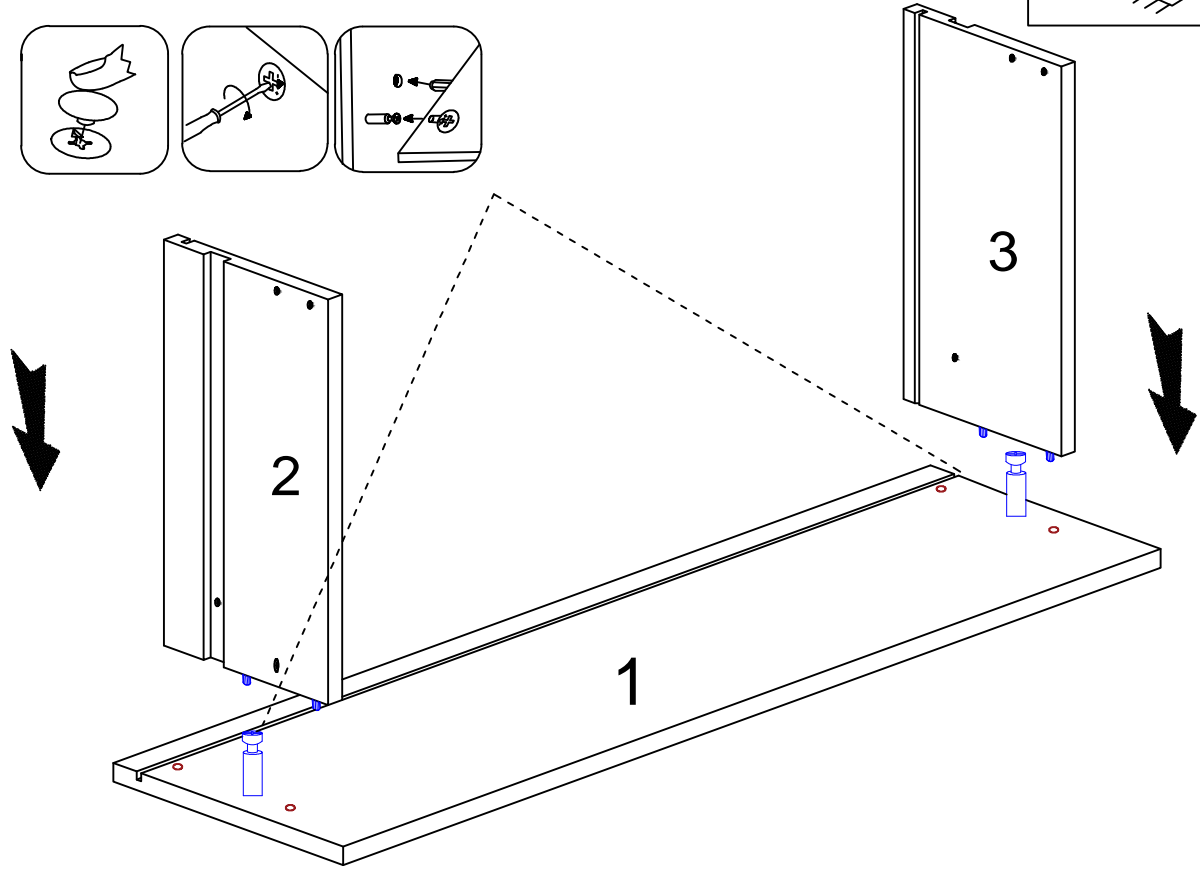
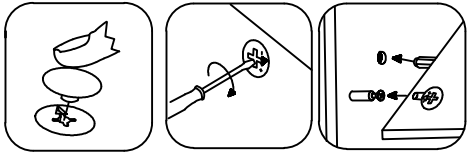
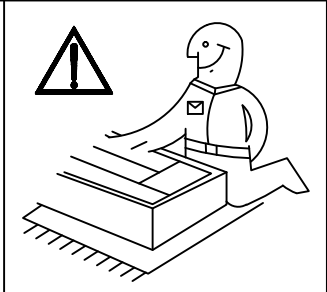

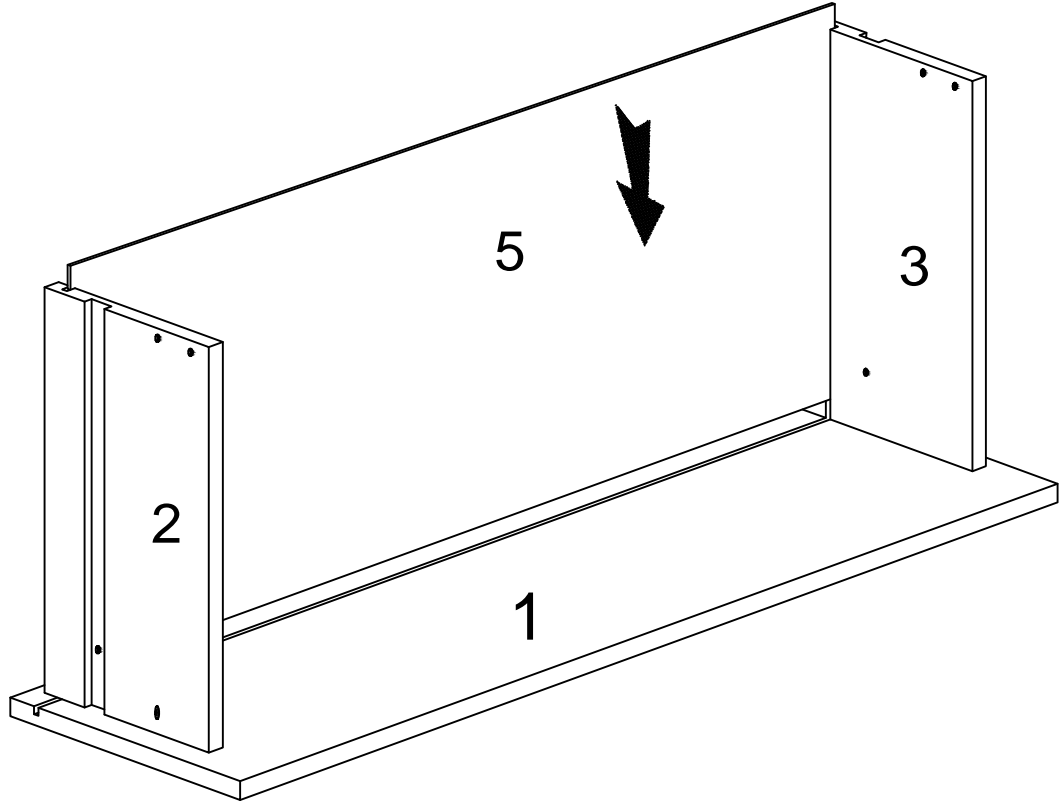

10



11

11

$\varnothing 6 \times 42 \text{mm}$  B2	 L
4	2

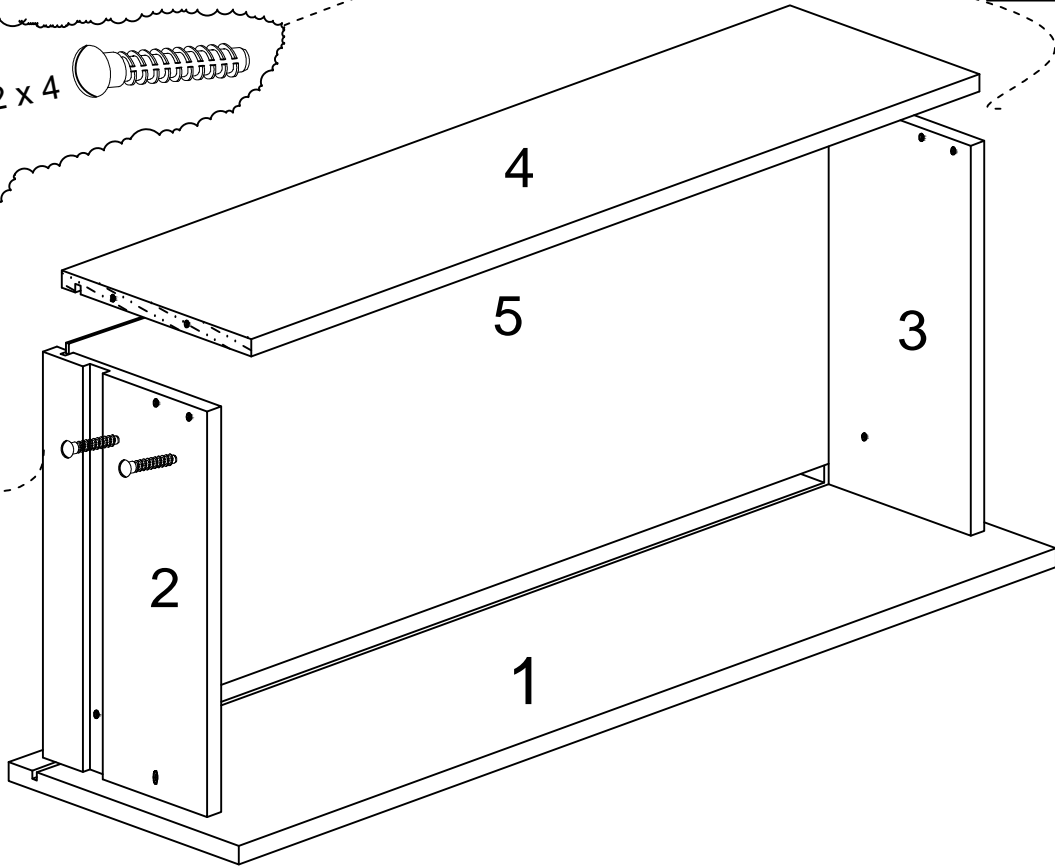
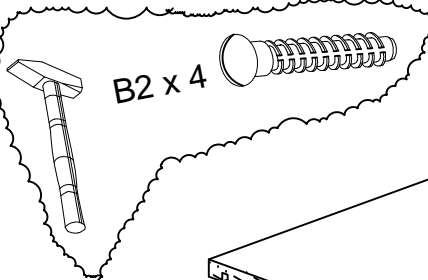
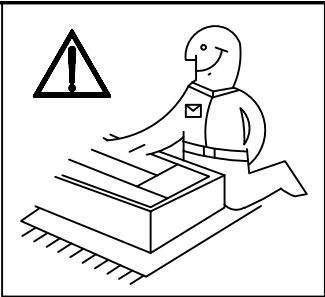

12

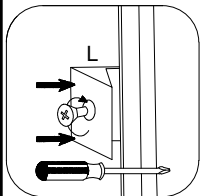
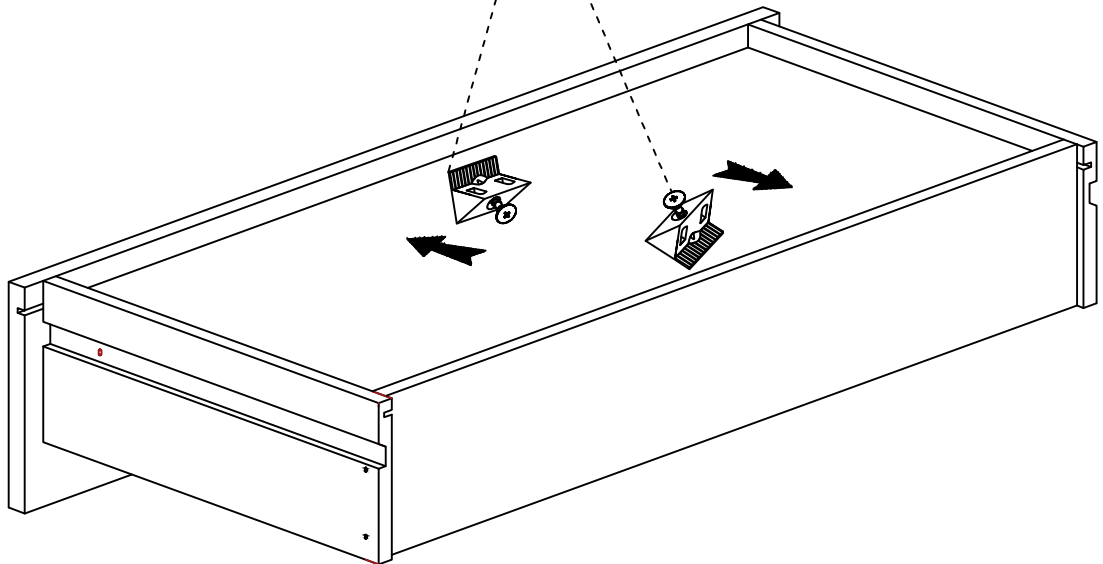
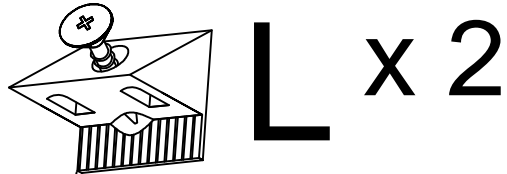

11

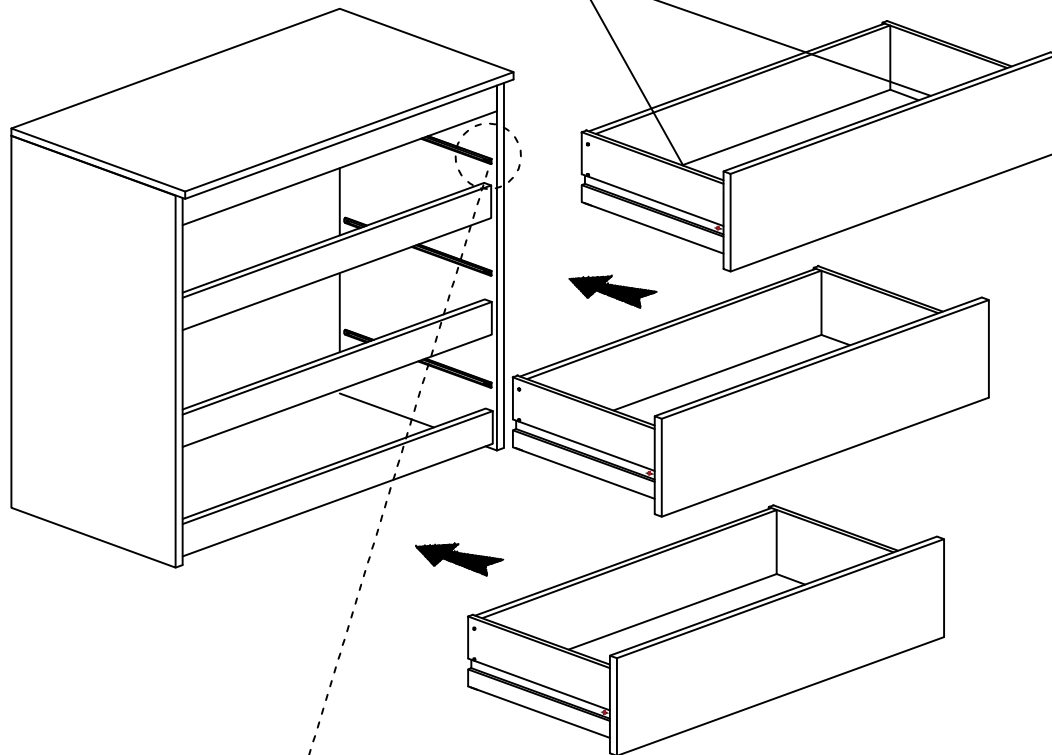
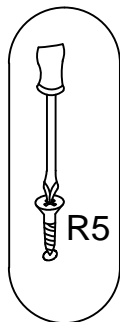
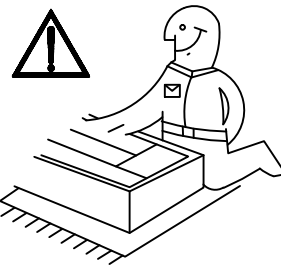
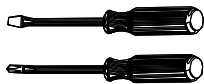
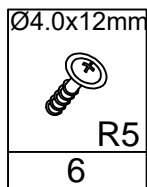

UWAGA <> ACHTUNG <> WARNING <>
ATTENTION <> AVVERTENZA <>
UPOZORNĚNÍ <> UPOZORNENIE <>
ADVERTENCIA

PL - Podczas montażu szuflada może ciasno wchodzić.

DE - Bei der Montage kann die Schublade fest sitzen

GB - When assembling, the drawer can fit tightly

FR - Lors de l'assemblage, le tiroir peut s'adapter étroitement

IT - Durante il montaggio, il cassetto può adattarsi saldamente

CZ - Během montáže se zásuvka může pevně vejít

SK - Pri montáži sa zásuvka môže pevne zmestiť

ES - Durante el montaje, el cajón puede caber bien

GB - Please select second hole to screw in the drawer
DE - Bitte wählen Sie das zweite Loch, um schraube in die schublade
FR - Veuillez sélectionner le deuxième trou pour visser dans le tiroir

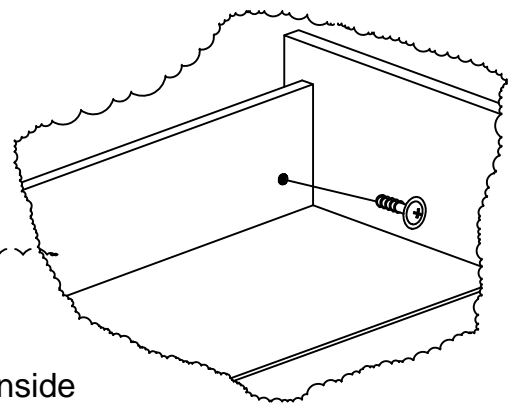
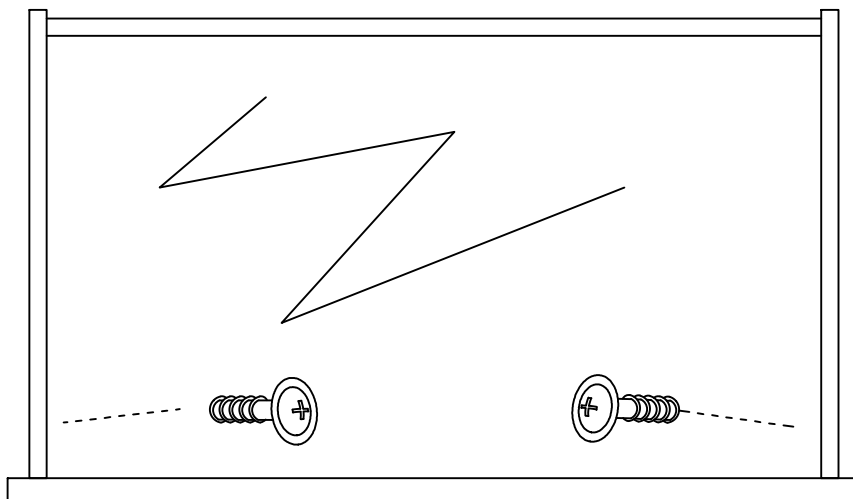
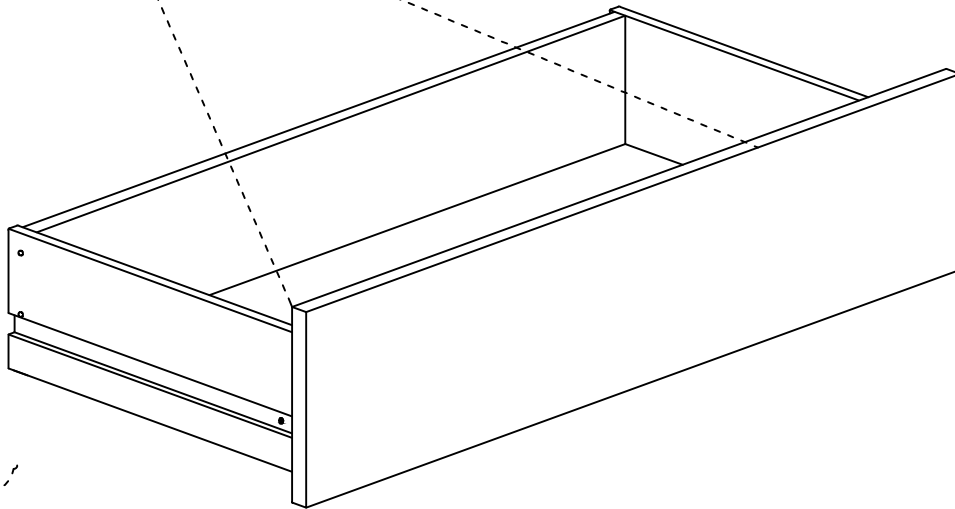
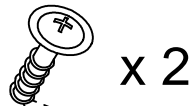
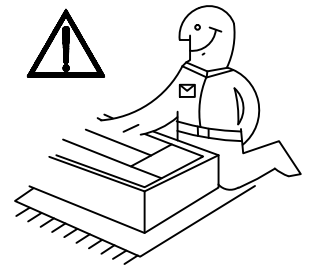
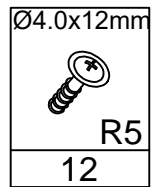

GB - Screw the drawer into the guide from the inside

DE - Schrauben Sie die Schublade von innen in die Führung ein

FR - Visser le tiroir dans le guide de l'intérieur



UWAGA <> ACHTUNG <> WARNING <> ATTENTION <> AVVERTENZA <> UPOZORNĚNÍ <> UPOZORNENIE <> ADVERTENCIA

PL - Mebel wykonany z płyt drewnopodobnych.

Podstawowe zasady:

- Nie stawiać na meblach gorących przedmiotów
- Nie stawiać świeczek bezpośrednio na meblach
- W przypadku rozlania wody natychmiast ją wytrzeć
- Sprawdzić w regularnych odstępach czasu, czy śruby są dokręcone a okucia dobrze przymocowane

DE - Ein Möbelstück aus holzähnlichen Platten.

Grundregeln:

- Stellen Sie keine heißen Gegenstände auf die Möbel
- Stellen Sie keine Kerzen direkt auf Möbel
- Verschüttetes Wasser sofort aufwischen
- Kontrollieren Sie in regelmäßigen Abständen, ob die Schrauben fest angezogen sind und die Beschläge sicher befestigt sind

GB - Furniture made of wood-like panels.

Basic rules:

- Do not place hot objects on the furniture
- Do not put candles directly on furniture
- If water is spilled, wipe it up immediately
- Check at regular intervals that the screws are tightened and the fittings are securely fastened

FR - Un meuble en panneaux imitation bois.

Règles de base:

- Ne posez pas d'objets chauds sur les meubles
- Ne pas mettre de bougies directement sur les meubles
- Si de l'eau est renversée, essuyez-la immédiatement
- Vérifier à intervalles réguliers que les vis sont bien serrées et que les ferrures sont solidement fixées

IT - Un mobile realizzato con pannelli simil legno.

Regole di base:

- Non appoggiare oggetti caldi sui mobili
- Non mettere le candele direttamente sui mobili
- Se viene versata dell'acqua, pulirla immediatamente
- Controllare ad intervalli regolari che le viti siano serrate e che i raccordi siano ben fissati

CZ - Kus nábytku ze dřeva podobných panelů.

Základní pravidla:

- Na nábytek nepokládejte horké předměty
- Nedávejte svíčky přímo na nábytek
- Pokud dojde k rozliti vody, ihned ji otřete
- Pravidelně kontrolujte, zda jsou šrouby pevně utažené a zda jsou pevně utažené

SK - Kus nábytku vyrobený z dosiek podobných drevu.

Základné pravidlá:

- Na nábytok nekladte horúce predmety
- Nedávajte sviečky priamo na nábytok
- Ak dôjde k rozliatiu vody, ihneď ju utrite
- Pravidelne kontrolujte dotiahnutie skrutiek a upevnenie armatúr

ES - Un mueble hecho de paneles similares a la madera.

Reglas básicas:

- No coloque objetos calientes sobre los muebles
- No coloque velas directamente sobre los muebles.
- Si se derrama agua, límpiela inmediatamente.
- Compruebe a intervalos regulares que los tornillos estén apretados y que los accesorios estén bien sujetos