

WIDE SHOE CABINET

Assembly instruction- Please keep for future reference

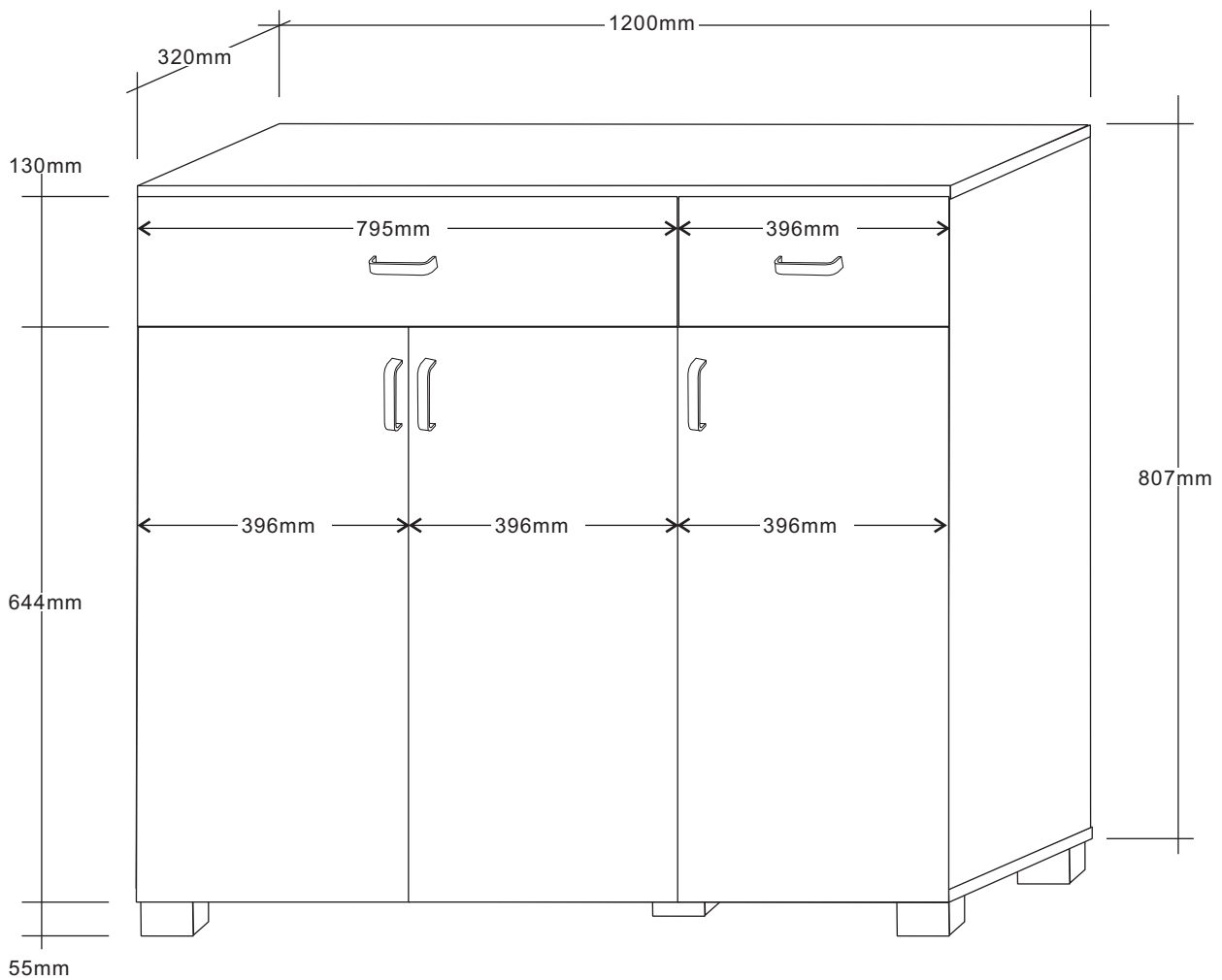

Dimensions	No. People	Assembly Time
Width: 120 cm Depth: 32 cm Height: 80.7 cm		60 mins (approx)

Important-Please read these instructions fully before starting assembly

⚠ Safety and Care Advice

Important-Please read these instructions fully before starting assembly

- Check you have all the components and tools listed on pages 2,3 and 4.
- Remove all fittings from the plastic bags and separate them into their groups.
- Keep children and animals away from the work area, small parts could choke if swallowed.
- Make sure you have enough space to lay out the parts before starting.
- Do not stand or put weight on the product, this could cause damage.
- Assemble the item as close to its final position (in the same room) as possible.
- Assemble on a soft, level surface to avoid damaging the unit or your floor.
- We do not recommend the use of power drill/drivers for inserting screw, as this could damage the unit. only use hand screwdrivers.
- Dispose of all packaging carefully and responsibly.



Care and Maintenance

- Only clean using a damp cloth and mild detergent, do not use bleach or abrasive cleaners.
- From time to time check that there are no loose screws on this unit.
- This product should not be discarded with household waste. Take to your local authority waste disposal centre.

If you are unhappy with the product and wish to return it, please following the retailer's returns procedure.

Components - Panels

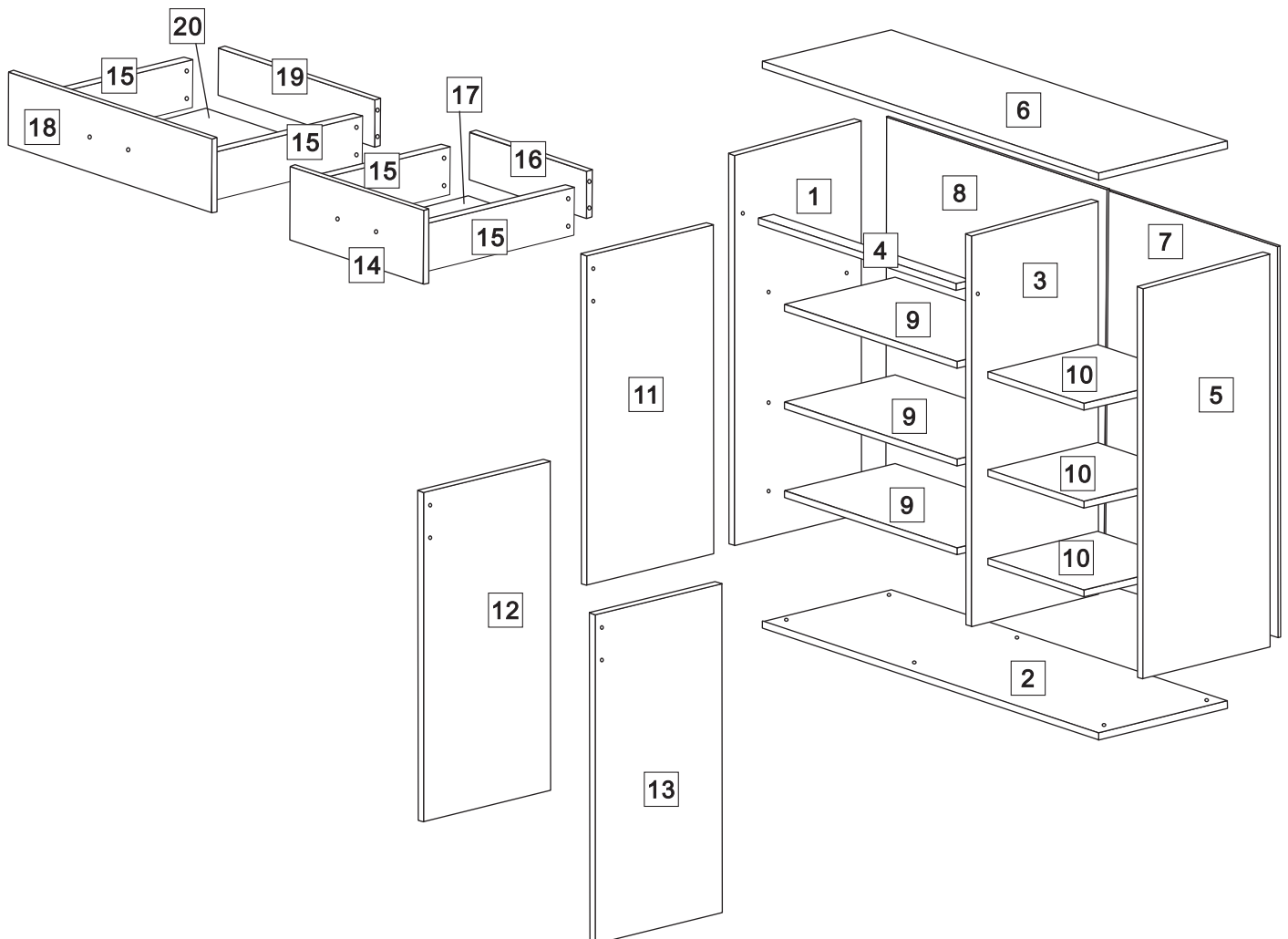

Components - Panels

Please check that you have all the components listed below before constructing your item.

Part No	Description	Qty	Thickness (mm)
1	Left Side panel	1	15 mm
2	Bottom Panel	1	15 mm
3	Centre Panel	1	15 mm
4	Stretcher	1	15 mm
5	Right Side Panel	1	15 mm
6	Top Panel	1	25 mm
7	Back Panel (Small)	1	3 mm
8	Back Panel (Big)	1	3 mm
9	Shelf Panel (Big)	3	15 mm
10	Shelf Panel (Small)	3	15 mm
11	Left Door Panel	1	15 mm
12	Centre Door Panel	1	15 mm
13	Right Door Panel	1	15 mm
14	Drawer Front Panel (Small)	1	15 mm
15	Drawer Side Panel	4	15 mm
16	Drawer Back Panel (Small)	1	15 mm
17	Drawer Base Panel (Small)	1	3 mm
18	Drawer Front Panel (Big)	1	15 mm
19	Drawer Back Panel (Big)	1	15 mm
20	Drawer Base Panel (Big)	1	3 mm











Important-Please read these instructions fully before starting assembly

Components - Fixings

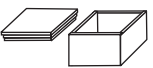
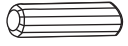
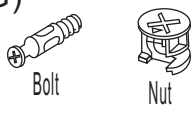
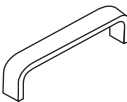

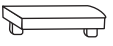
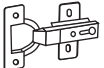
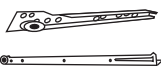

Please check that you have all the components listed below before constructing your item.

Note: The quantities below are the correct amount to complete the assembly. In some cases more fittings may be supplied than are required.

HARDWARE

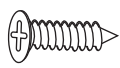
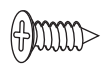
(A)  JCBC M5 X 40mm 8 pcs	(B)  M4 X 32mm 8 pcs	(C)  M3.5 X 14mm 68 pcs	(D)  Nail 52 pcs	(E)  Plastic Leg 5 pcs
(F)  Wood Dowel (M8X25) 10 pcs	(G)  Bolt Nut Mini Fit Set 4 sets	(H)  Handle 5 pcs	(I)  Flat Head Bolt 10 pcs	(J)  Door Stopper 1 pc
(K)  Hinges 6 sets	(L)  Drawer Slide 2 sets	(M)  Plastic Shelf Support Stud 24 pcs	(N)  L-Bracket 2 pcs	(O)  Allen Key 1 pc

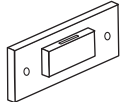
ANTI - TIPPING KITS

(P)  M4 X 32mm 4 pcs	(Q)  M3.5 X 20mm 4 pcs	(R)  Wall Plug 4 pcs	(S)  Bracket 4 pcs	(T)  Cable Tie Strap 2 pcs
--	--	--	--	--

Tools Required (Not Provided)

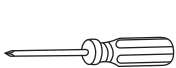

⊕ Screw Driver

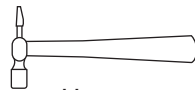

Hammer

Ruler - Use this to measure your screws (mm)

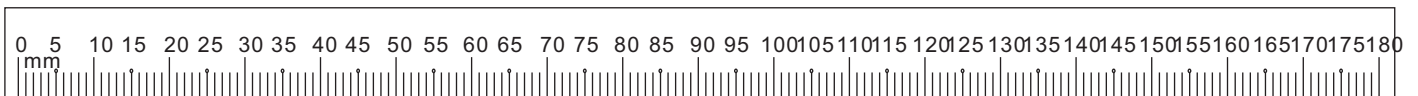

Important-Please read these instructions fully before starting assembly

Assembly Instructions

Step 1 Attach drawer slide rail (L) to Panel boards 1, 3 & 5 with screw (C) onto the specific pre-drilled pilot holes as shown below.

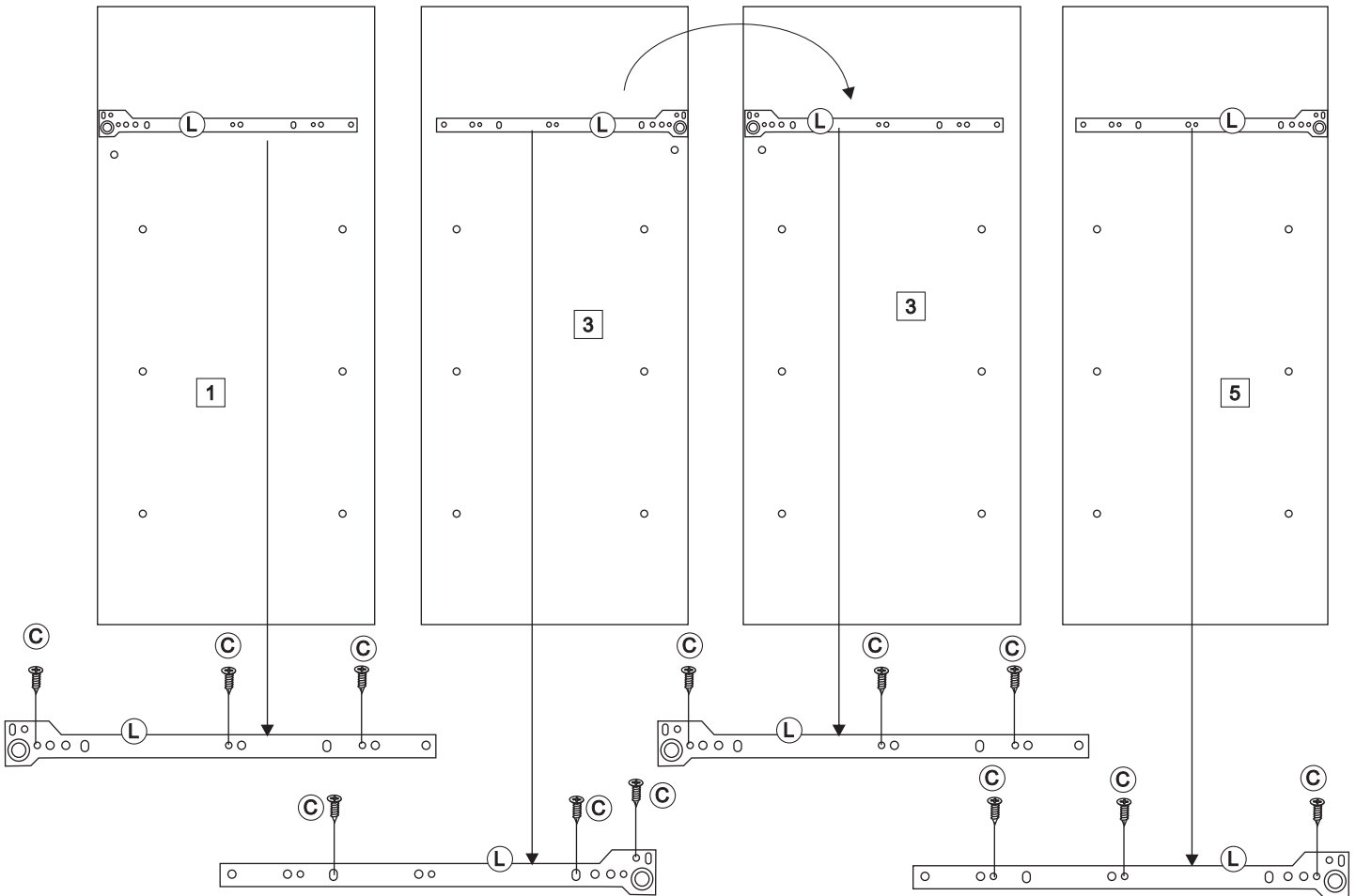

Step 2

Step 2a

Attach minifit bolt (G) to Drawer front panel 14 & 18

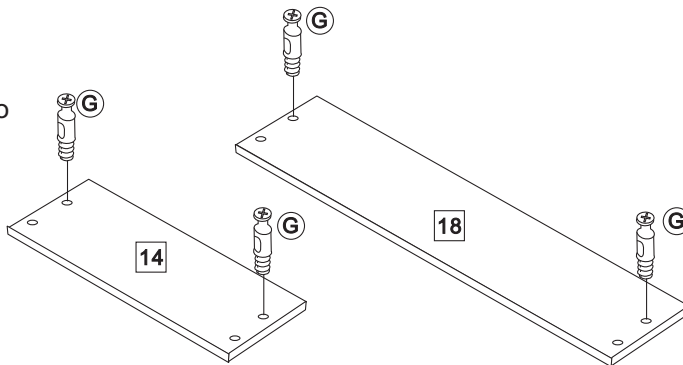

Step 2b

Attach Dowel (F) and Minifit Nut (G) to drawer side panel 15 as shown.

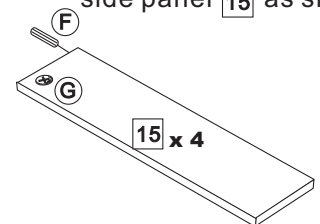

Step 3

Step 3a Attach Handle (H) to drawer front panel 14 with Bolt (I)

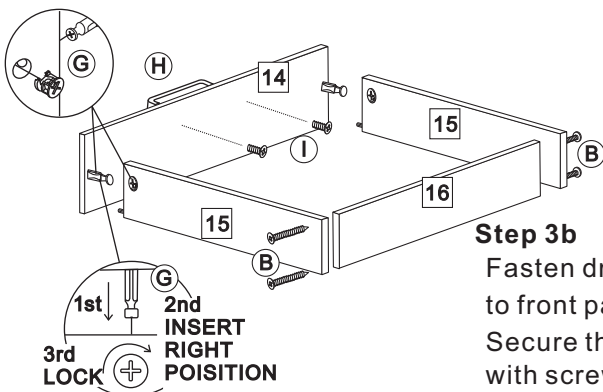

Step 3b

Fasten drawer side panel 15 to front panel 14 with minifit. Secure the drawer back panel 16 with screw (B) using a screw driver.

Step 3c

Attach base board 17 with nail (D) to the drawer base using a small hammer.

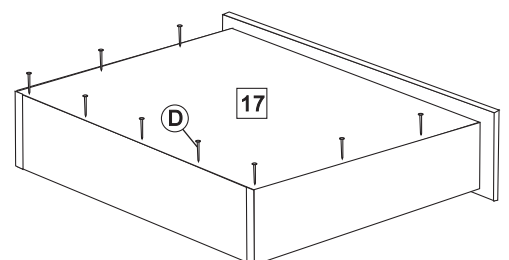

Step 4 Step 4a Attach Handle **G** to drawer front panel **18** with Bolt **I**

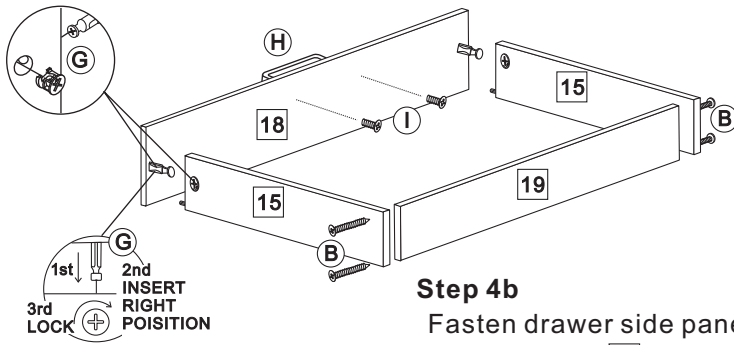

Step 4b

Fasten drawer side panel **15** to front panel **18** with minifit. Secure the drawer back panel **19** with screw **B** using a screw driver.

Step 4c

Attach base board **20** with nail **D** to the drawer base using a small hammer.

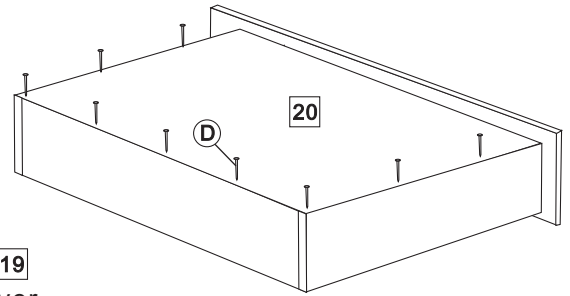

Step 5

5a. Insert Dowel **F** to pre-drilled holes in Panel **1**, **3** & **5**

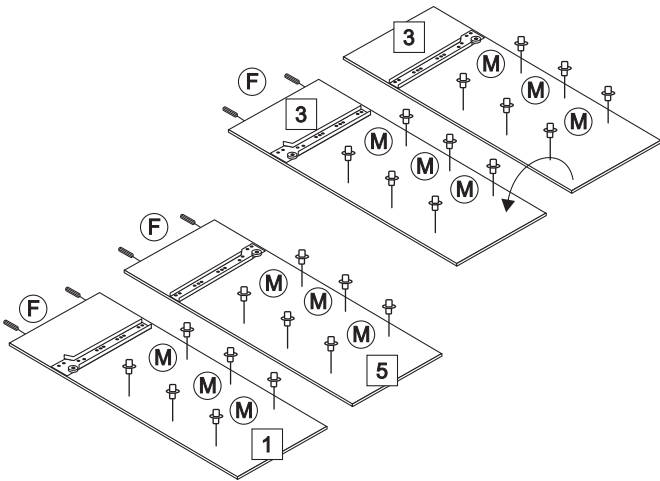

5b. Attach Shelf support stud **M** onto the pre-drilled holes of Panel **1**, **3** & **5**.

Step 6

Attach drawer slide rail **L** to drawer base with screw **C** and tighten with screw driver.

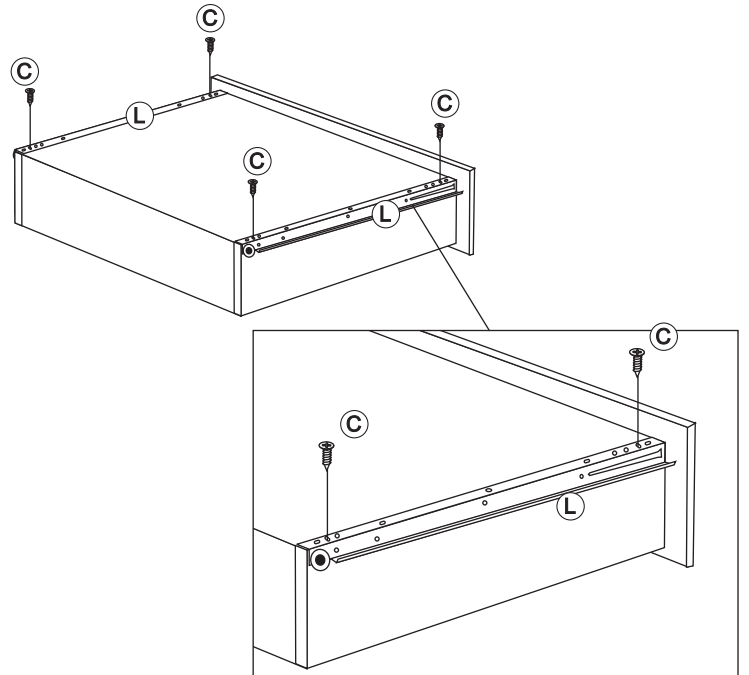

Step 7

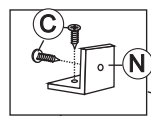

7b. Attach Top panel **6** using L-Bracket **N** with Screw **C**

7a. Attach Panel **1**, **2**, **3**, **4** & **5** with Screw **A** using Allen key **O** to tighten.

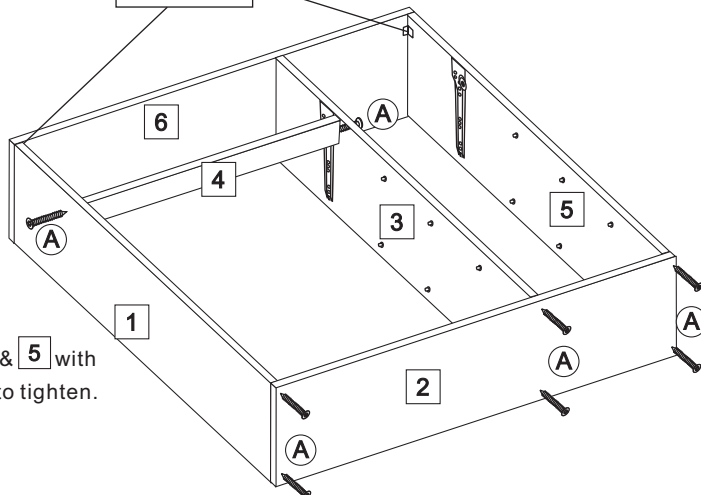

Step 8

8a. Attach back board **7** & **8** to the back of cabinet, with Nail **D** using a hammer.

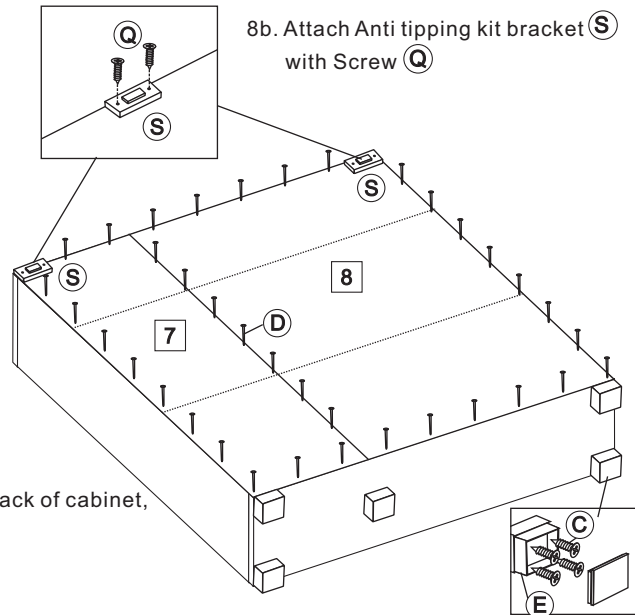

8b. Attach Anti tipping kit bracket **S** with Screw **Q**

8c. Attach Leg **E** with screw **C** as shown.

Step 9

9a. Install Door hinges **K** with Screw **C** using Screw driver to tighten.

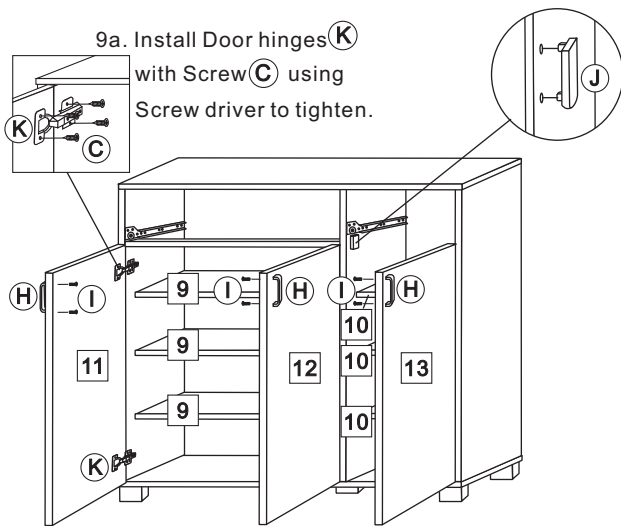

Step 10

Slide assembled Drawer unit into place.

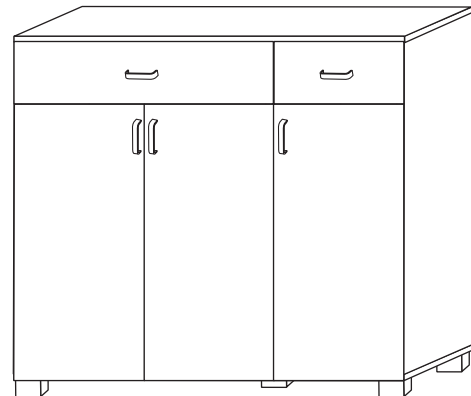

Step 11

Attach the Anti-Tipping kit to the wall, following the steps as shown.

