

NOOK SET NATURAL
DÉJEUNER NATUREL
ESQUINERO NATURAL

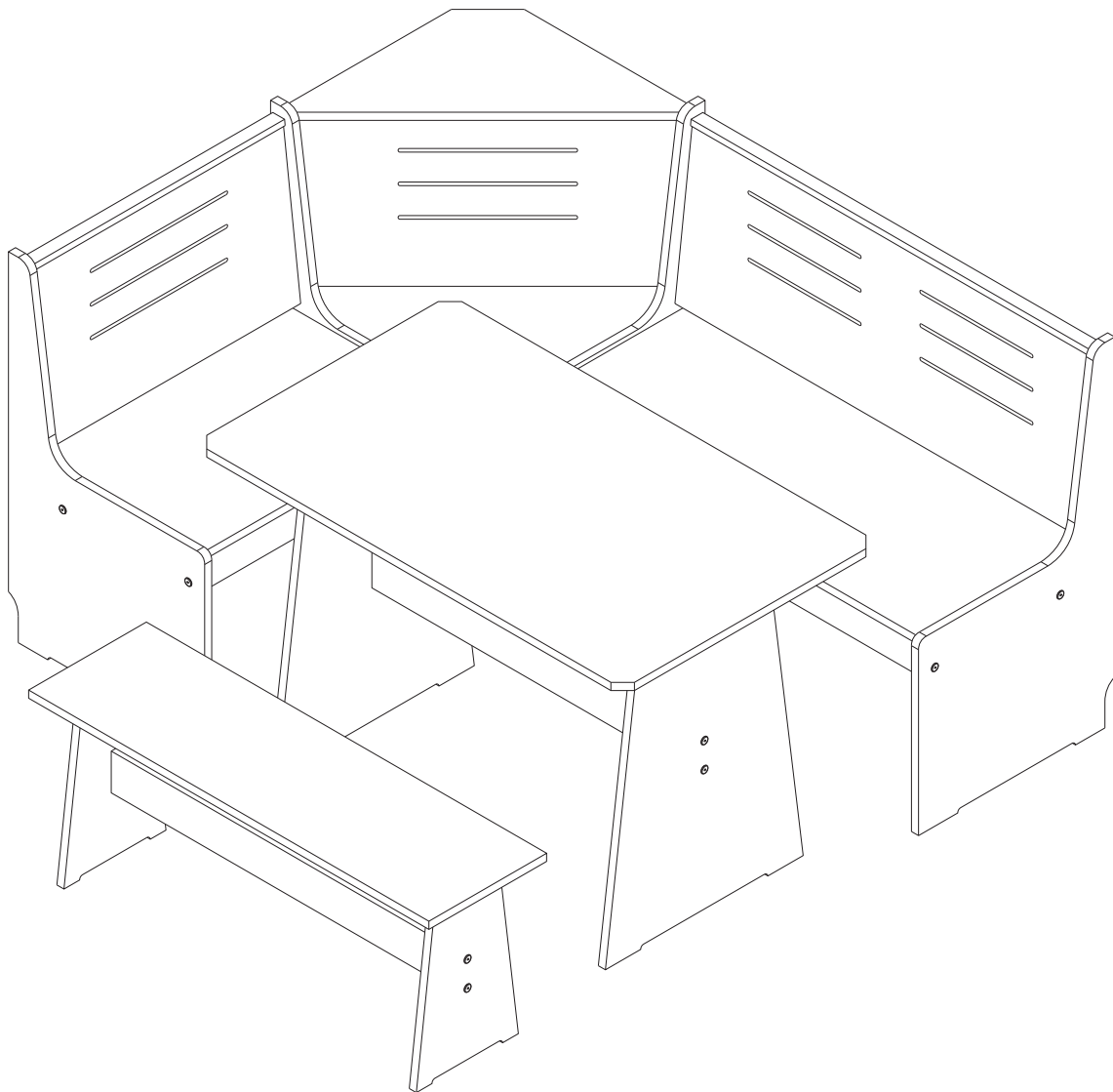

We are here to help!

Before you return it - contact us.

We do our best to insure that your furniture arrives in excellent condition. In the event that a part is damaged or missing, Linon will be happy to provide you with replacement parts, at no charge, within 30 days of purchase, providing the parts are available in our warehouse and the item purchased is part of our current inventory. In order to receive spare parts, at no charge, you must provide proof of purchase within 30 days.

If you need assistance with assembly or replacement parts, please call Customer Service, prior to returning the item to the store.

Nous sommes là pour vous aider!

Avant de retourner le produit, veuillez communiquer avec nous.

Nous faisons tout en notre pouvoir pour que vous receviez votre meuble en parfait état. Toutefois, si une pièce est endommagée ou manquante, Linon se fera un plaisir de vous envoyer gratuitement la pièce de rechange, dans les 30 jours suivant l'achat, à condition que nous ayons la pièce en stock et que le produit acheté fasse partie de notre inventaire courant. Afin de recevoir gratuitement la pièce de rechange, vous devez fournir une preuve d'achat dans un délai de 30 jours.

Si vous avez besoin d'une pièce de rechange ou d'aide pour l'assemblage, veuillez communiquer avec le Service à la clientèle de avant de retourner le produit au magasin.

¡Estamos aquí para ayudarle!

Antes de regresar el producto, comuníquese con nosotros.

Hacemos todo lo posible para que su mobiliario se le entregue en excelentes condiciones. En caso de que falte una pieza o esté dañada, Linon le enviará con gusto la pieza de repuesto sin ningún costo dentro de los 30 días posteriores a la compra, siempre y cuando tengamos en existencia las piezas en nuestros almacenes y que el artículo comprado forme parte de nuestro inventario actual. Para recibir piezas de repuesto, sin costo adicional, debe enviarnos el comprobante de compra dentro de los 30 días después de la compra.

Si necesita ayuda para ensamblar su producto o para obtener piezas de repuesto, llame al Servicio al Cliente de antes de devolver el artículo a la tienda.

SELECT THE LAYOUT OF THE BENCH

THIS ITEM REVERSIBLE AND CAN BE INSTALLED EITHER WITH THE LARGE BENCH AT YOUR LEFT HAND SIDE (LEFT SIDE INSTALLATION) OR WITH THE LARGE BENCH AT YOUR RIGHT HAND SIDE (RIGHT SIDE INSTALLATION).

THIS INSTRUCTION IS MADE FOR RIGHT HAND INSTALLATION.

IF YOU SELECT THE LEFT HAND INSTALLATION THEN YOU HAVE TO SWITCH ALL THE PARTS LOCATED AT RIGHT PART (07, 08, 12, 15 AND 18) TO LEFT PART AND THE PARTS LOCATED AT LEFT PART (05, 09, 13, 16 AND 19) TO RIGHT PART.

ATTENTION: OUTSIDE LEGS #01 AND #04 PLUS CENTRAL PIECES (02, 03, 06, 10, 11 AND 17) REMAIN UNCHANGED.

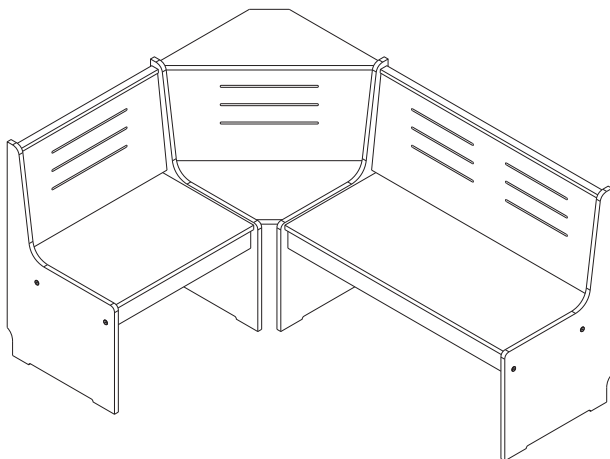

RIGHT SIDE INSTALLATION

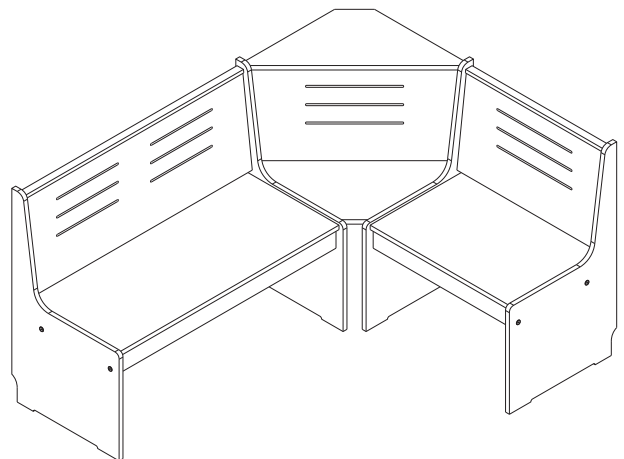

LEFT SIDE INSTALLATION

NOTE: BEFORE STARTING THE ASSEMBLY PROCESS, ALL PARTS SHOULD BE SEPARATED ACCORDING TO THE ITEM THEY BELONG TO. FOR BETTER IDENTIFICATION OF ALL PARTS, PLEASE USE PART IDENTIFICATION LIST ON PAGE 4 FOR THE CORNER BENCH; THE PART IDENTIFICATION LIST ON PAGE 12 FOR THE TABLE; AND ON PAGE 15 FOR THE SIMPLE BENCH.





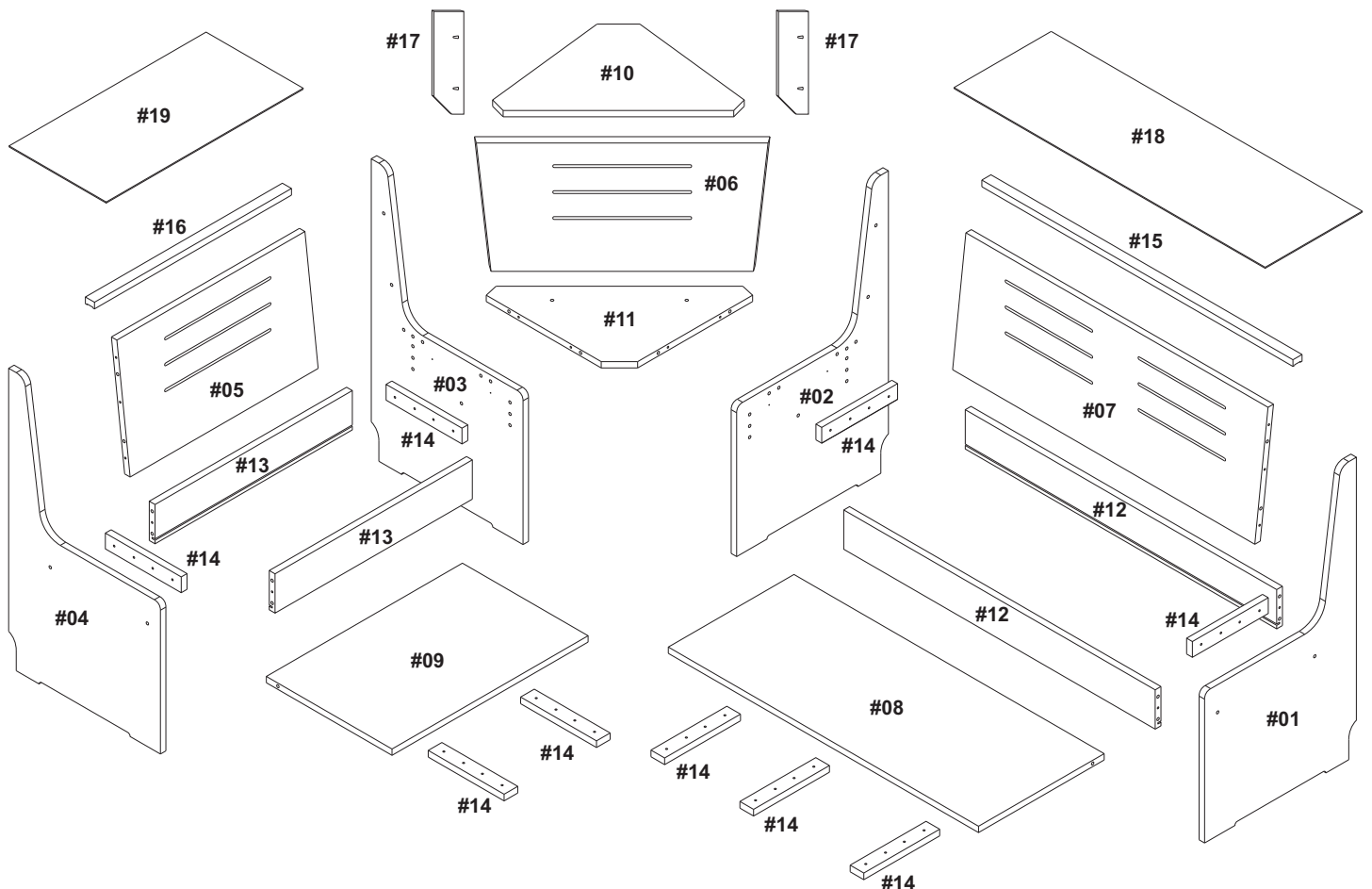

**PART LIST - CORNER BENCH / LISTE DES PIÈCES - BANC D'ANGLE
LISTA DE PIEZAS - BANCO DE ESQUINA**

Description	Qty.
Right side leg / Pied droit / Pata derecha	01
Middle leg right side / Pied centrale droite / Pata derecha central	01
Middle leg left side / Pied centrale gauche / Pata izquierda central	01
Left side leg / Pied gauche / Pata izquierda	01
Small back rest panel / Panneau de dossier petit / Panel de respaldo pequeño	01
Corner back rest panel / Panneau de dossier d'angle / Panel de respaldo de esquina	01
Large back rest panel / Panneau de dossier grand / Panel de respaldo grande	01
Large seat / Grand siège / Asiento grande	01
Small seat / Petit siège / Asiento pequeño	01
Corner top / Supérieur de coin / Superior de la esquina	01
Corner seat / Siège d'angle / Asiento de la esquina	01
Large cross rail / Grand rail transversal / Travesaño grande	02
Small cross rail / Petit rail transversal / Travesaño Pequeño	02
Cleats support / Support de bois / Tacos de apoyo	09
Large top rail / Grand rail supérieur / Riel superior grande	01
Small top rail / Petit rail supérieur / Riel superior pequeño	01
Back supports / Supports dorsaux / Apoyos traseros	02
Large storage bottom panel / Grand panneau inférieur de stockage / Panel inferior de almacenamiento grande	01
Small storage bottom panel / Petit panneau inférieur de stockage / Panel inferior de almacenamiento pequeño	01
Nook Hardware Pack / Ferrures / Paquete de Herraje	01

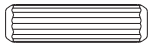
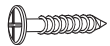

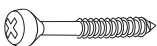
RIGHT SIDE INSTALLATION

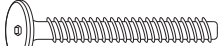
**HARDWARE PACKAGE - CORNER BENCH / PAQUET DE MATÉRIEL - BANC DE COIN
PAQUETE DE HARDWARE - BANCO ESQUINERO**

A	Wood dowel (8x30mm) / Goujons de bois / Tarugo de madera		36
C	Screw (4x25mm) / Vis / Tornillo		06
D	Screw (4x30mm) / Vis / Tornillo		43
E	Screw (4x35mm) / Vis / Tornillo		22
F	Screw (7x50mm) / Vis / Tornillo		04
G	Screw (7x50mm) / Vis / Tornillo		08
H	Plastic Pin / Charnière / Pino		04
I	Allen Wrench / Clé Allen / Llave Allen		01

Tools required / Outils requis / Herramientas requeridas

Philips screwdriver / Tournevis philips / Destornillador estándar		Not supplied / Non fourni / No incluido
--	--	--

IMPORTANT:

1. Do not tighten bolts completely until all bolts are completely lined up and inserted into holes / nuts.
2. Do not over tighten screws and bolts to avoid stripping.
3. Please use hand tools to assemble this product. Do not use power tools.

IMPORTANT:

1. Ne serrez pas complètement les boulons jusqu'à ce que tous les boulons soient complètement alignés et insérés dans les trous / écrous.
2. Ne pas trop serrer les vis et les boulons pour éviter d'endommager les filets.
3. Utilisez des outils à main pour assembler ce produit. N'utilisez pas d'outils électriques.

IMPORTANTE:



1. No apriete completamente los pernos hasta que todos los tornillos estén alineados completamente y se inserten en los agujeros / tuercas.
2. No apriete demasiado los tornillos y los pernos para evitar dañar los filetes.
3. Utilice herramientas de mano para montar este producto. No utilice herramienta

1.

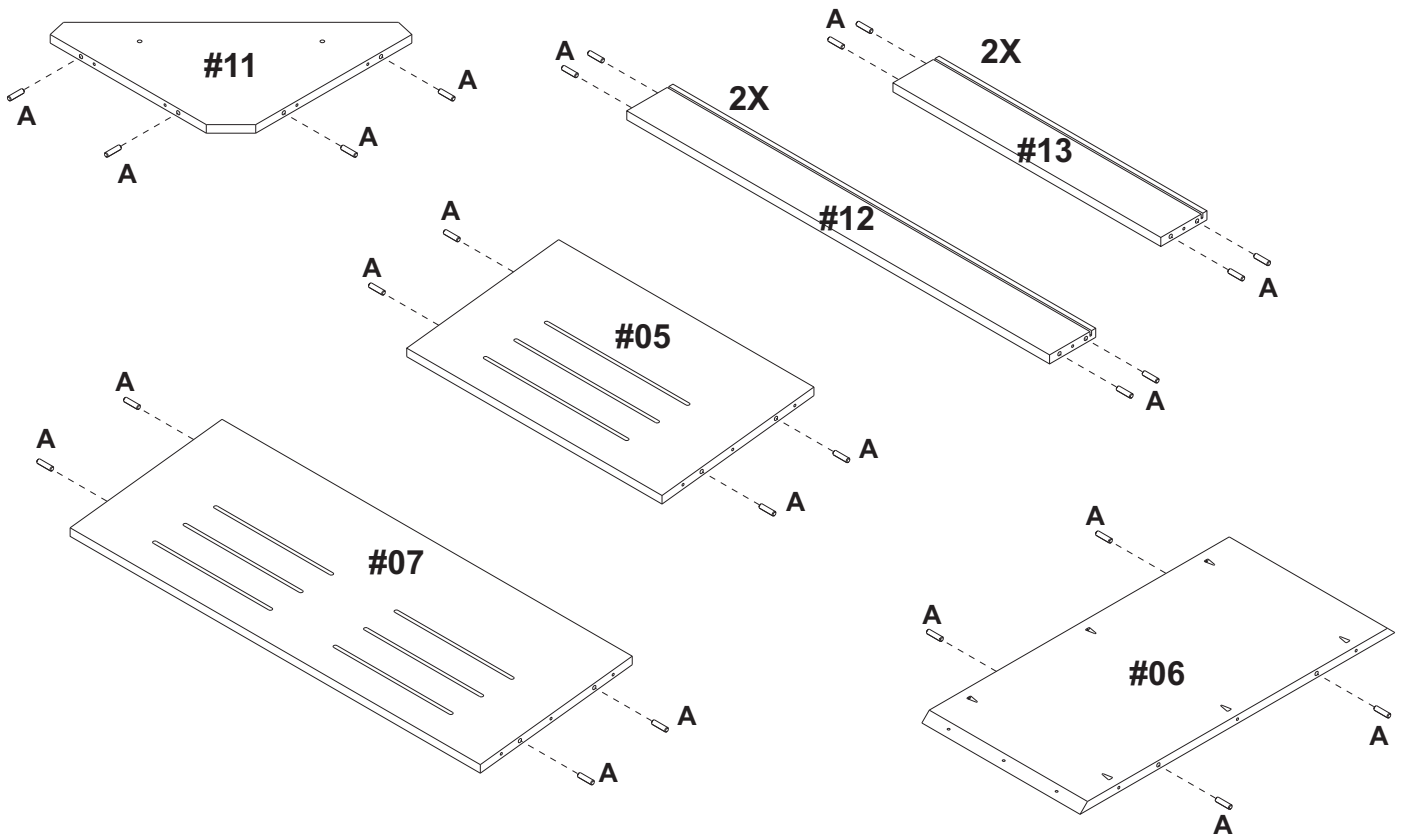
A		32
---	---	----



2.

A		04
H		04

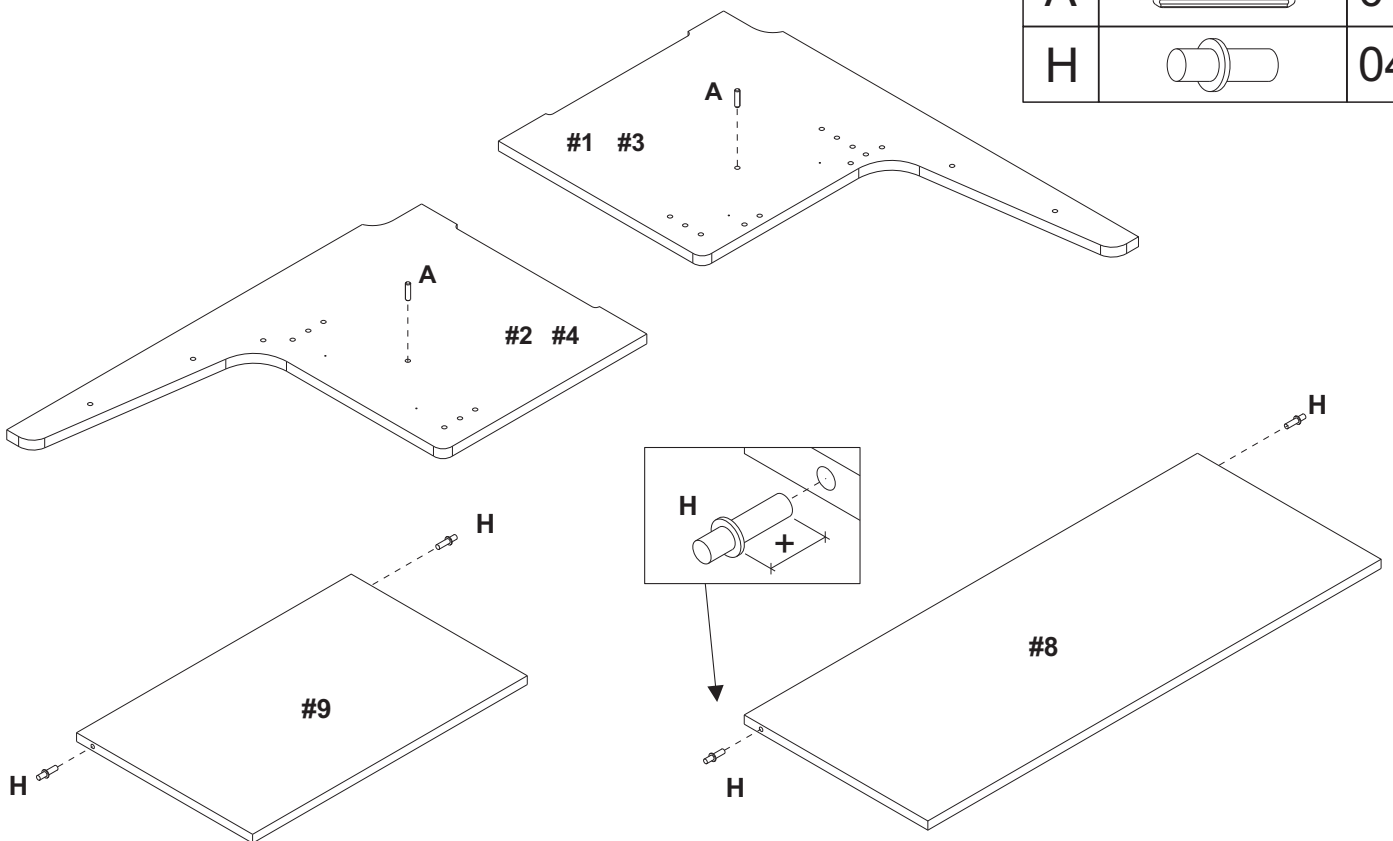

3.

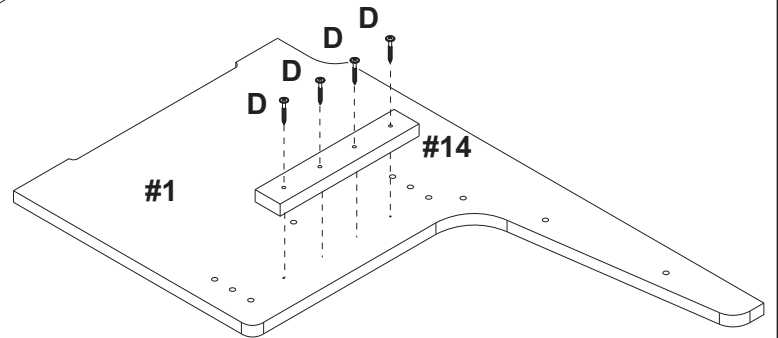
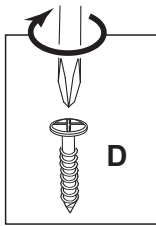
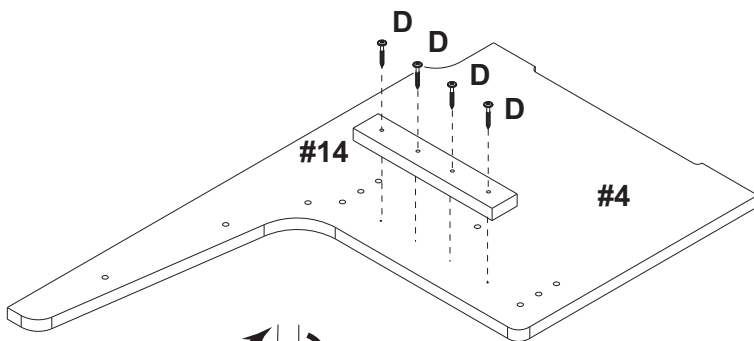
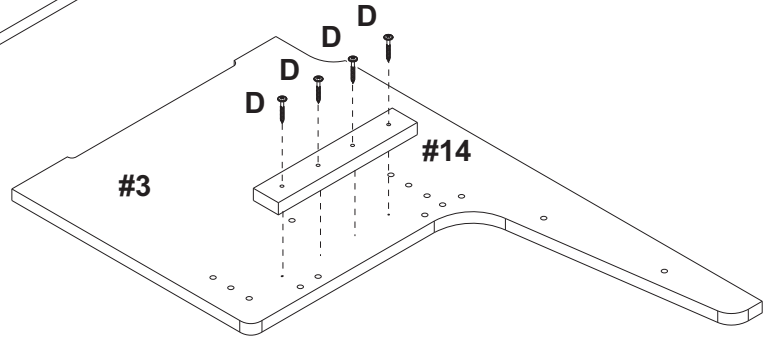
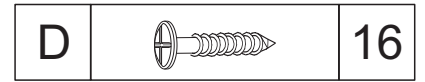
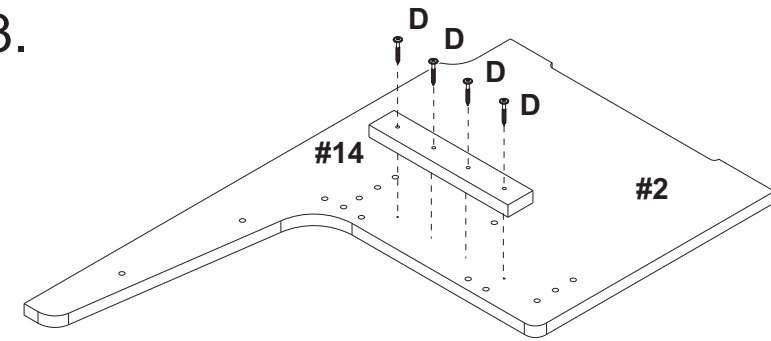

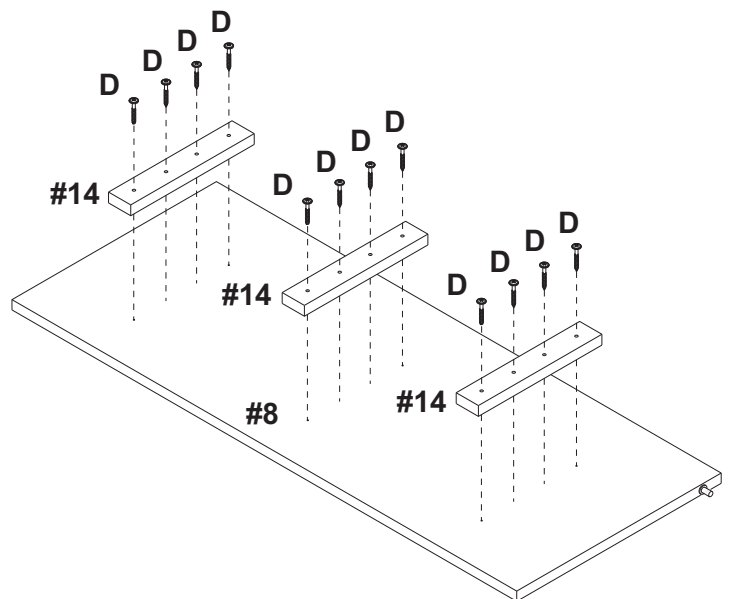
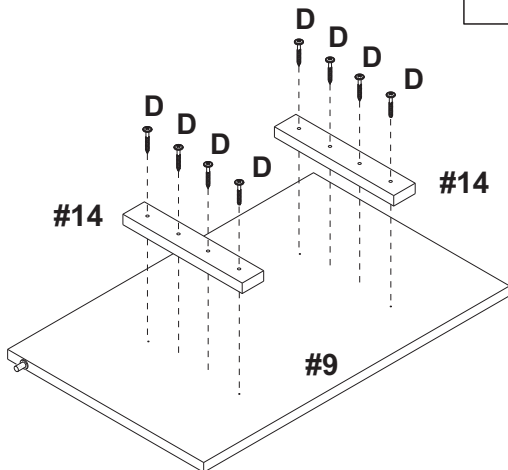
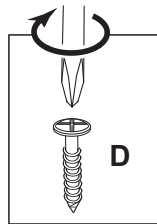
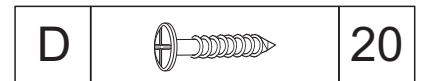

4.



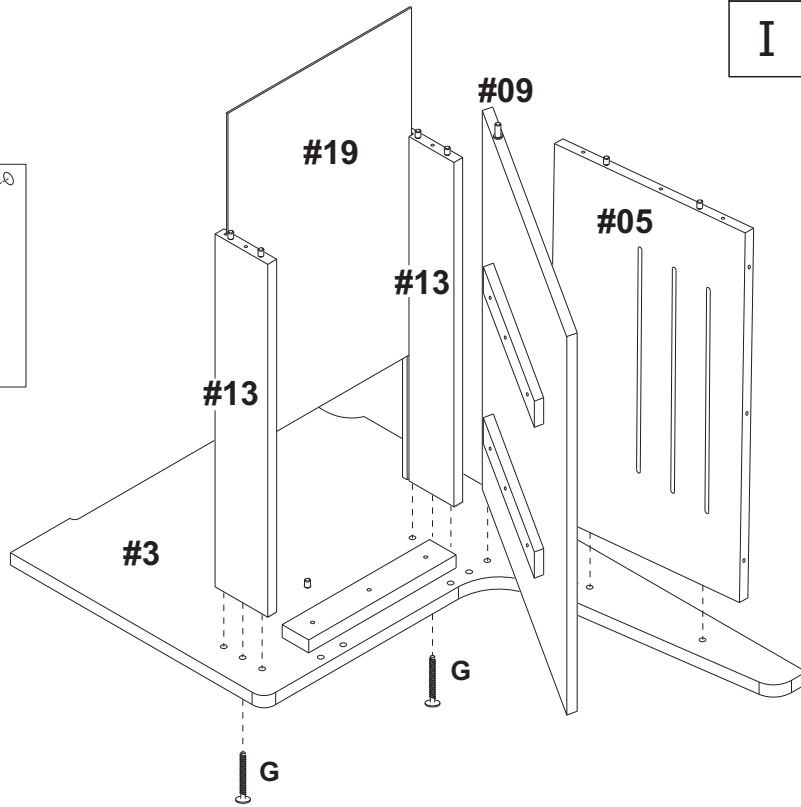
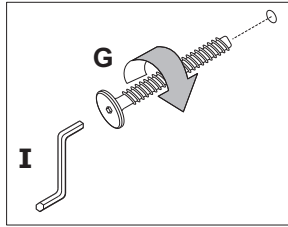

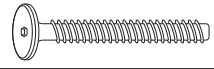
5.

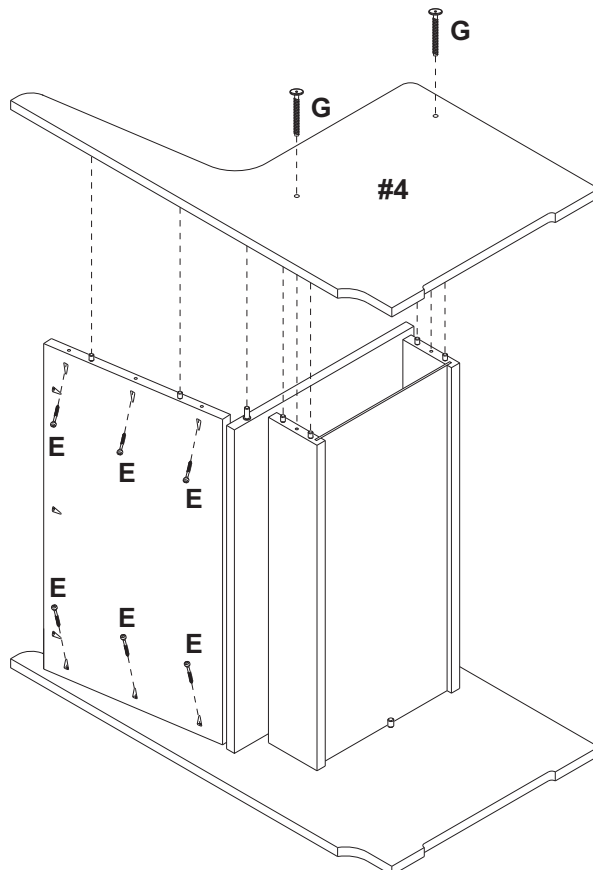
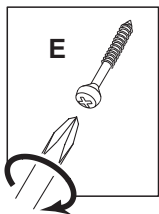

G		02
I		01

6.

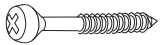
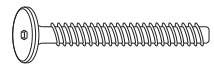

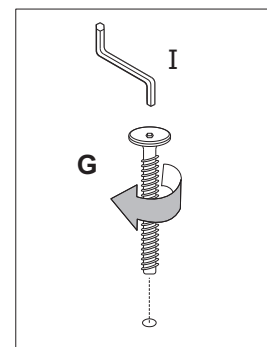

E		06
G		02
I		01



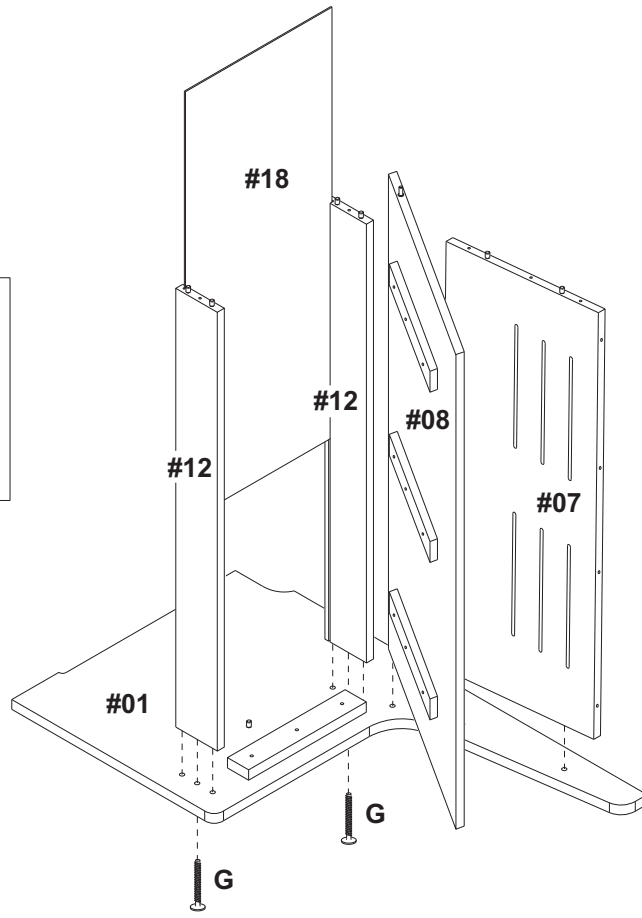
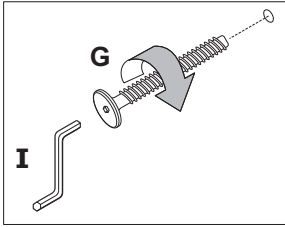

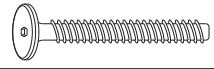
7.



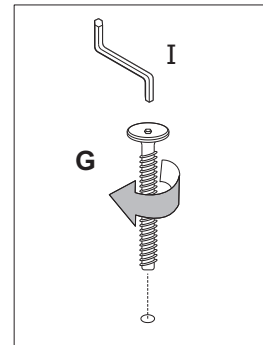
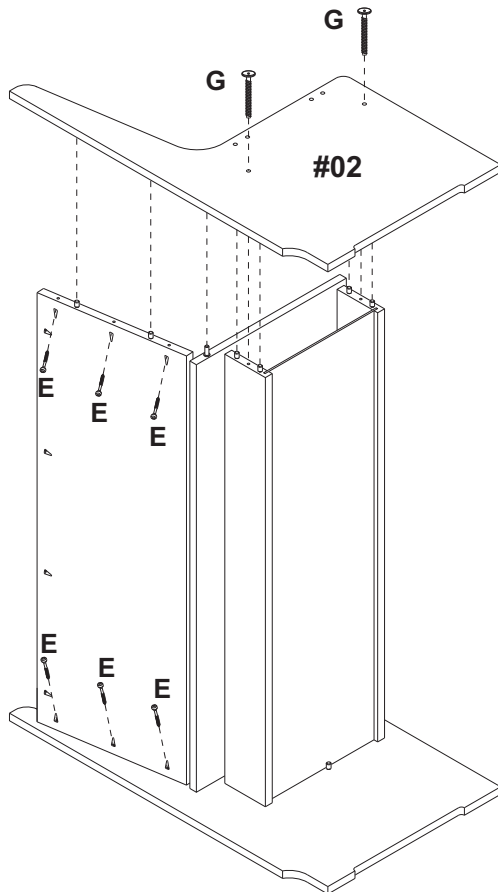
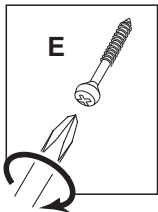

G		02
I		01

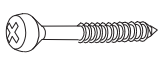
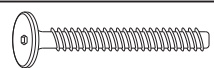
8.

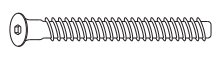

E		06
G		02
I		01

9.

F		04
I		01

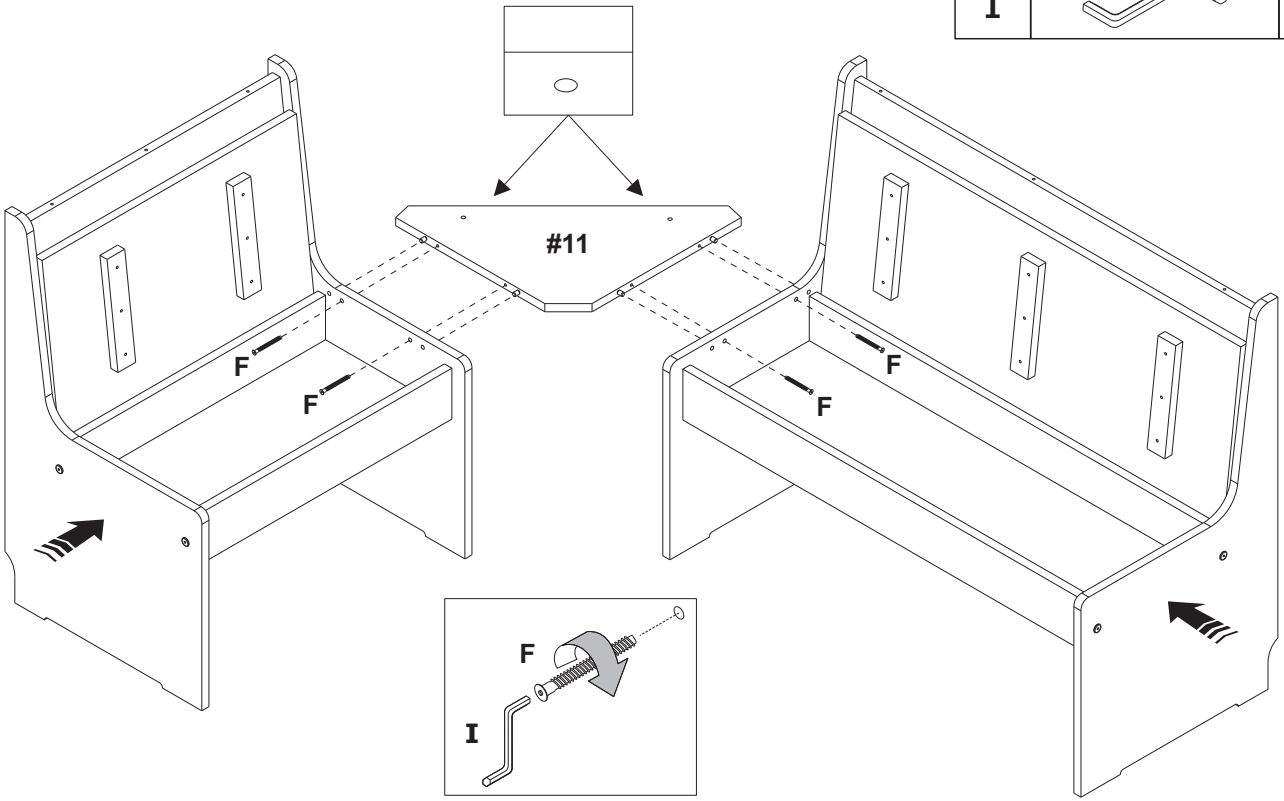

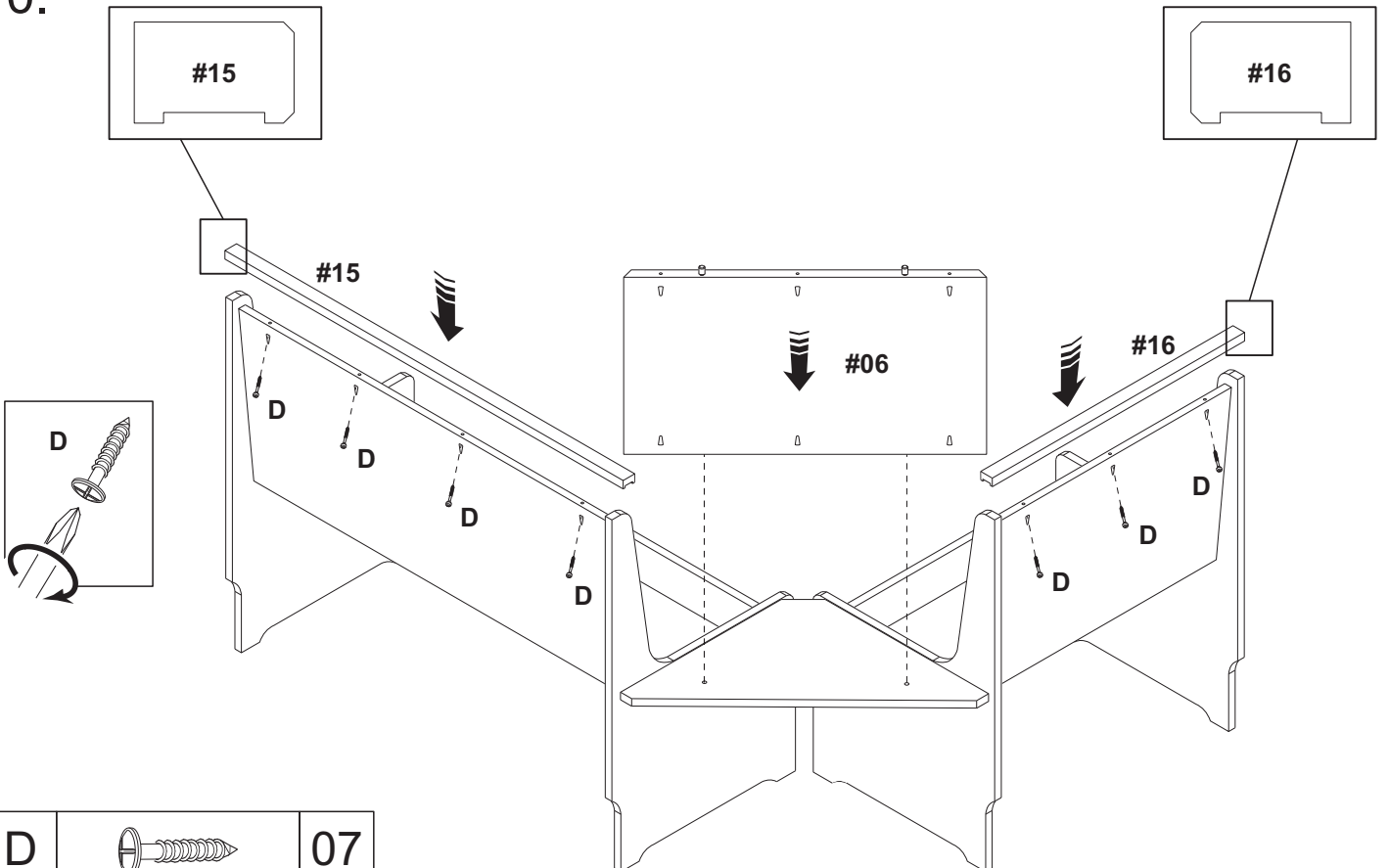

10.

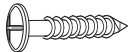

D		07
---	---	----

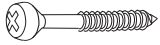
11.

E		06
C		06

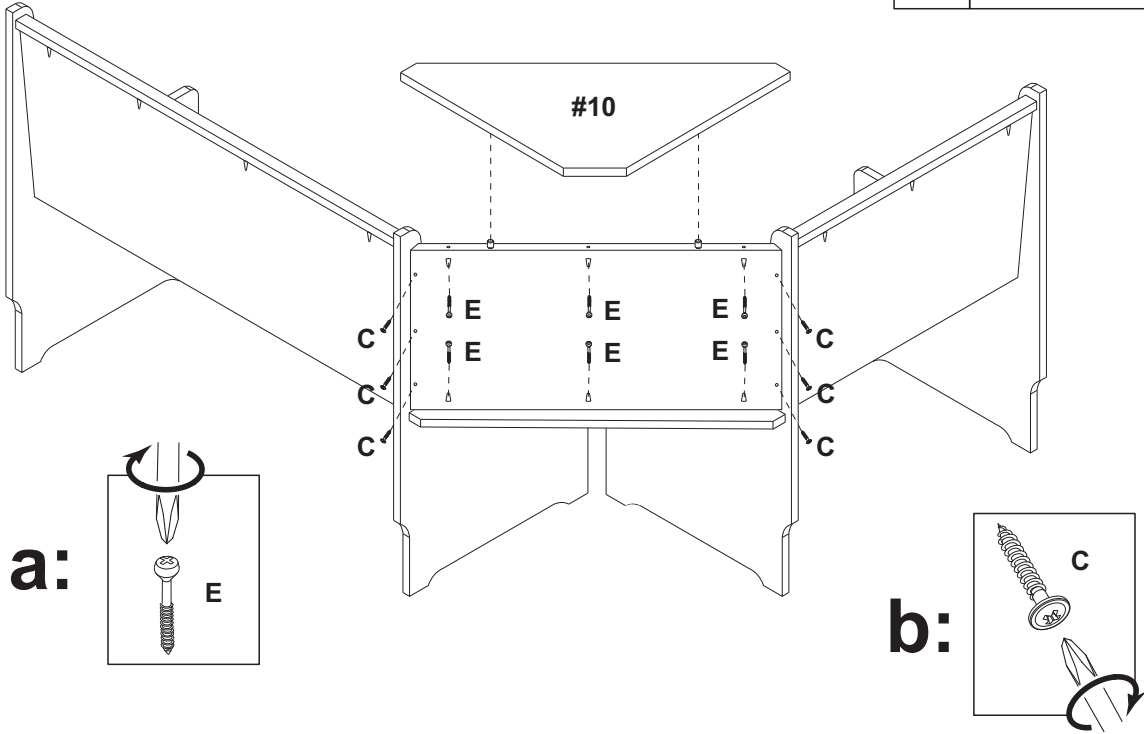

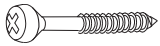

12.

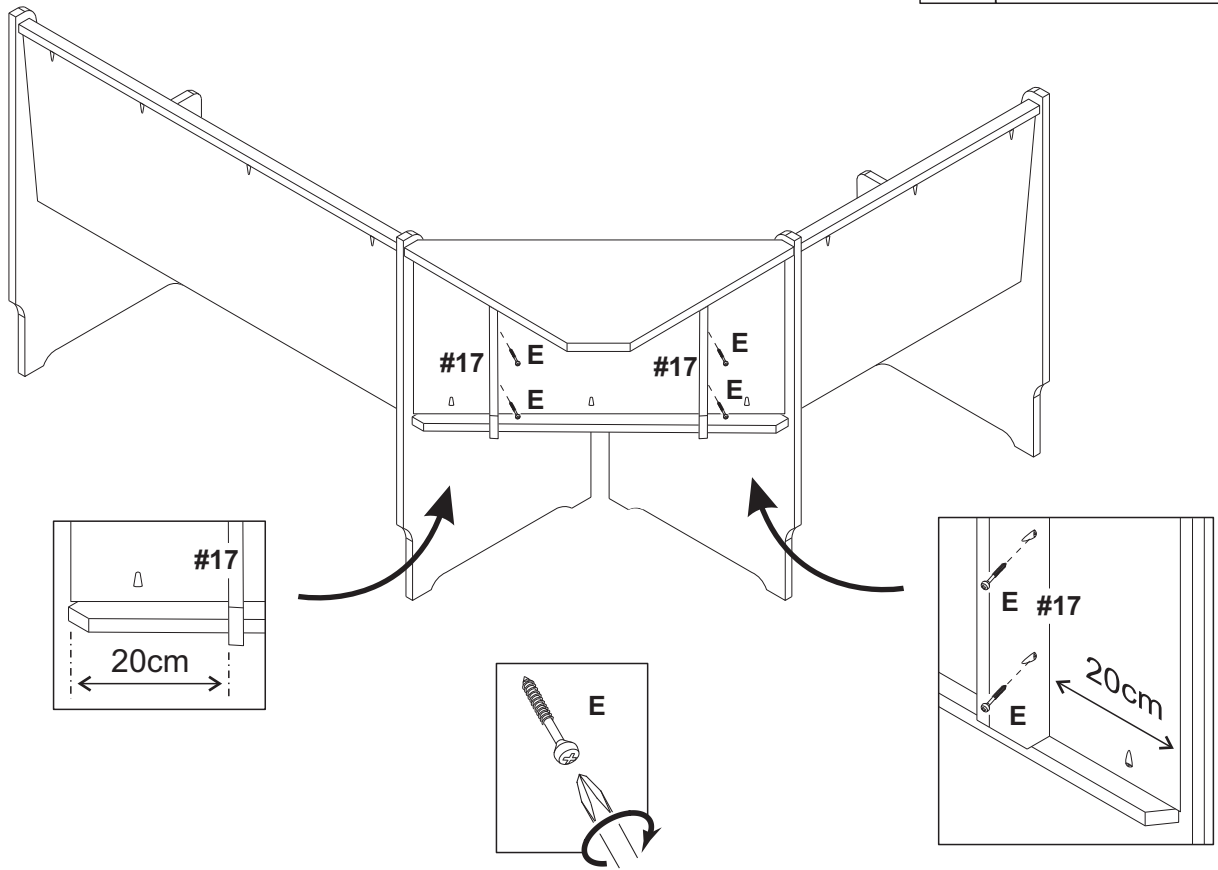
E		04
---	---	----

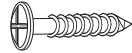
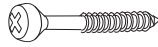
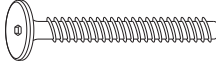

HARDWARE PACKAGE - TABLE / PAQUET DE MATÉRIEL - TABLE
PAQUETE DE HARDWARE - MESA

B	Wood dowel (8x50mm) / Goujons de bois / Tarugo de madera		04
D	Screw (4x30mm) / Vis / Tornillo		08
E	Screw (4x35mm) / Vis / Tornillo		06
G	Screw (7x50mm) / Vis / Tornillo		04
I	Allen Wrench / Clé Allen / Llave Allen		01

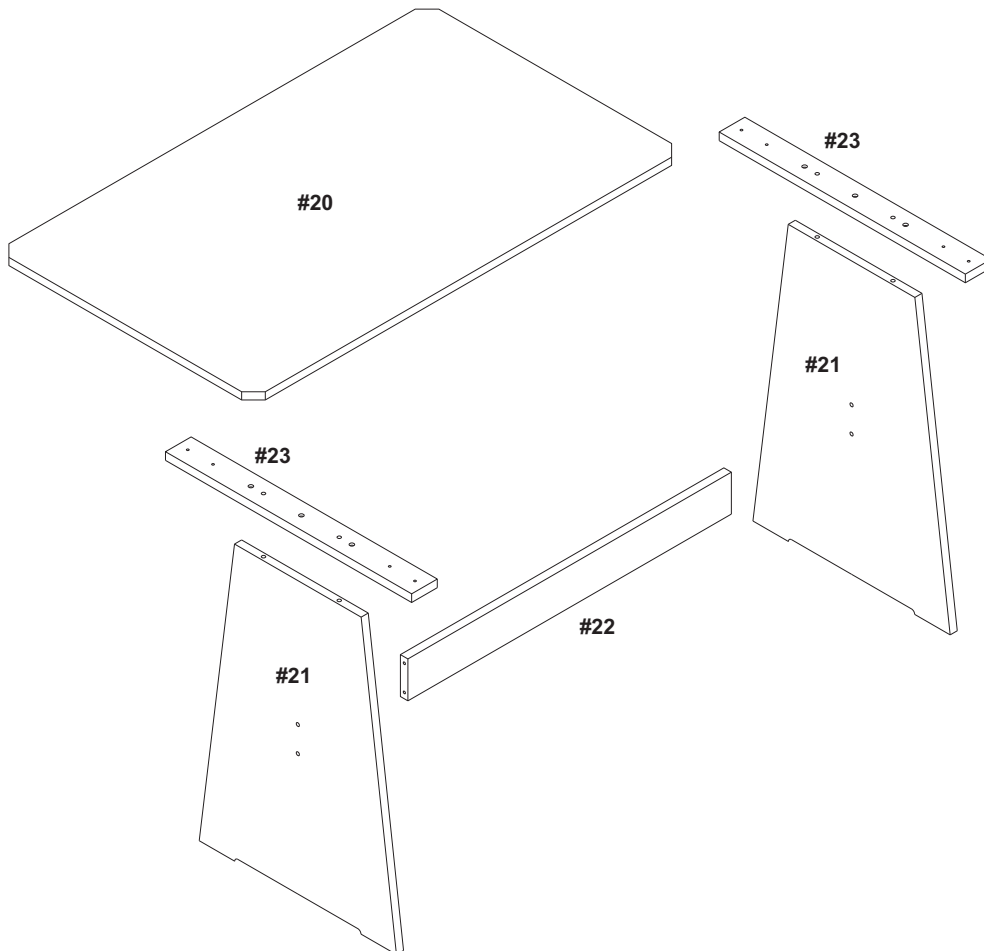

PART LIST TABLE - TABLE / LISTE DES PIÈCES - TABLE
LISTA DE PIEZAS - MESA

Description	Qty.
Table top / Dessus de la table / Tablero de mesa	01
Table legs / Pieds de table / Patas de mesa	02
Crossbar / Barre transversale / Travesaño	01
Table top supports / Supports de table / Soportes de mesa	02
Table Hardware Pack / Ferrures / Paquete de Herraje	01



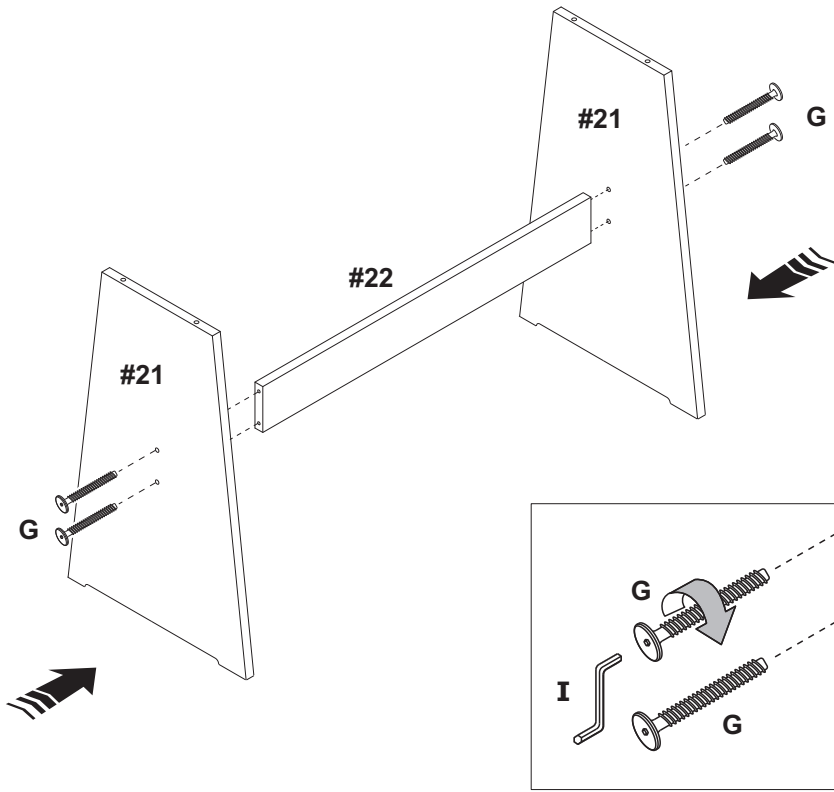

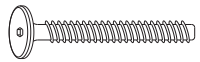
1.

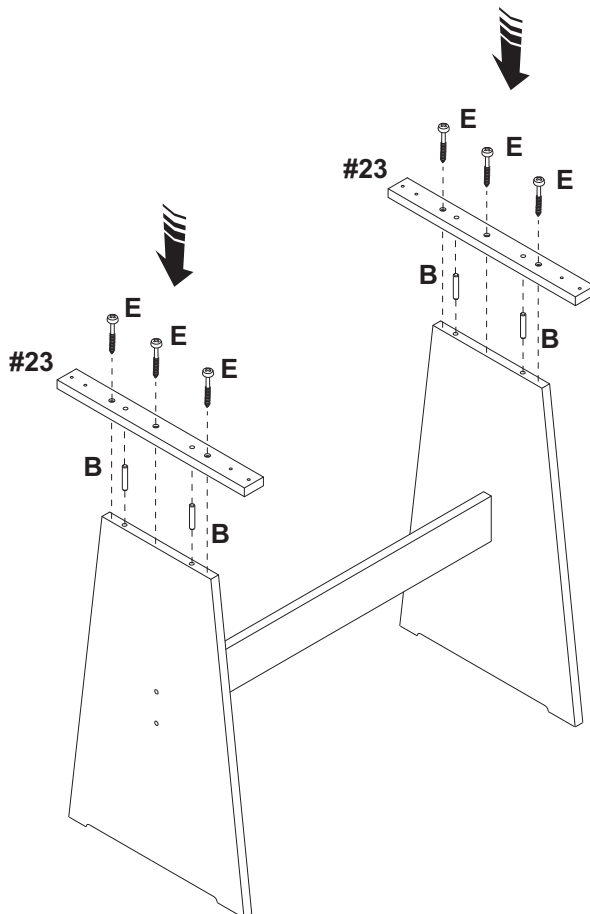

G		04
I		01

2.

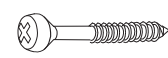

B		04
E		06

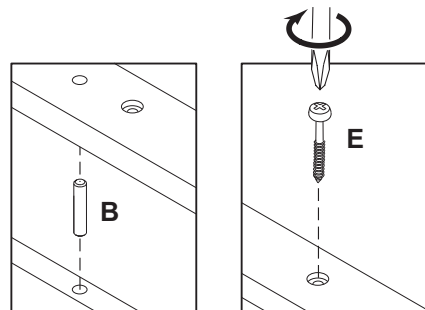

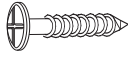

3.

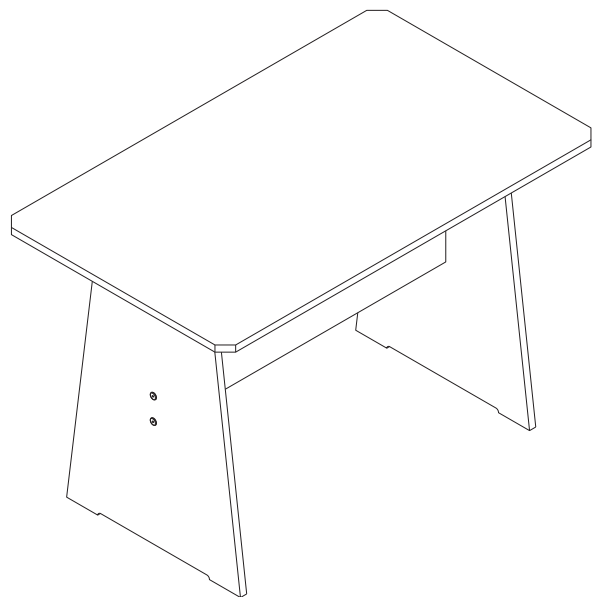
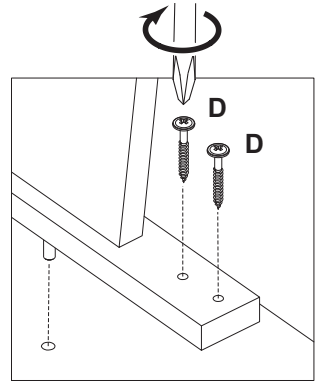
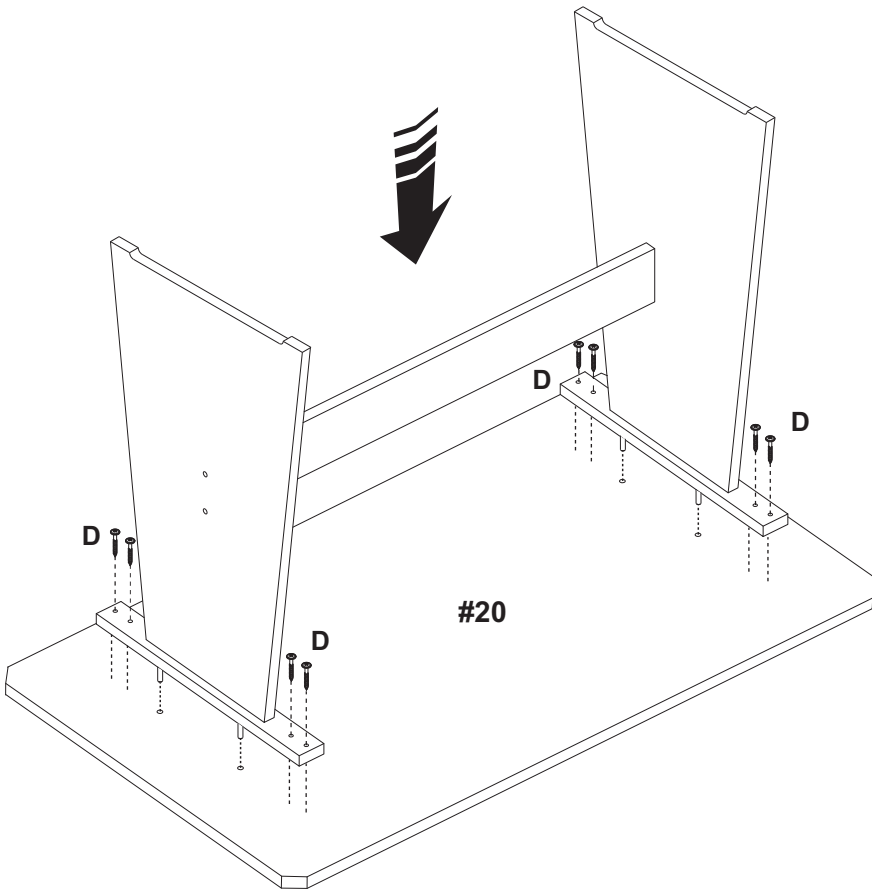
D		08
---	---	----

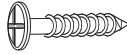
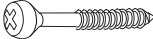
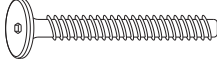

HARDWARE PACKAGE TABLE - SIMPLE BENCH - / PAQUET DE MATÉRIEL - BANC SIMPLE
PAQUETE DE HARDWARE - BANCO SIMPLE

B	Wood dowel (8x50mm) / Goujons de bois / Tarugo de madera		04
D	Screw (4x30mm) / Vis / Tornillo		04
E	Screw (4x35mm) / Vis / Tornillo		04
G	Screw (7x50mm) / Vis / Tornillo		04
I	Allen Wrench / Clé Allen / Llave Allen		01

PART LIST - SIMPLE BENCH / LISTE DES PIÈCES - BANC SIMPLE
LISTA DE PIEZAS - BANCO SIMPLE

Description	Qty.
Bench seat / Siège / Asiento	01
Bench legs / Pieds de banc / Patas de banco	02
Crossbar / Barre transversale / Travesaño	01
Bench top supports / Supports de banc / Soportes de banco	02
Simple Bench Hardware Pack / Ferrures / Paquete de Herraje	01

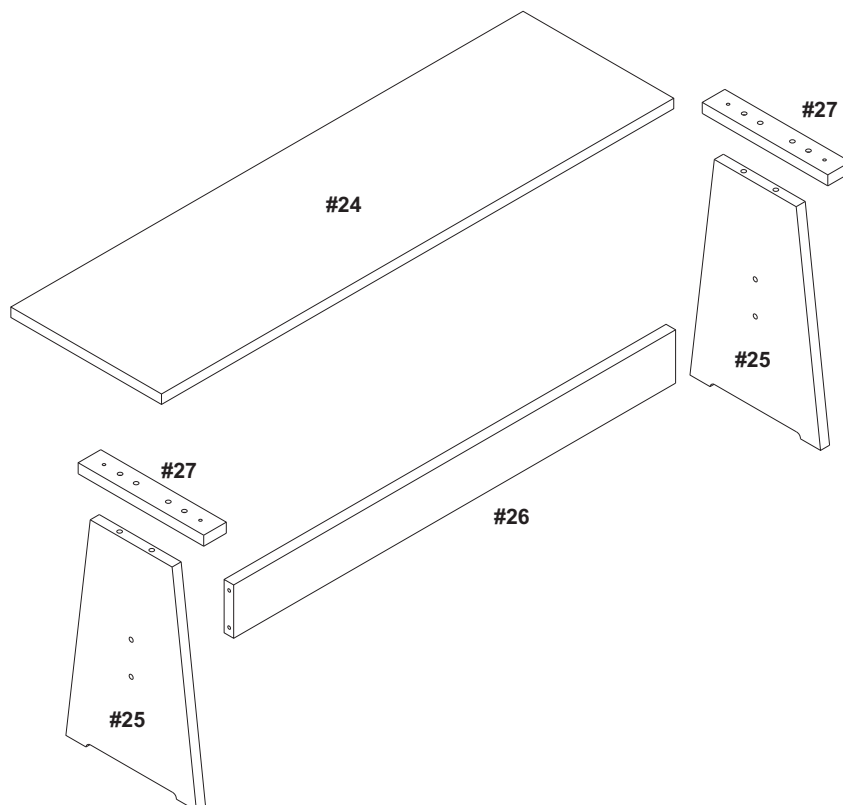

1.

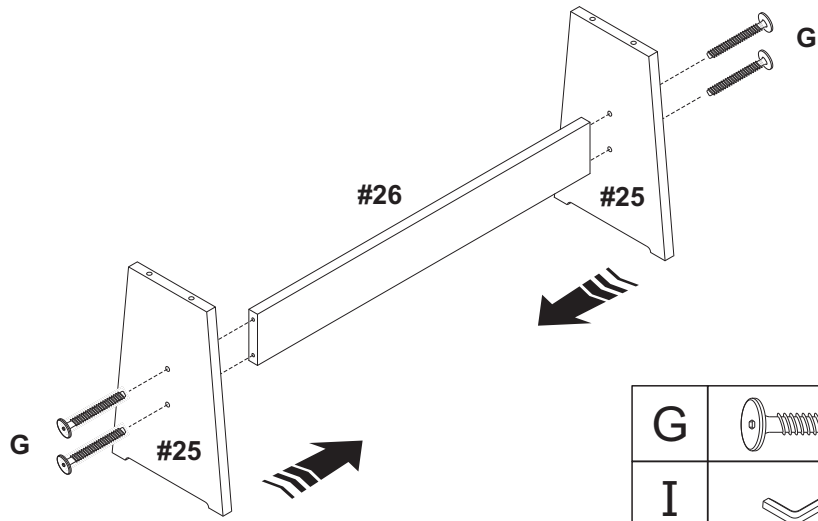
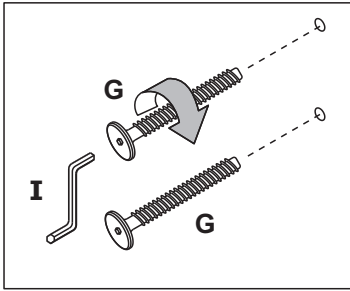

G		04
I		01

2.

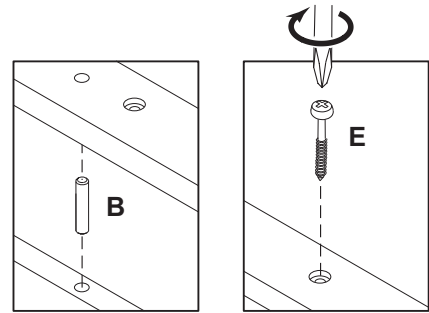
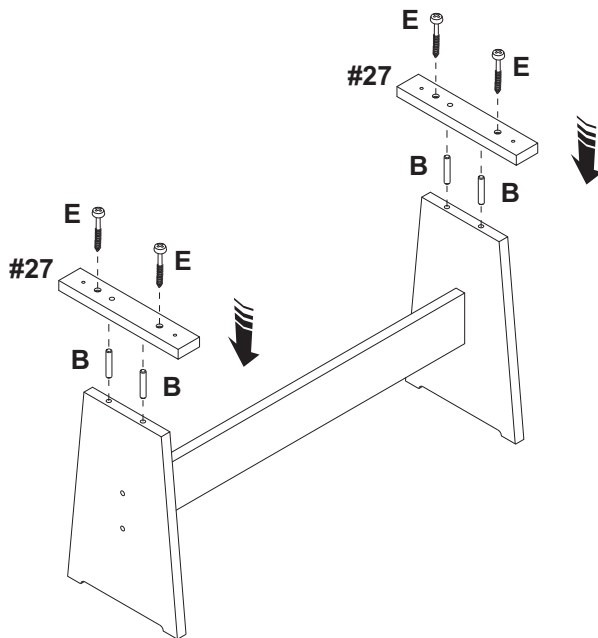

B		04
E		04

3.

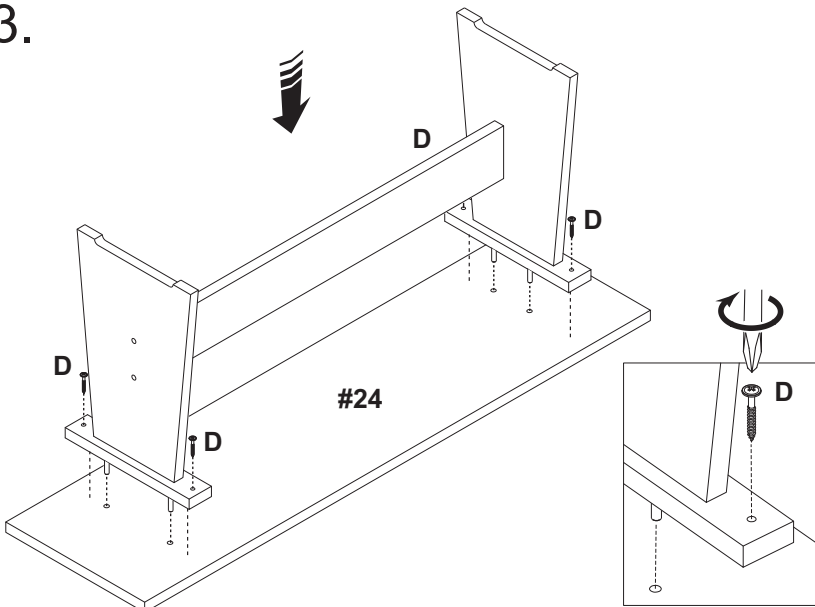

D		04
---	--	----

LIMITED 6 MONTHS WARRANTY

GARANTIE LIMITÉE DE 6 MOIS

GARANTÍA LIMITADA DE 6 MESES

WHAT IS COVERED

This product is covered under our manufacturer's 6 months limited warranty. To ensure your complete satisfaction, this warrants to the original purchaser that the supplied item is free from defects in material and workmanship, as of the date of purchase, and that it will, under normal use and proper care, remain so for six months after the date of purchase.

Replacement of missing or initially defective parts will be sent, at no charge, for a period of 30 days from the date of purchase with valid proof of purchase providing the parts are available in our warehouse and the item purchased is part of our current inventory.

WHAT IS NOT COVERED

It remains the customer's responsibility for freight and packaging charges to and from the customer service center. Labor and material charges to remove or replace parts under this warranty are not covered.

This warranty does not cover: Furniture used for commercial purposes, failures caused by improper installation assembly or by improper care, unreasonable or abusive use, freeze damage, acts of God, rust, purchased parts or return freight and packaging charges. Proof of purchase (dated register receipt) is required for warranty claims.

HOW TO OBTAIN SERVICE

For further information, please contact our customer service department

CARE INSTRUCTIONS

- Care and cleaning should be done with a soft cloth and water.
- Do not use abrasive products and steel wool.
- Do not expose the furniture to bad weather or excessive heat.

QU'EST-CE QUI EST COUVERT

Ce produit est couvert sous une garantie limitée de 6 mois offerte par le fabricant. Afin d'assurer votre entière satisfaction, cela garantit à l'acheteur original que le produit fourni est exempt de défauts de matériaux et de fabrication à compter de la date d'achat, et ce, sous des conditions d'utilisation normales et de soins adéquats, valide pendant six mois après la date d'achat.

Le remplacement de pièces manquantes ou défectueuses dès le départ sera envoyé, sans frais, pour une période de 30 jours suivant la date d'achat avec une preuve d'achat valide pourvu que les pièces soient disponibles dans notre entrepôt et que l'article acheté fait partie de notre inventaire actuel.

QU'EST-CE QUI N'EST PAS COUVERT

Il y va de la responsabilité du client de couvrir les frais de transport et d'emballage vers et à partir du centre de service après-vente. Les frais de la main-d'œuvre et des matériaux pour retirer les pièces ou les remplacer sous cette garantie ne sont pas couverts.

Cette garantie ne couvre pas : les meubles utilisés à des fins commerciales, les défaillances causées par un mauvais assemblage ou entretien (sans dépasser les limites de poids), l'utilisation déraisonnable ou abusive, les dommages causés par le gel, la rouille, les frais de transport et d'emballage pour des pièces achetées ou retournées. Une preuve d'achat (reçu de caisse daté) est requise pour les réclamations sous garantie.

COMMENT FAIRE POUR OBTENIR DU SERVICE

Pour de plus amples renseignements, veuillez communiquer avec notre département du service à la clientèle

SOINS

- Les soins et le nettoyage doivent être faits avec un chiffon doux et de l'eau.
- Ne pas utiliser de produits abrasifs et de laine d'acier.
- Ne pas exposer les meubles aux intempéries ou à la chaleur excessive.

QUÉ ESTÁ CUBIERTO

Este producto está cubierto por la garantía limitada de 6 meses de nuestro fabricante. Para asegurar su total satisfacción, ésta garantiza al comprador original que el artículo proporcionado se encuentra libre de defectos materiales y de fabricación, a partir de la fecha de compra, y que permanecerá en tal estado, sometido a un uso normal y cuidados adecuados, durante los seis meses posteriores a la fecha de la compra.

Las partes faltantes o que presenten defectos al inicio de ese período de tiempo serán enviadas sin cargo, durante un lapso de 30 días a partir de la fecha de compra, mediante la presentación de un comprobante de compra válido, siempre que las partes estén disponibles en nuestro almacén y el artículo adquirido sea parte de nuestro inventario actual.

QUÉ NO ESTÁ CUBIERTO

El cliente asumirá los costos de flete y empaque hacia y desde el centro de servicio de cliente. Los cargos de material y mano de obra para extraer o reemplazar partes en el marco de la garantía no están cubiertos.

Esta garantía no cubre: muebles utilizados con fines comerciales, fallas causadas por montaje de instalación inadecuados o uso indebido (se recomienda no exceder los límites de peso), uso no razonable o abusivo, daños por congelación, oxidación, partes compradas, flete de devolución y cargos de empaque. Se exigirá el comprobante de compra (la factura de registro con fecha) para hacer valer la garantía.

CÓMO OBTENER SERVICIO

Si desea más información, póngase en contacto con nuestro departamento de servicio al cliente

CUIDADOS

- La conservación y limpieza debe ser hecha con un trapo levemente humedecido en agua.
- No use productos abrasivos y esponja de acero.
- No exponer el mueble a intemperies ni al calor excesivo.