

Assembly Instructions



Video for
Pneumatic
telescopic rod



Assembly
video



For any missing hardware, damaged parts and other problems.
WELCOME to email us at: service@behousewell.com

Or call at 1-888-733-8169 Toll free Toll free
Between 9AM and 5PM Eastern time, Monday through Friday

***Don't fully tighten all the bolts till the very end!**

PRE-ASSEMBLY PREPRATION :

- A cordless drill is recommended for ease of assembly.
- Clear out the space for assembly and lay out all of the parts based on the Parts List, extra room will allow you to easily determine if all the pieces are present.
- Keep small parts and pieces away from children until fully assembled.



A1

**Left
Arm**

1pc



C

Seat

1pc

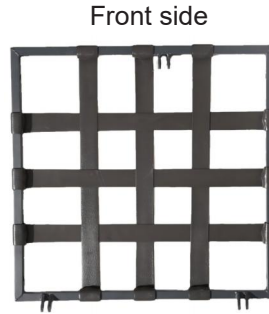

F

Base

1pc



A2

**Right
Arm**

1pc



D

**Front
Panel**

1pc



R

**Seat
Cushion**

1pc



B

Back

1pc



E

**Support
Frame**

1pc

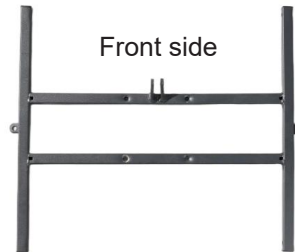







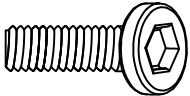

S

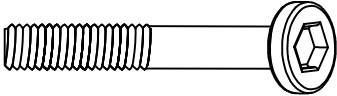
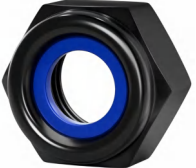
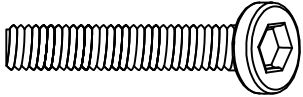
**Back
Cushion**

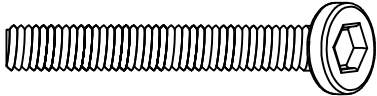
1pc



No.	Part/Size	QTY	Image	No.	Part/Size	QTY	Image
G	Bolt (M6*15mm)	2	**Actural Scale 	L	Nut	4	 M6
H	Bolt (M6*35mm)	14	**Actural Scale 	M	Nut	6	 M8
I	Bolt (M8*30mm)	4	**Actural Scale 	N	Allen Wrench	1	 4mm
J	Bolt (M8*40mm)	2	**Actural Scale 	O	Allen Wrench	1	 5mm
K	Washer	20		P Q	Wrench	1	P  M6 Q  M8

Step 1 Attach right arm A2 to seat C with 2 bolts H and 2 washers K, using Allen wrench N. **Note : Don't fully tighten the bolts !**

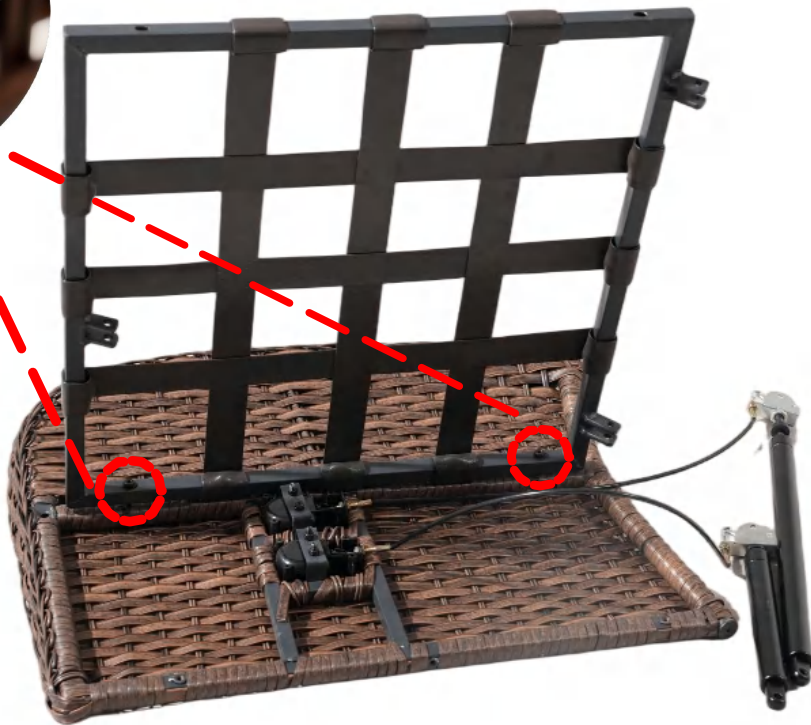
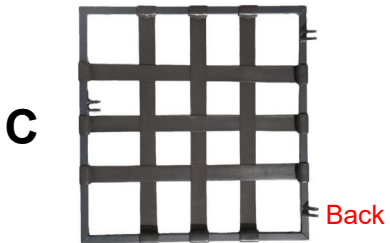
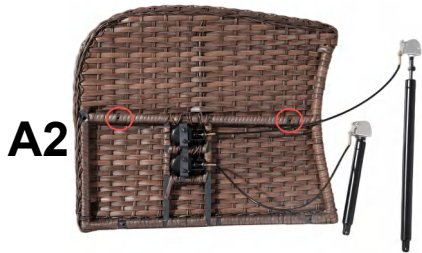
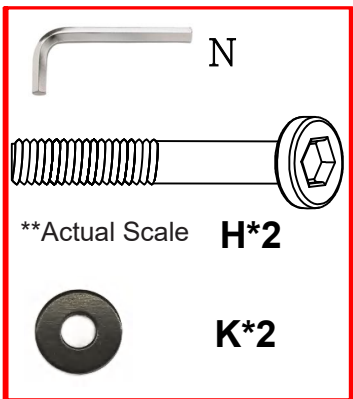

Step 2 Attach right arm A2 to part E with 2 bolts H and 2 washers K, using Allen wrench N. *Note : Don't fully tighten the bolts !*

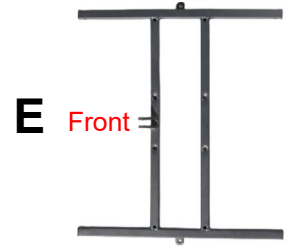
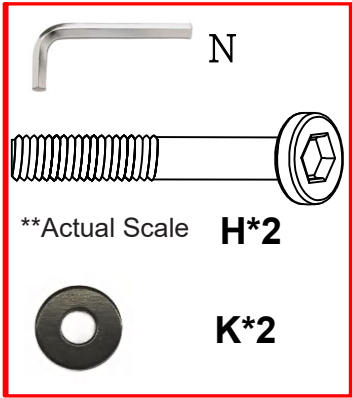

Step 3 :Attach the front panel D to right arm A2 with 1pc bolt H and 1pc washer K , using Allen wrench N. **Note : Don't fully tighten the bolts !**

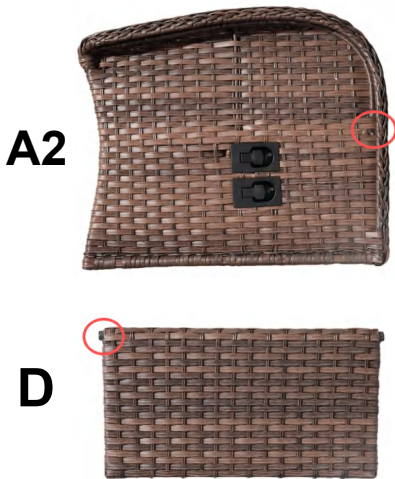
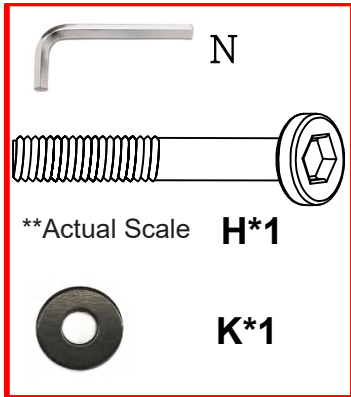

Step 4 :Attach the front panel D to left arm A1 with 1pc bolt H and 1pc washer K , using Allen wrench N. **Note : Don't fully tighten the bolts !**

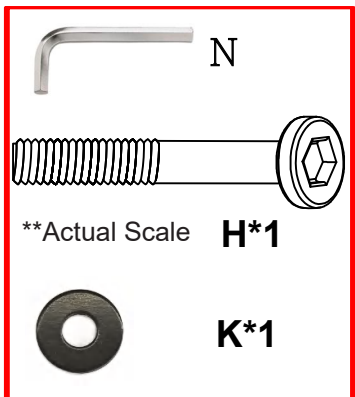

Step 5 Attach left arm A1 to seat C with 2 bolts H and 2 washers K, using Allen wrench N. *Note : Don't fully tighten the bolts !*

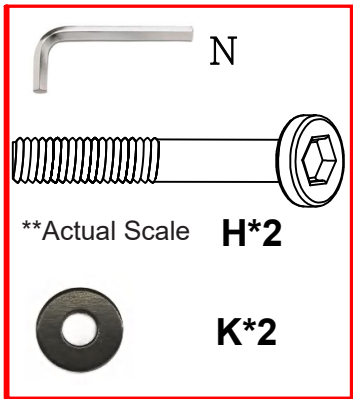

A1



C



Step 6 Attach left arm A1 to part E with 2 bolts H and 2 washers K, using Allen wrench N. *Note : Don't fully tighten the bolts !*

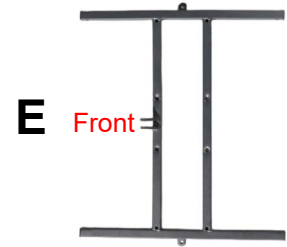
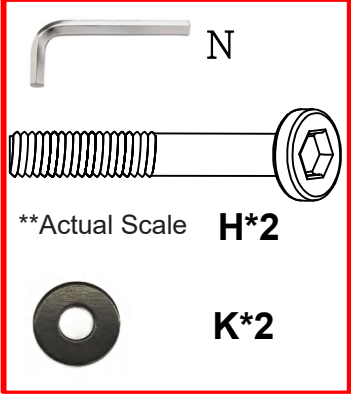

Step 7 Attach part E to arms A1 and A2 with 2pcs bolts G and 2pcs washers K , using Allen wrench N . *Note : Don't fully tighten the bolts !*

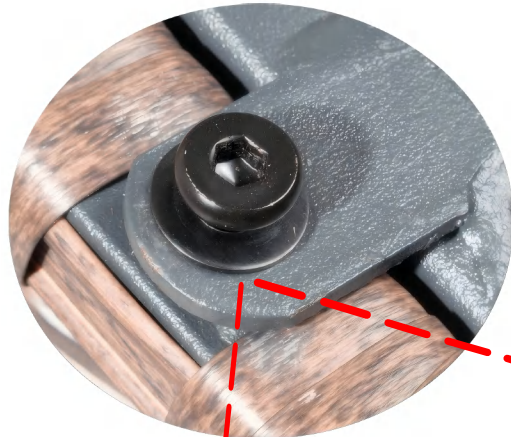
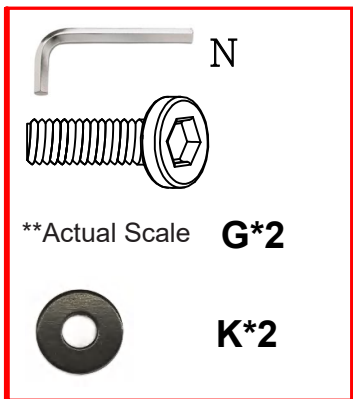

Step 8

Attach back B to seat C with 2pcs bolts I and 2pcs nut M ,using Allen wrench O and wrench Q . *Note : Don't fully tighten the bolts !*

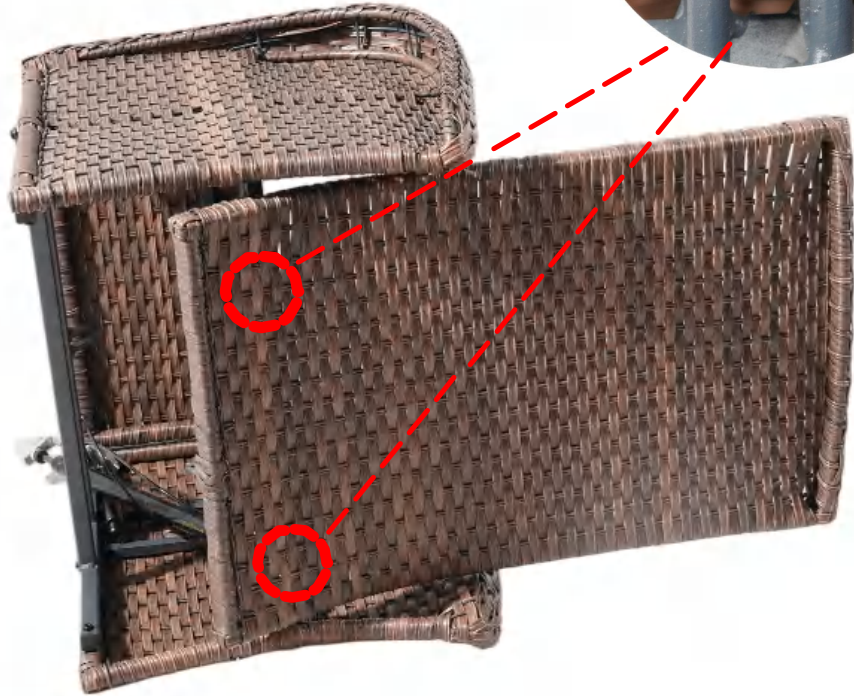
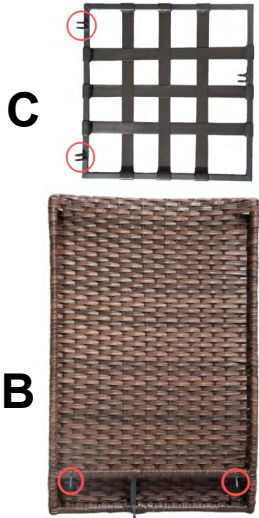
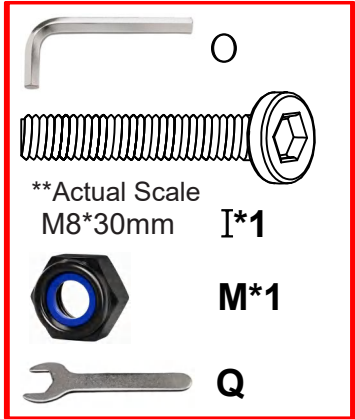

Step 9 Attach E to short pneumatic telescopic rod of right arm A2 with 1pc bolt J and and 1pc nut M ,Using Allen wrench O and wrench Q .

Note : Don't fully tighten the bolts !

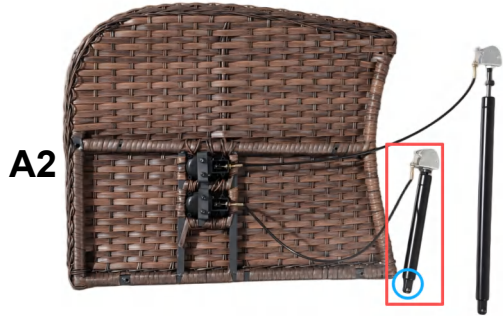
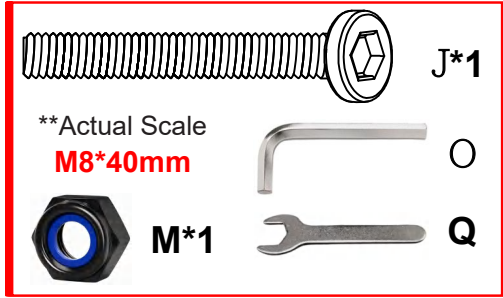

Step 10

Attach front panel D to short pneumatic telescopic rod of right arm A2 with 1pc bolt I and 1pc nut M ,Using Allen wrench O and wrench Q .

Note : Don't fully tighten the bolts ! The direction of the hook is as shown in the figure.

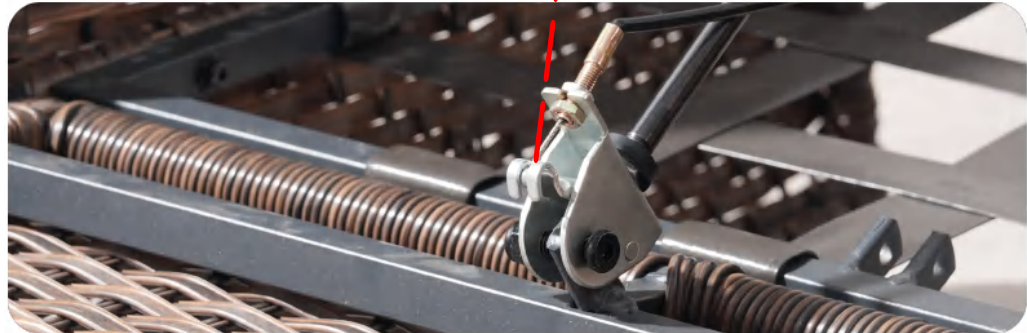
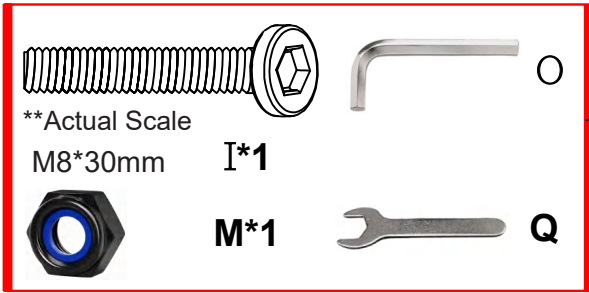

Step 11 Attach seat C to long pneumatic telescopic rod of right arm A2 with 1pc bolt J and 1pc nut M , Using Allen wrench O and wrench Q .

Note : Don't fully tighten the bolts !

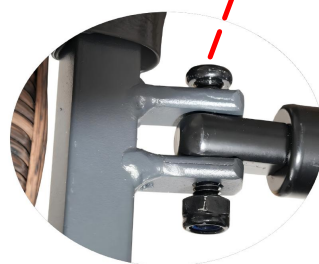
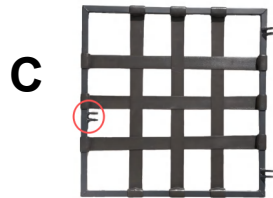
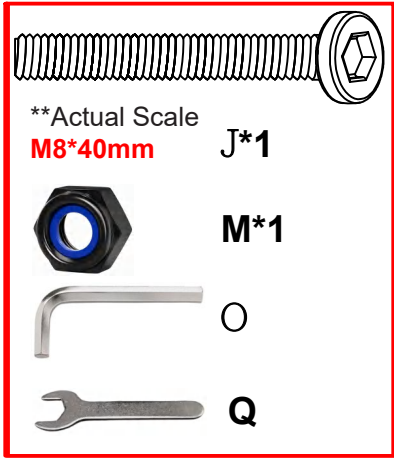

Step 12 Attach back B to long pneumatic telescopic rod of right arm A2 with 1pc bolt I and 1pc nut M ,Using Allen wrench O and wrench Q .

Note : Don't fully tighten the bolts !

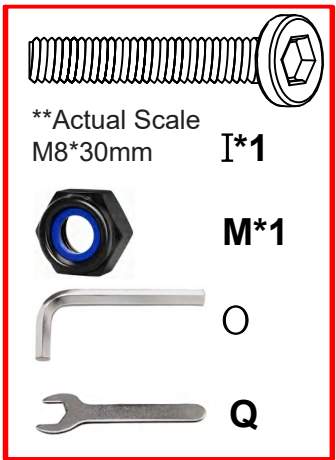

A2

B



Step 13 Attach base F to E with 4pcs bolts H, 8pcs washers K, and 4pcs nut L, using Allen wrench N and wrench P. **Note : Fully tighten all the bolts !**

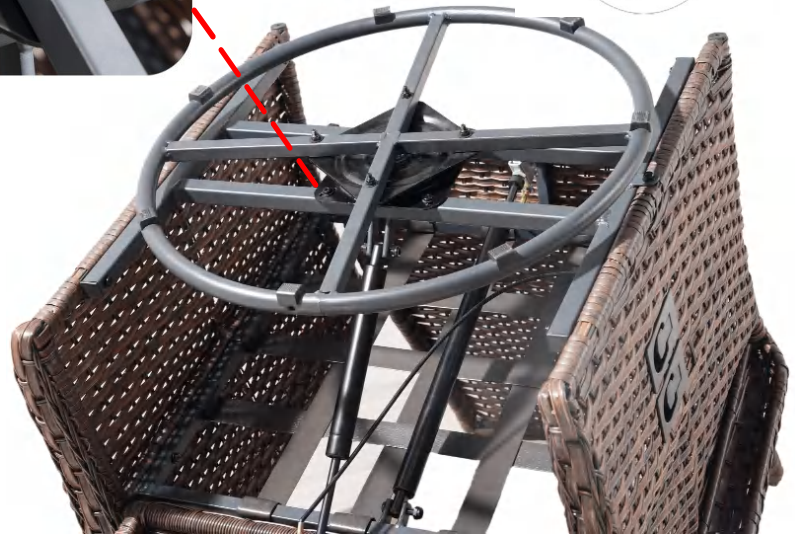
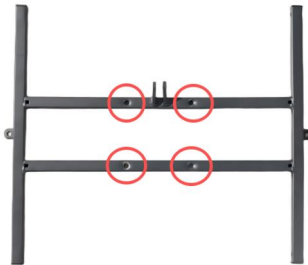
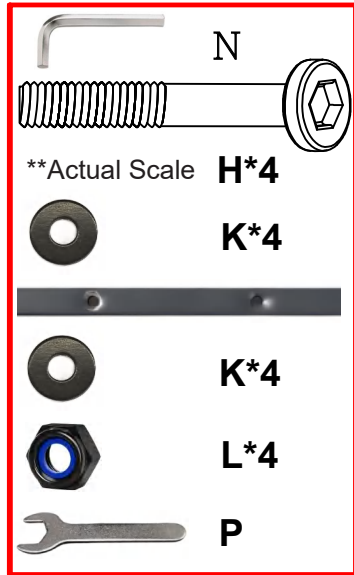

Step 13 Put Seat Cushion R and Back Cushion S.



S

R





Insufficient supporting from the back or front panel. Please rotate the pneumatic telescopic rod to the correct position.

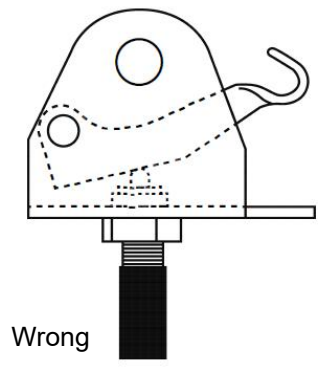

The opening and closing angle is too large. Please rotate the pneumatic telescopic rod to the correct position.



Unable to be fully closed

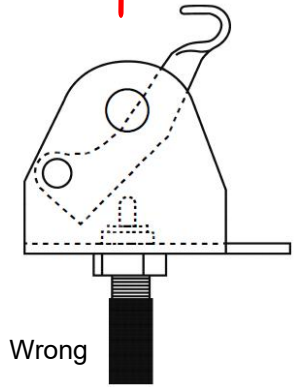

1. Loosen the large nut
2. Rotate the rod to the correct position.
3. Tighten the large nut .

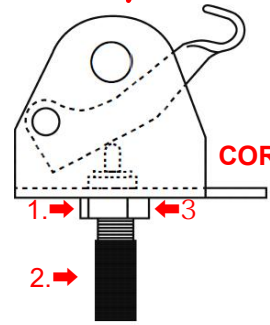

SPECIAL WARNING :

THIS CHAIR IS NOT A TOY. DON'T OVER-SWING THE CHAIR .OVER-SWING THE CHAIR MAYBE MAKE THE CAHIR TIP OVER AND RESULT IN INJURY. DO NOT STAND ON THE CHAIR . ANY IMPROPER USE OF THIS PRODUCT MAY RESULT IN INJURY .



Q & A:

Q: Frame drilling holes not align?

A: If discrepancy less than 1/8 in., please loosen other relative bolts first, then adjust parts position and re-tight all bolts.

if discrepancy more than 1/4 in., it should be parts deformation during violent transportation, please contact us for parts replacement.

Q: Why cushion shrink packing and how to help it rebound faster?

A: We shrink packing cushion is to improve product value to cost, because it can save transport cost a lot. We filled it with more and high-quality filling than normal cushion to make sure it can be fully rebound. Following up this video(<https://youtu.be/IZAIHQ9Ial>)method to speed up rebounding.

Q: Coffee table legs un-even?

A: Loosen bolts, then press table downwards, then tighten bolts again. If it can not solve problem, please contact us for parts replacement.

Q: Wicker colors different on parts?

A: We make wicker stripes to fit for nature environment, colors may various circularly. So when those wicker stripes hand-woven on product randomly, it may looks different on parts.

Q: Why some swivel plate not work well?

A: Swivel plate may need a running-in period like 10~20 cycles. If it still not swivel well, please contact us for swivel plate replacement.

Q: Bolts are not long enough for assembly sometimes?

A: Sometimes gaps maybe larger than the bolts to reach out when assembly, please contact us for longer bolts. After all, those parts are woven by hand-made. But after it assembled and all bolts tightened, the gaps will be disappeared, because wicker parts are flexible surface.

Q: Parts received damaged?

A: Although we had already did our best to pack products well, there are also unpredictable transport damages accident happened from time to time. When it happens, please contact our after-sales email, state the order number/which shopping platform it comes from/one of the parcel tracking number, and provide the relevant pictures of the problem, we will immediately provide you with a suitable replacement parcel.

Q:Received item but missing hardware or parts

A:Please contact our after-sales email, state the order number/which shopping platform it comes from/one of the parcel tracking number, and provide the relevant pictures of the problem, we will immediately provide you with a suitable replacement parcel.

How to take care of the product

1. Maintain your outdoor furniture by using furniture covers or storing out of the elements when not in use.

2. Wicker: Wipe surface dust with warm water

3. Frame: Clean frames with a mild soap and warm water, rinse with clean water and dry thoroughly. Do not use abrasive materials or strong detergents

4. Fabric: Clean with mild soap and water. Do not put cushions in dryer.

5. In cold climates, drain any water accumulated inside the frames before storing.