

**DRESSER IPANEMA 4GV - 0,90M**  
**CÓMODA IPAMENA 4GV - 0,90M**  
**CÔMODA IPANEMA 4GV - 0,90M**





- **Before starting assembly, make sure you have received all the components and product parts.**
- Antes de comenzar el montaje, asegúrese de haber recibido todos los componentes y piezas del producto.
- Antes de iniciar a montagem, verifique se você recebeu todos os componentes e peças do produto.
- **For assembly, we suggest hiring a professional.**
- Para el montaje, sugerimos contratar a un profesional.
- Para montagem, sugerimos contratação de um profissional.

## ASSEMBLY INSTRUCTIONS

### INSTRUCCIONES DE MONTAJE

### INSTRUÇÕES DE MONTAGEM



Necessary people.  
Gente necesaria.  
Pessoas necessárias.



Difficult level - high.  
Nível de dificultad - alto.  
Grau de dificuldade - alto.



Avoid bumps and sharp objects.  
Evitar golpes y objetos afilados.  
Evitar batidas e objetos cortantes.



Cloth slightly dampened with water,  
followed by a dry cloth.  
Paño ligeramente humedecido con  
agua, seguido de un paño seco.  
Pano levemente umedecido com  
água, seguido de pano seco.

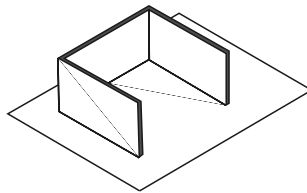

The module must be mounted on a soft surface.  
**Tip:** Use the box.  
El módulo debe montarse sobre una superficie  
blanda. **Consejo:** Usa la caja.  
Deve-se fazer a montagem do módulo em cima  
de uma superfície macia. **Dica:** Usar a caixa.



Don't use chemicals or abrasives for cleaning.  
No utilice productos químicos o abrasivos  
para la limpieza.  
Não utilizar químicos ou abrasivos na  
limpeza.

## Required Tools

### herramientas requeridas / Ferramentas

### Necessárias

(not provided / no provisto / não fornecidas)



Measuring tape  
Cinta métrica  
Fita métrica



Philips Screwdriver  
Destornillador Philips  
Chave Philips



Hammer  
Martillo  
Martelo



Power Drill  
Taladro  
Furadeira



ø 6mm e 10mm  
ø 6mm and 10mm  
ø 6mm y 10mm

# Module Components

## Componentes del Módulo

## Componentes do Módulo

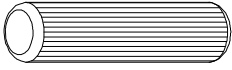

A - Wood Dowel 8x30 (8x)  
 A - Espiga 8x30 (8x)  
 A - Cavilha 8x30 (8x)

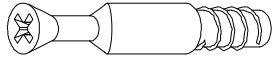

B - Twister Dowel (4x)  
 B - Minifix (4x)  
 B - Minifix (4x)

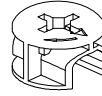

C - Cam Lock (4x)  
 C - Tambor (4x)  
 C - Tambor (4x)

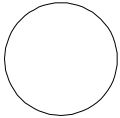

D - Self Adhesive Cap Cover (4x)  
 D - Tapa Aguejo Autoadhesivos (4x)  
 D - Tapa Furo Adesivo (4x)



F11 - Euro Screw  $\text{\O}6 \times 10$  (16x)  
 F11 - Tornillo Euro  $\text{\O}6 \times 10$  (16x)  
 F11 - Parafuso Euro  $\text{\O}6 \times 10$  (16x)

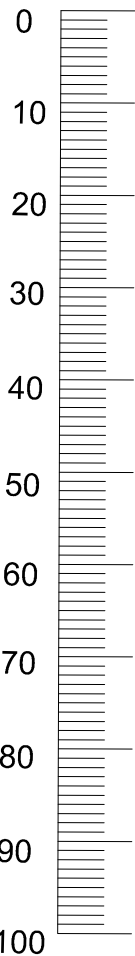

measures in mm / medidas em mm

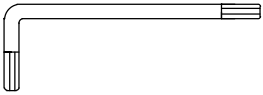

R1 - Allen Key (1x)  
 R1 - Llave Allen (1x)  
 R1 - Chave Allen (1x)



F4 - Platter Screw  $\text{\O}4 \times 25$  (8x)  
 F4 - Tornillo Plato  $\text{\O}4 \times 25$  (8x)  
 F4 - Parafuso Travessa  $\text{\O}4 \times 25$  (8x)



F9 - Euro Screw  $\text{\O}5 \times 35$  (4x)  
 F9 - Tornillo Euro  $\text{\O}5 \times 35$  (4x)  
 F9 - Parafuso Euro  $\text{\O}5 \times 35$  (4x)



F6 - Foot Screw  $\text{\O}4 \times 40$  (8x)  
 F6 - Tornillo Pie  $\text{\O}4 \times 40$  (8x)  
 F6 - Parafuso Pé  $\text{\O}4 \times 40$  (8x)

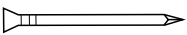

E - Nail 10x10 (22x)  
 E - Clavo 10x10 (22x)  
 E - Prego 10x10 (22x)

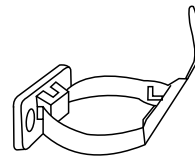

Z - Anti tipping (1x)  
 Z - Kit Antivuelco (1x)  
 Z - Kit Anti Tombamento (1x)

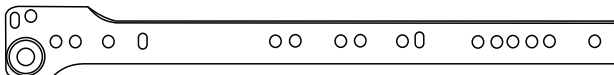

I2 - Module Slide (8x)  
 I2 - Corrediza Módulo (8x)  
 I2 - Corrediça Módulo (8x)

# Drawer Components

## Componentes del Cajón

## Componentes da Gaveta

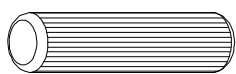

A - Cavilha 8x30 (16x)  
 A - Wood Dowel 8x30 (16x)  
 A - Espiga 8x30 (16x)

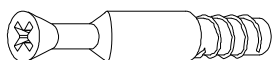

B - Twister Dowel (8x)  
 B - Minifix (8x)  
 B - Minifix (8x)

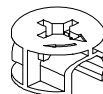

C - Cam Lock (8x)  
 C - Tambor (8x)  
 C - Tambor (8x)

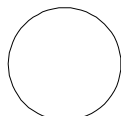

D - Self Adhesive Cap Cover (8x)  
 D - Tapa Aguejo Autoadhesivos (8x)  
 D - Tapa Furo Adesivo (8x)



F14 - Screw 4x16 (16x)  
 F14 - Tornillo 4x16 (16x)  
 F14 - Parafuso 4x16 (16x)



F9 - Euro Screw Ø5x35 (8x)  
 F9 - Tornillo Euro Ø5x35 (8x)  
 F9 - Parafuso Euro Ø5x35 (8x)

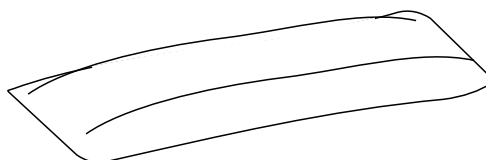

G - Glue (2x)  
 G - Pegamento (2x)  
 G - Cola (2x)

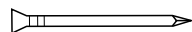

E - Nail 10x10 (36x)  
 E - Clavo 10x10 (36x)  
 E - Pregão 10x10 (36x)

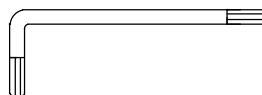

R1 - Allen Key (1x)  
 R1 - Llave Allen (1x)  
 R1 - Chave Allen (1x)



I 2 - Slide Drawer (8x)  
 I 2 - Corrediza Cajón (8x)  
 I 2 - Corrediça Gaveta (8x)

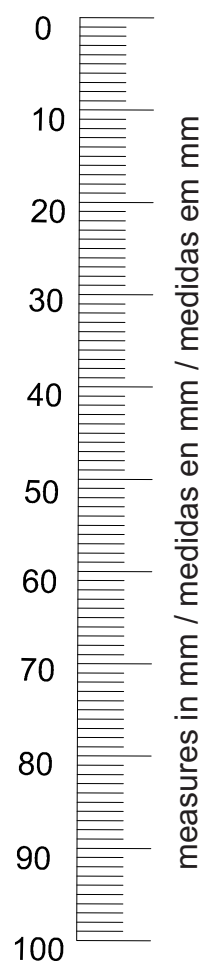

# Module Parts

## Partes del módulo

## Partes do módulo

**1** Top Base (1x)  
Base Superior (1x) / Base Superior (1x)

**2** Botton Base (1x)  
Base Inferior (1x) / Base Inferior (1x)

**3** Right Side (1x)  
Lado Derecho (1x) / Lateral Direita (1x)

**4** Left Side (1x)  
Lado Izquierdo (1x) / Lateral Esquerda (1x)

**5** Coast (2x)  
Costa (2x) / Costa (2x)

**100** Foot (4x)  
Pies (4x) / Pés (4x)

**101** Sleepers (2x)  
Traviesas (2x) / Travessas (2x)

**103** Bottom Connector (1x)  
Conector Inferior (1x) / Conector de Fundo (1x)

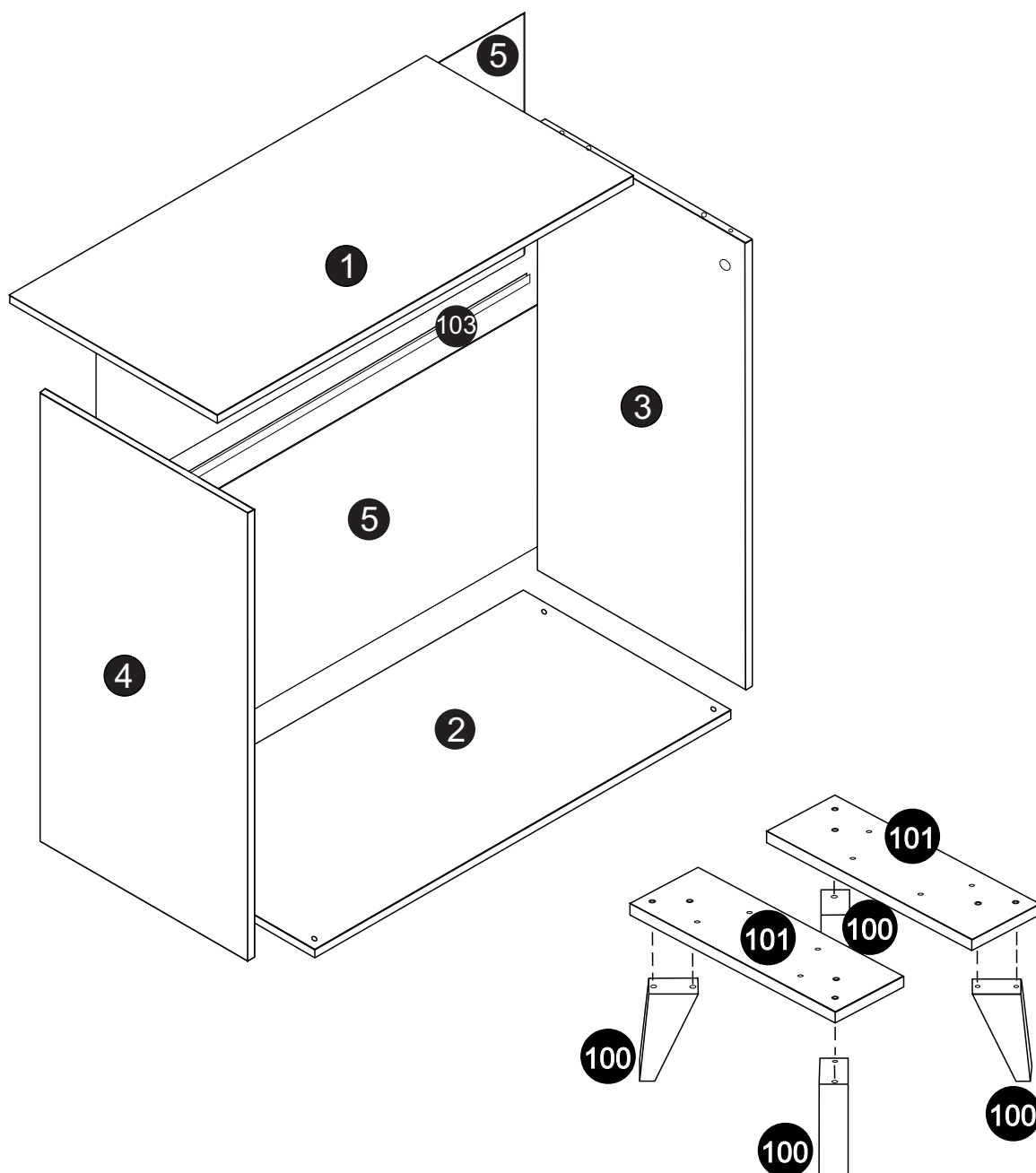

# Drawer Parts

## Partes del Cajón

## Partes da Gaveta

**50** Left Side Drawer (4x)  
Cajón Lado Izquierdo (4x) / Lateral Gaveta Esq. (4x)

**51** Right Side Drawer (4x)  
Cajón Lado Derecho (4x) / Lateral Gaveta Dir. (4x)

**52** Drawer Bottom (4x)  
Fondo Del Cajón (4x) / Fundo de Gaveta (4x)

**53** Drawer Back (4x)  
Base Del Cajón (4x) / Base de Gaveta (4x)

**54** Drawer Front (4x)  
Frente Del Cajón (4x) / Frente de Gaveta (4x)

04 Units

04 Unidades

04 Unidades

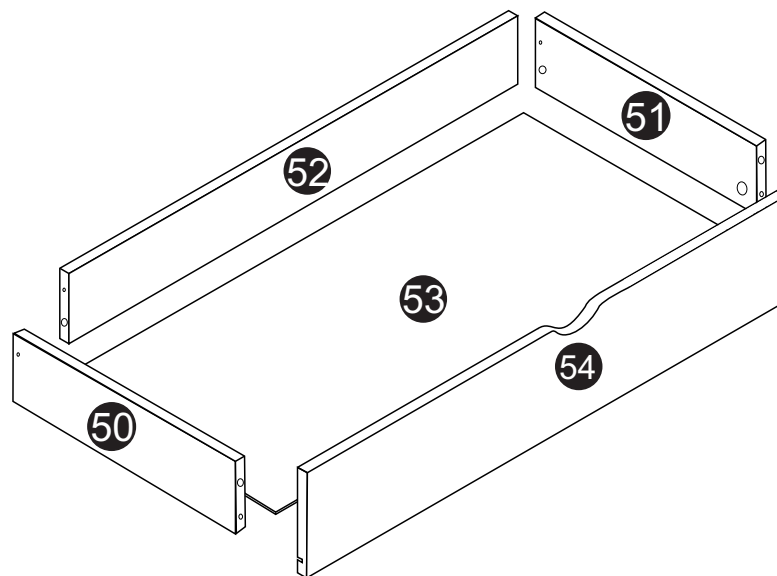

# Module pre-assembly

## Premontaje del módulo

## Pré montagem do módulo

01

Left  
Izquierda  
Esquerda

Right  
Derecha  
Direita

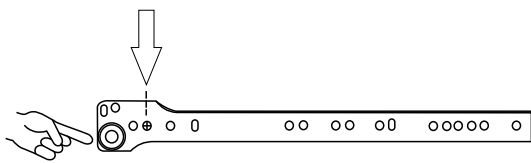

04

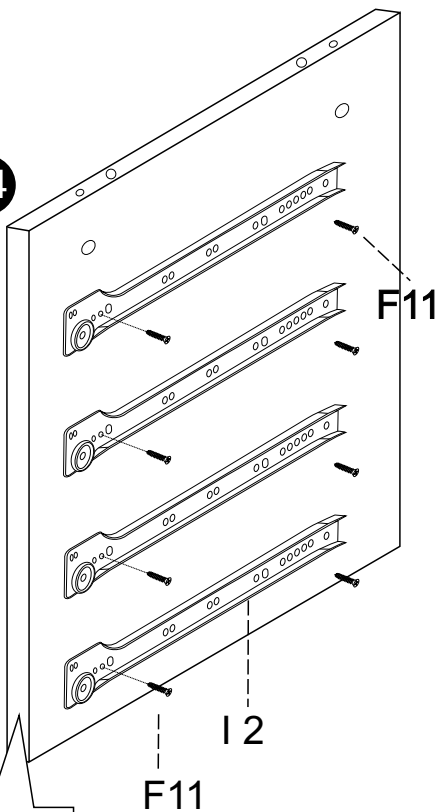

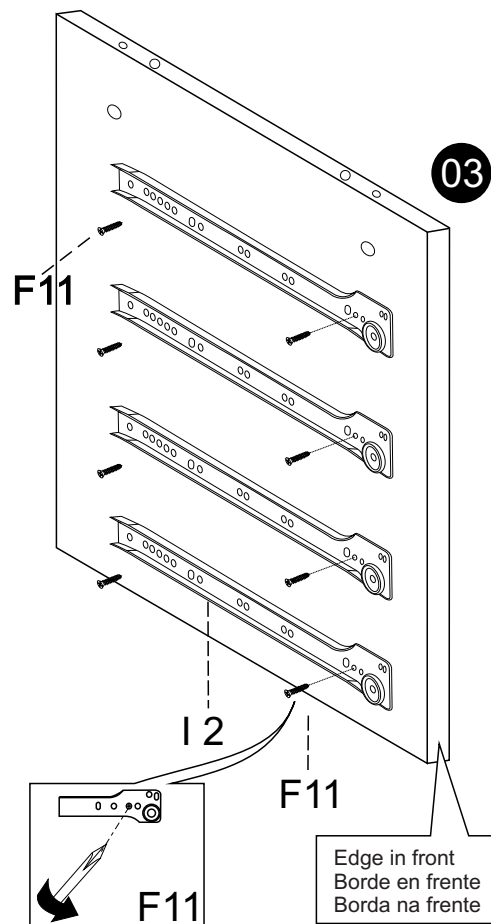

Edge in front  
Borde en frente  
Borda na frente

03



Edge in front  
Borde en frente  
Borda na frente

I2  08 PÇS  
F11  16 PÇS

# Module pre-assembly

## Premontaje del módulo

### Pré montagem do módulo

02

Left  
Izquierda  
Esquerda

Right  
Derecha  
Direita

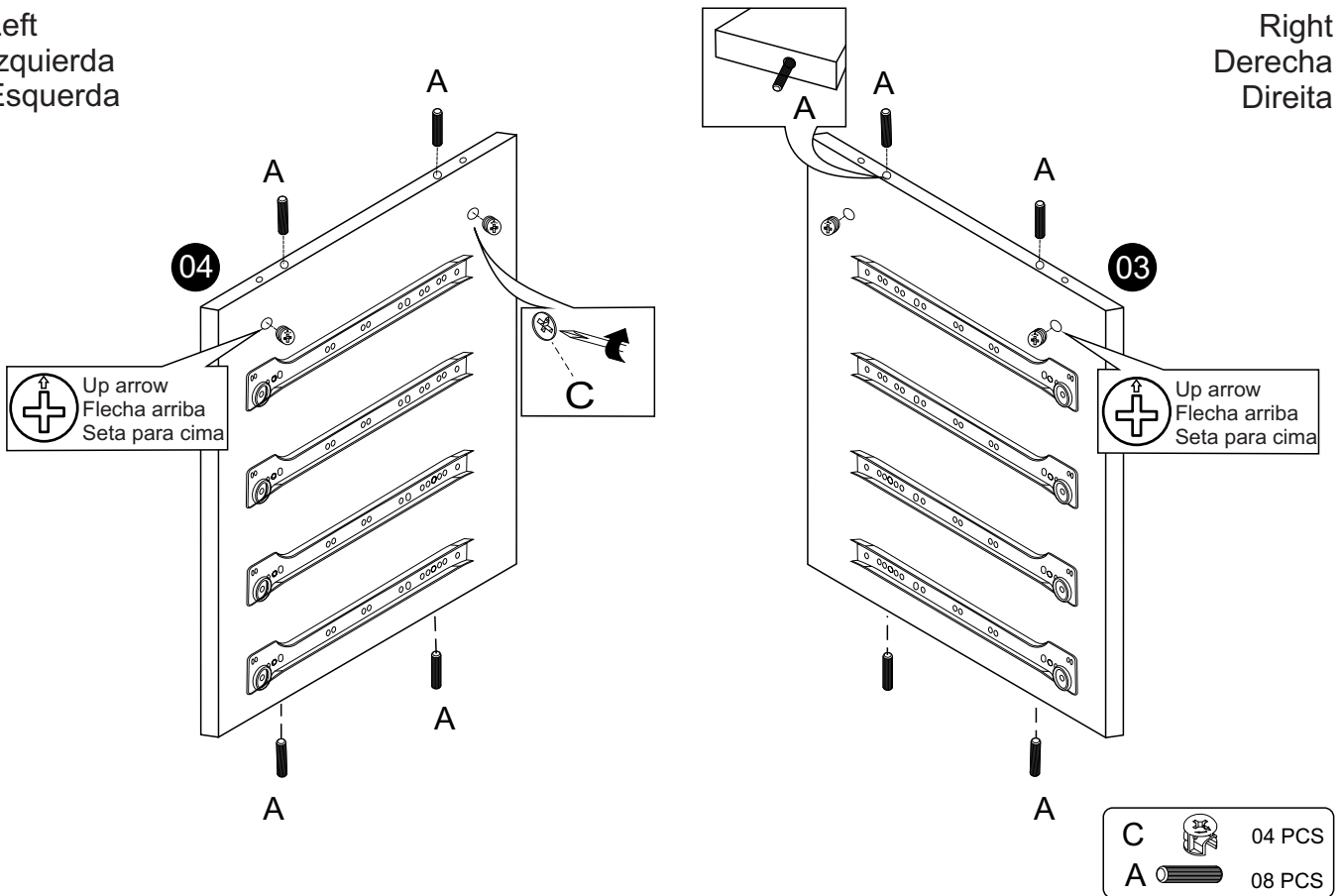

03

Top  
Base Superior  
Base Superior

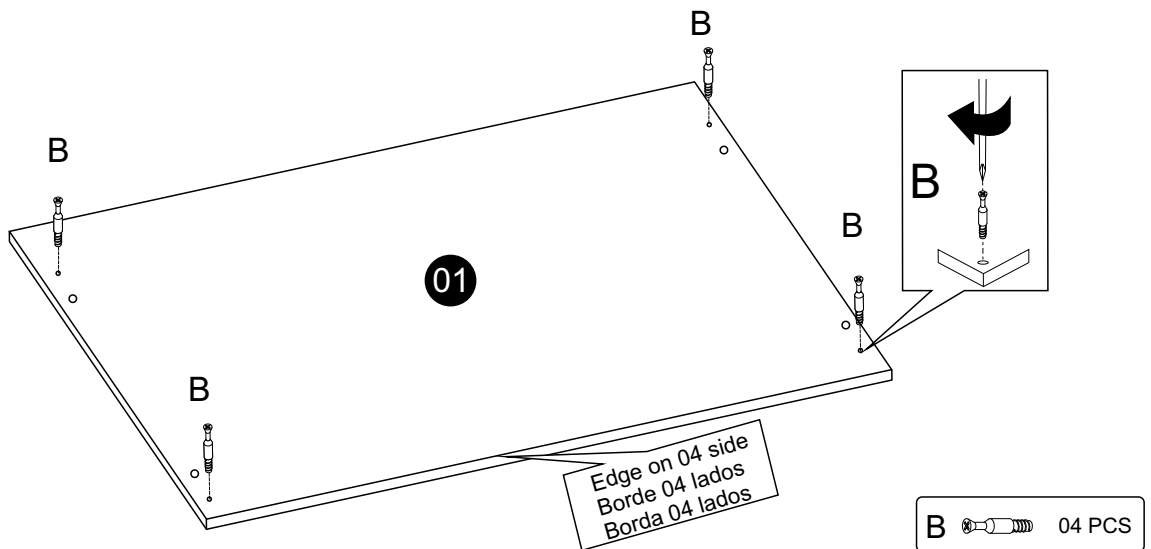

04

Bottom Base - Drawing conference  
Base Inferior - Conferencia de dibujo  
Base Inferior - Conferencia do desenho

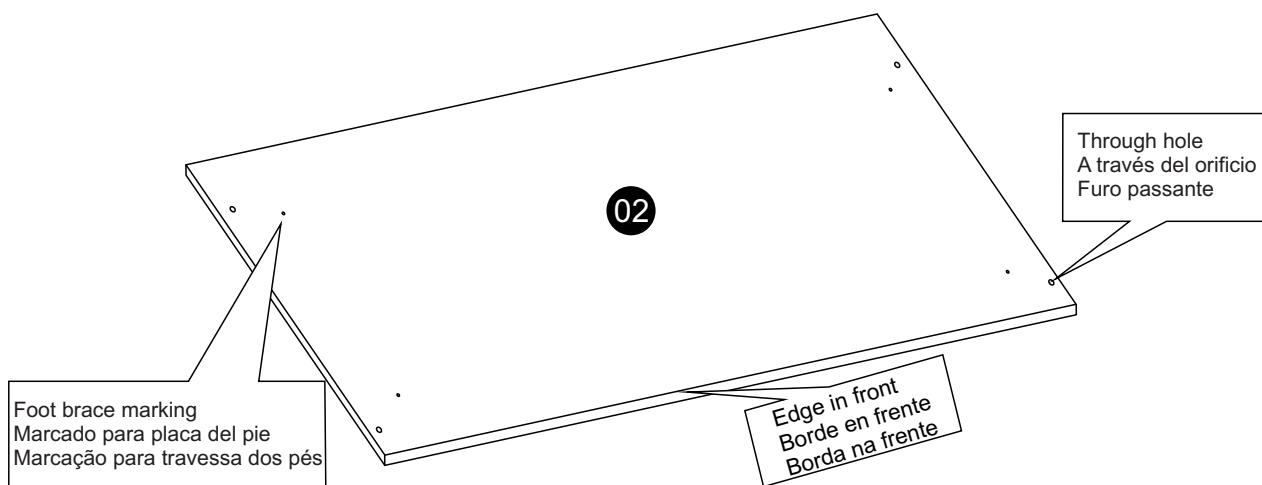

05

Back Panel  
Costa  
Costa

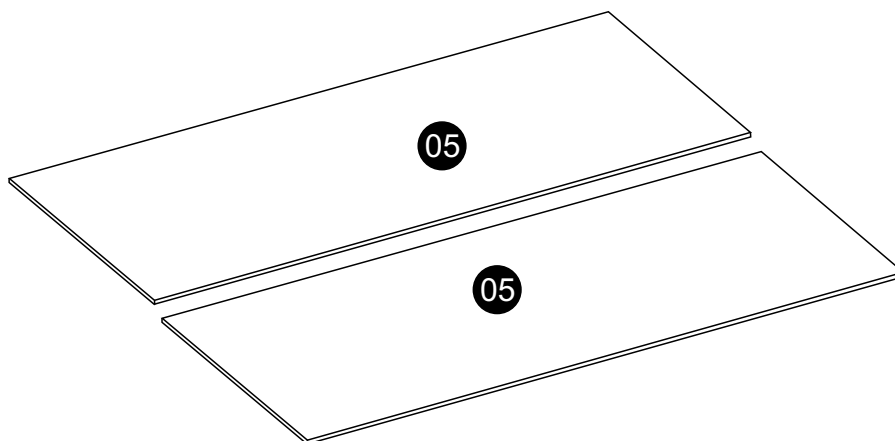

# Module assembly

Montaje del módulo

Montagem do módulo

01

Top + Left Side

Base Superior + Lado Izquierdo

Base Superior + Lat. Esquerda

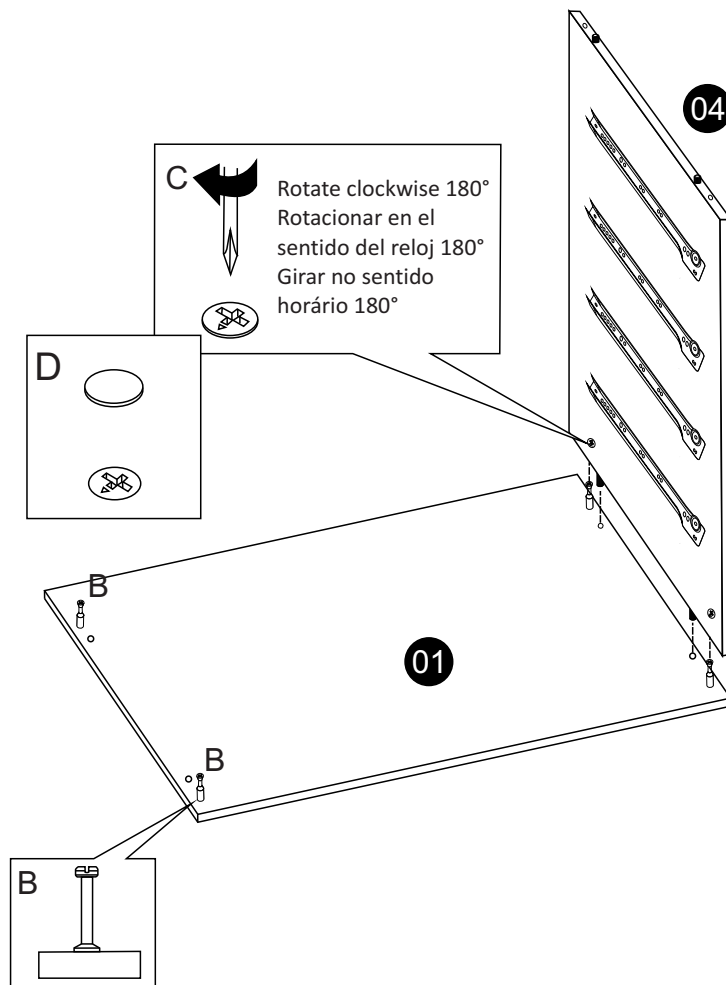

D  04 PCS

02

Top + Left Side + Right Side  
Base Superior + Lado Izquierdo + Lado Derecho  
Base Superior + Lat. Esquerda + Lat. Direita

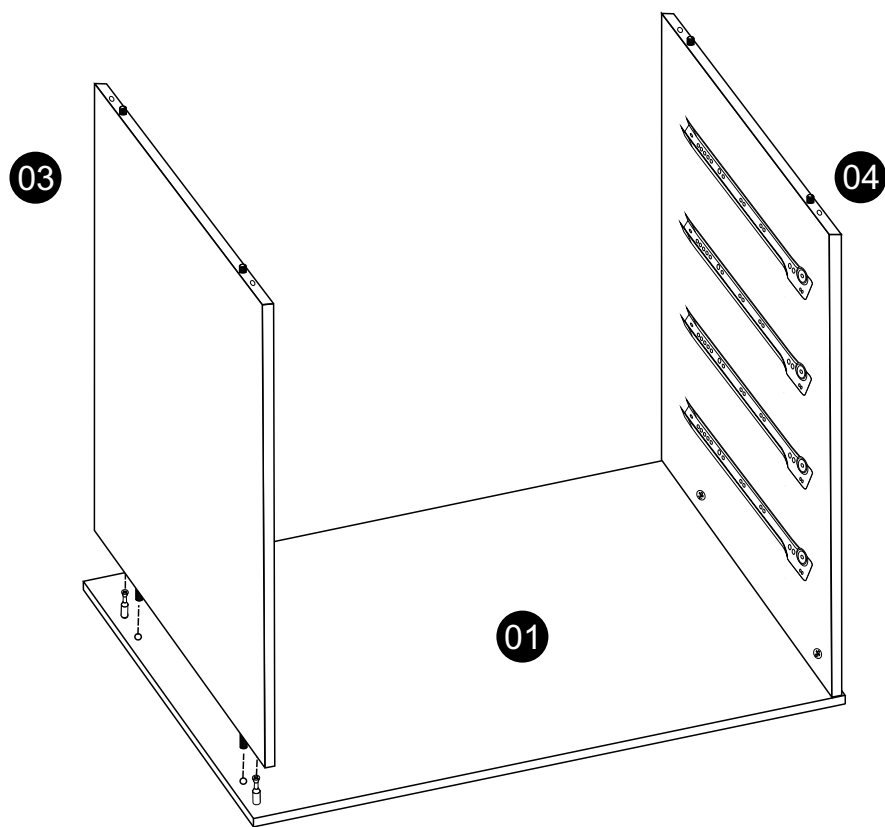

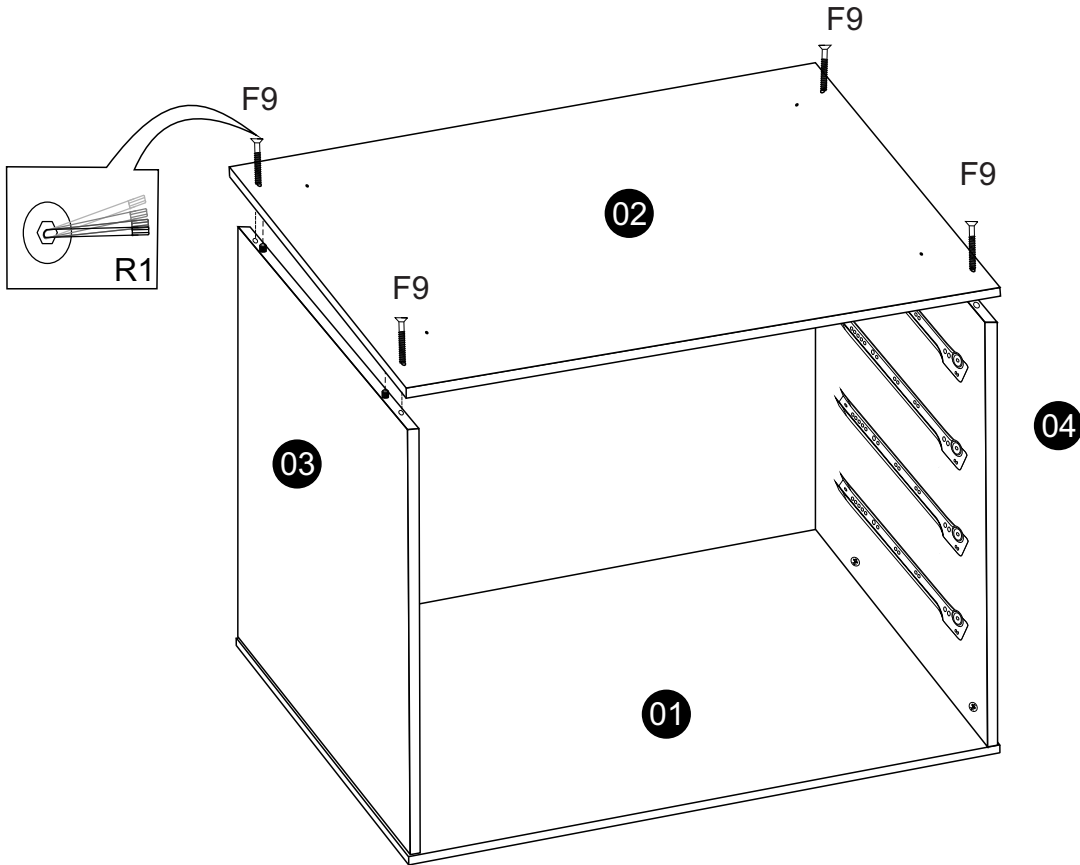

03

Top + Left Side + Right Side + Bottom Base  
Base Superior + Lado Derecho + Lado Izquierdo + Base Inferior  
Base Superior + Lat. Direita + Lat. Esquerda + Base Inferior

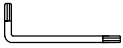

Use the Allen key to fix the lower base on the sides.  
Usa la llave Allen para fijar la base inferior a los lados.  
Utilizar a chave Allen para fixar a base inferior nas laterais.

R1 

F9  04 PCS  
R1  01 PCS

04

Bottom Connector  
Conector Inferior  
Conector de Fundo

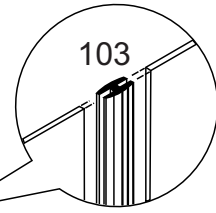
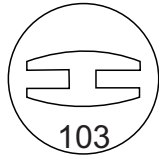

White inside  
Blanco por dentro  
Branco por dentro

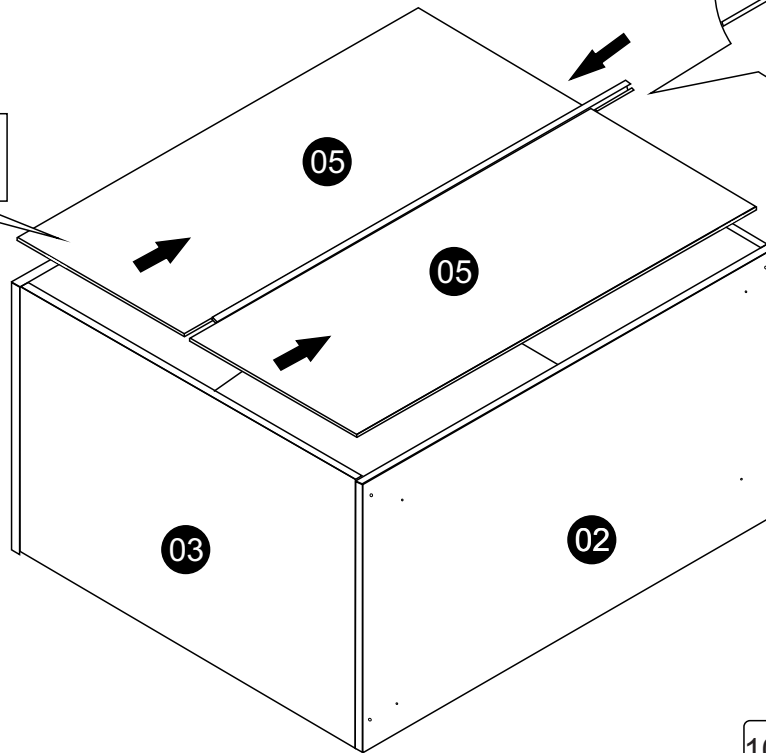

103  01 PCS

05

Check the coast square  
Revisa la plaza de la costa  
Conferir o esquadro da costa



Diagonal measurements must be equal.  
Medidas diagonales deben ser iguales.  
As medidas em diagonal devem ser iguais.

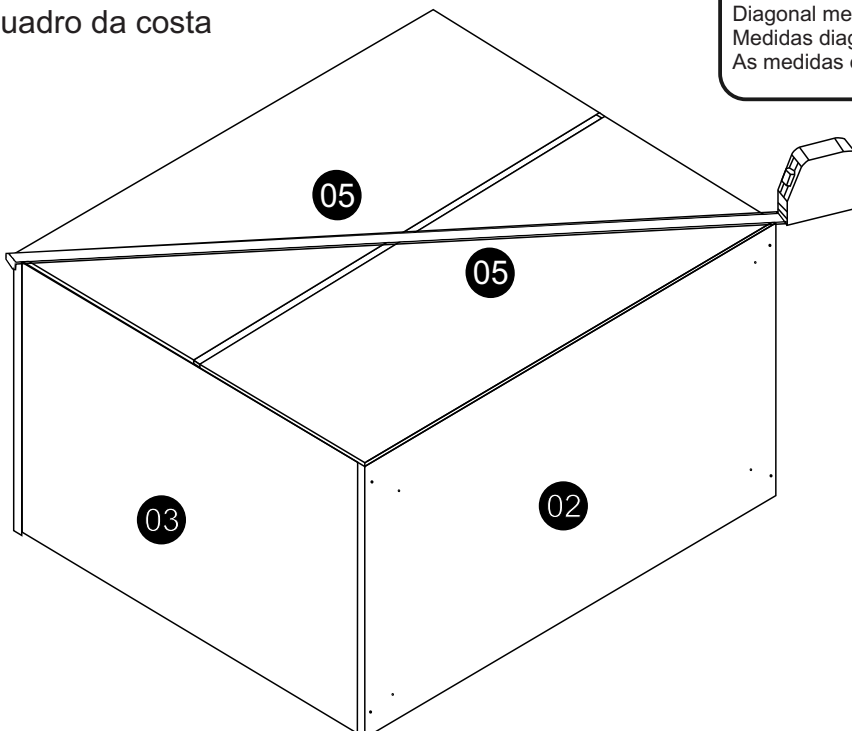

06

Mounting of coast  
Montaje del costa  
Montagem da costa

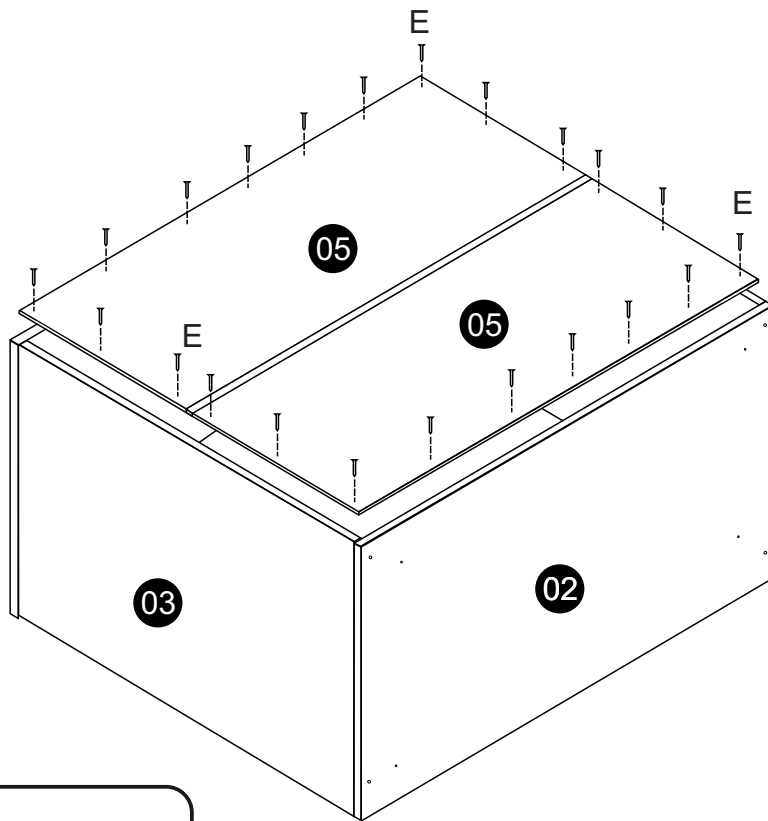

Note the amount of nails needed.  
Tenga en cuenta la cantidad de clavos necesarios.  
Observe a quantidade de pregos necessários.

E  22 PCS

07

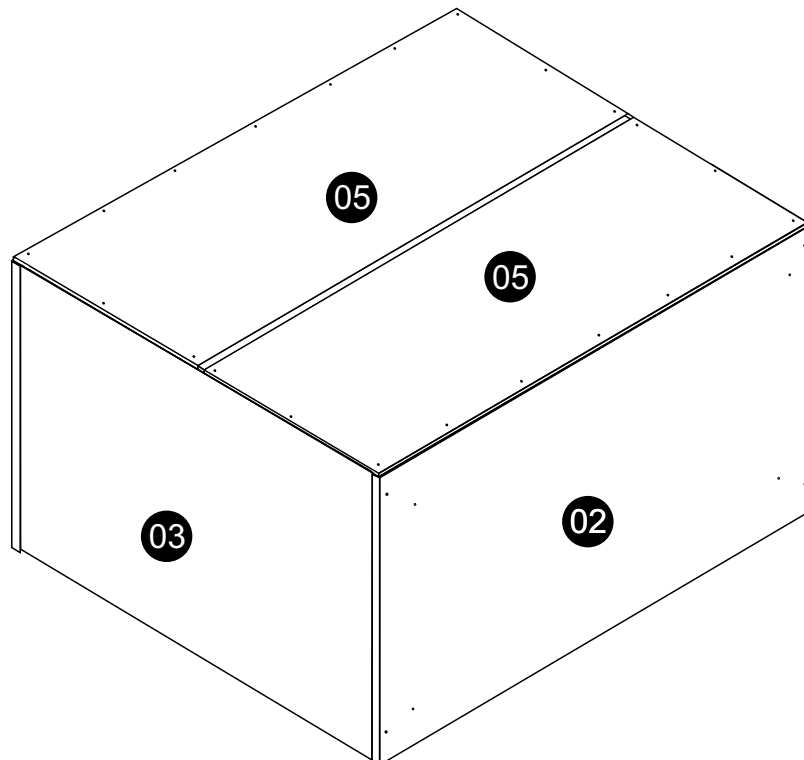



# Drawer pre-assembly

## Premontaje del cajón

### Pré montagem da gaveta

01

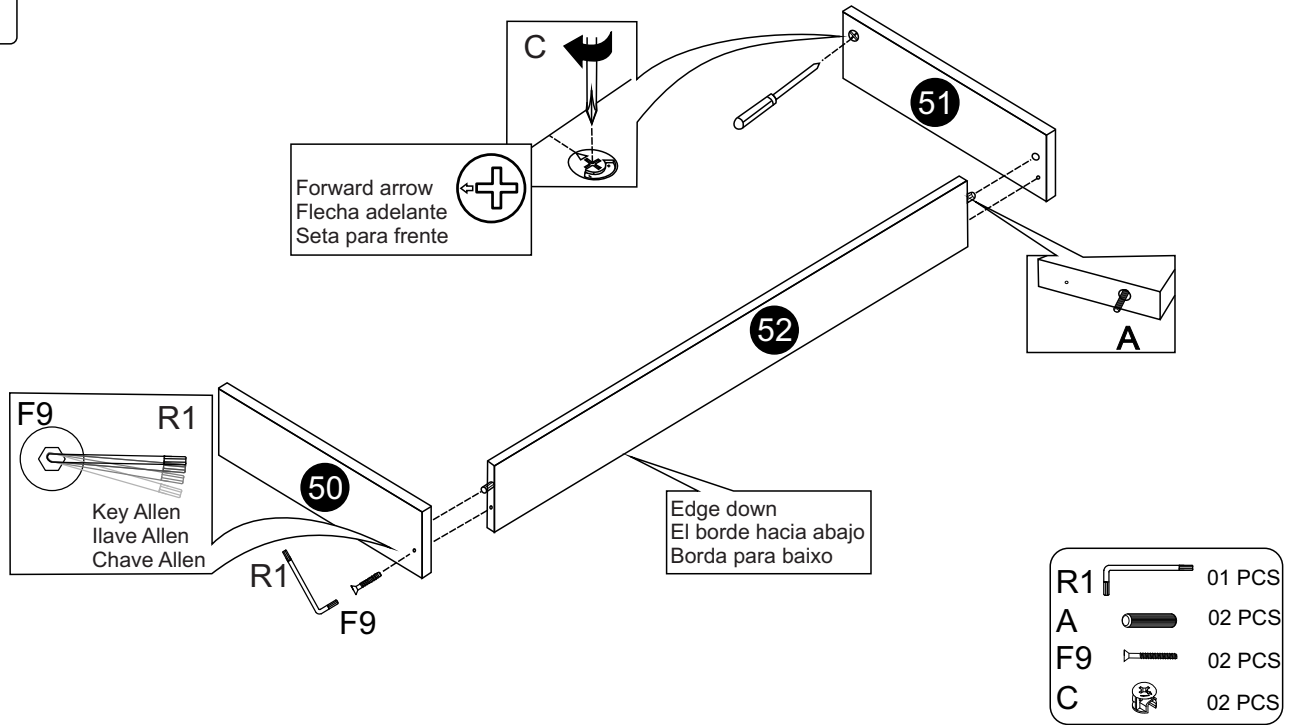

02

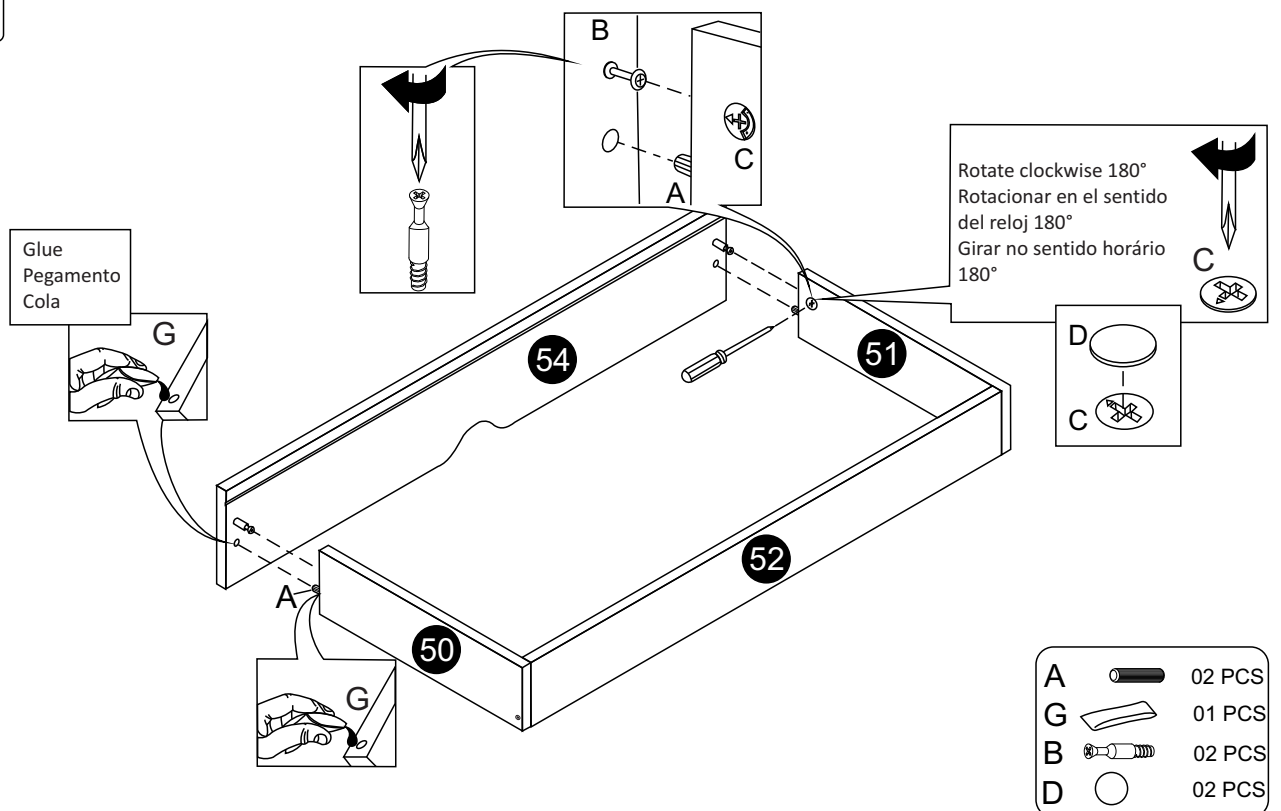

03

Glue application on the front of the drawer  
Aplicación de cola en el frente del cajón  
Aplicação de cola na frente da gaveta

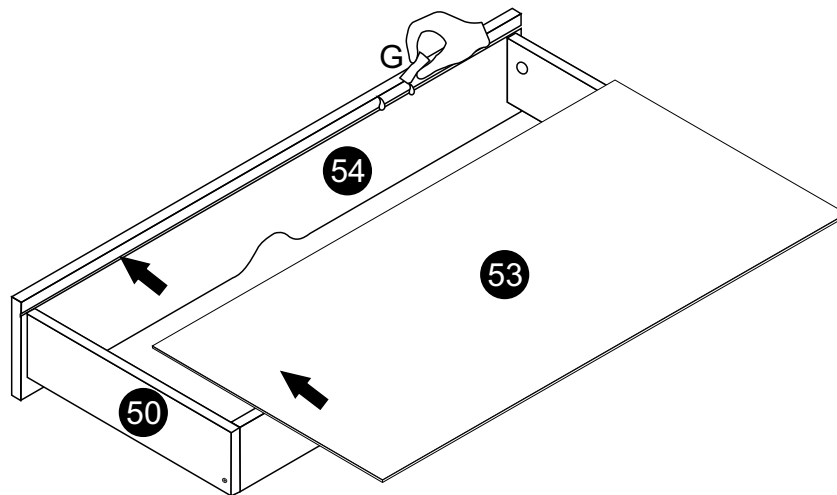

G  01 PCS

04

Check the drawer square  
Revisa la plaza del cajón  
Conferir o esquadro da gaveta

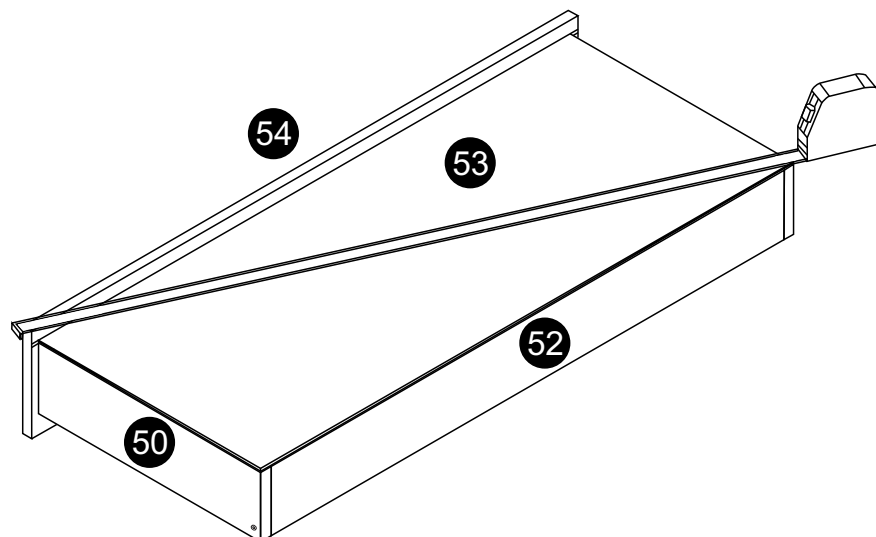

05



Note the amount of nails needed.  
Tenga en cuenta la cantidad de clavos necesarios.  
Observe a quantidade de pregos necessários.

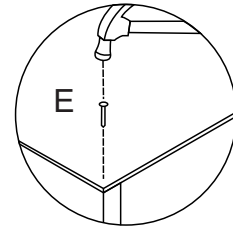
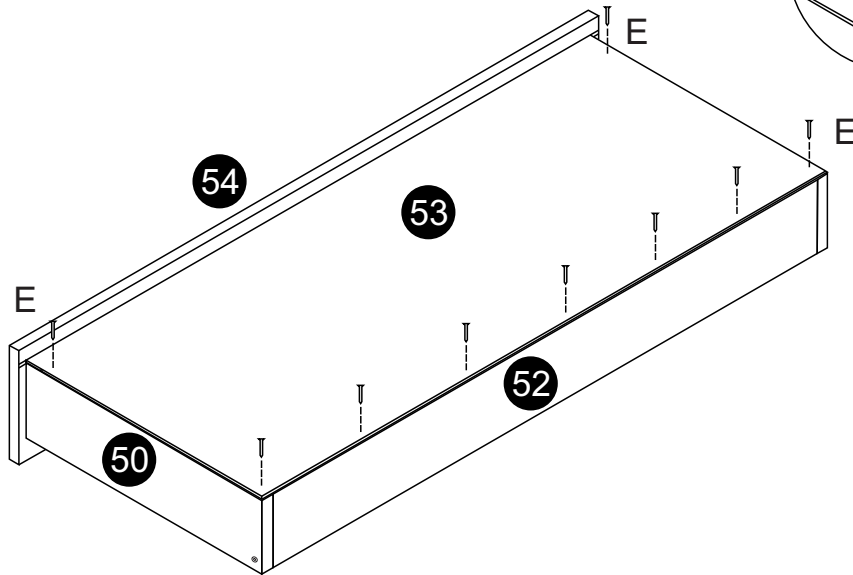

E  09 PCS

06

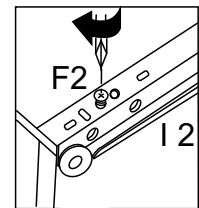
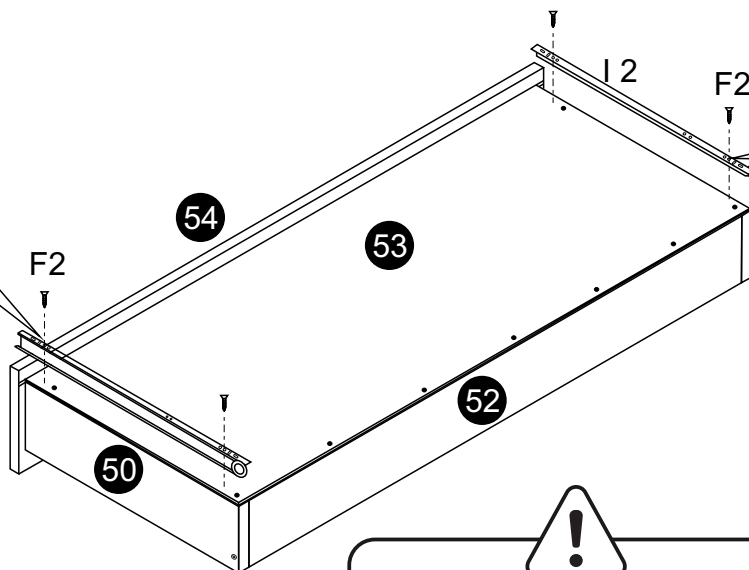
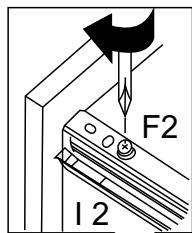

Place the slide in front of the drawer.  
Coloque la corredera frente al cajón.  
Encostar a corredeira na frente da gaveta.

I2  02 PCS

F14  04 PCS

07

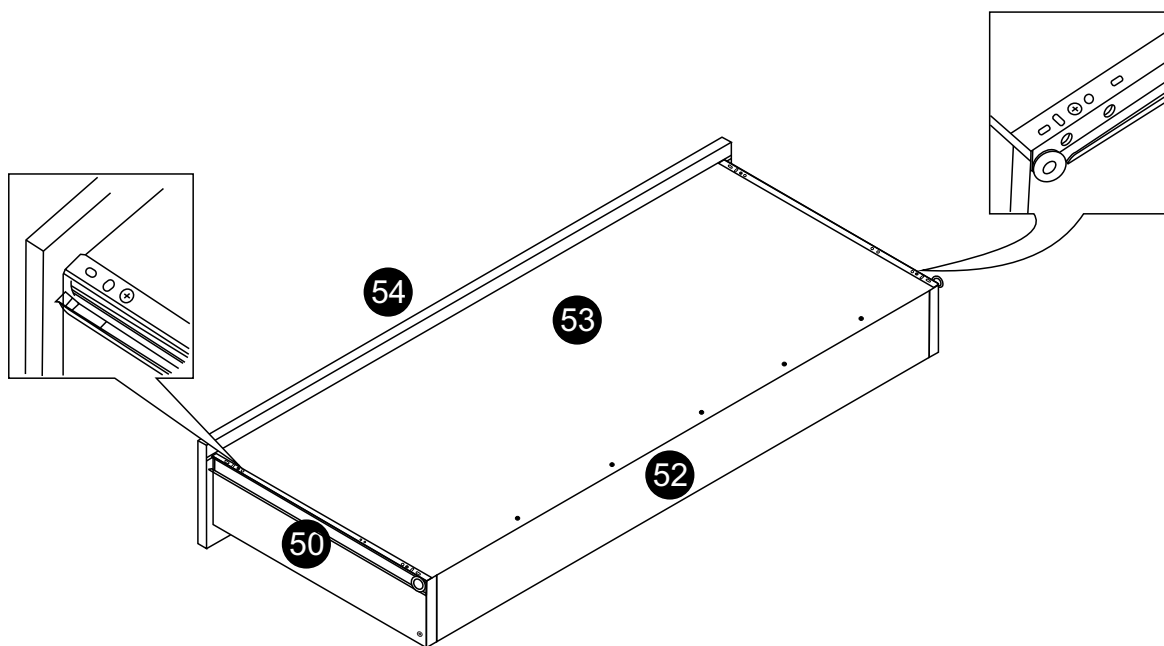



08

Anti tipping kit - Follow the instructions in the included manual

Kit Antivuelco - Siga el manual del producto

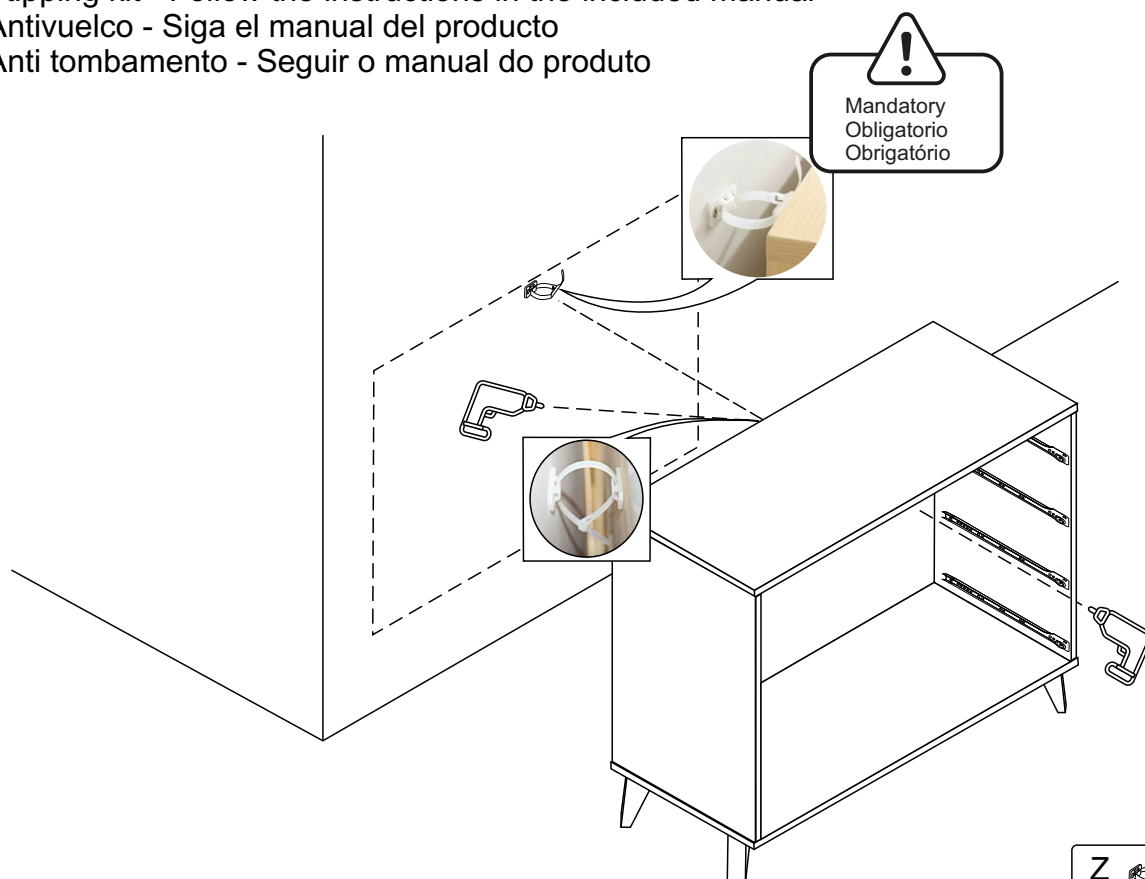
Kit Anti tombamento - Seguir o manual do produto



Z  01 PCS

09

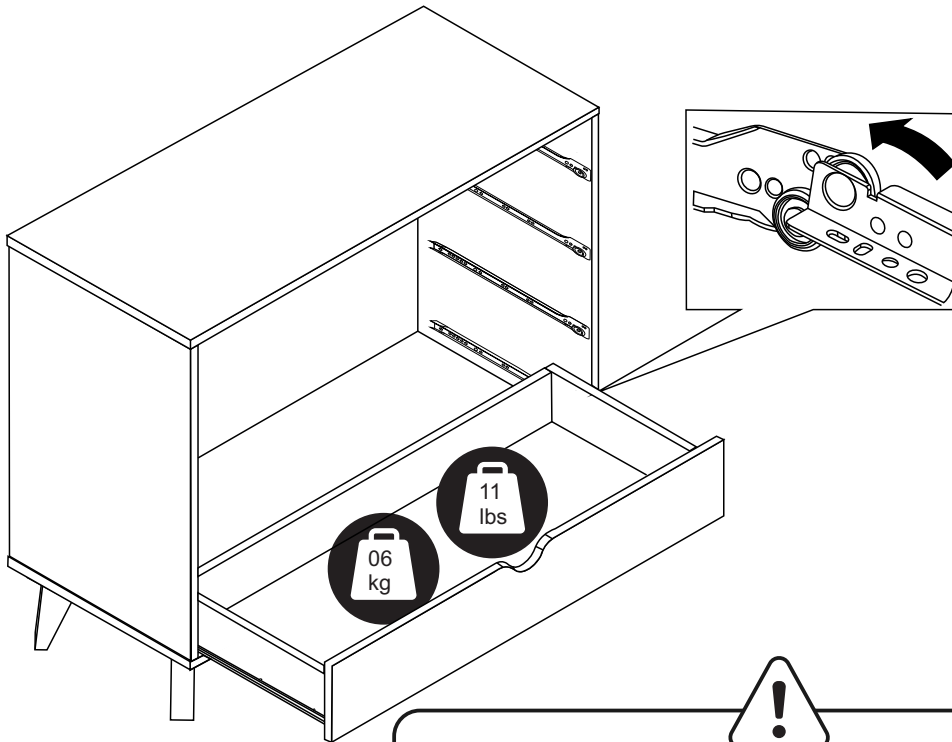

- **Before using the drawer, let it dry for 4 hours.**
- **Antes de usar el cajón, déjelo secar durante 4 horas.**
- **Antes da utilização da gaveta, deve-se deixar secando por 04 horas.**

10

First drawer attention sticker  
 Adhesivo atención primer cajón  
 Adesivo de atenção para primeira gaveta

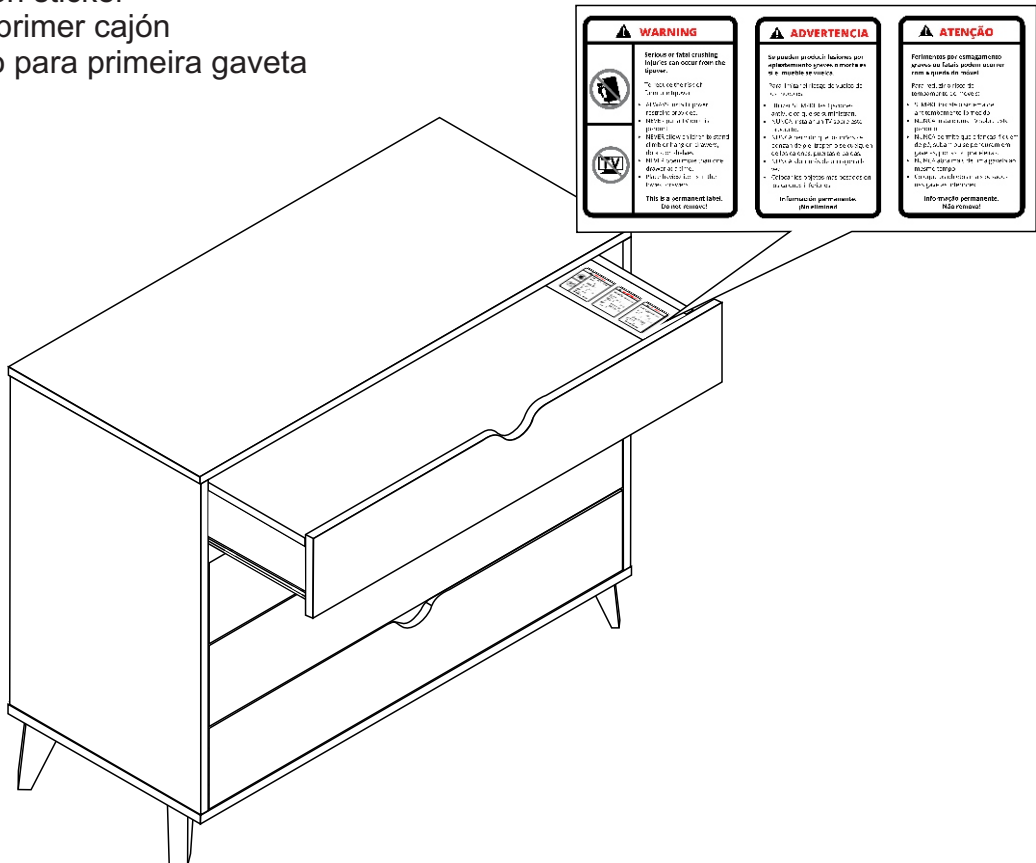

11

Finished  
Acabado  
Finalizado

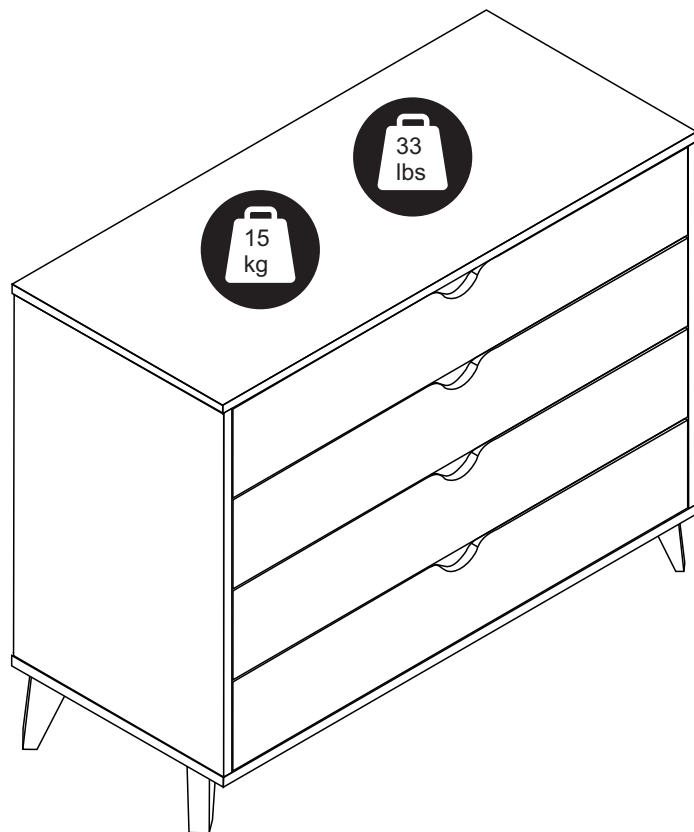



Serious or fatal crushing injuries can occur from the tipover.

To reduce the risk of furniture tipover:

- ALWAYS install tipover restraint provided.
- NEVER put a TV on this product.
- NEVER allow children to stand, climb or hang on drawers, doors or shelves.
- NEVER open more than one drawer at a time.
- Place heaviest items in the lowest drawers.

This is a permanent label.  
Do not remove!



Riesgo de aplastamiento graves o fatales en caso de caídas de los muebles.

Para reducir el riesgo de que los muebles se vuelquen:

- Instale siempre el sistema antivuelco proporcionado.
- NUNCA instale una TELE en este producto.
- NUNCA permita que los niños se paren, trepen o cuelguen de cajones, puertas o estantes.
- NUNCA abra más de un cajón al mismo tiempo.
- Coloque los objetos más pesados en los cajones inferiores.

Información permanente.  
¡No retires!



Ferimentos por esmagamentos graves ou fatais podem ocorrer com a queda do móvel.

Para reduzir o risco de tombamento de móveis:

- SEMPRE instale o sistema de antitombamento fornecido.
- NUNCA instale uma TV sobre esse produto.
- NUNCA permita que crianças fiquem em pé, subam ou se pendurem em gavetas, portas ou prateleiras.
- NUNCA abra mais de uma gaveta ao mesmo tempo.
- Coloque os objetos mais pesados nas gavetas inferiores.

Informação permanente.  
Não remova!