

---

**HALL TREE**  
**PATÈRE AVEC RANGEMENT**  
**PERCHERO CON BAÚL**

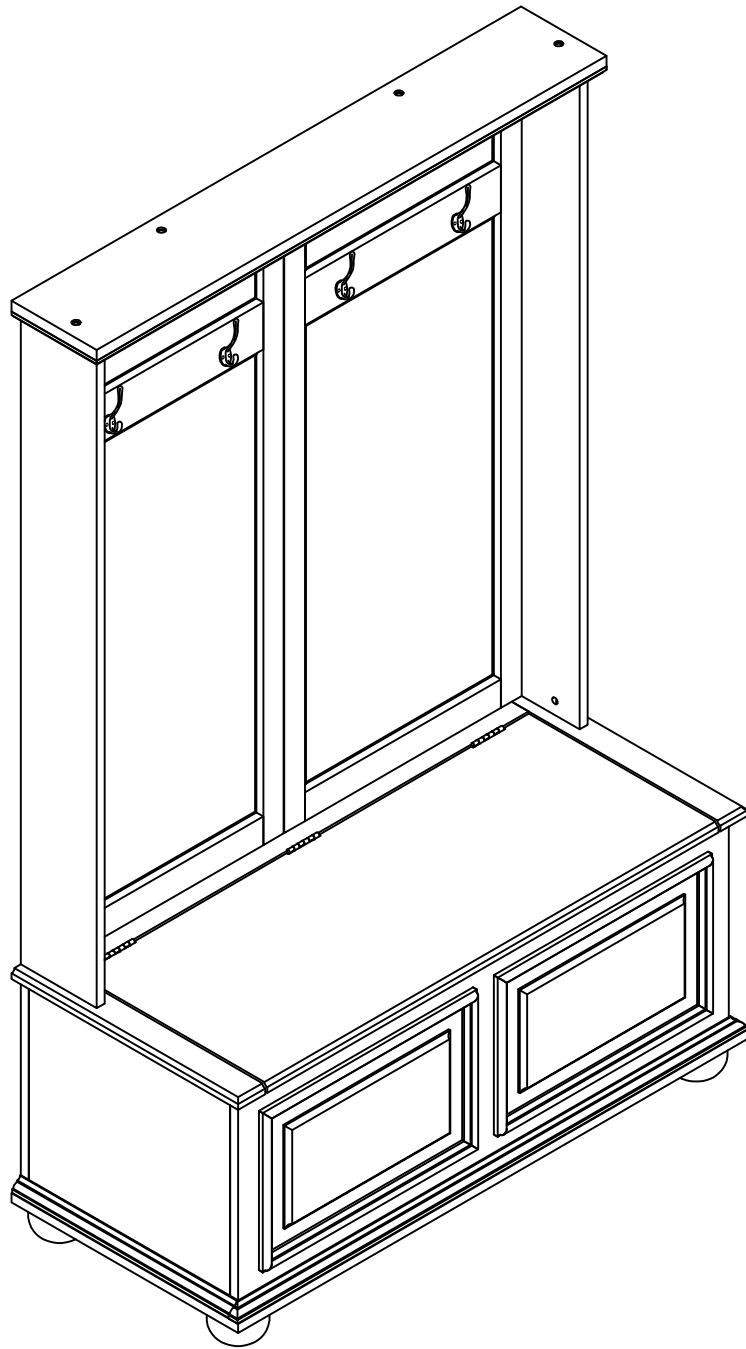











---

**We are here to help!**  
**Before you return it - contact us.**

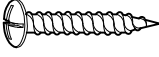
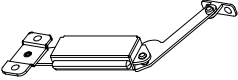
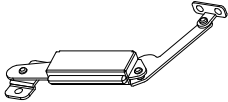
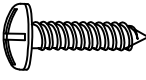
**Nous sommes là pour vous aider!**  
**Avant de retourner le produit, veuillez communiquer avec nous.**

**¡Estamos aquí para ayudarle!**  
**Antes de regresar el producto, comuníquese con nosotros.**

## HARDWARE LIST

				
H1 x 43 (Ø8x30mm)	H2 x 18 (Ø1/4"xL11mm)	H3 x 14 (Ø1/4"x50mm)	H4 x 19 (Ø1/4"x30mm)	H5 x 4 (Ø1/4"x38mm)
				
H6 x 2 (Ø4x1")	H7 x 01	H8 x 01	H9 x 08 (Ø4x1/2")	H10 x 04
				
H11 x 08 (Ø3.5x5/8")	H12 x 01	H13 x 01 (Not Provided) (Non Fourni) (No Suministrado)	H14 x 01 (Not Provided) (Non Fourni) (No Suministrado)	

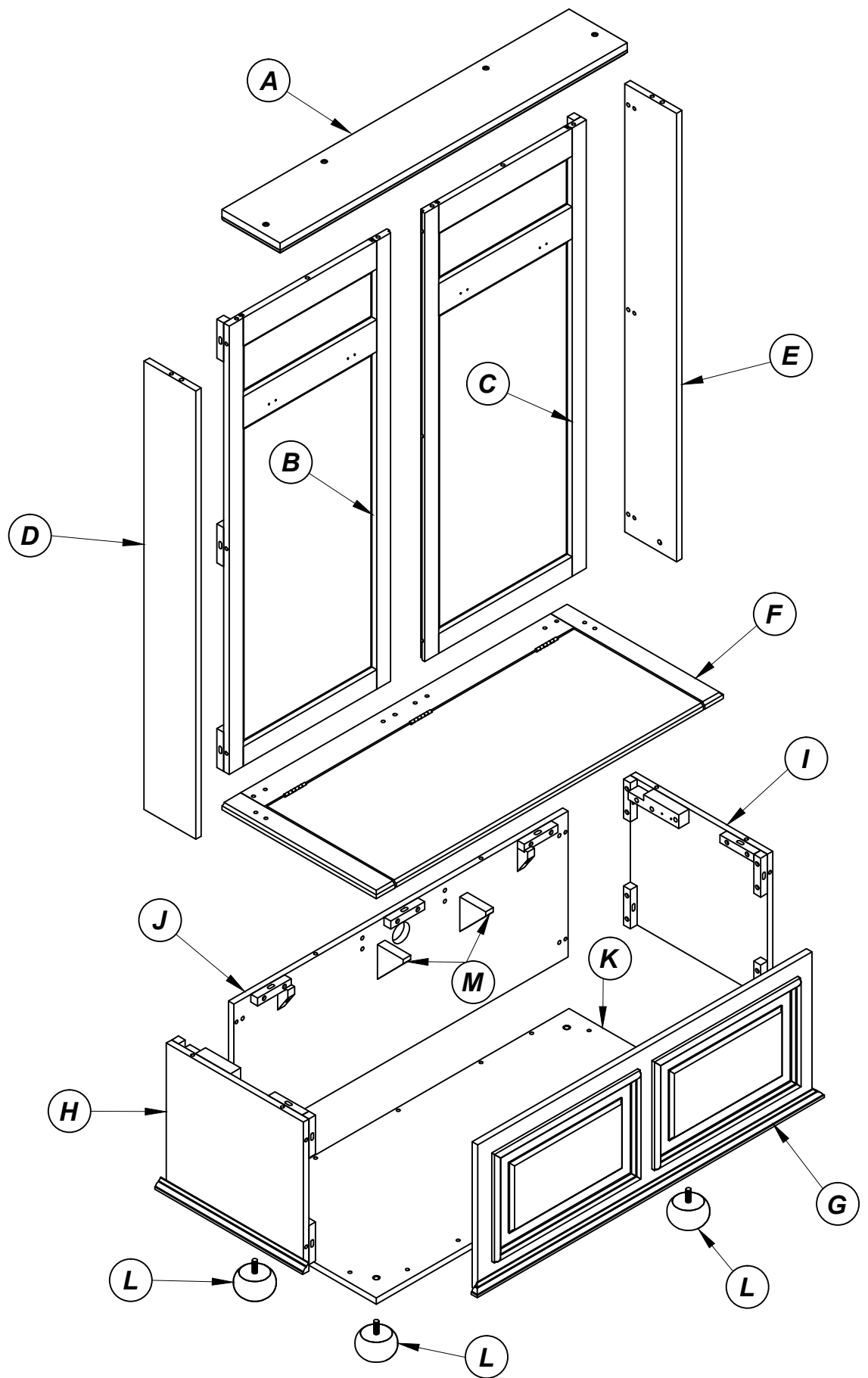

## PART LIST

PARTS	DESCRIPTION	QTY
<b>A</b>	TOP PANEL	<b>01</b>
<b>B</b>	LEFT BACK FRAME	<b>01</b>
<b>C</b>	RIGHT BACK FRAME	<b>01</b>
<b>D</b>	LEFT SIDE RAIL	<b>01</b>
<b>E</b>	RIGHT SIDE RAIL	<b>01</b>
<b>F</b>	SEAT	<b>01</b>
<b>G</b>	FRONT FRAME	<b>01</b>
<b>H</b>	LEFT SIDE FRAME	<b>01</b>
<b>I</b>	RIGHT SIDE FRAME	<b>01</b>
<b>J</b>	BACK FRAME	<b>01</b>
<b>K</b>	BOTTOM PANEL	<b>01</b>
<b>L</b>	LEG	<b>04</b>
<b>M</b>	CLEAT	<b>02</b>



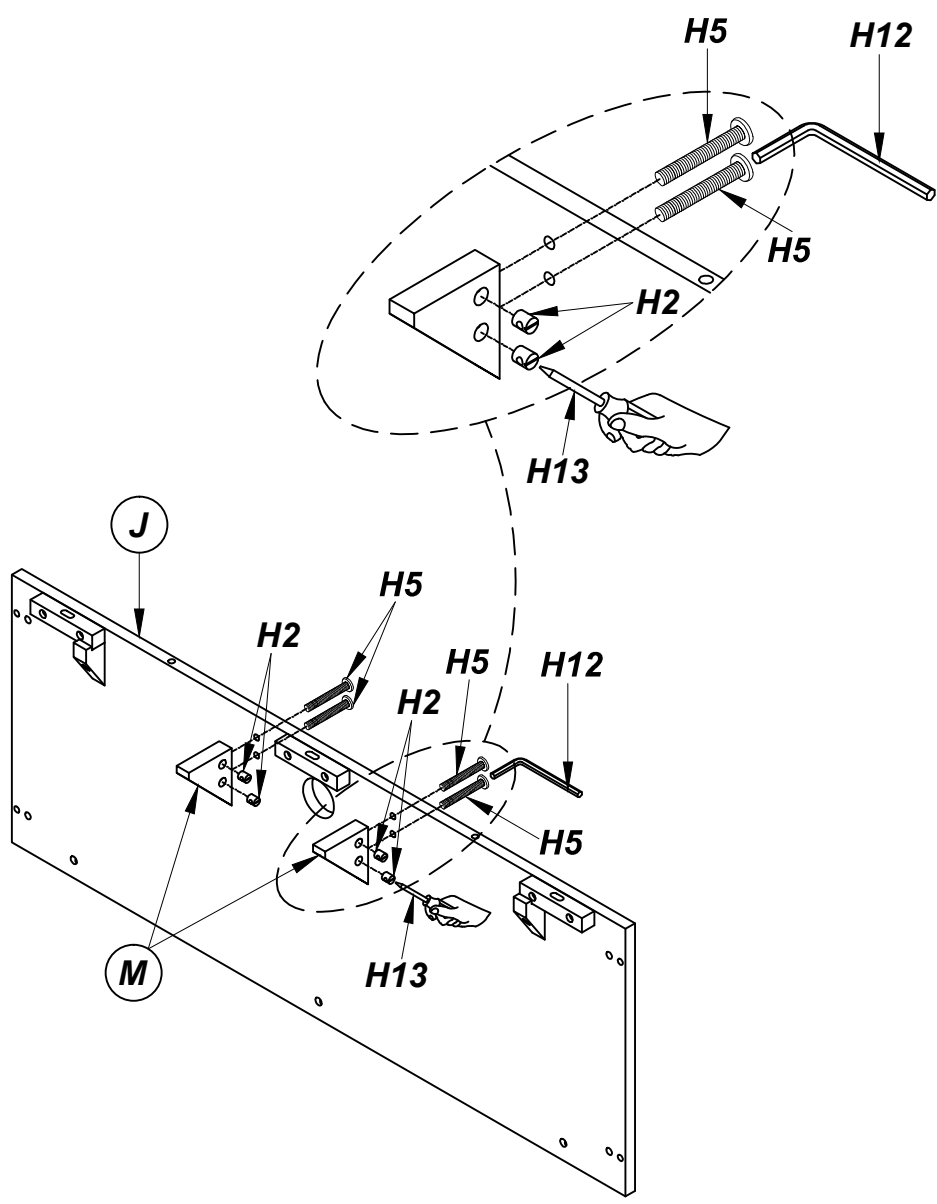

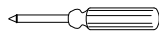

STEP 1  
 ÉTAPE 1  
 PASO 1

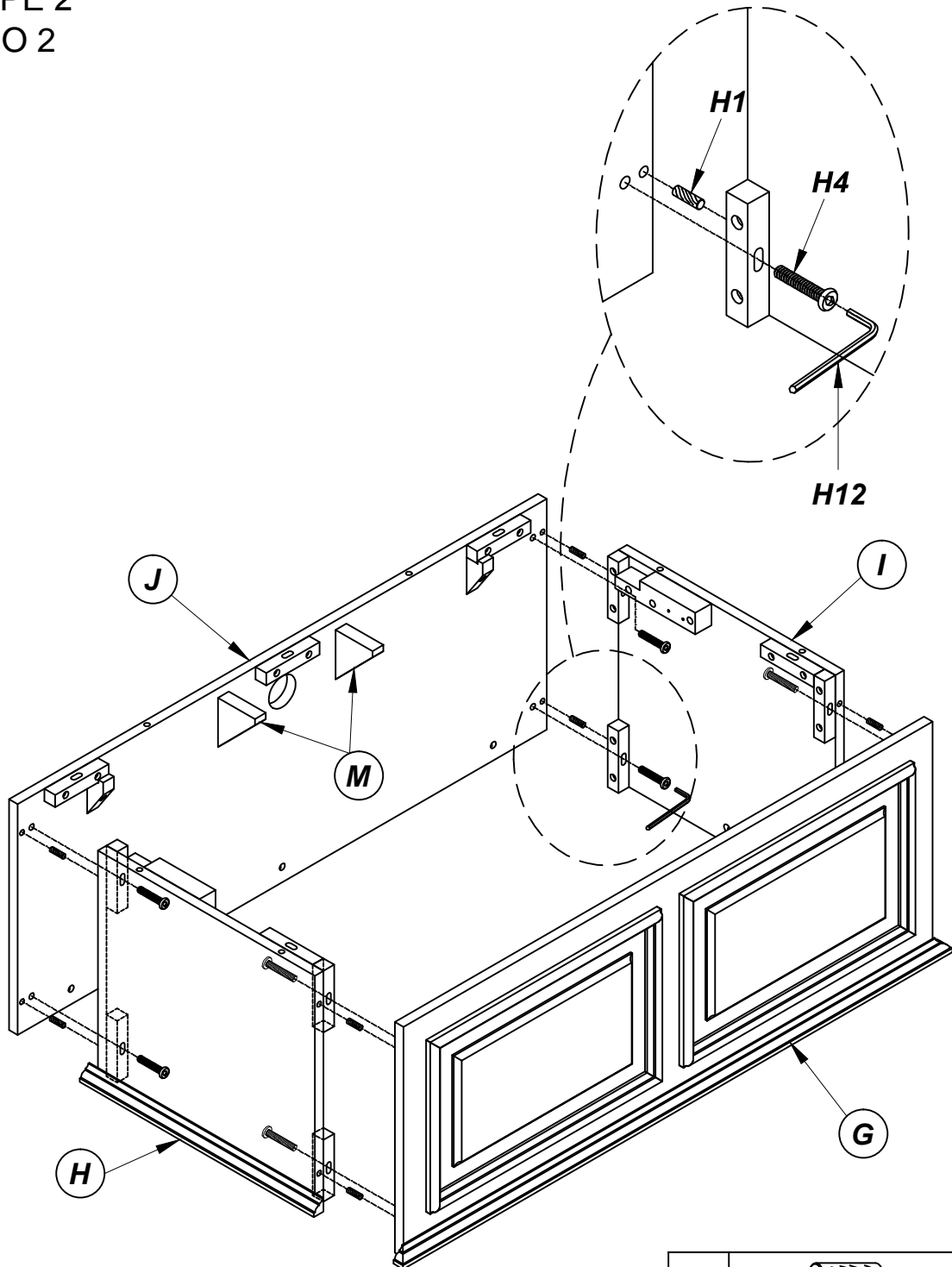

H2		04
H5		04
H12		01
H13	 (Not Provided)	01





STEP 2  
 ÉTAPE 2  
 PASO 2

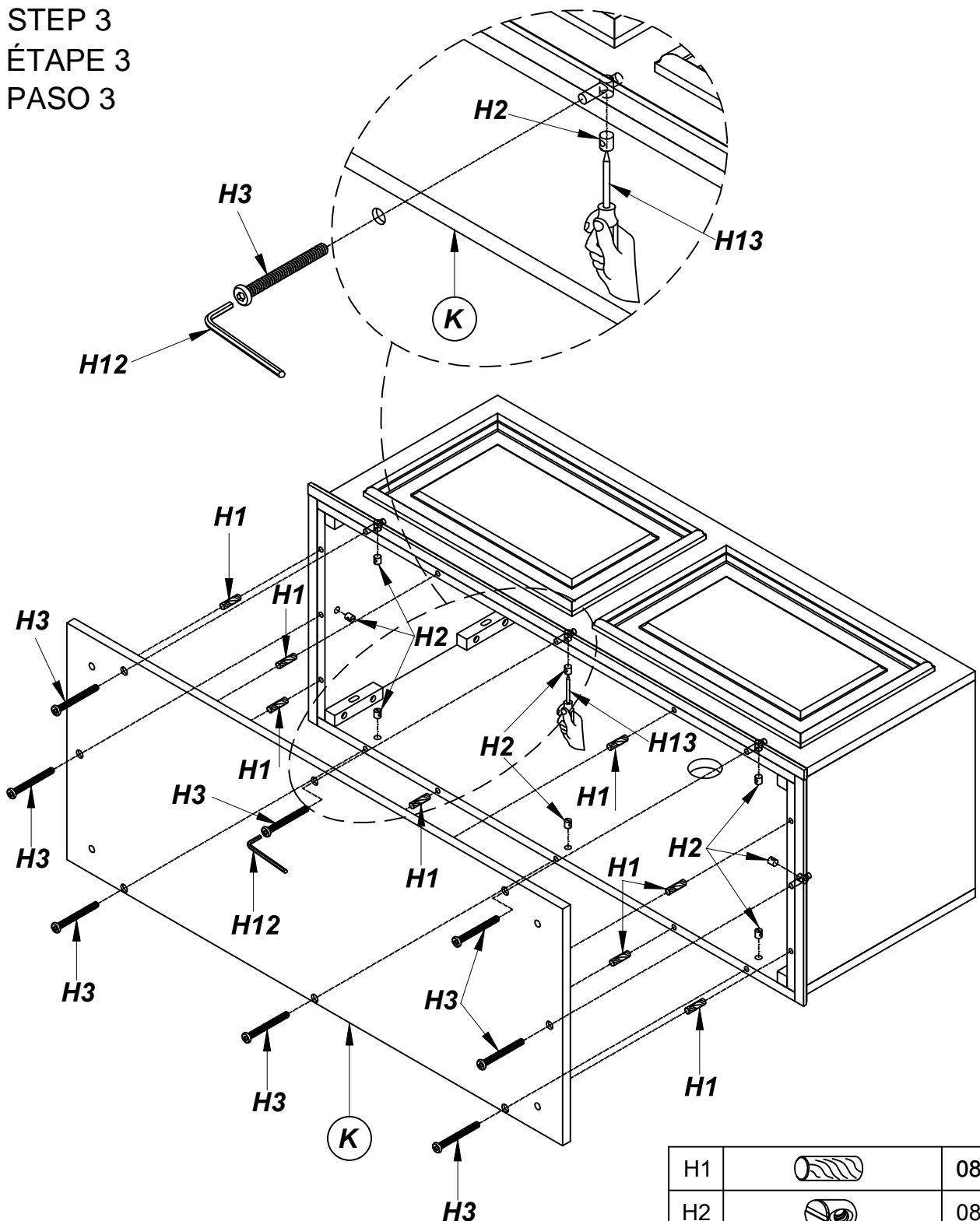

H1		08
H4		08
H12		01

STEP 3  
ÉTAPE 3  
PASO 3



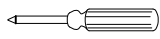

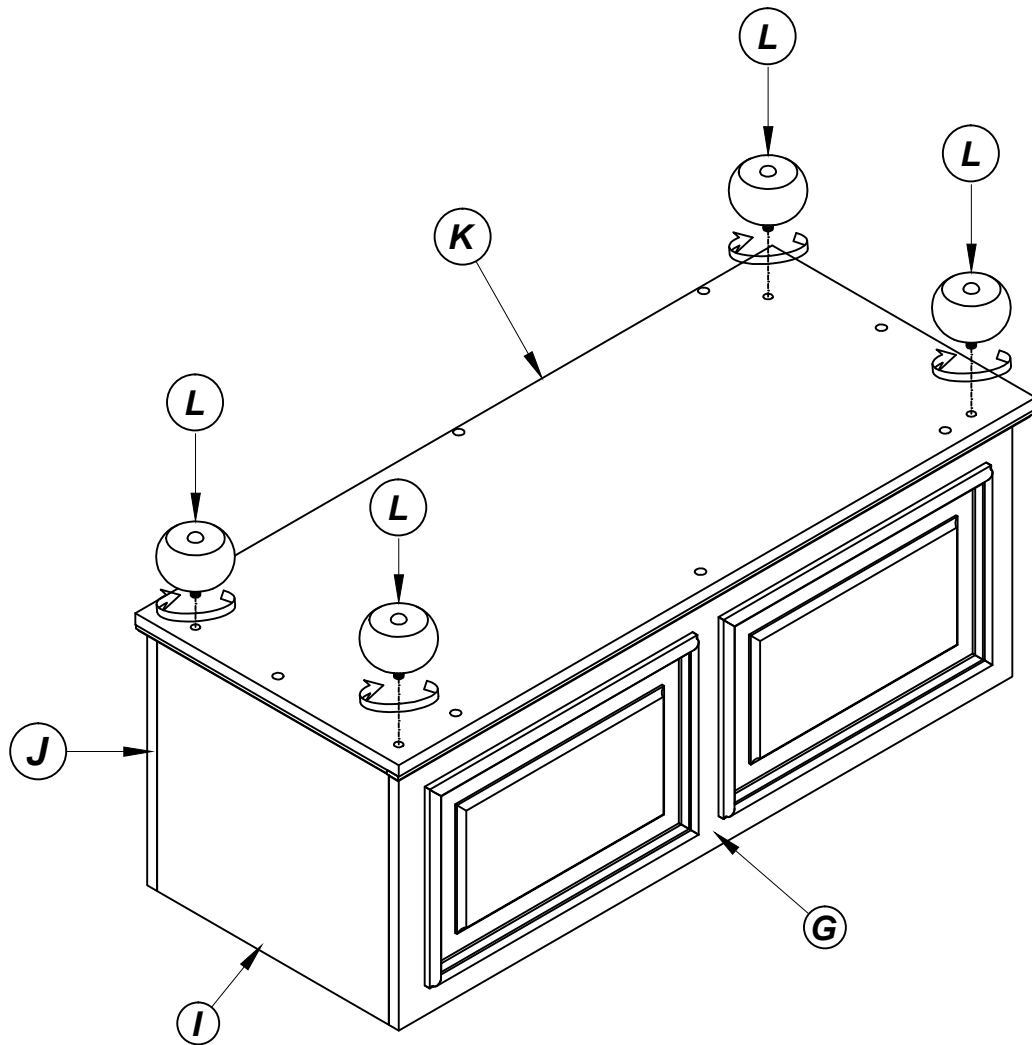

H1		08
H2		08
H3		08
H12		01
H13	 (Not Provided)	01

STEP 4  
ÉTAPE 4  
PASO 4

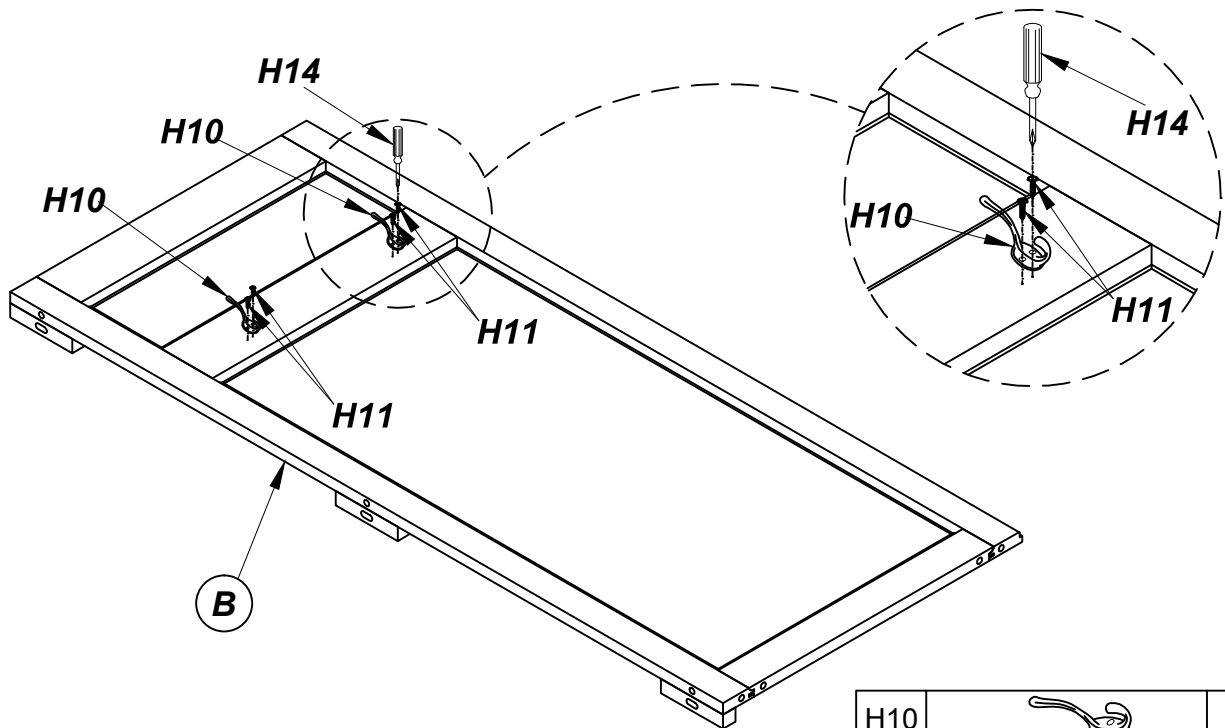
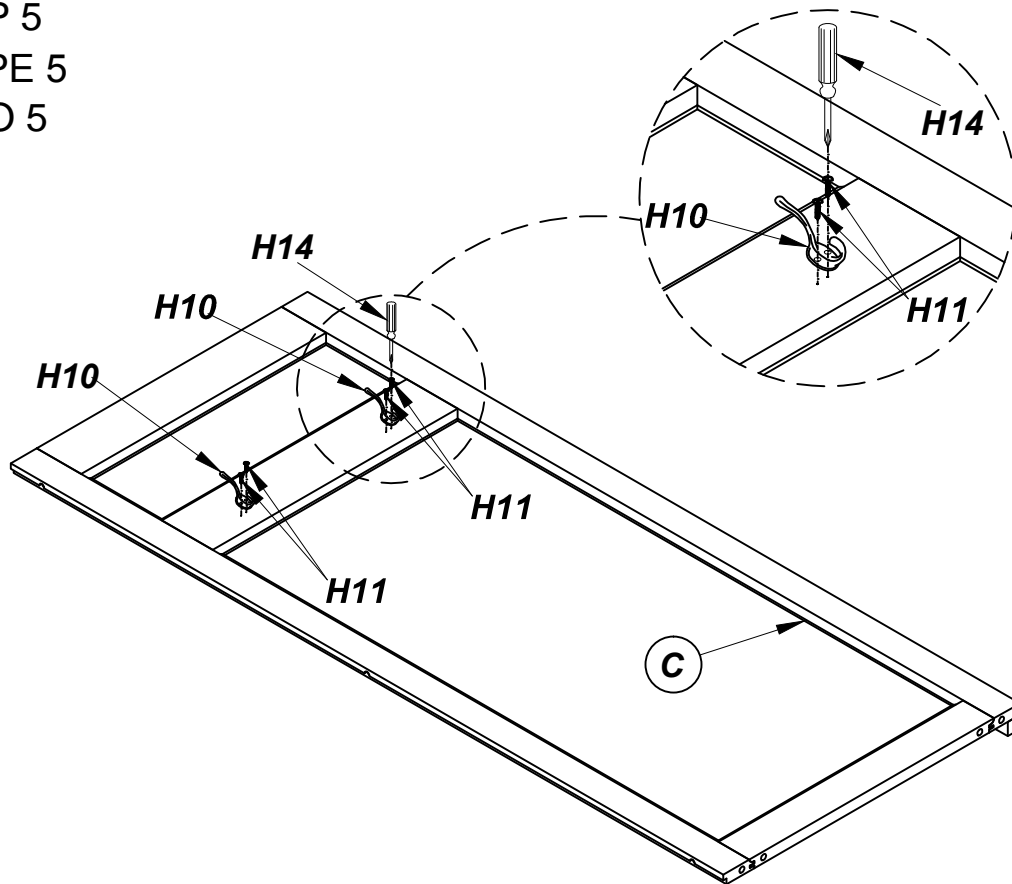

STEP 5  
ÉTAPE 5  
PASO 5



H10		04
H11		08
H14	 (Not Provided)	01

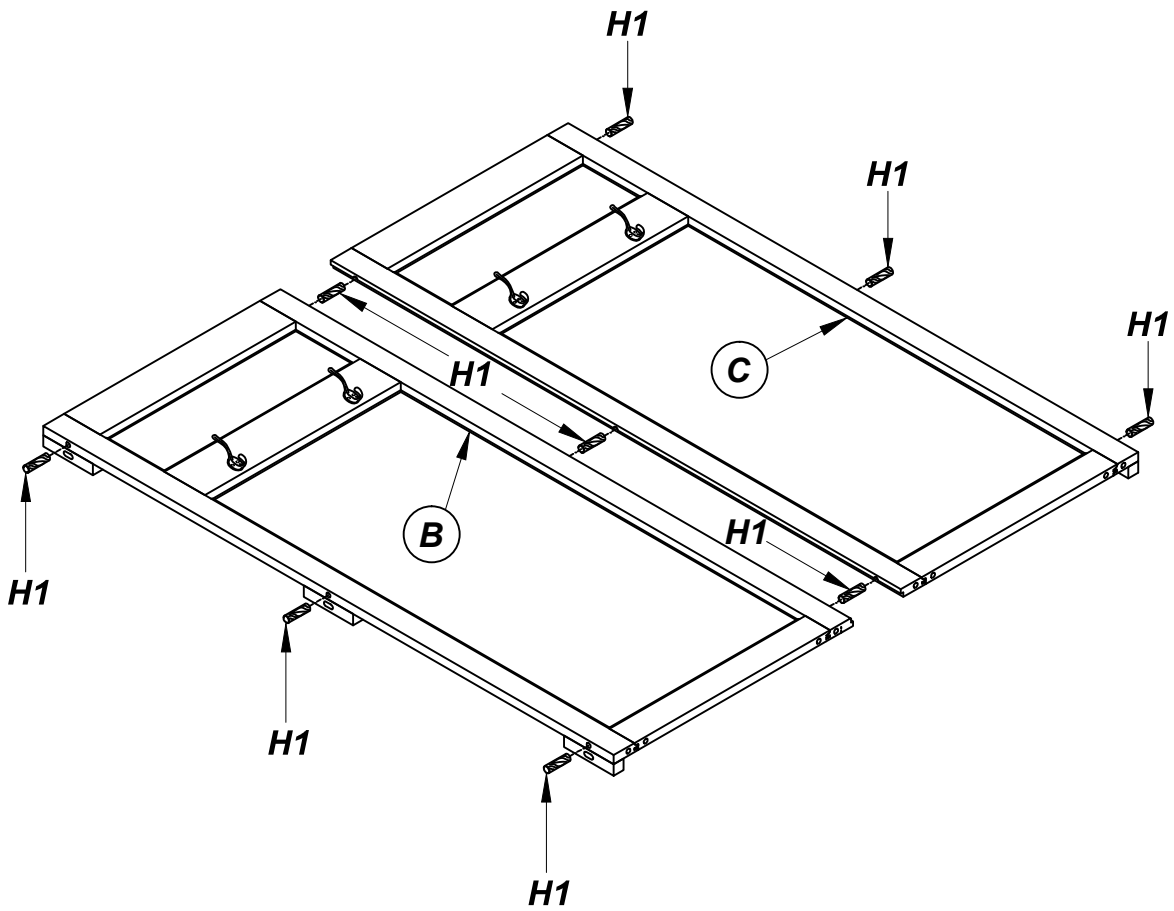

STEP 6  
ÉTAPE 6  
PASO 6



H1		09
----	---	----

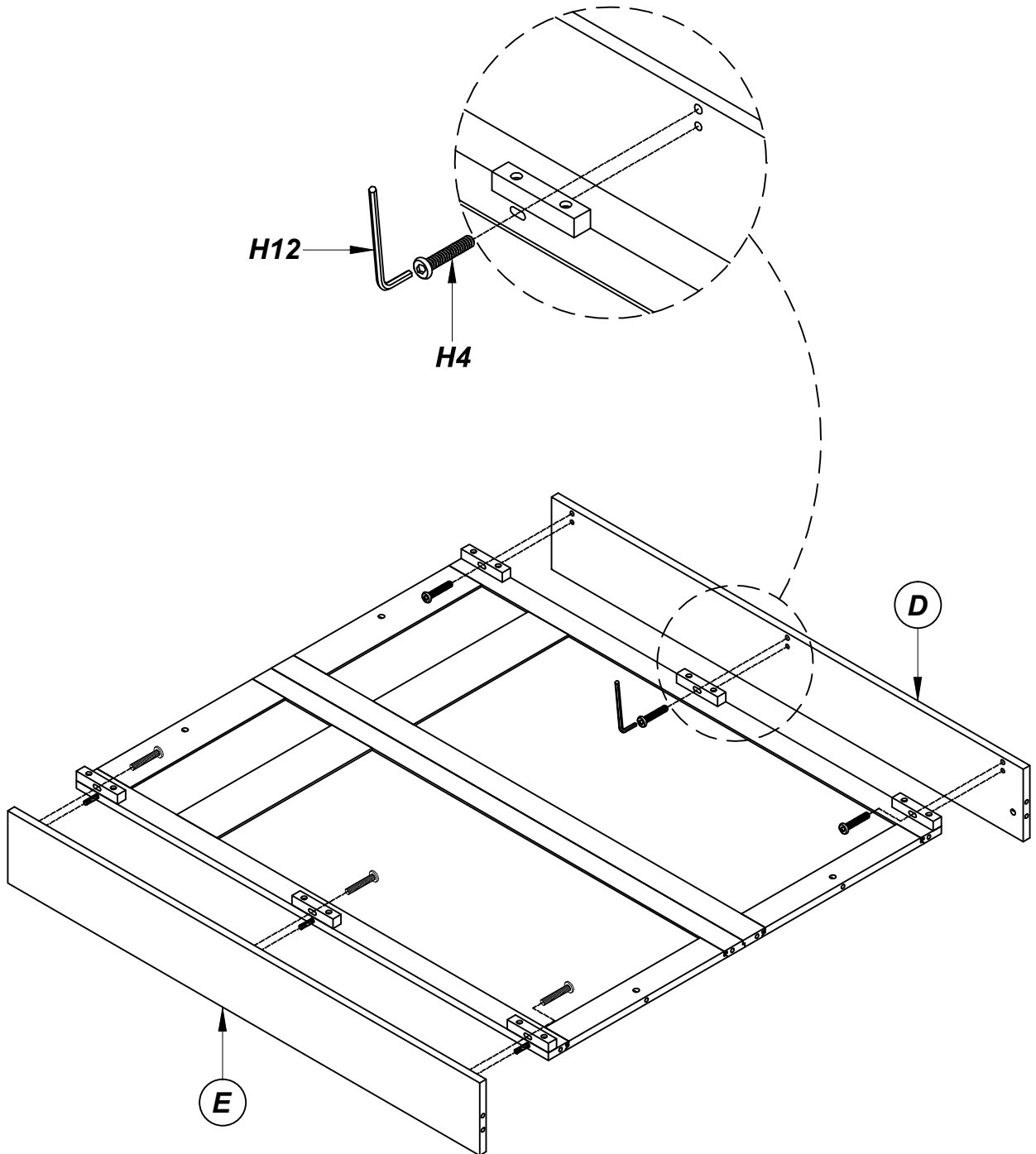



STEP 7  
ÉTAPE 7  
PASO 7

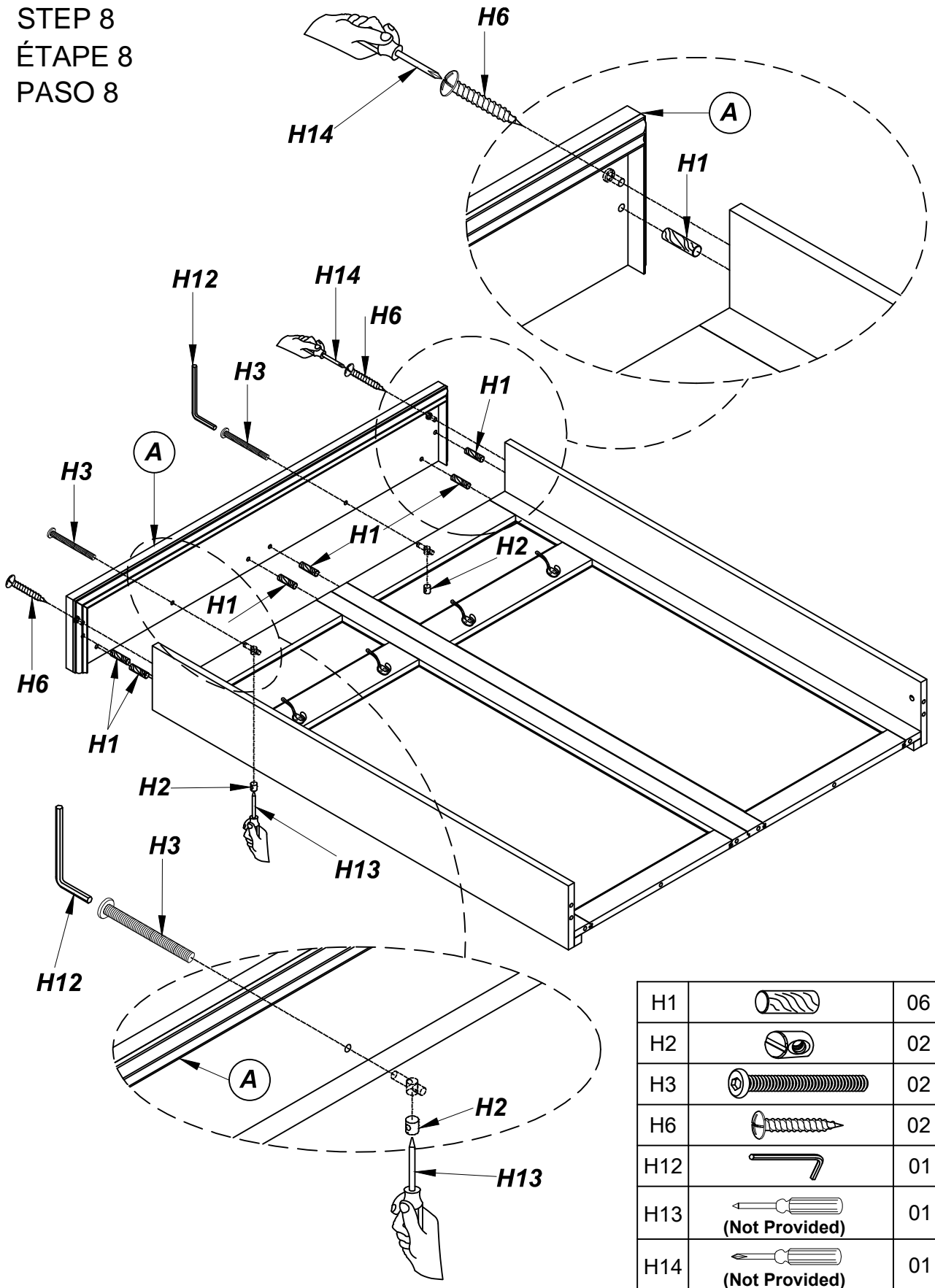

H4		06
H12		01



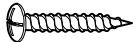

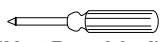
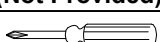
STEP 8  
ÉTAPE 8  
PASO 8

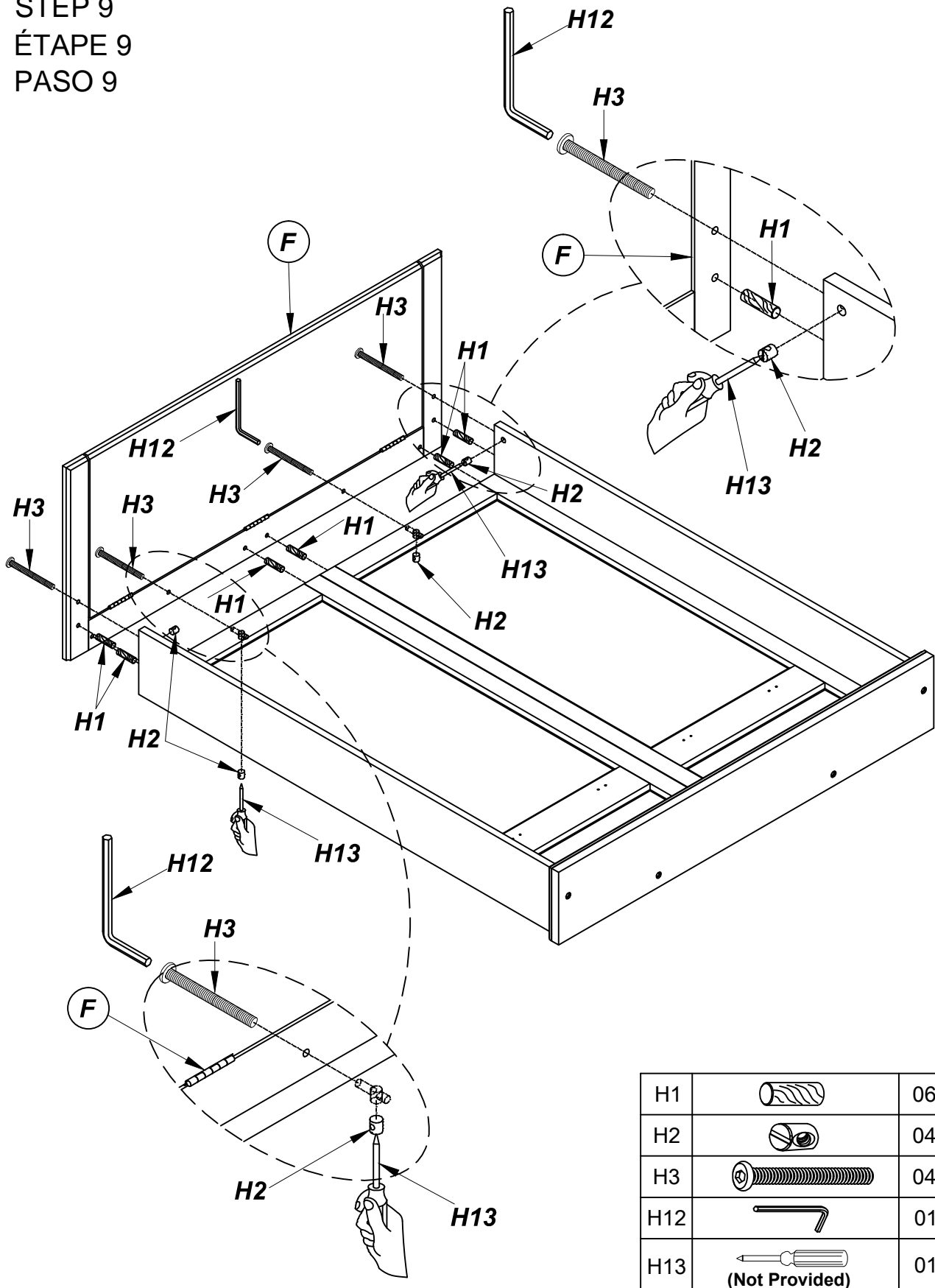

H1		06
H2		02
H3		02
H6		02
H12		01
H13	 (Not Provided)	01
H14	 (Not Provided)	01



STEP 9  
ÉTAPE 9  
PASO 9

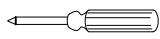

H1		06
H2		04
H3		04
H12		01
H13	 (Not Provided)	01

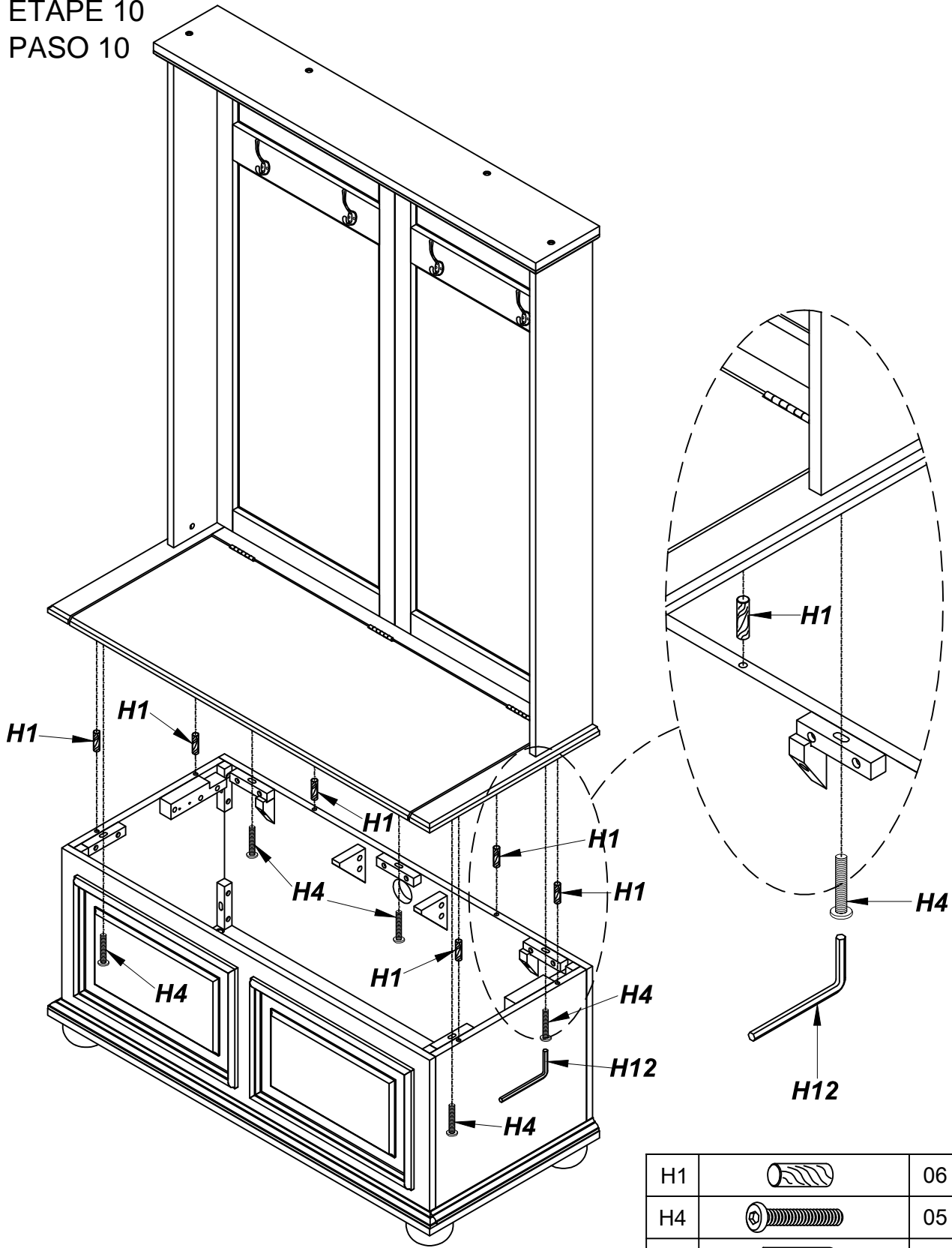

STEP 10  
 ÉTAPE 10  
 PASO 10

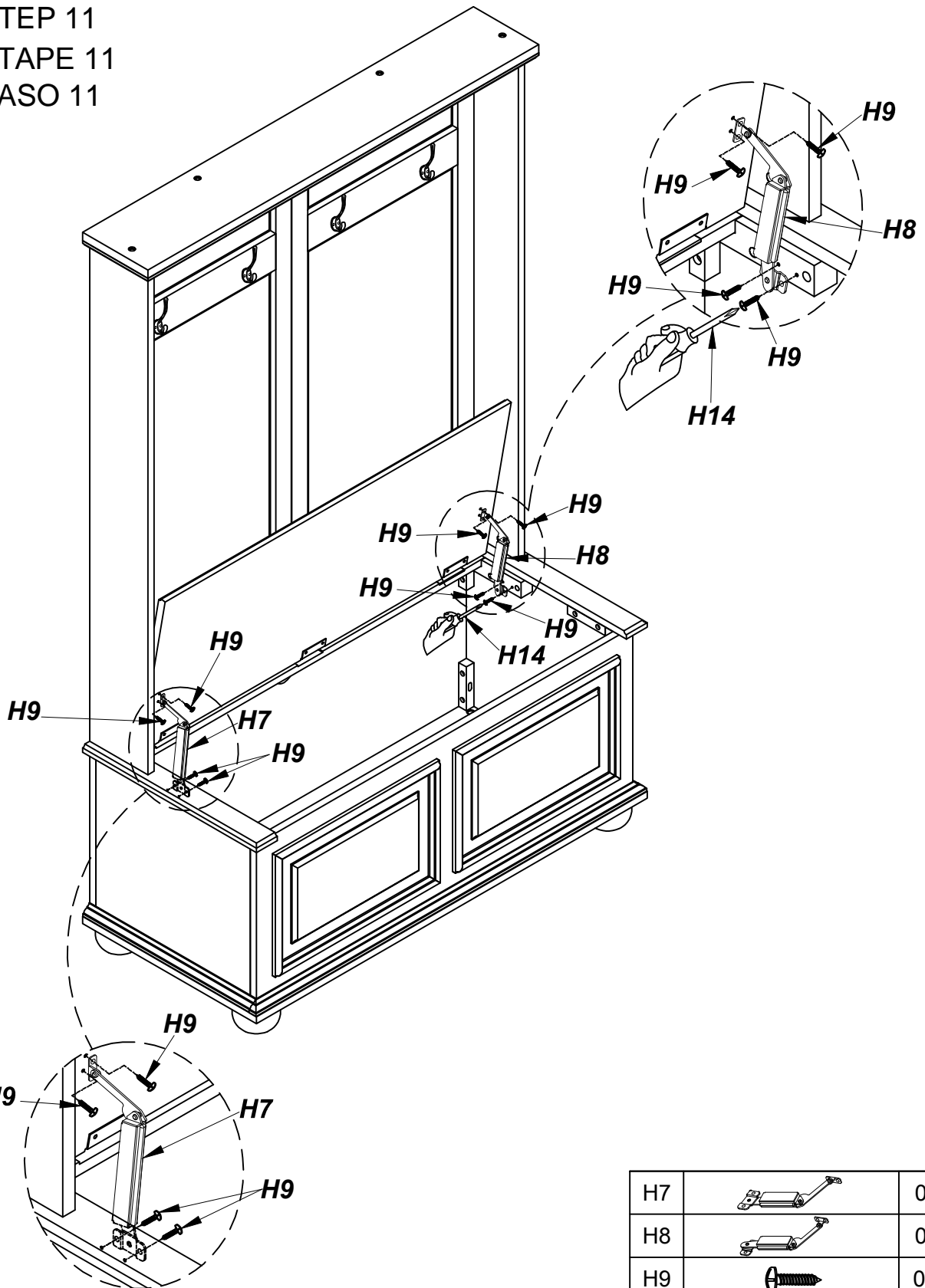

H1		06
H4		05
H12		01

STEP 11  
 ÉTAPE 11  
 PASO 11

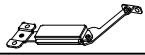
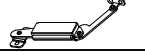

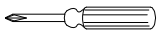
H7		01
H8		01
H9		08
H14	 (Not Provided)	01

---

**LIMITED WARRANTY**  
**GARANTIE LIMITÉE**  
**GARANTÍA LIMITADA**

MADE IN VIETNAM  
FABRIQUÉ AU VIETNAM  
HECHO EN VIETNAM

### ⚠ WARNING

Serious or fatal crushing injuries can occur from furniture tipover. To help prevent tip-over:

- Install tipover restraint provided.
- Place heaviest items in the lower drawers.
- Unless specifically designed to accommodate, do not set TV's or other heavy objects on the top of this product.
- Never allow children to climb or hang on drawers, doors, or shelves.
- Never open more than one drawer at a time (OR).
- Do not defeat or remove the drawer interlock system.

Use of tipover restraints may only reduce, but not eliminate, the risk of tipover.

*This is a permanent label. Do not remove!*

### ⚠ AVERTISSEMENT

Le basculement du meuble peut cause de graves blessures par écrasement, voire la mort. Pour empêcher le basculement :

- Installer les dispositifs antibasculement fournis.
- Ranger les articles les plus lourds dans les tiroirs du bas.
- À moins qu'il ne soit conçu à cet effet, éviter de placer un téléviseur ou un objet lourd sur le dessus de ce meuble.
- Ne jamais permettre à des enfants de monter sur les tiroirs, portes ou tablettes, ni de s'y suspendre.
- Ne jamais ouvrir plus d'un tiroir à la fois.
- Ne pas altérer ni retirer le système de verrouillage du tiroir.

L'utilisation d'un dispositif antibasculement ne peut que diminuer, et non éliminer, le risque de basculement.

*Cette étiquette est permanente. Ne pas tenter de l'enlever!*

### ⚠ ADVERTENCIA

El vuelco del mueble puede causar lesiones por aplastamiento e incluso la muerte. Para evitar que el mueble se vuelque :

- Instale los dispositivos antivuelco proporcionados.
- Guarde los artículos más pesados en los cajones inferiores.
- Evite colocar un televisor o un objeto pesado encima del mueble, salvo si éste último ha sido diseñado específicamente para dicho fin.
- No permita que los niños suban sobre los cajones, las puertas o los estantes ni que se cuelguen de dichas piezas.
- No abra más de un cajón a la vez.
- No altere ni quite el sistema de cerradura del cajón.

El uso de un dispositivo antivuelco sólo disminuye el riesgo de vuelco, no lo elimina.

*Esta etiqueta es permanente. No trate de quitarla!*



Strap  
A (1pc)



Mounting Bracket  
B (2pcs)

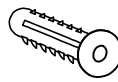

Wall Anchor  
C (2pcs)



Short Screw  
D (2pcs)

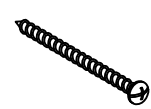

Long Screw  
E (2pcs)

Step 1: Put wall anchor (C) into the wall and attach mounting bracket (B) to the wall with long screw (E).

PLEASE NOTE: For your safety, to prevent the danger of this unit tipping over, it is important that the wall anchor are properly attached.

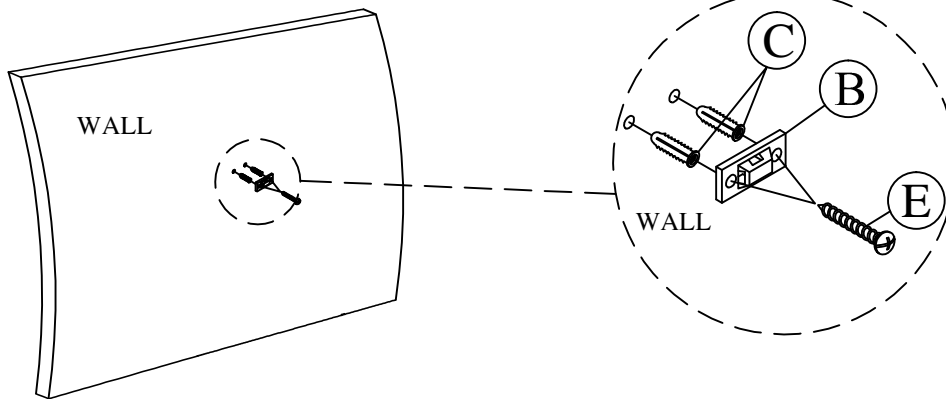

Step 2: Attach mounting bracket (B) to the back of the vanity with short screw (D).

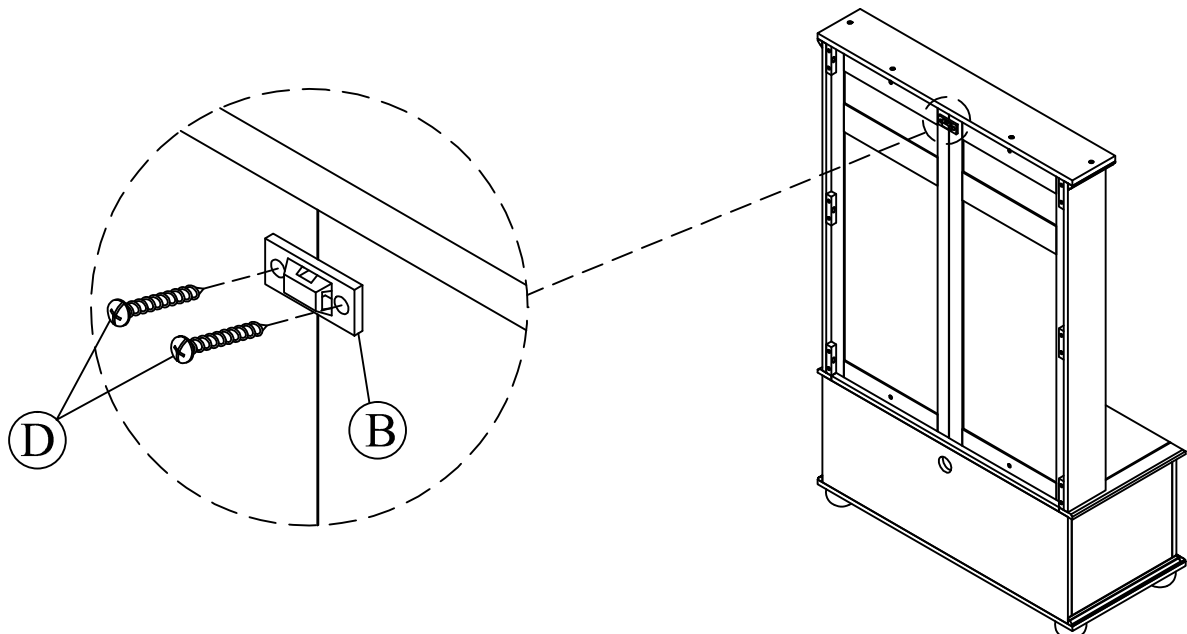

Step 3: Slide the strap (A) through the mounting brackets and pull to tighten the Hall Tree snug against the wall.

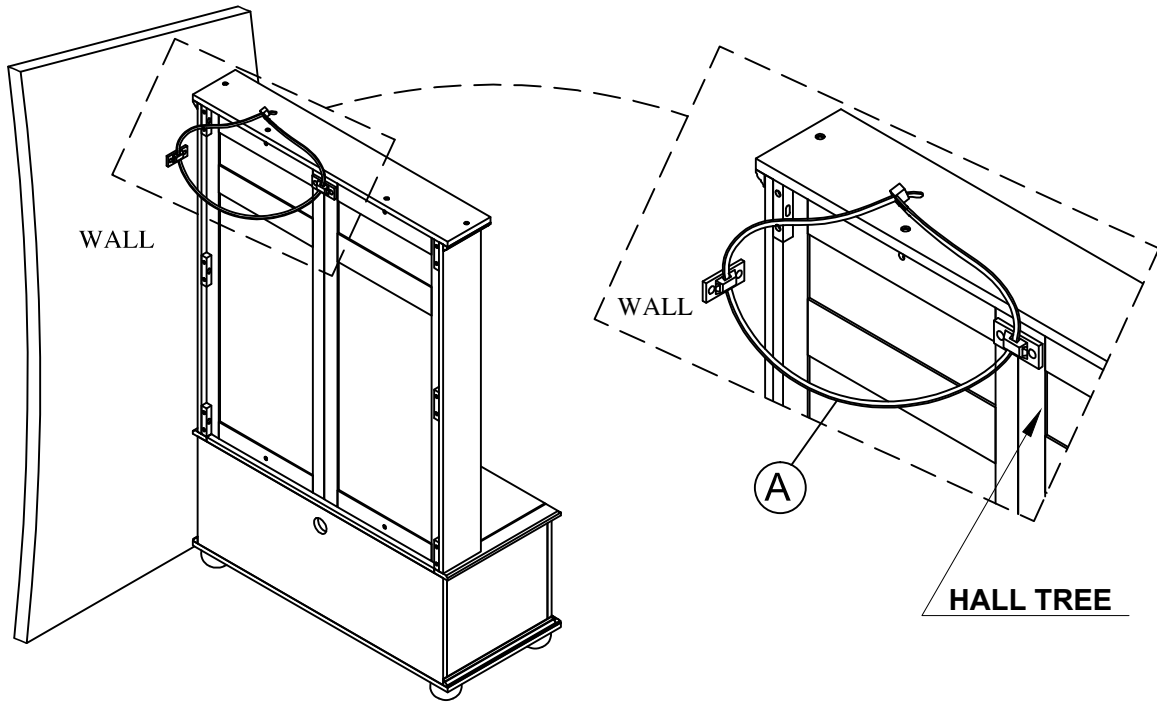

## COMPLETED ASSEMBLY

