

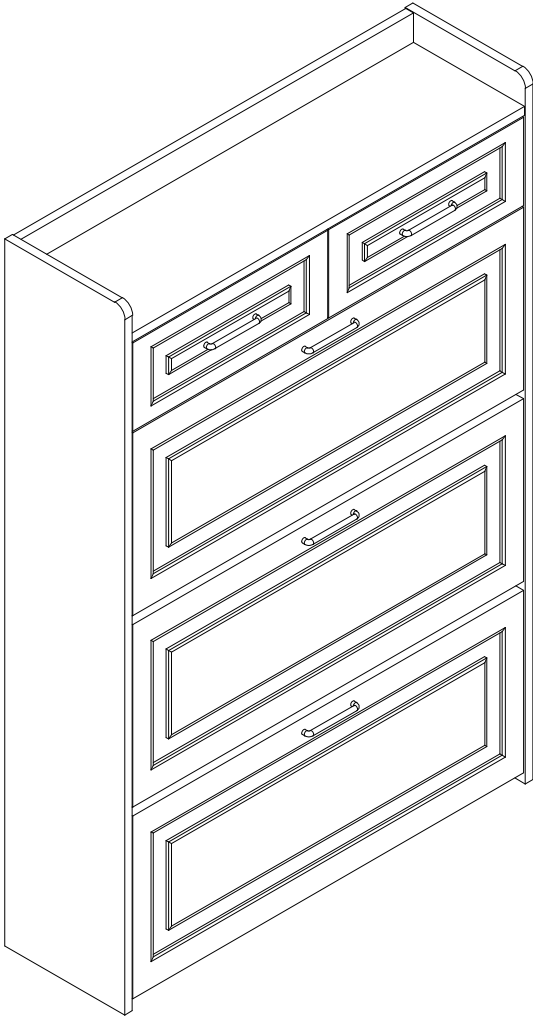



Installation & Assembly



 2PERS	 60 MIN	Tool Required Not Provided	
			  

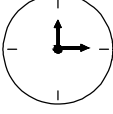
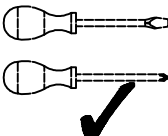

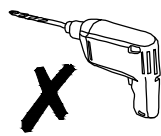
[DE]

Warnung: Lesen Sie die Anleitung vor dem Zusammenbau bitte vollständig durch. Überprüfen Sie, ob Sie alle auf den Seiten aufgeführten Komponenten und Werkzeuge haben.

Warnung: Legen Sie alle Teile auf eine ebene Fläche. Legen Sie eine weiche Decke oder Ähnliches darunter, um sie vor Kratzern oder Flecken zu schützen. Vermeiden Sie es, Komponenten über den Boden zu ziehen oder zu schieben.

Warnung: Überprüfen Sie regelmäßig alle Beschläge und Befestigungen, um sicherzustellen, dass sie sicher sind und um Unfälle zu vermeiden. Wenn Teile fehlen, kaputt, beschädigt oder abgenutzt sind, verwenden Sie das Produkt nicht weiter, bis es mit vom Hersteller autorisierten Teilen repariert wurde.

Warnung: Lassen Sie Kinder nicht auf die Möbel klettern, da dies zum Umkippen und zu schweren Verletzungen führen kann. Bauen Sie die Möbel außerhalb der Reichweite von Kindern zusammen.

Warnung: Stellen Sie die Möbel nicht in die Nähe von Feuerquellen oder heißen Gegenständen, um Brandgefahr zu vermeiden.

Warnung: Reinigen Sie die Möbel mit einem feuchten Tuch oder Alkohol. Verwenden Sie keine Reinigungsmittel mit ätzenden Chemikalien.

Warnung: Dieses Produkt ist mit einer Kippschutzvorrichtung ausgestattet. Bitte installieren Sie diese Vorrichtung unbedingt, um unnötige Verletzungen durch Umkippen zu vermeiden.

[EN]

Warning: Please read instructions fully before starting assembly. Check you have all the components and tools listed on pages.

Warning: Please place all parts on a flat surface. Place a soft blanket or similar underneath to protect against scratches or stains. Avoid dragging or sliding components across the floor.

Warning: Regularly check all fittings and fastenings to ensure they are secure and to prevent accidents. If any parts are missing, broken, damaged, or worn, discontinue use of the product until repairs have been made using factory authorized parts.

Warning: Do not allow children to climb on the furniture as this may result in tipping and serious personal injury. Assemble the furniture away from the reach of children.

Warning: Do not place furniture close to fire sources or high-temperature objects to avoid the risk of fire.

Warning: Clean furniture with a damp cloth or alcohol, avoid using cleaning agents containing corrosive chemicals.

Warning: This product is equipped with an anti-tilt device. Please be sure to install this device to prevent unnecessary injuries caused by tipping.

[FR]

Avertissement : Veuillez lire entièrement les instructions avant de commencer l'assemblage. Vérifiez que vous disposez de tous les composants et outils répertoriés sur les pages.

Avertissement : Veuillez placer toutes les pièces sur une surface plane. Placez une couverture douce ou similaire en dessous pour les protéger des rayures ou des taches. Évitez de faire glisser les composants sur le sol.

Avertissement : Vérifiez régulièrement tous les raccords et fixations pour vous assurer qu'ils sont bien fixés et pour éviter les accidents. Si des pièces manquent, sont cassées, endommagées ou usées, cessez d'utiliser le produit jusqu'à ce que des réparations aient été effectuées à l'aide de pièces autorisées par l'usine.

Avertissement : Ne laissez pas les enfants grimper sur les meubles car cela pourrait entraîner un basculement et des blessures graves. Assemblez les meubles hors de portée des enfants.

Avertissement : Ne placez pas les meubles à proximité de sources de feu ou d'objets à haute température pour éviter tout risque d'incendie.



Avertissement : Nettoyez les meubles avec un chiffon humide ou de l'alcool, évitez d'utiliser des produits de nettoyage contenant des produits chimiques corrosifs.

Avertissement : Ce produit est équipé d'un dispositif anti-basculement. Assurez-vous d'installer ce dispositif pour éviter les blessures inutiles causées par un basculement.

[IT]

Attenzione: leggere attentamente le istruzioni prima di iniziare il montaggio. Verificare di avere tutti i componenti e gli strumenti elencati nelle pagine.

Attenzione: posizionare tutte le parti su una superficie piana. Posizionare una coperta morbida o simile sotto per proteggere da graffi o macchie. Evitare di trascinare o far scivolare i componenti sul pavimento.

Attenzione: controllare regolarmente tutti i raccordi e i dispositivi di fissaggio per assicurarsi che siano sicuri e per prevenire incidenti. Se alcune parti sono mancanti, rotte, danneggiate o usurate, interrompere l'uso del prodotto fino a quando non siano state eseguite le riparazioni utilizzando parti autorizzate dalla fabbrica.

Attenzione: non consentire ai bambini di arrampicarsi sui mobili poiché ciò potrebbe causare ribaltamenti e gravi lesioni personali. Montare i mobili lontano dalla portata dei bambini.

Attenzione: non posizionare i mobili vicino a fonti di fuoco o oggetti ad alta temperatura per evitare il rischio di incendio.

Attenzione: pulire i mobili con un panno umido o alcol, evitare di utilizzare detergenti contenenti sostanze chimiche corrosive.

Attenzione: questo prodotto è dotato di un dispositivo antiribaltamento. Assicurarsi di installare questo dispositivo per prevenire lesioni inutili causate dal ribaltamento.

[ES]

Advertencia: Lea las instrucciones completamente antes de comenzar el montaje. Compruebe que tiene todos los componentes y herramientas que se enumeran en las páginas.

Advertencia: Coloque todas las piezas sobre una superficie plana. Coloque una manta suave o algo similar debajo para protegerlas de rayones o manchas. Evite arrastrar o deslizar los componentes por el piso.

Advertencia: Verifique regularmente todos los accesorios y fijaciones para asegurarse de que estén seguros y evitar accidentes. Si falta alguna pieza, está rota, dañada o desgastada, deje de usar el producto hasta que se hayan realizado las reparaciones con piezas autorizadas de fábrica.

Advertencia: No permita que los niños se suban a los muebles, ya que esto puede provocar que se vuelquen y lesiones personales graves. Monte los muebles fuera del alcance de los niños.

Advertencia: No coloque los muebles cerca de fuentes de fuego u objetos de alta temperatura para evitar el riesgo de incendio.

Advertencia: Limpie los muebles con un paño húmedo o alcohol, evite usar agentes de limpieza que contengan químicos corrosivos.

Advertencia: Este producto está equipado con un dispositivo antivuelco. Asegúrese de instalar este dispositivo para evitar lesiones innecesarias causadas por vuelcos.

EN

Dear customer,
Thank you for purchasing this product. So that your appliance serves you well, please read all the instructions in this user's manual. If you have any questions, please contact our customer care center.

FR

Cher client,
Nous vous remercions d'avoir acheté ce produit. Afin que vous puissiez profiter pleinement de votre appareil, veuillez lire toutes les instructions de ce manuel d'utilisation. Si vous avez la moindre question, veuillez contacter notre centre d'assistance à la clientèle.

DE

Sehr geehrter Kunde,
Vielen Dank, dass Sie dieses Produkt erworben haben. Damit Ihr Gerät Ihnen gute Dienste leistet, lesen Sie bitte alle Hinweise in diesem Benutzerhandbuch. Wenn Sie Fragen haben, wenden Sie sich bitte an unser Kundendienstzentrum.

ES

Queridos clientes,
Gracias por comprar este producto. Para que su electrodoméstico le sirva mejor, lea todas las instrucciones de este manual del usuario. Si tiene alguna pregunta, comuníquese con nuestro Centro de Atención al Cliente.

IT

Caro Cliente,
Grazie per aver acquistato questo prodotto. Per servirti meglio con questo apparecchio ti prego di leggere tutte le istruzioni in presente manuale utente. In caso di dubbio, si prega di contattare il nostro centro assistenza clienti.

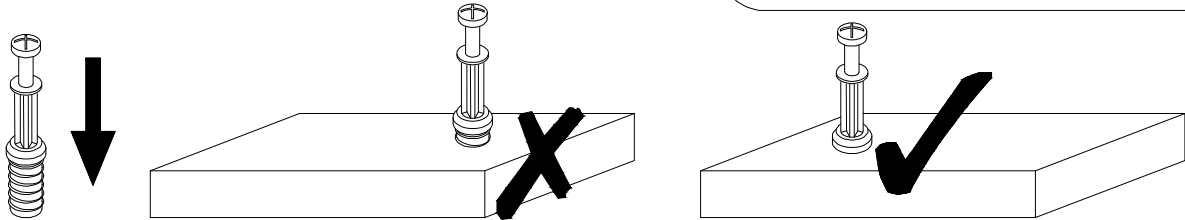

EN QUICKFIT: Tighten quickfit until shoulder is flush with panel. Do not overtighten or undertighten.

FR RACCORD RAPIDE: Faites serrer le raccord rapide jusqu'à ce que l'épaulement soit parfaitement encastré dans le panneau. Il ne faut ni trop serrer ni insuffisamment serrer.

ES QUICKFIT: Apriete quickfit hasta que el hombro se descargue con el panel. NO lo sobreapriete ni lo apriete poco.

DE QUICKFIT: Ziehen Sie den Quickfit fest, bis die Schulter mit der Platte bundig ist.

Bitte nicht zu fest oder zu schwach anziehen.

IT_MONTAGGIO RAPIDO: Stringere il montaggio rapido fino a quando la spalla è a filo con il pannello, non stringere troppo o troppo poco.

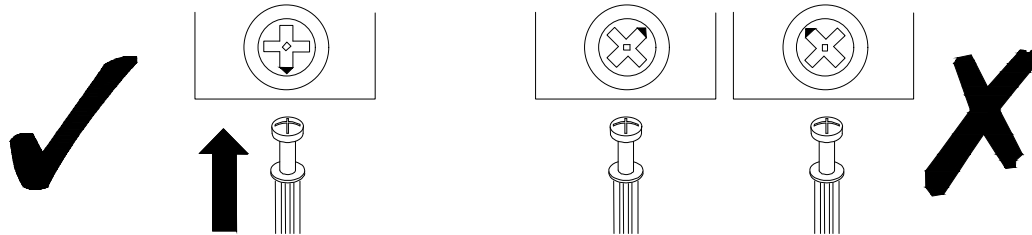

EN CAM LOCK: When fitting cam lock, ensure starting position is correct before you insert connecting quickfit.

FR SERRURE BATTEUSE: Avant d'insérer la serrure batteuse, veillez à la bonne orientation avant d'insérer le raccord rapide.

ES CIERRE DE LA CAMARA: Cuando instale el cierre de la cámara, asegúrese de que la posición de inicio es correcta antes de que inserte el quickfit conector.

DE_CAM-LOCK: Achten Sie bei der Montage des Cam-Locks auf die richtige Ausgangsposition, bevor Sie den Quickfit einsetzen.

IT_BLOCCAGGIO A CAMMA: Quando si monta il bloccaggio a camma, assicurarsi che la posizione iniziale sia corretta prima di inserire il montaggio rapido di collegamento.

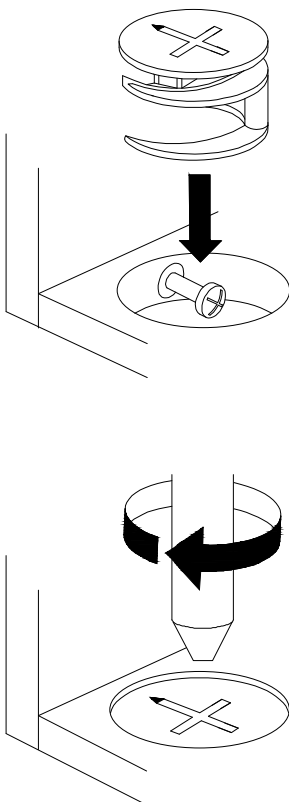

EN Quickfit head should be in the centre of the cam lock when the two panels are joined.

Cam lock should be inserted before quickfit.

FR_Lorsque les deux panneaux sont assemblés, la tête du raccord rapide doit reposer au centre de la serrure batteuse.

Il faut insérer la serrure batteuse avant le raccord rapide.

ES_El cabezal del quickfit debe estar en el centro del cierre de la cámara cuando se unan los dos paneles.

Se debe insertar el cierre de la cámara antes que el quickfit.

DE_Der Quickfit-Kopf sollte sich in der Mitte des Cam-Locks befinden, wenn die beiden Platten zusammengefügt sind.

Der Cam-Lock sollte vor dem Quickfit eingesetzt werden.

IT_La testa del montaggio rapido deve trovarsi al centro del bloccaggio a camma quando i due pannelli sono uniti.

Il Bloccaggio a Camma deve essere inserito prima del montaggio rapido.

Il Bloccaggio a Camma deve essere inserito prima del montaggio rapido.

Il Bloccaggio a Camma deve essere inserito prima del montaggio rapido.

EN Turn cam lock clockwise to tighten.

FR Faites tourner la serrure batteuse dans le sens des aiguilles d'une montre pour la resserrer.

ES Gire el cierre de la cámara en sentido horario para apretarlo.

DE Drehen Sie den Cam-Lock im Uhrzeigersinn, um ihn festzuziehen.

festzuziehen.

IT Ruotare il bloccaggio a camma in senso orario per stringere.

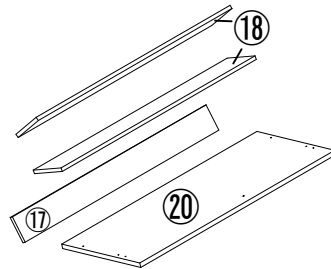
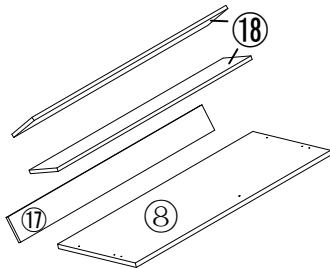
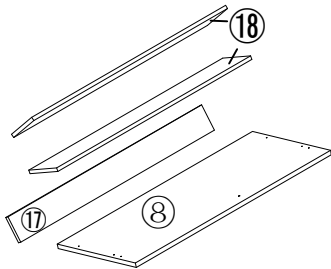
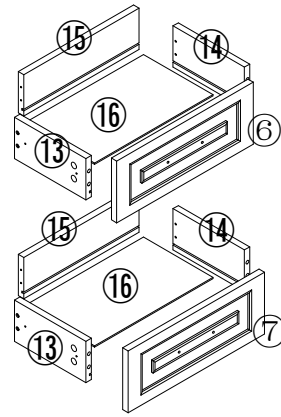
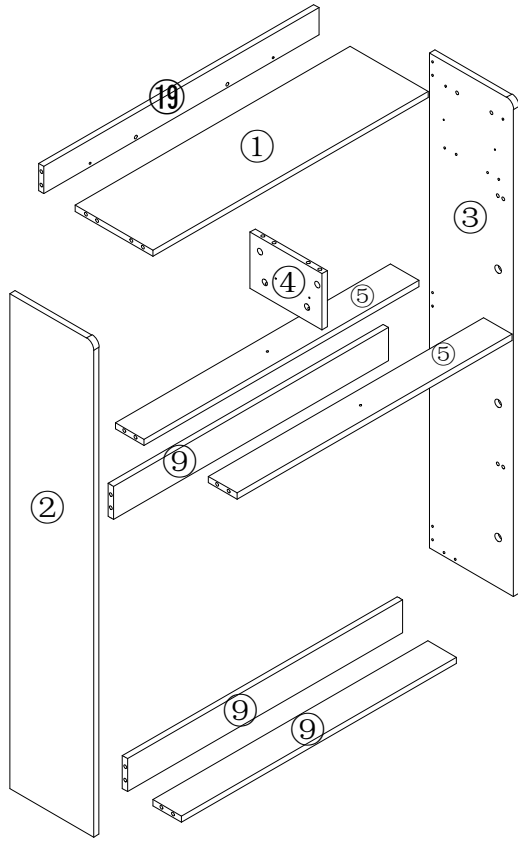

BOX-1

⑥

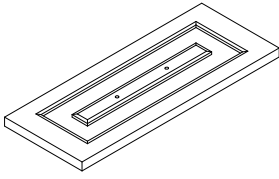

1

⑦

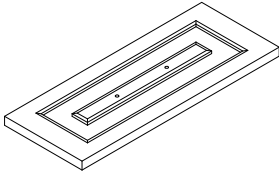

1

⑧

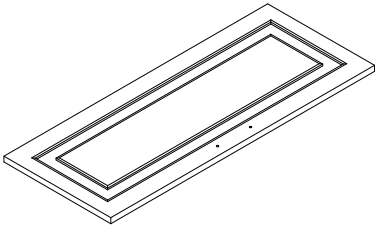

2

⑬

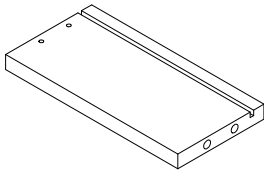

2

⑭

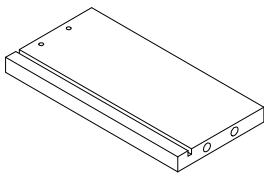

2

⑮

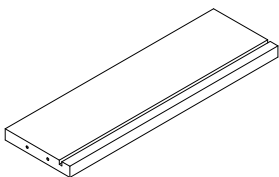

2

BOX-2

①

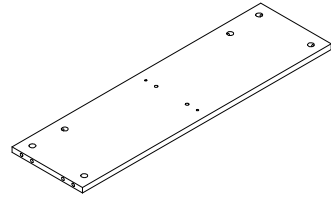

1

②

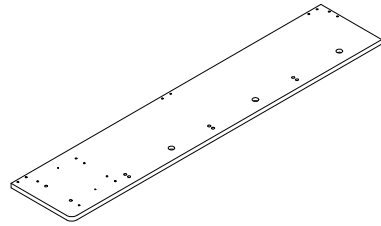

1

③

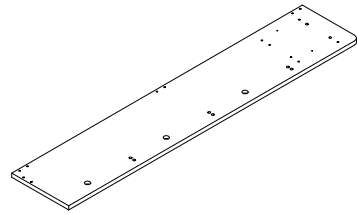

1

④

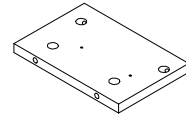

1

⑤

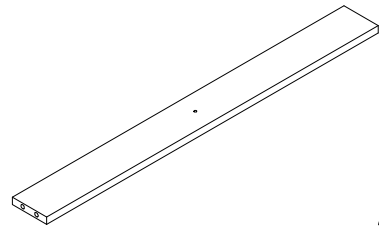

2

⑨

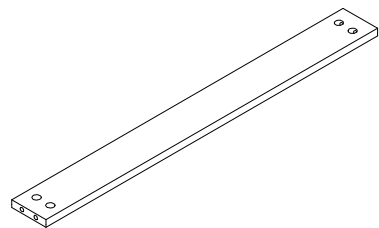

3

BOX-1

17

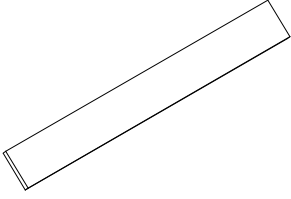

3

18

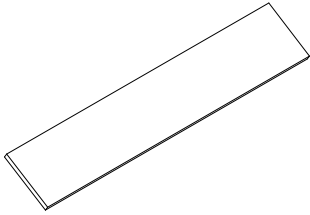

6

20

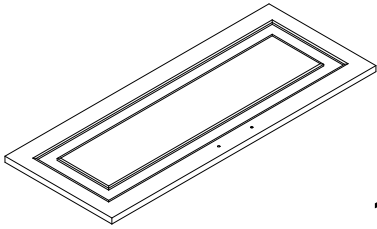

1

BOX-2

16

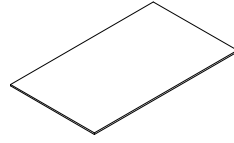

2

19

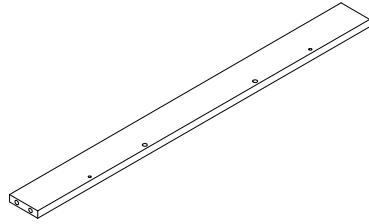





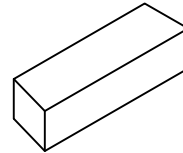



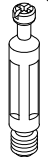

1

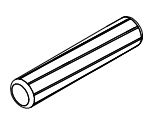
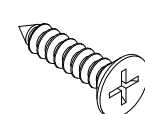
Hardware Box

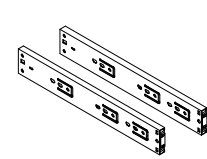
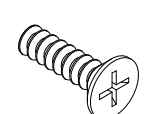

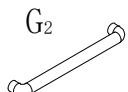
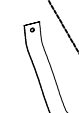
1

Hardware List

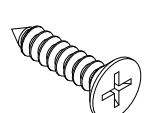
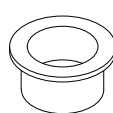
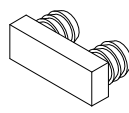
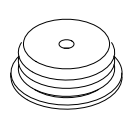
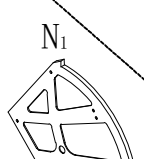
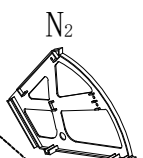

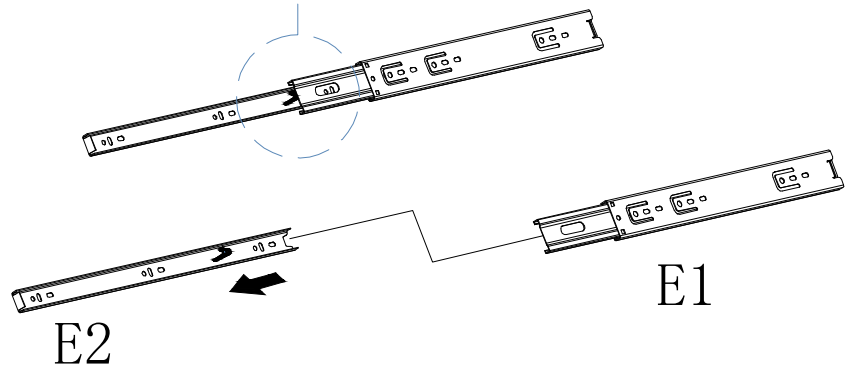
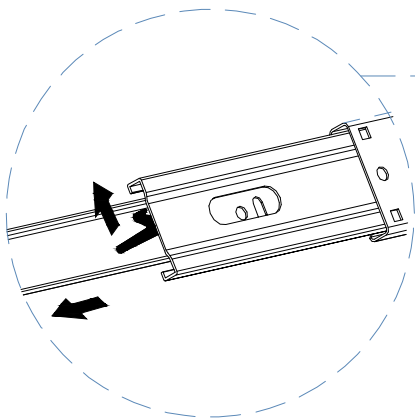
<p>A₁ Ø15*11.5 42PCS</p>  <p>A₂</p>  <p>Ø6*40 42PCS</p>	<p>B</p>  <p>Ø8*40 8PCS</p>	<p>C</p>  <p>M3.5*14 34PCS</p>	<p>D</p>  <p>M3.5*35 8PCS</p>
<p>E</p>  <p>L=200mm 4PCS</p>	<p>F</p>  <p>M4*12 6PCS</p>	<p>G₁</p>  <p>G₂</p>  <p>5PCS</p> <p>10PCS</p>	<p>H₁</p>  <p>2PCS</p> <p>H₂</p>  <p>2PCS</p> <p>H₃</p>  <p>2PCS</p> <p>H₄</p>  <p>2PCS</p>
<p>I</p>  <p>M3.5*16 18PCS</p>	<p>O</p>  <p>6PCS</p>	<p>L</p>  <p>6PCS</p>	<p>M</p>  <p>6PCS</p>
<p>N₁</p>  <p>3PCS</p> <p>N₂</p>  <p>3PCS</p>	<p>By using this device, the slide rail is divided into two parts A través de este dispositivo, el deslizamiento se divide en dos partes Divisez la glissière en deux parties avec cet appareil Utilizzando questo dispositivo, la guida scorrevole è divisa in due parti Mit diesem Gerät wird die Gleitschiene in zwei Teile unterteilt</p>		

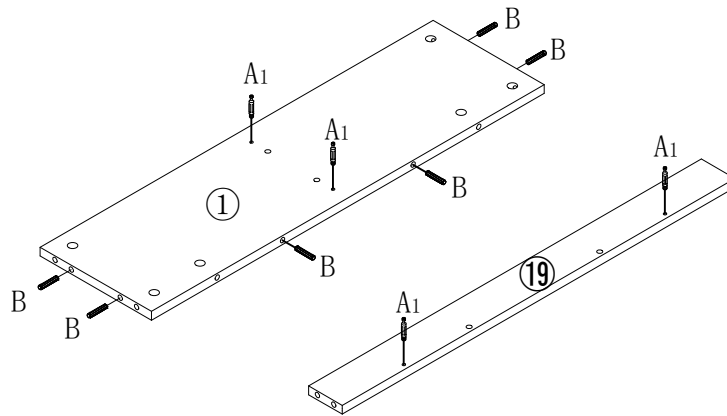

Schritt 1

Step 1



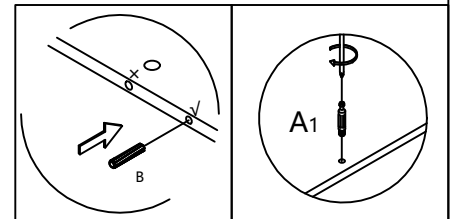

	A ₁ x4pcs
	Bx6pcs



Schritt 2

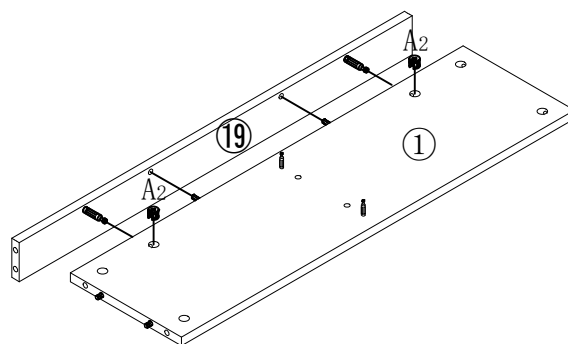



Step 2

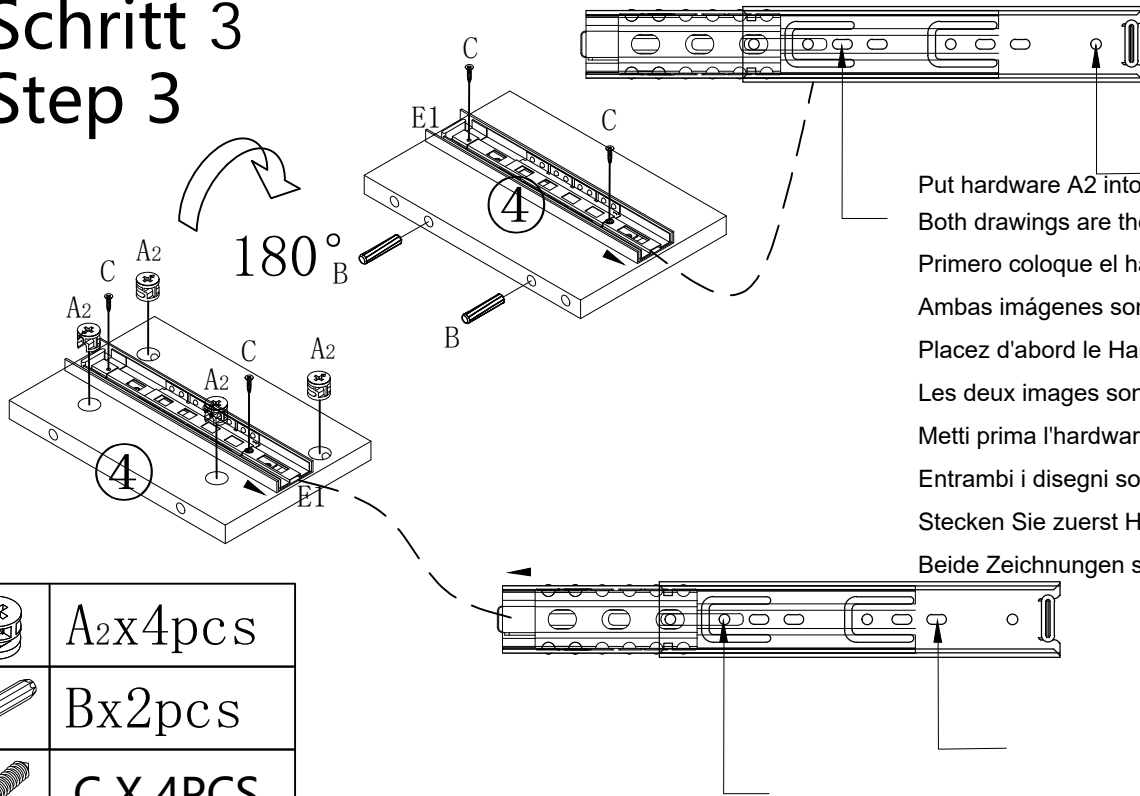

	A ₂ x2pcs
--	----------------------

Schritt 3 Step 3



	A2x4pcs
	Bx2pcs
	C X 4PCS
	E1 X 2PCS

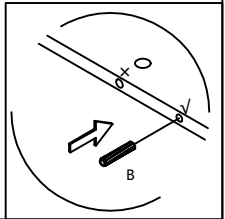

Schritt 4 Step 4

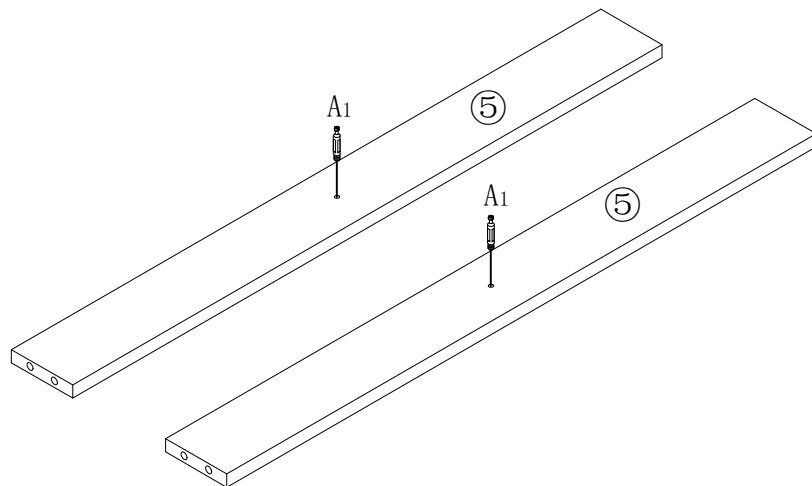

	A1x2pcs
--	---------

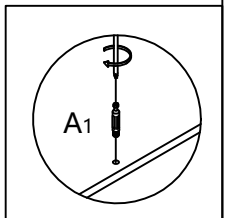

Schritt 5 Step 5

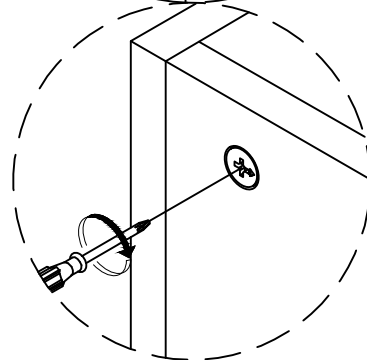
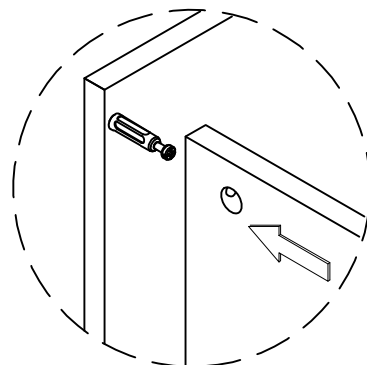
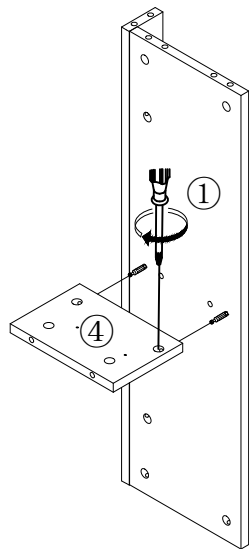

Schritt 6 Step 6

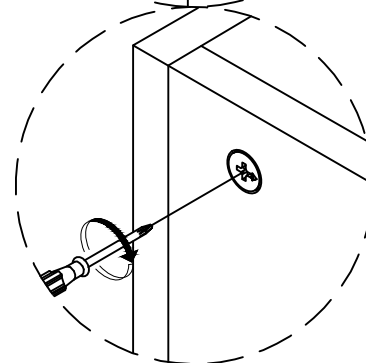
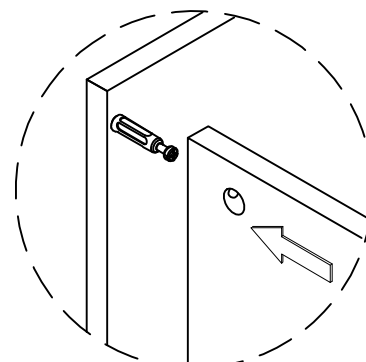
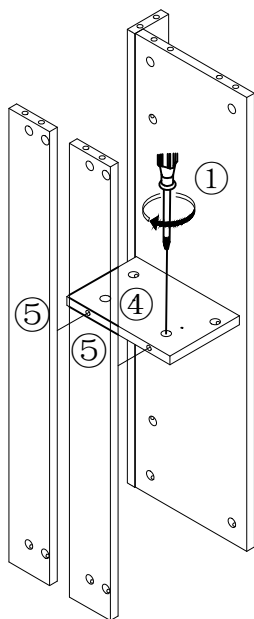

Schritt 7 Step 7

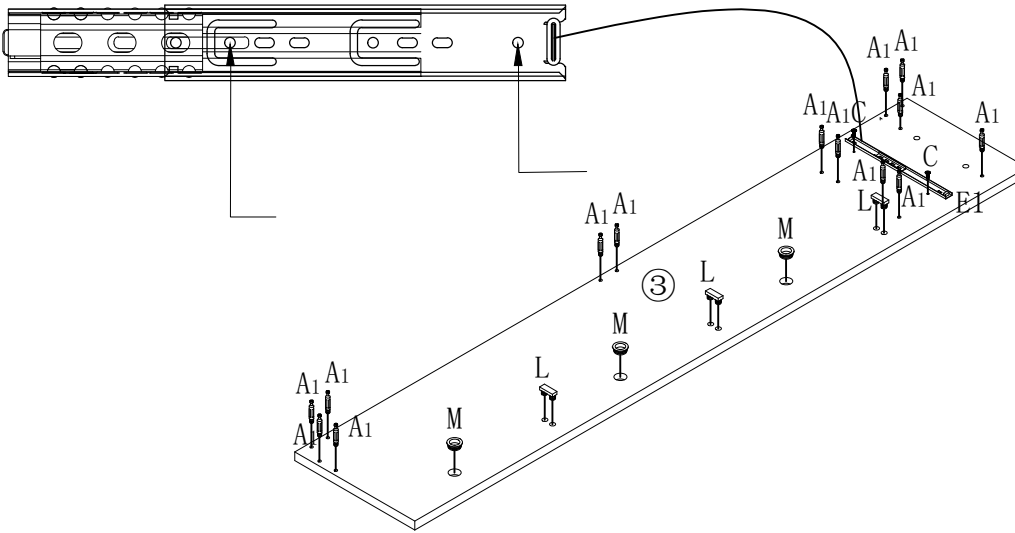

	A ₁ x14pcs		Lx3pcs
	Cx2pcs		Mx3pcs
	E ₁ x1pcs		

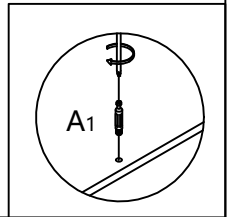



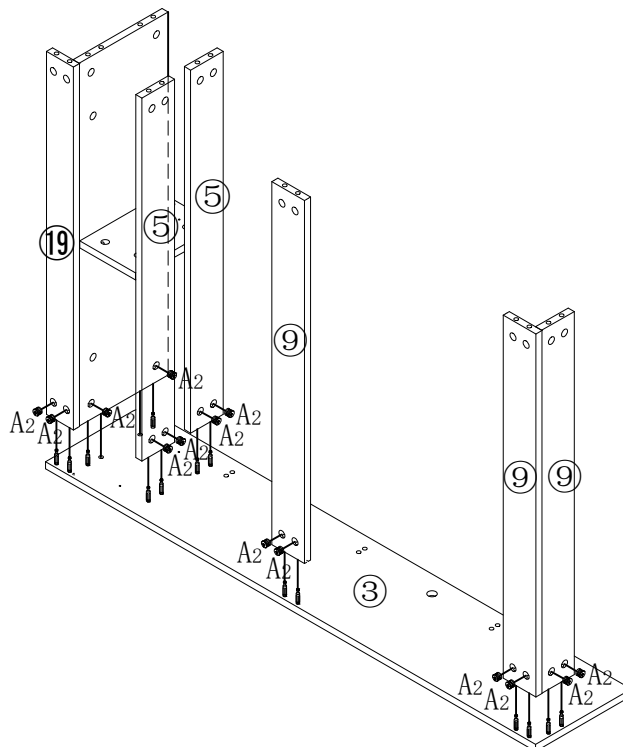

Schritt 8 Step 8



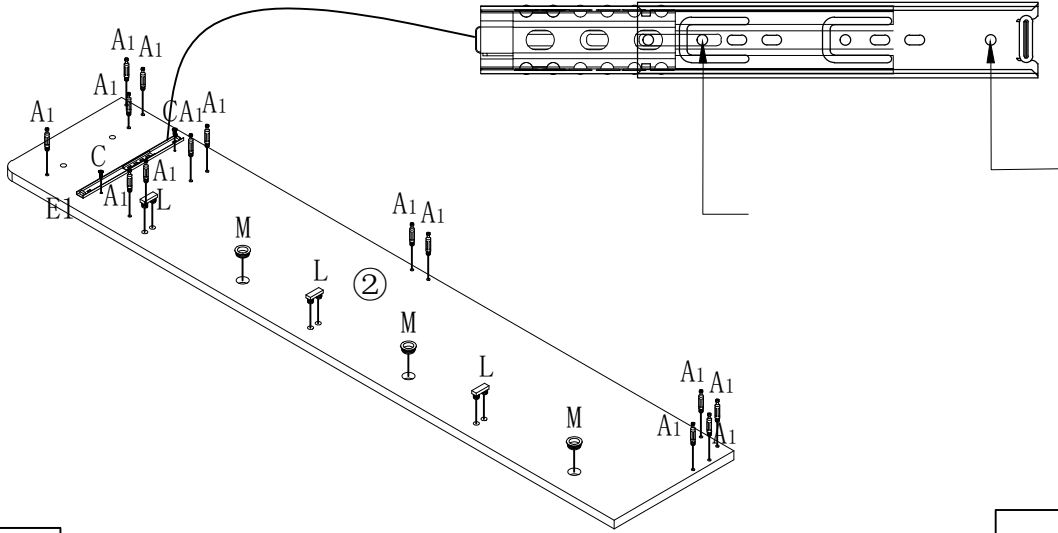

	A ₂ x14pcs
--	-----------------------

Schritt 9 Step 9



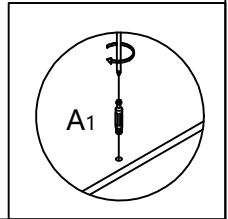

	A ₁ x14pcs
	Cx2pcs
	E ₁ x1pcs

	Lx3pcs
	Mx3pcs

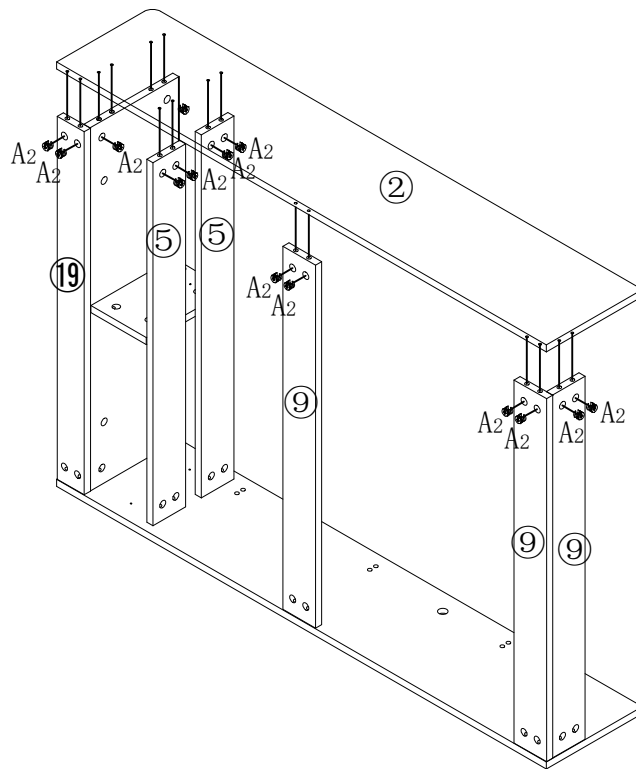

Schritt 10 Step 10





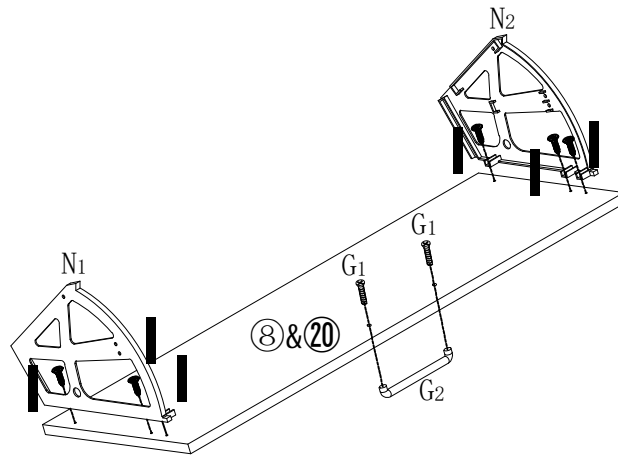

	A ₂ x14pcs
--	-----------------------

Schritt 11

Step 11



	Ix18PCS
	N1x3PCS
	N2x3PCS
	G1x6PCS
	G2x3PCS

Schritt 12

Step 12

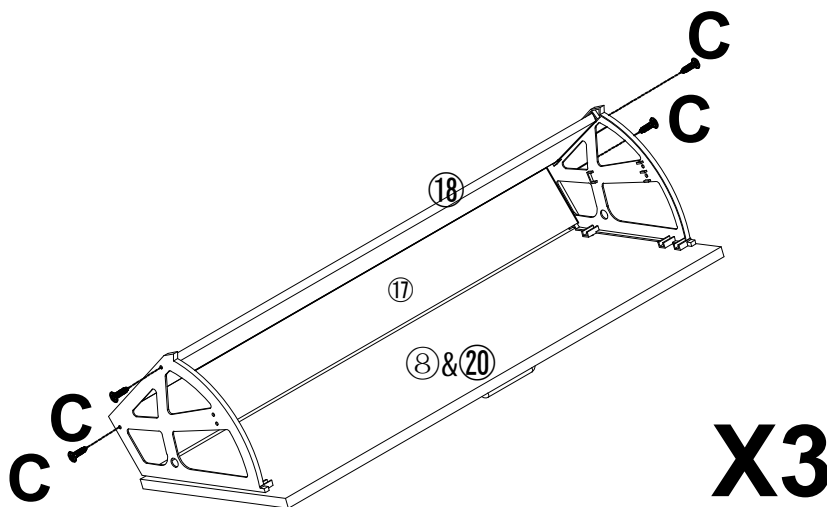



	Cx12pcs
--	---------

Schritt 13

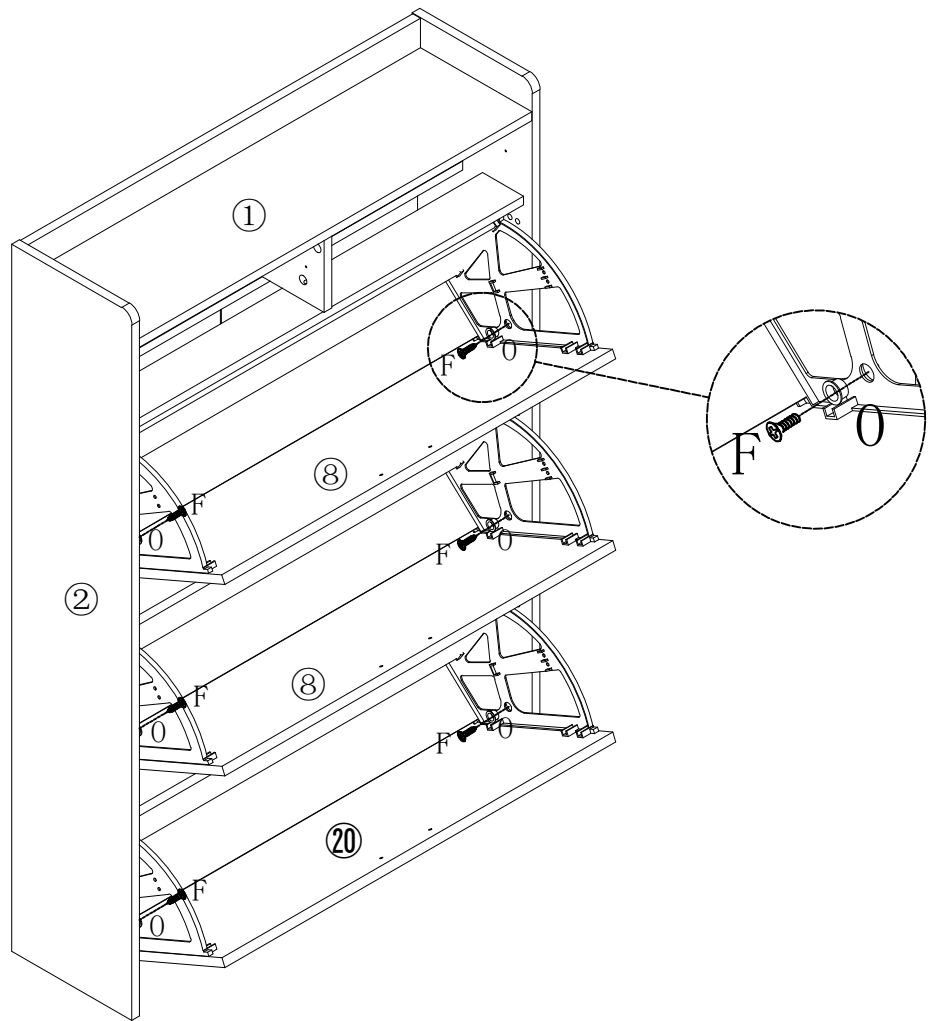
Step 13



	Ox6PCS
	Fx6PCS

Schritt 14

Step 14

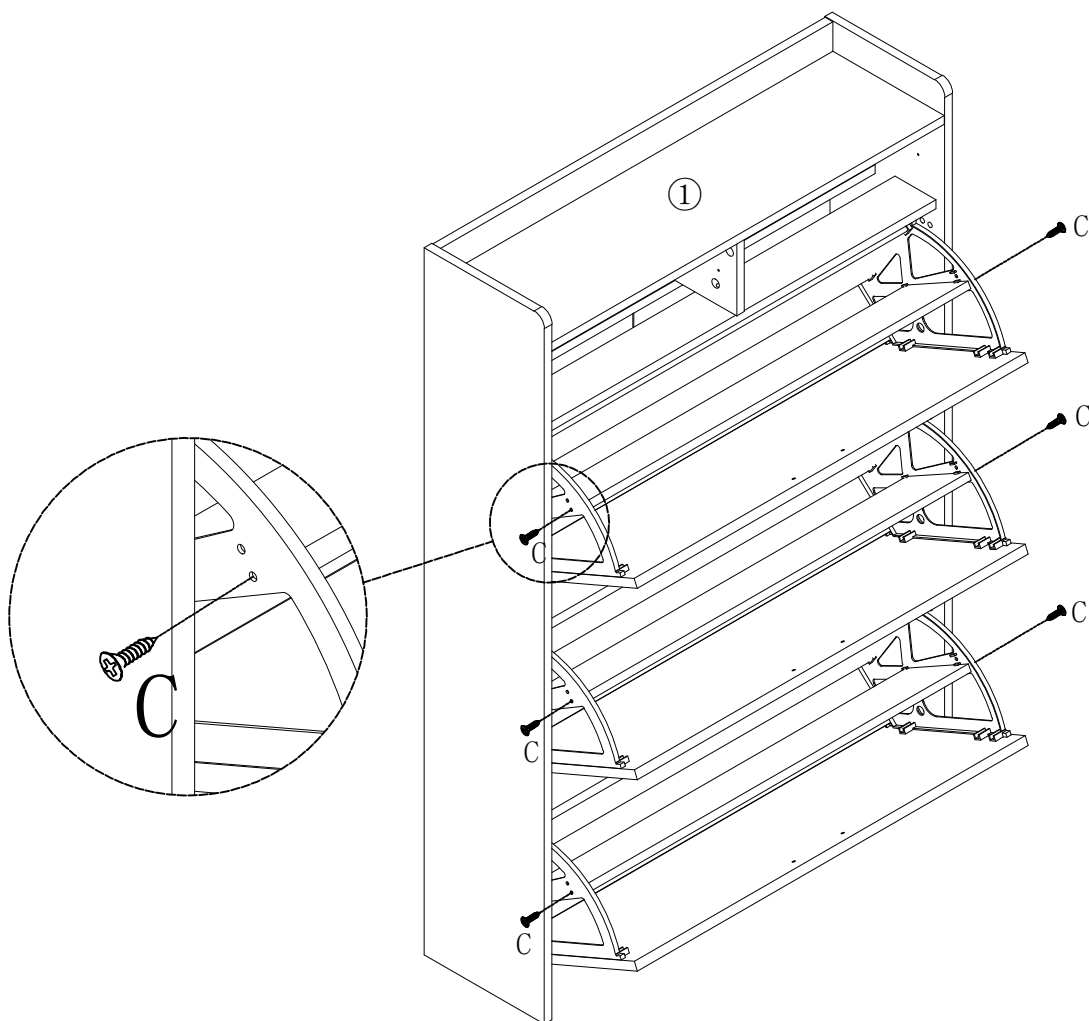

Cx6pcs

Schritt 15

Step 15

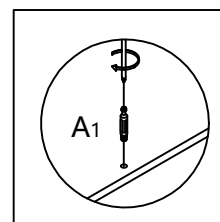
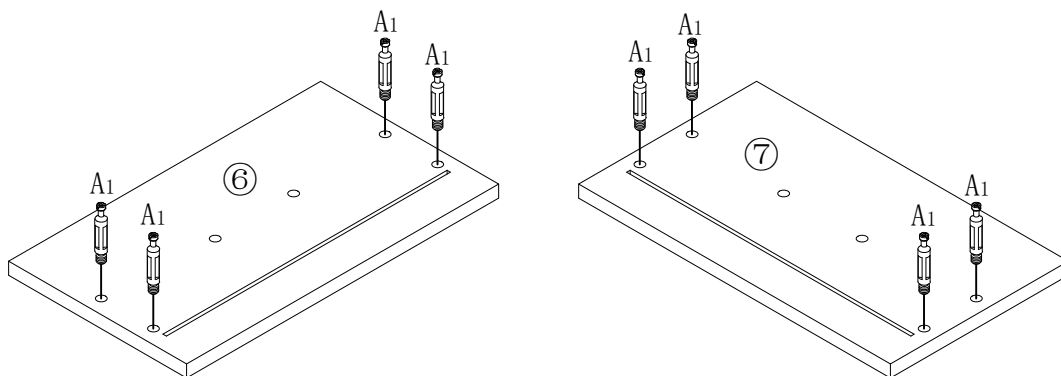

A₁x8pcs

Schritt 16

Step 16

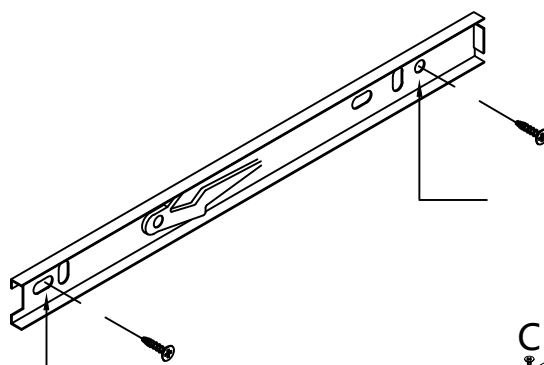

Put hardware A2 into the hole first
 Primero coloque el hardware A2 en el agujero
 Metti prima l'hardware A2 nel foro
 Placez d'abord le Hardware A2 dans le trou
 Stecken Sie zuerst Hardware A2 in das Loch

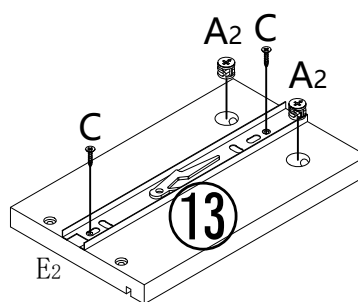

X2

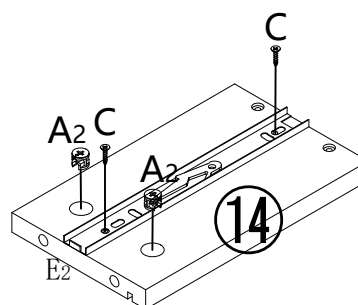

Cx8pcs

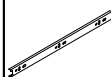

E₂x4pcs



A₂x8pcs

Schritt 17

Step 17

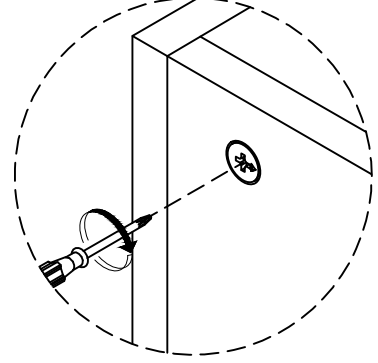
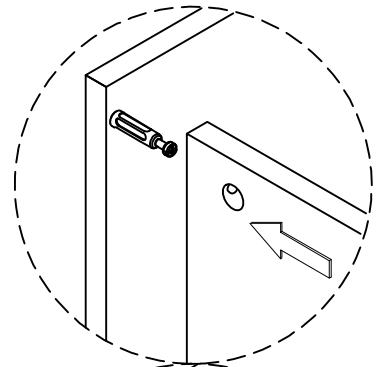
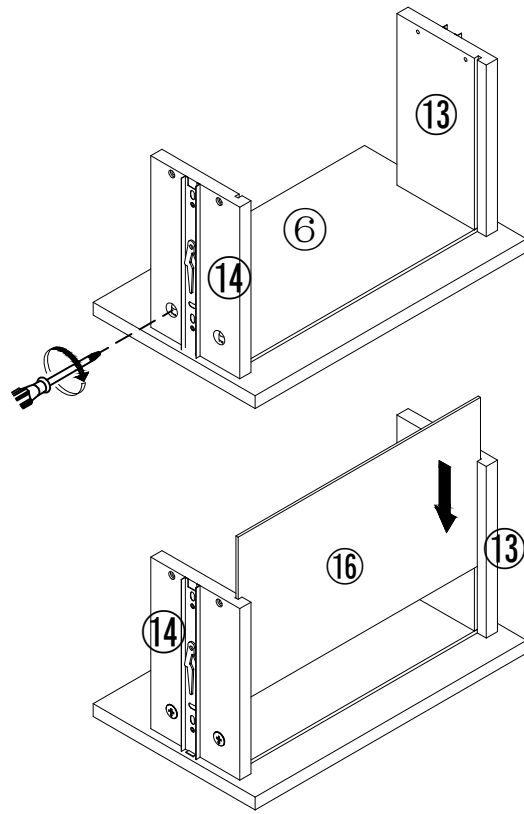

Schritt 18

Step 18

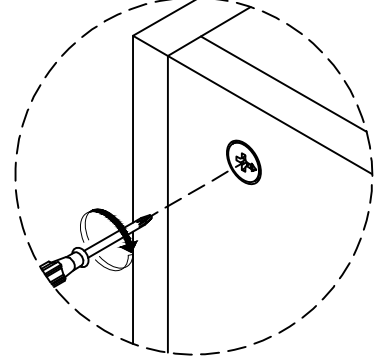
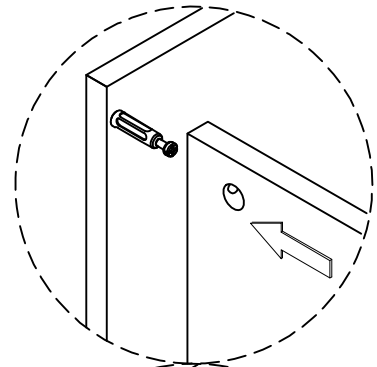
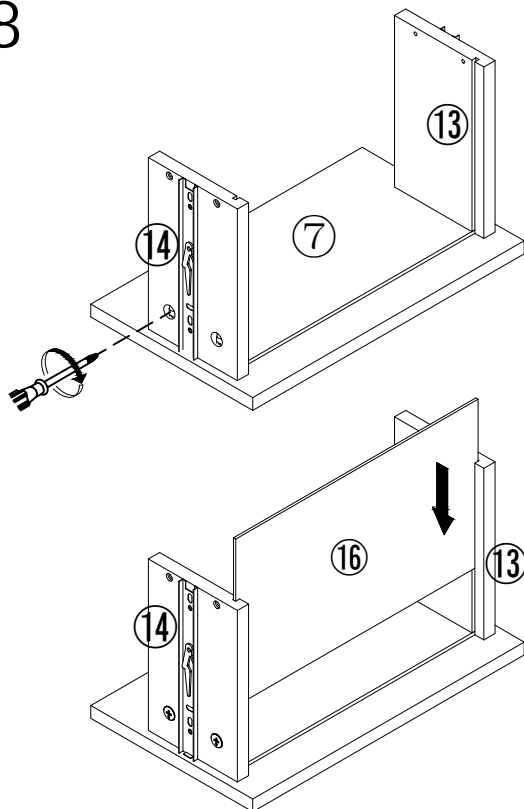

Schritt 19

Step 19

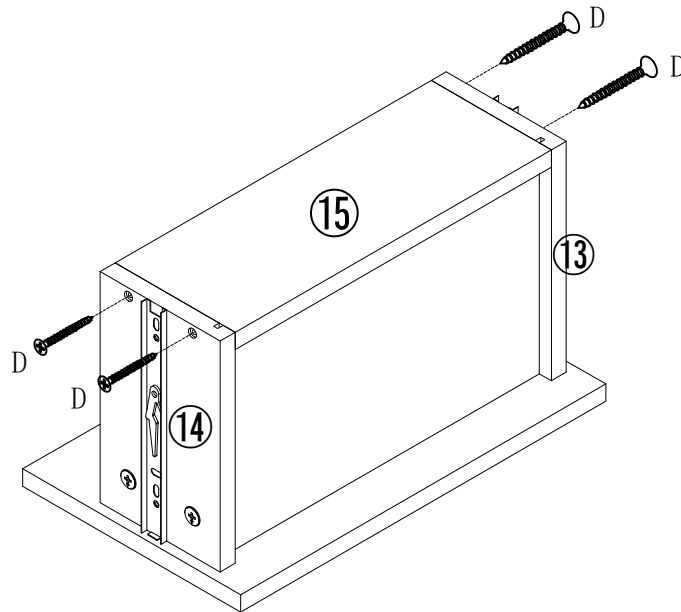

Dx4pcs

Schritt 20

Step 20

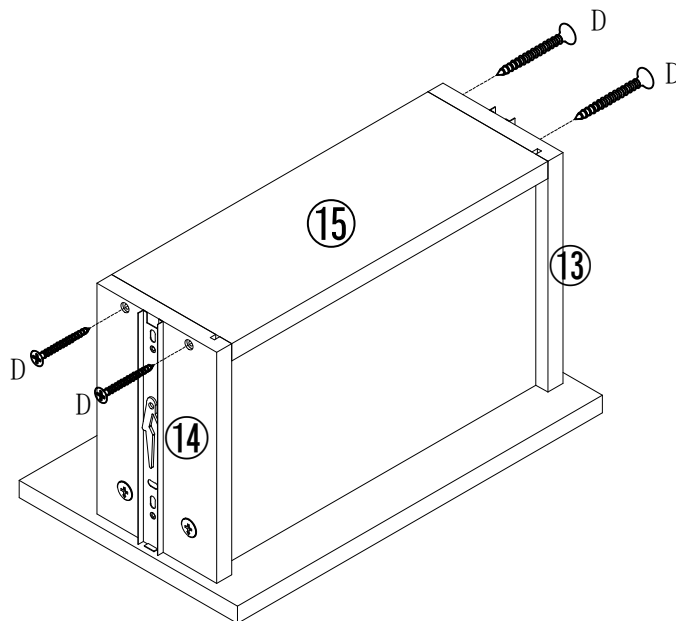

Dx4pcs

Schritt 21

Step 21

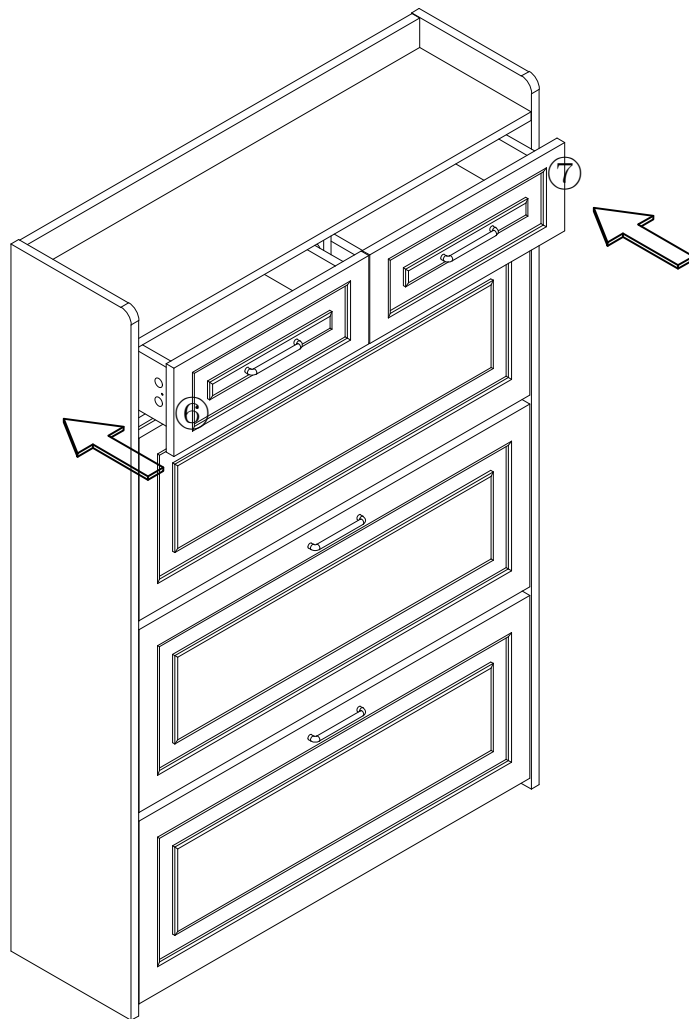
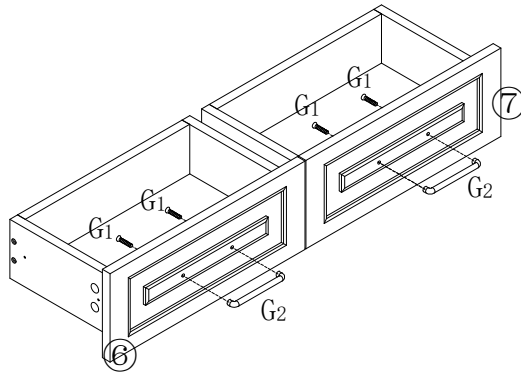

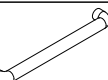

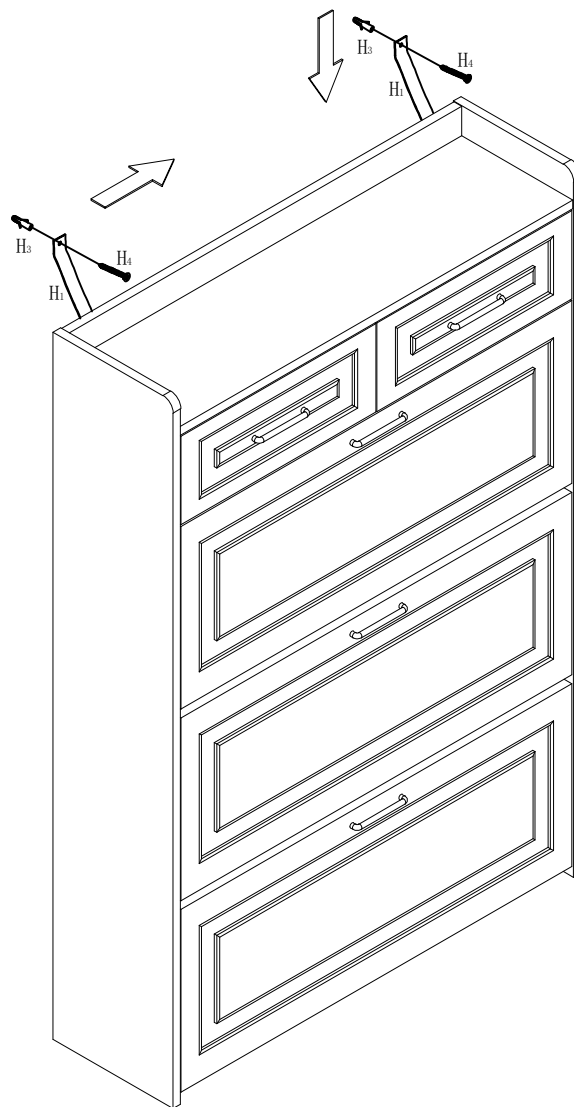

	G1x4PCS
	G2x2PCS

Schritt 22

Step 22



	H ₁ x2pcs
	H ₂ x2pcs
	H ₃ x2pcs
	H ₄ x2pcs

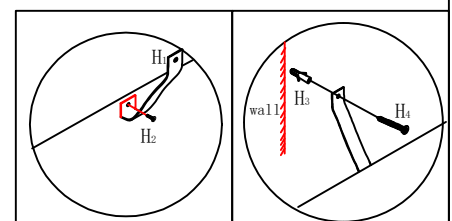

Schritt 23

Step 23

DE:ACHTUNG: Zur Sicherheit und Stabilität empfehlen wir Ihnen, die Kippsicherungszubehör an der Wand zu befestigen, um ein Umkippen, Verletzungen und Sachschäden zu verhindern.

UK:ATTENTION: For safety and stability, we suggest you have to secure the anti tip accessories to the wall to prevent tipping, injury, and property damage.

FR:ATTENTION : Pour la sécurité et la stabilité, nous vous recommandons de fixer les accessoires anti-basculement au mur afin d'éviter tout renversement, blessure et dommage matériel.

IT: ATTENZIONE: Per garantire sicurezza e stabilità, ti consigliamo di fissare gli accessori di sicurezza contro il ribaltamento alla parete, per prevenire ribaltamenti, lesioni e danni materiali.

ES:ATENCIÓN: Para garantizar seguridad y estabilidad, le recomendamos que fije los accesorios de seguridad contra el vuelco a la pared para prevenir vuelcos, lesiones y daños materiales.

NL: LET OP: Voor veiligheid en stabiliteit raden wij aan om de anti-kantelaccessoires aan de muur te bevestigen om kantelen, letsel en schade aan eigendommen te voorkomen.

SE: OBS: För säkerhet och stabilitet rekommenderar vi att du fäster anti-tipp-tillbehören på väggen för att förhindra att de tippar, skador och egendomsskador.

PL: UWAGA: Dla bezpieczeństwa i stabilności zalecamy przymocowanie akcesoriów antyprzewrócenia do ściany, aby zapobiec przewróceniu, urazom i uszkodzeniu mienia.