

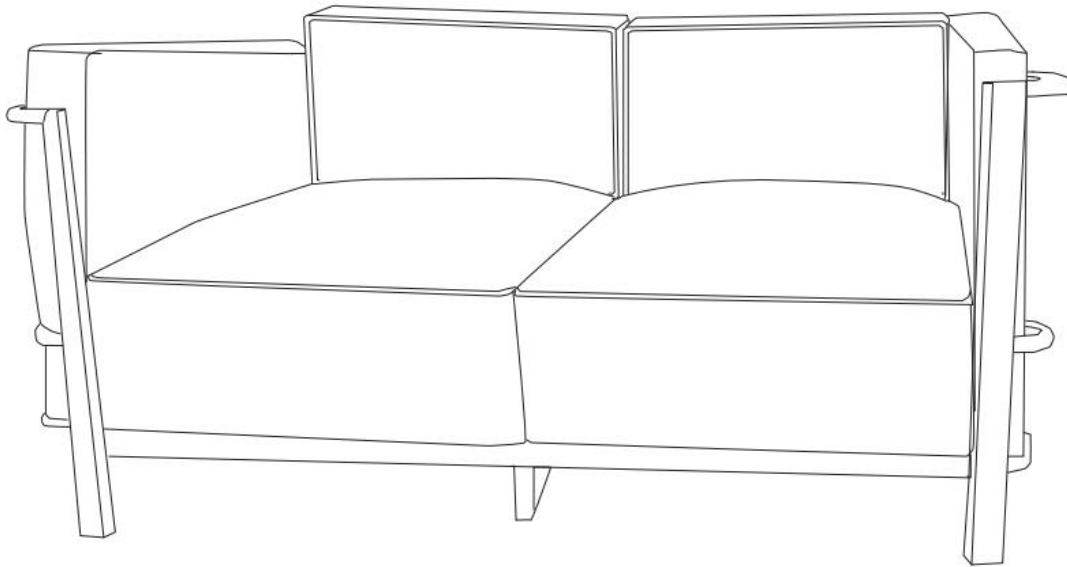

Assembly Instructions

Note: Please help to read my instruction before you ready to assemble.

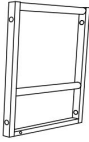

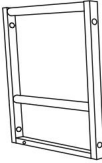
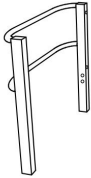
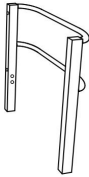
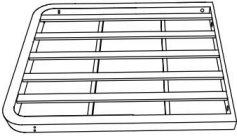
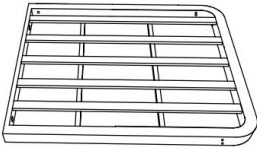

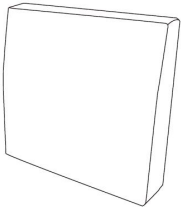
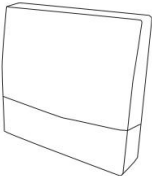

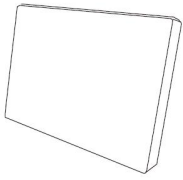
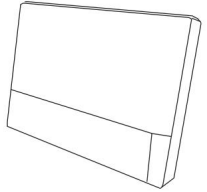
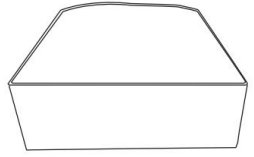
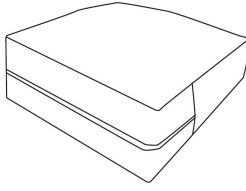
Love Seat



Part List			
Label	Picture	Description	QTY (PCS)
A		Left Back Frame	1
B		Right Back Frame	1
C		Left Armrest	1
D		Right Armrest	1
E		Left Seat Frame	1
F		Right Seat Frame	1
G		Connect Piece	1
H		Inner Back Cushion	2
H -Cover		Fabric Cover	2

I		Inner Armrest Cushion	2
I-Cover		Fabric Cover	2
J		Inner Seat Cushion	2
J-Cover		Fabric Cover	2

Hardware

①		Bolt (M6*35)	17
②		Bolt (M6*60)	3
③		Flat Washer	21
④		Spring Washer	19
⑤		Allen Wrench (S4)	1
⑥		Nut (M6)	3
⑦		Spanner	1

NOTICE:

- Please read the instruction from cover to cover in detail.Thanks.
- Installed by at least two adults
- To avoid damaging your furniture , Please don't assemble on flooring or carpet.
- Please assemble on a clean non-marring surface, example for packing foam.
- Saving all packaging until have finished.

Assembly Steps:

Step 01

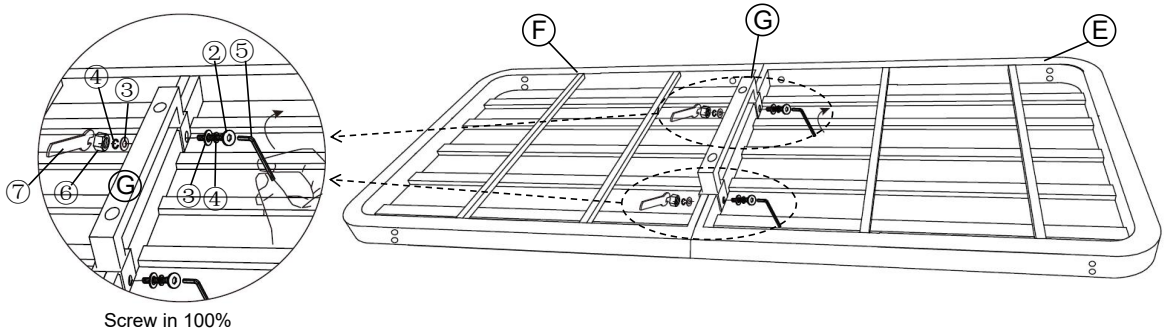

Step 02

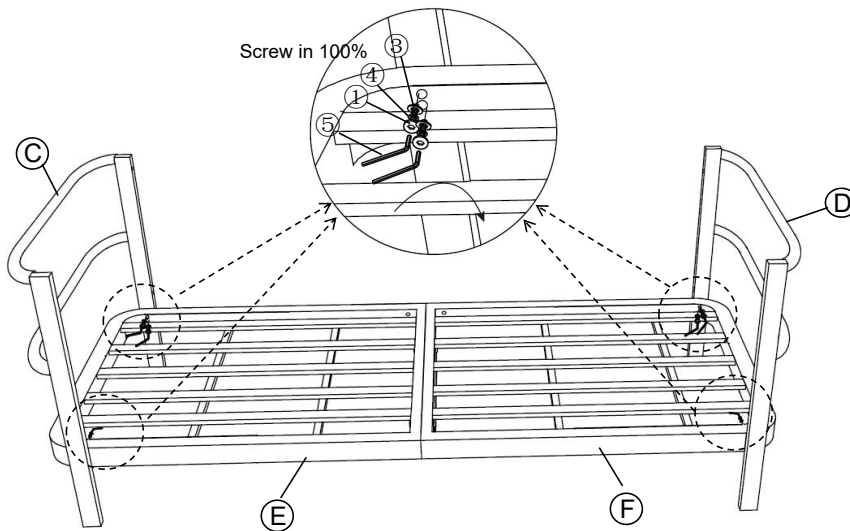

Step 03

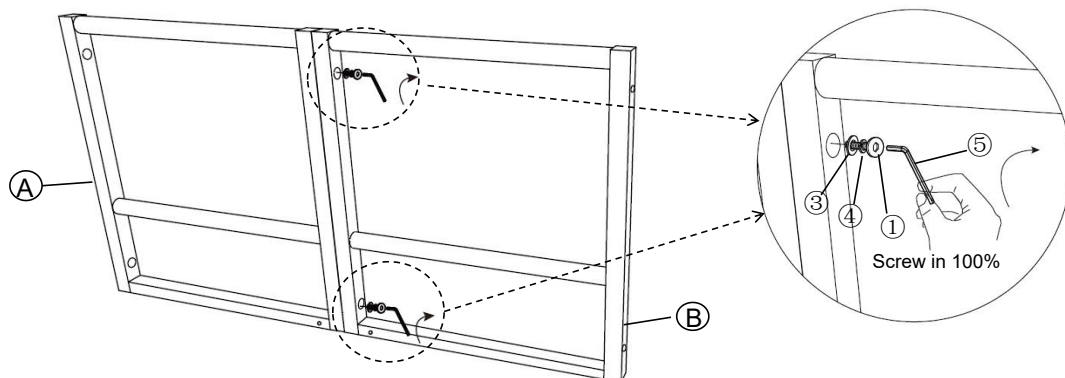

Step 04

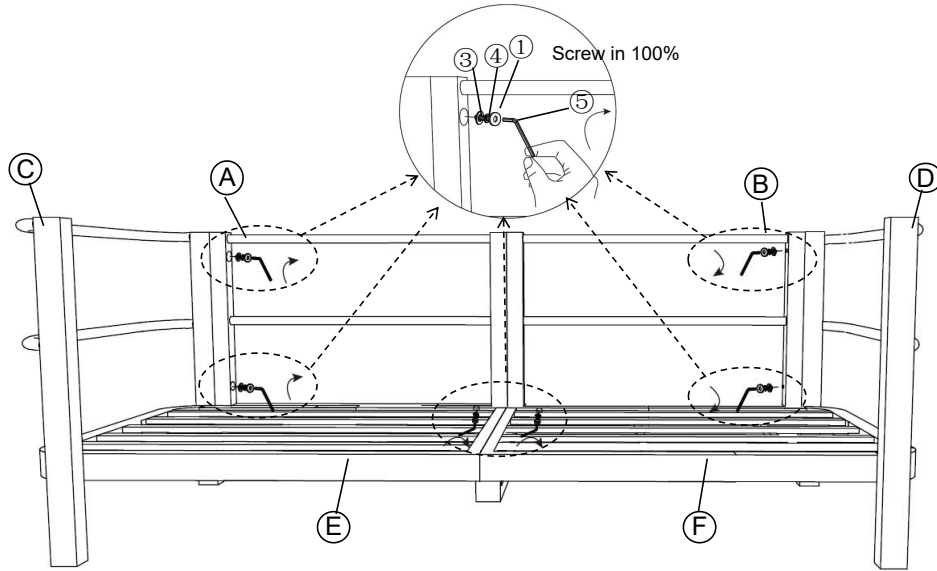

Step 05

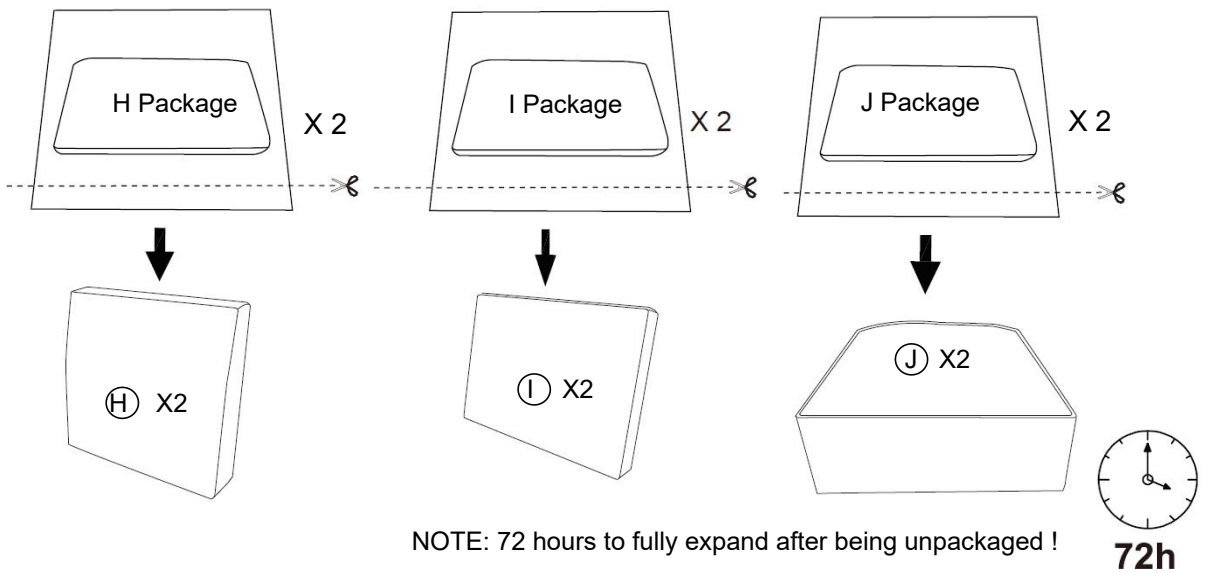

Step 06

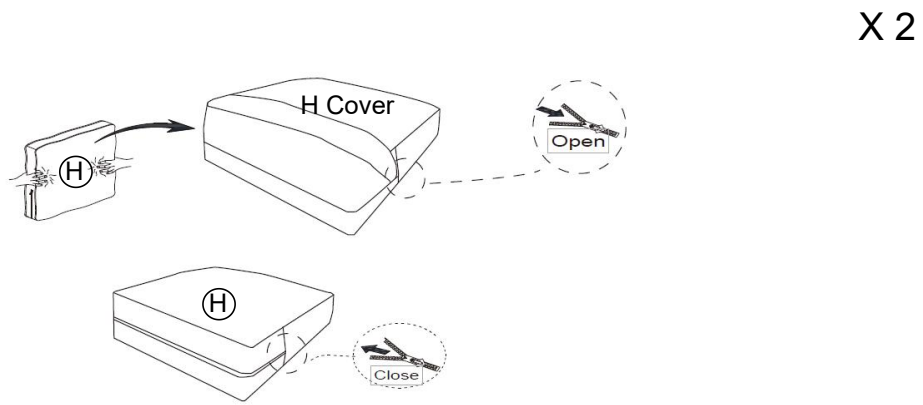

Step 07

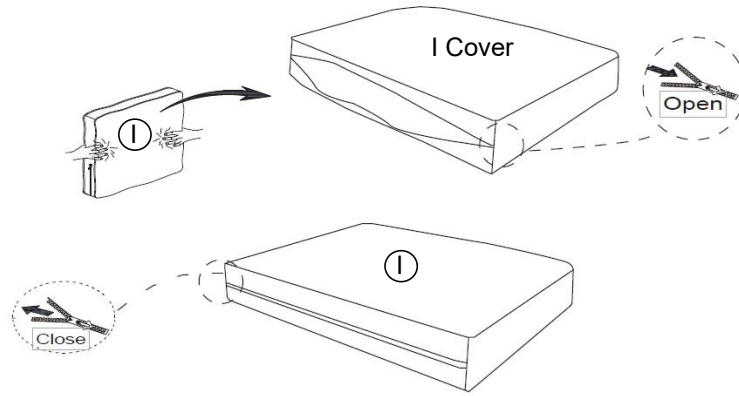

X 2

Step 08

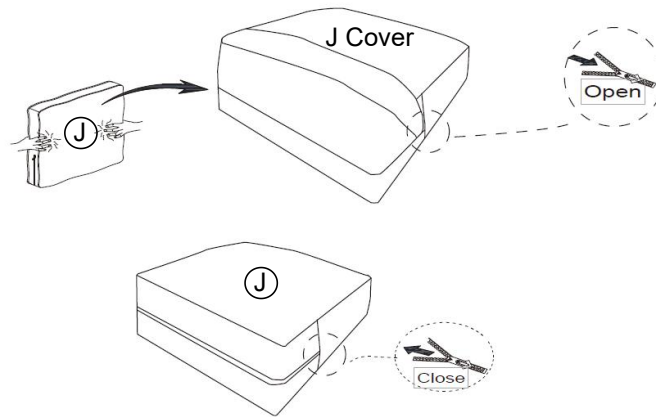

X 2

Step 09

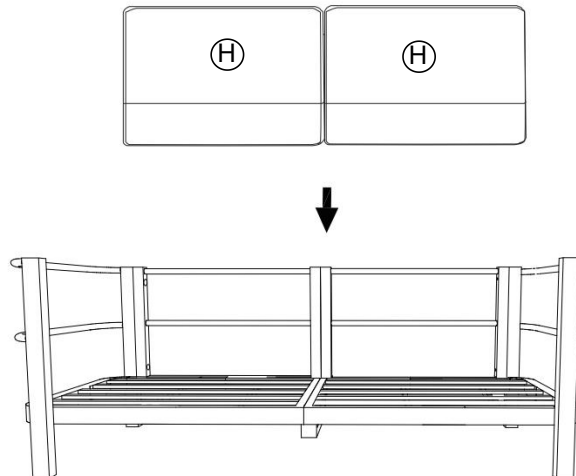

Step 10

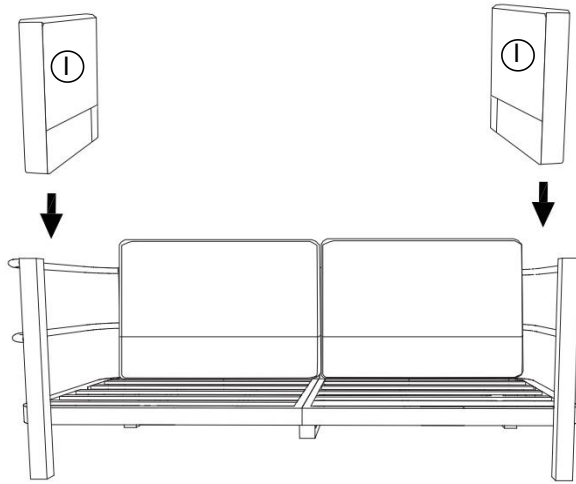

Step 11

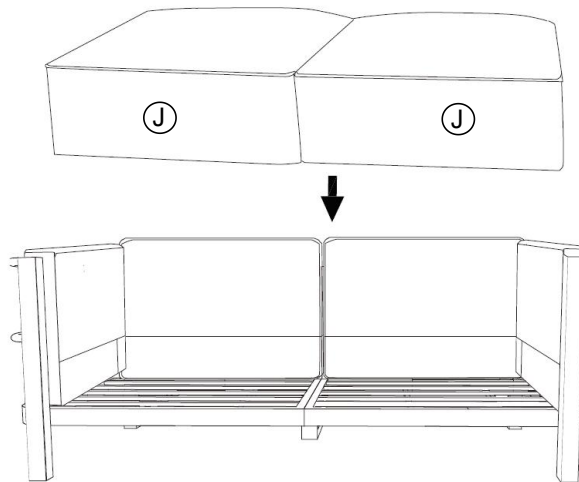

Step 12

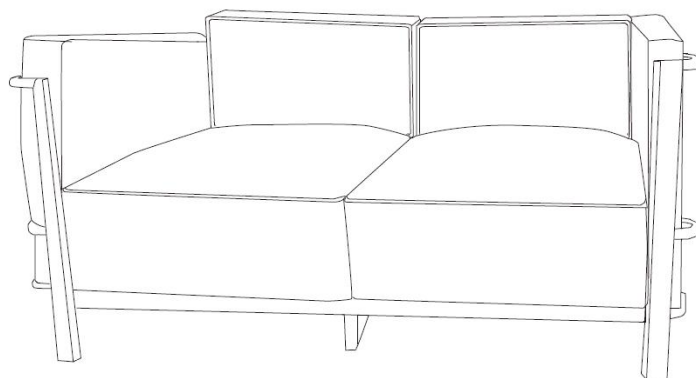

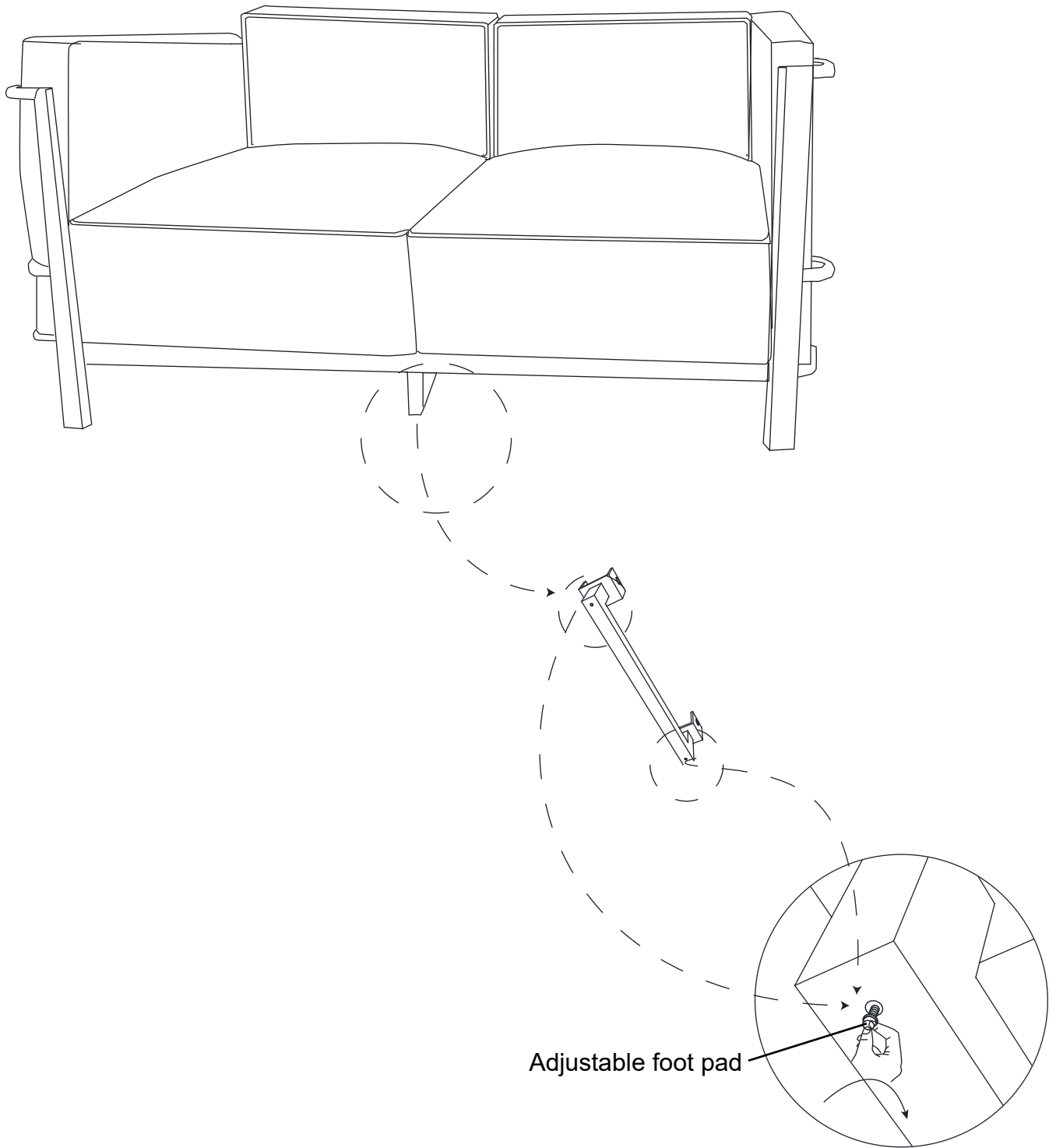

Please adjust the love seat with the adjustable foot pads when the floor is uneven.