

# Trampoline with Safety Enclosure

## USER MANUAL

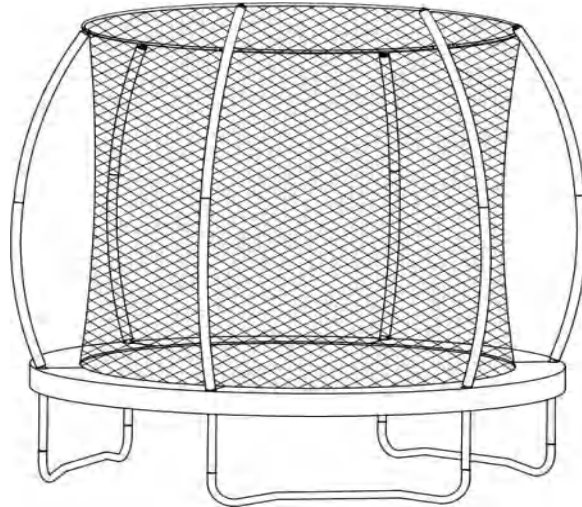

- 8'(244 cm) Trampoline
- 10'(305 cm) Trampoline
- 12'(366 cm) Trampoline
- 14'(427 cm) Trampoline
- 15'(457 cm) Trampoline
- 16'(487 cm) Trampoline

- 3 Legs*
- 4 Legs*
- 6 Legs*

Spring :  36  48  64  80  96  108

- Optional:
- Basketball hoop
  - Shoe bag
  - 2 step ladder
  - 3 step ladder

**READ THIS FIRST!!!**

**Thank you for purchasing our product**

**IN CASE OF MISSING OR BROKEN  
PARTS, PLEASE CONTACT PLACE OF  
PURCHASE FOR ASSISTANCE.**

**Warning: We are not liable for any injuries that may occur when using the trampoline.**

---

## GENERAL SAFETY

### ● INSTRUCTIONS



**BEFORE YOU BEGIN USING YOUR BIG TRAMPOLINE:** *Read and understand all this information provided to you in this manual.* As with all physical sports and activities there is the risk of participants receiving an injury. To ensure your future enjoyment and the prevention of injury, be sure to follow appropriate safety rules and tips.

- ALWAYS CONSULT A DOCTOR/PHYSICIAN BEFORE PERFORMING ANY KIND OF PHYSICAL ACTIVITY.
- ALWAYS CHECK YOUR BIG TRAMPOLINE BEFORE USE, PAYING SPECIFIC ATTENTION TO ALL THE BOLTS, JUMP MAT AND PADS POSITION. DON'T USE IF ANY PARTS ARE MISSING OR LOOK LIKE THEY SHOW WEAR AND TEAR.
- ALWAYS USES THE PROVIDED SAFETY ENCLOSURE WHEN USING THE TRAMPOLINE.
- ALWAYS ENSURE THAT THE TRAMPOLINE IS USED BY ONLY ONE PERSON AT A TIME.
- ALWAYS ENSURE THAT WHENEVER THE TRAMPOLINE IS USED BY ANYONE AT ANY SKILL LEVEL THAT DO SO UNDER SUPERVISION.
- Stop exercising immediately should you feel unwell or if you feel pain in your joints and muscles. Dizziness is a sign of fatigue and you should stop bouncing and lay down on the ground should you feel dizzy.
- When using this trampoline ensure appropriate clothing is worn, preferably sports wear and socks .NEVER WEAR SHOES ON THE MAT.
- Please be warned that trampoline is spring based and will allow the user to jump to a greater height than that on the ground, so please bear this in mind and ensure that you are comfortable bouncing at low heights first.
- Proper assembly, care and maintenance of product, safety tips, warnings, and proper techniques for jumping on your trampoline are included in this manual for your safety and an extended product life span. All users and supervisors should therefore familiarize themselves with these instructions. Anybody who chooses to use the trampoline must be aware of their own limitations with regards to performing skills on this trampoline.
- The safety enclosure is there to prevent the user falling off the trampoline, and is not to be jumped into unnecessarily.
- Trampoline should be assembled on grass or BSI approved safety matting.

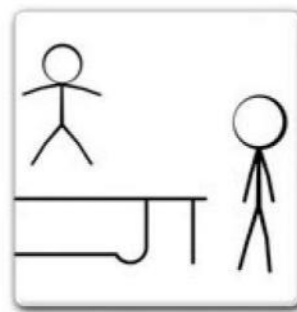

---

## INFORMATION ON THE

### ● USE OF TRAMPOLINE

**INITIALLY**, you should get accustomed to your trampoline and understand how much spring is in each bounce .The focus at this point should be body position and technique until each skill can be completed with ease and control.



- **BEFORE YOU TRY TO JUMP TOO HIGH** the technique for stopping should be learnt as this will help prevent injury should you feel you are jumping out of control.
- As the user lands on the bed knees should be bent so that they stop and absorb the spring in the mat.The position is shown in the image to the left. Arms are held out for increased level of balance.
- **This skill is used when the trampoline user wishes to stop bouncing on the trampoline due to fatigue, loss of control, etc.**



**SOMERSAULTS (FLIPS): DO NOT PERFORM** somersaults of any type (backwards or forwards)on this trampoline.If you make a mistake when trying to perform a somersault ,you could land on your head or neck .This will increase your chances of your neck or back being broken ,which could result in death or paralysis



**FOREIGN OBJECTS : DO NOT** use the trampoline if there are pets ,other people ,or any objects underneath the trampoline .This will increase the chances of an injury occurring ,DO NOT hold any foreign objects in your hand and DO NOT place any objects on the trampoline while in use. DO NOT place the trampoline under over-hanging objects like tree branches, wires, etc as these will increase your chances of being injured.



**POOR MAINTENANCE OF TRAMPOLINE:** A trampoline in poor condition will increase your risk of being injured. Please inspect the trampoline before each use for bent steel tubes, torn mat, loose or broken springs and overall stability of the trampoline.



**WEATHER CONDITIONS:** Please be aware of the weather conditions when using the trampoline. If the mat of the trampoline is wet, the user could slip and injure himself /herself .If it is too windy, the user could lose control.



**RESTRICTING ACCESS:** When the trampoline is not in use, always store the access ladder in a secure place so that unsupervised children can not play on the trampoline.

---

TIPS TO REDUCE THE  
● **RISK OF ACCIDENTS**

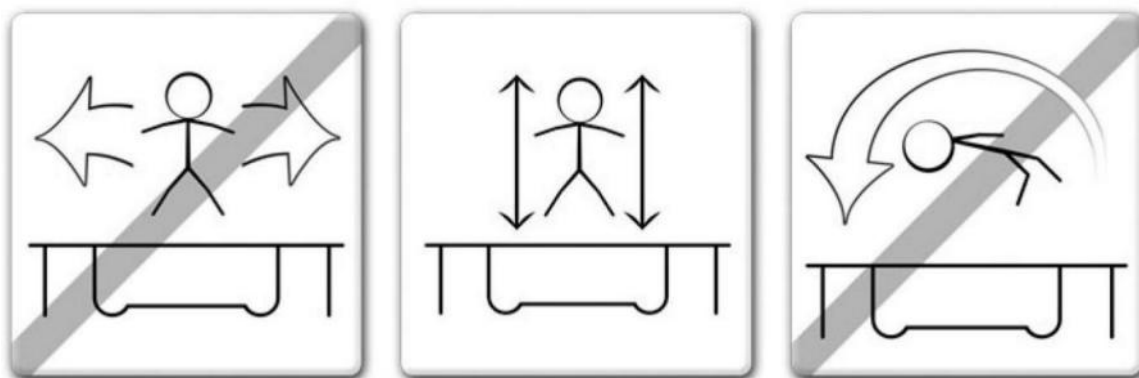

In order to reduce the risk of accident the "TRAMPOLINE USER" should:

- Always remain in control of their jumps and body position at all times.
- Not attempt to perform skills that are beyond their own level of competence.
- Read and understand the jump by taking off and landing in the middle of the trampoline.
- Always control their jump by taking off and landing in the middle of the trampoline.
- Always jump vertically and refrain from bouncing towards the springs in any direction.
- Always consult a professionally certified trampoline instructor before attempting anything beyond basic techniques.

In order to reduce the risk of accident the "SUPERVISOR" should:

- Fully understand and enforce all the safety rules and guidelines.
- Advise the trampoline user and provide knowledge in what they are doing right and wrong to ensure the safety of trampoline user.
- Be aware and advise the trampoline user of all the safety warnings.

**IMPORTANT: If the Trampoline can not be supervised there should be a method for securing it and preventing anyone from using the product until supervision is available.**

---

## TRAMPOLINE

### ● SAFETY INSTRUCTIONS

#### ADVISORY PRECAUTIONS WHILST USING THE TRAMPOLINE

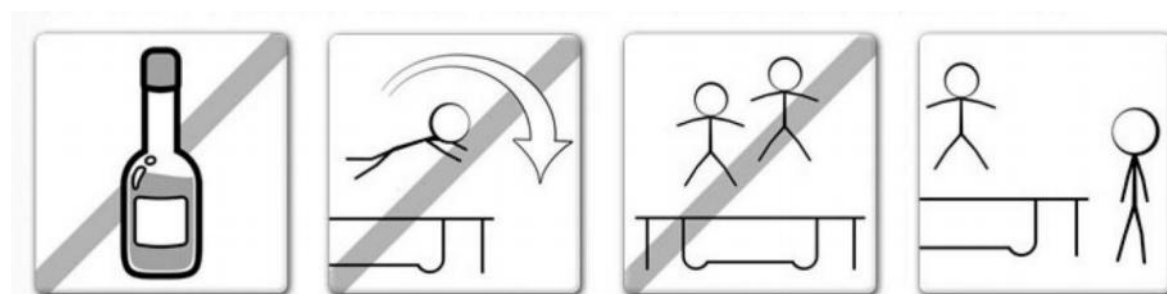

- Do not use trampoline if you have consumed alcohol or narcotic substances
- You should climb on and off the trampoline in a controlled and careful manner. Never jump onto or off the trampoline and never use the trampoline as a means to bounce onto or into another object.
- Always learn the basic bounce and master each type of bounce before trying more difficult types of bounces .Review the basic skills section to learn how to do the basics.
- To stop your bounce, flex your knees when you land on your feet.
- Always be in control when you are bouncing on the trampoline. A controlled jump is when you land at the same spot that you took off from. If at any time you feel out of control, stop bouncing immediately.
- Do not jump or bounce for prolonged periods of time or too high for a number of jumps. Keep your eyes on the mat to maintain control. If you do not, you could lose your balance.
- Never have more than 1 person on the trampoline at any one time.

#### ADVISORY PRECAUTIONS WHILST SUPERVISING TRAMPOLINE

**IMPORTANT:** Familiarity yourself with the basic jumps and safety rules .To prevent and reduce the risk of injuries, ensure that all safety rules are enforced and the new users learn the basic bounces before trying more advanced techniques .

- **ALL USERS need to be supervised, regardless of skill level or age.**
- Never use the trampoline when it is wet, damaged, dirty or worn out. The trampoline should be inspected before use.
- Keep all objects that could interfere during use away from the trampoline at all times. Be aware of what is overhead, underneath and around the trampoline.
- To prevent unsupervised and unauthorized use, the trampoline should be secured at all time.

---

## ACCIDENT

### ● CLASSIFICATION & IDENTIFICATION



#### **MOUNTING AND DISMOUNTING:**

Be very careful when getting on and off the trampoline. **DO NOT** mount the trampoline by grabbing the frame pad, stepping onto the springs or by jumping onto the mat of the trampoline from an object(eg. A deck, roof ,or ladder ).This is considered highly dangerous. **DO NOT** dismount by jumping off the trampoline and landing on the ground. If small children are playing on the trampoline, they may need help in mounting and dismounting.



#### **USE OF ALCOHOL OR DRUGS:**

**DO NOT** consume any alcohol or take any drugs (*this includes medication that could affect the users co-ordination*) when using this trampoline. This is considered highly dangerous since these foreign substances impair your judgement, reaction time and overall physical co-ordination.



#### **MULTIPLE USERS:**

If you have multiple users (more than one person on the trampoline at any one time), you increase the chance of being injured. Injuries can occur when you fly off the trampoline, lose control, collide with other jumper(s), or land on the springs .



#### **STRIKING THE SPRING FRAME:**

When playing on the trampoline, **STAY** in the centre of the trampoline mat. This will reduce the risk of being injured by landing on the spring frame. Always keep the frame pads covering the frame of the trampoline. **DO NOT** jump or step onto the frame pad directly since it is not intended to support the weight of a person.



#### **LOSS OF CONTROL:**

**DO NOT** try difficult maneuvers until you have mastered the basics. If you do not follow these guidelines, you increase the risk of someone being injured.

---

## TRAMPOLINE TECHNIQUES

### ● BASIC SKILLS

#### BASIC SKILL 1: The Basic Bounce

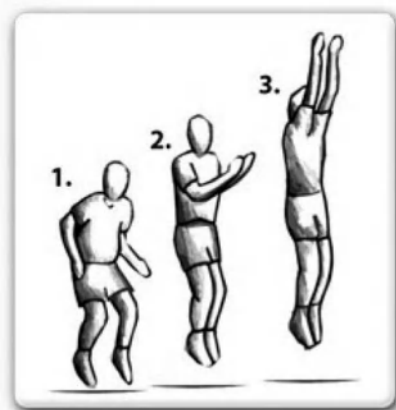

- Start from a standing position, with feet shoulder width apart head up and eyes on the trampoline bed.
- Swing arms forward and up above head in a circular motion.
- Bring legs and feet together in " mid-air " position and point toes.
- Land back on the mat with feet shoulder width apart (same as start position).
- Why not try moving onto the next skill once comfortable and proficient.

#### BASIC SKILL 2: The Knee Drop

- Start with a low basic bounce (as detailed in BASIC SKILL 1).
- Land on knees shoulder width apart, keeping back straight and a strong body position using arms out to the side or in front to maintain balance.
- Bounce back to basic bounce position by using bounce momentum and swinging arms above head.
- Once mastered at this height try bouncing a little higher, but remember to always stay in control of your height.



#### BASIC SKILL 3: The Seat Drop

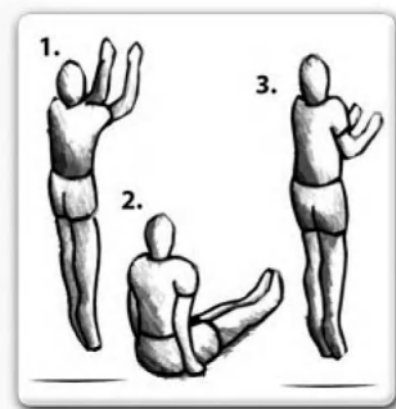

- Start with a low basic bounce (BASIC SKILL 1) in the normal
- Land with legs out straight in front of you, with hands either side of your hips and back straight in a strong body position.
- Use the bounce momentum aided with a push from hands to return to a standing position.
- Once mastered at this height try bouncing a little higher, but remember to always stay in control of your height.

**IMPORTANT:** Please consult a trained trampoline instructor before attempting any more advanced skills to ensure highest possible safety levels are maintained.

---

## TRAMPOLINE TECHNIQUES

### ● **ADVANCED SKILLS**

#### **ADVANCED SKILL 1: The Basic Bounce**

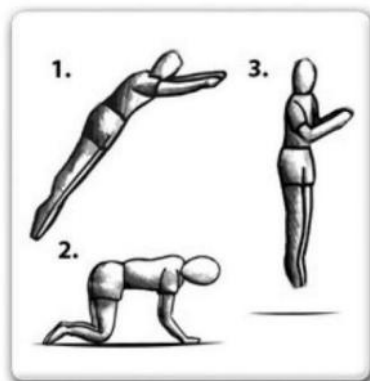

- Start with a low basic bounce (BASIC SKILL1) in the normal position.
- Land on your hands and knees at the same time, ensure that back is horizontal to the bounce mat and hands & legs are shoulder width apart also.
- Use the momentum of bounce and push off hands to regain the standing position.
- Once mastered at this height try bouncing a little higher, but remember to always stay in control of your height.
- Try moving onto the next skill once comfortable and proficient.

#### **ADVANCED SKILL 2: Hands and Knees to Front Drop**

- Land on your hands and knees at the same time, ensure the back is horizontal to the bounce mat and hands & legs are shoulder width apart also.
- Maintain strong body position with back horizontal to mat and straighten legs behind and fold arms in front of face in mid-air ready to land on the mat in a lying down position.
- Ensure the landing is done with all of body touching the mat at same time.
- Push off hands and recover the standing position.
- Once mastered at this height try bouncing a little higher, but remember to always stay in control of your height .Trying moving onto the next skill once comfortable and proficient.



#### **ADVANCE SKILL 3: The Front Drop**

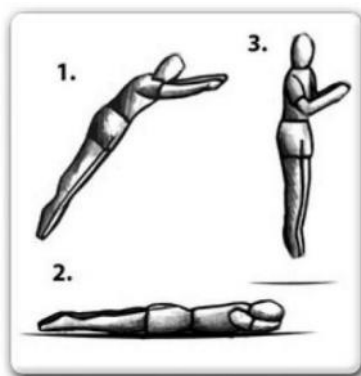

- Start with a low basic bounce (BASIC SKILL 1) in the normal position.
- Maintain strong body position with back horizontal to mat and straighten legs behind and fold arms in front of face in mid-air ready to land on the mat in a lying down position.
- Ensure the landing is done with all of body touching the mat at the same time.
- Push off hands and recover the standing position.
- Once mastered at this height try bouncing a little higher, but remember to always stay in control of your height.

**IMPORTANT:** Should you wish to progress any further and learn more advanced techniques for trampoline, please consult a qualified and registered instructor.

## TRAMPOLINE ASSEMBLY

- **STEP BY STEP CONSTRUCTION**
- **Only assemble by adult.**

To assemble this trampoline all you need is our special spring loading tool provided with this product. During periods of non-use. This trampoline can be easily disassembled and stored.

**Please read the assembly instructions before beginning to assemble the product.**

Please refer to the table for part descriptions and numbers. The assembly instruction use these descriptions and numbers as reference .

Make sure you have all parts listed. If you are missing any parts, please contact place of purchase.

**Please use gloves to protect your hands from pinch points during assembly. When you are ready to start, make sure that you have plenty of space and a clean dry area for assembly.**

## TRAMPOLINE PARTS LIST

Ref. Number	Description	Unit	8'	10'	12'	14'	15'	16'
1	Trampoline Mat, stitched with V-Rings	Pcs	1	1	1	1	1	1
2	Frame Pad	Pcs	1	1	1	1	1	1
3	Top Rail	Pcs	6	8	8	8	12	12
4	Leg Base	Pcs	3	4	4	4	6	6
5	Vertical Leg Extension	Pcs	6	8	8	8	12	12
6	Springs	Pcs	48	64	72	80	96	108
7	User manual	Pcs	1	1	1	1	1	1
8	Spring tool	Pcs	1	1	1	1	1	1
9	Screw of legs	Pcs	12	16	16	16	24	24
10	Connector	Pcs	6	8	8	8	12	12
11	Spanner	Pcs	1	1	1	1	1	1

Enclosed are the current specifications and product features available at time of printing, however, changes may be made in equipment, availability, specifications and features without notice.

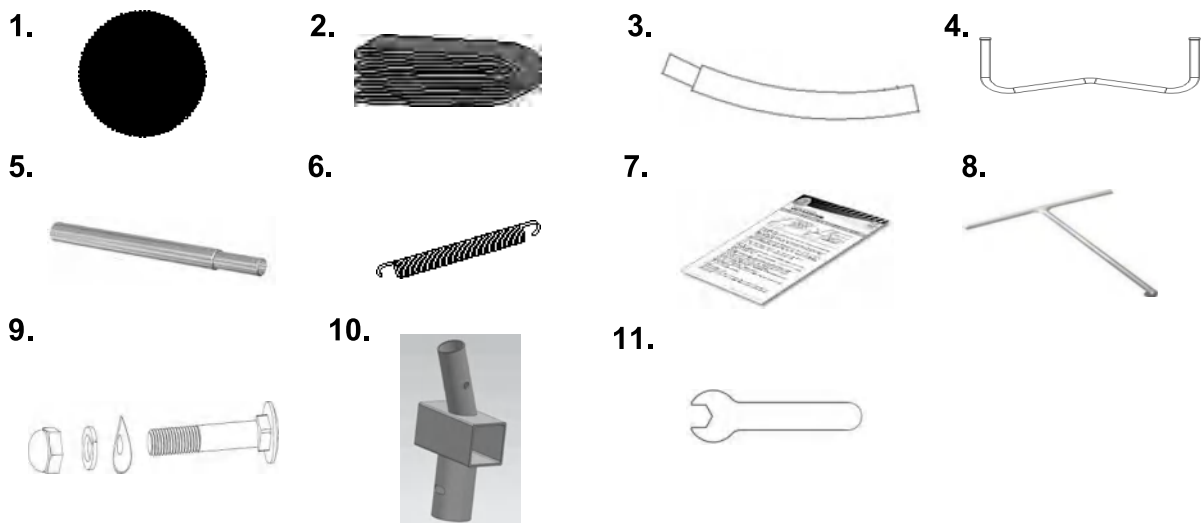

---

## Frame layout

Please use the parts list table on other page to identify and layout all the parts as pictures, select which size trampoline you have purchased first, then refer to the following pictures.

All the “ Top rail with Tconnector ”, are universal parts and can only go together in one way.

To connect the parts, simply slide the thinner end of the tubing into the adjacent section with the larger opening.

These joints are called “ connector points”.

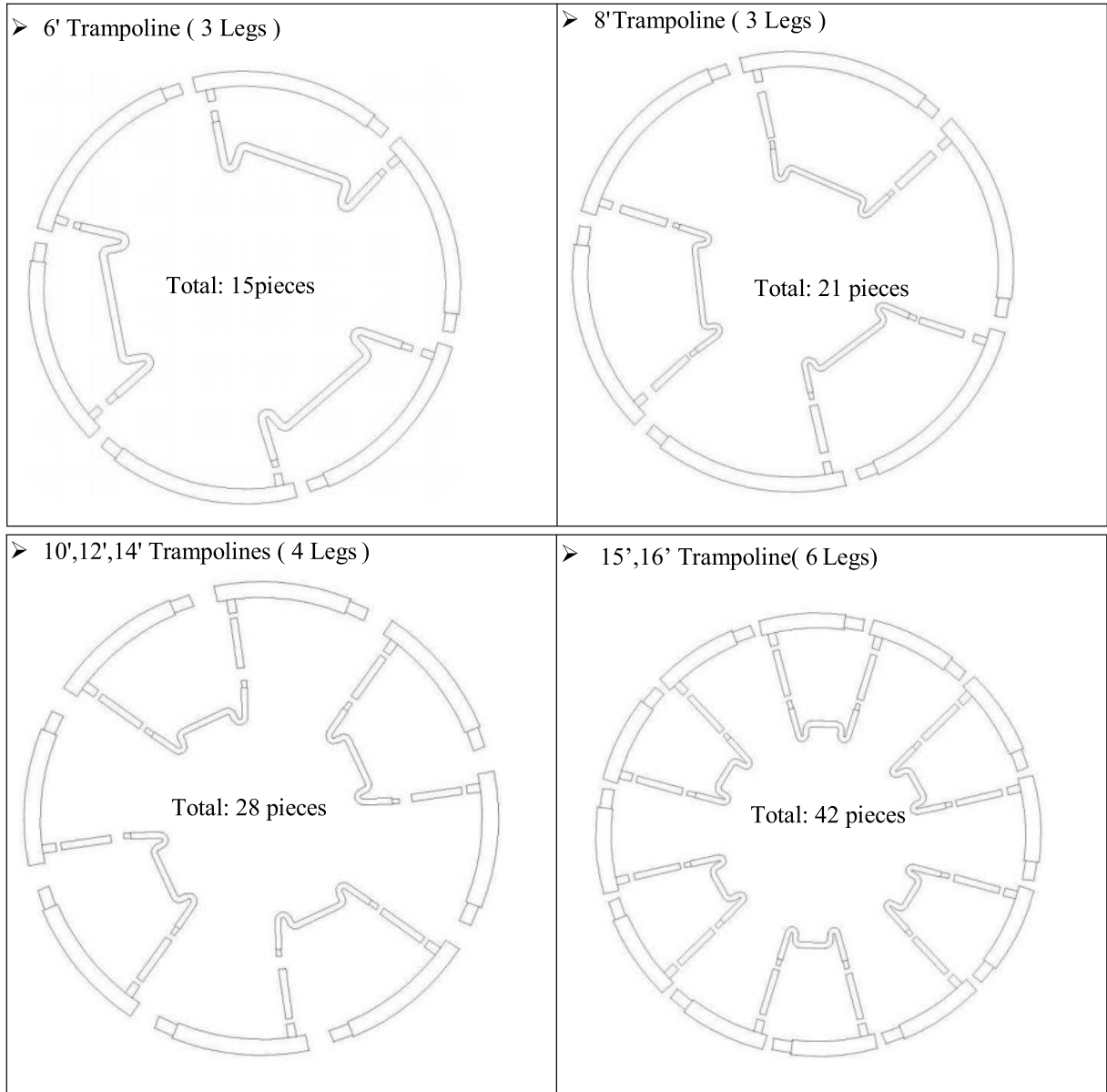

## STEP 1: - Top Frame and Leg Extension Assembly

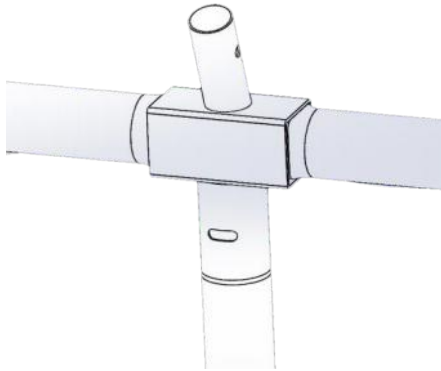

FIG 1

- Using one T Connector (10) connect two frame pieces (3).
- Insert one leg extension pole (5) into each leg socket in the T Section.

## STEP 2: Leg Base Assembly

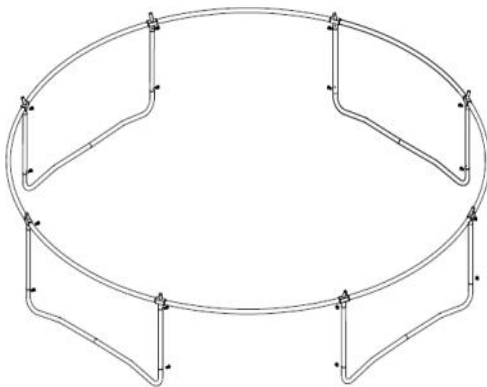

FIG 2

- On the end of the frame assembly made in step one install another T Connector and Leg Extension pole.
- Insert a leg base (4) into the leg extensions. It should now look like one of the sections in the image to the left.

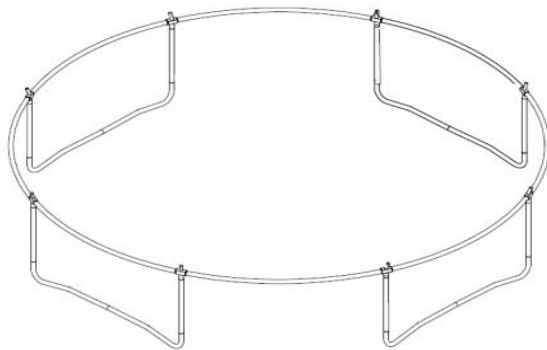

FIG 3

- Lay the sections out as shown in Fig 2.
- **From this point two people are needed** to finish putting the frame together as below.

**STEP 3: - Trampoline Mat Assembly**

**WRNING:** Attaching springs, the connector points can become pinch points since the trampoline is tightening up. With this in mind please be careful attaching springs to the trampoline mat. Please be careful.

You will need at least one person to help with this portion of assembly.



Layout the “**Trampoline Mat**” inside the frame on the floor as picture above

**STEP4: ATTACHING THE SPRINGS TO TRAMPOLINE MAT**

The springs need to be placed in position as shown in the diagram to the right, in order to pull the " Trampoline Mat " in all four directions .

The image to the right specifies and details the spring positions to hold the " Trampoline Mat " in place. Please see the table for the positions of springs for the different sizes of Trampoline :

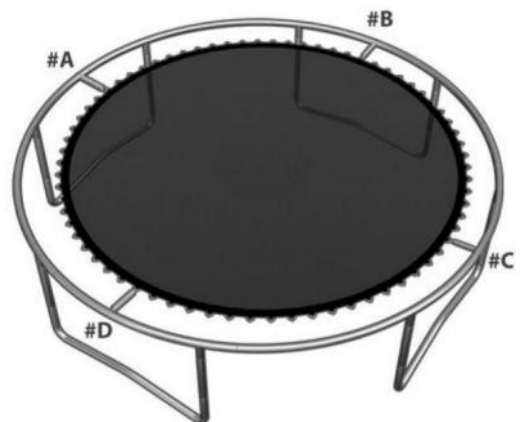

<i>Trampoline</i>	<i>#A</i>	<i>#B</i>	<i>#C</i>	<i>#D</i>
<i>8FT trampoline</i>	1	13	25	37
<i>10FT trampoline</i>	1	14	28	42
<i>12FT trampoline</i>	1	19	37	55
<i>13FT trampoline</i>	1	21	41	61
<i>14FT trampoline</i>	1	23	45	67
<i>15FT trampoline</i>	1	26	51	76
<i>16FT trampoline</i>	1	28	55	82

## HOW TO USE THE " SPRING LOADING TOOL "

Firstly hang one side of spring on the triangle attached to the " **Trampoline Mat** ", and use the " **spring tool** " to hook the other side of spring (As shown in the top image to the right) .

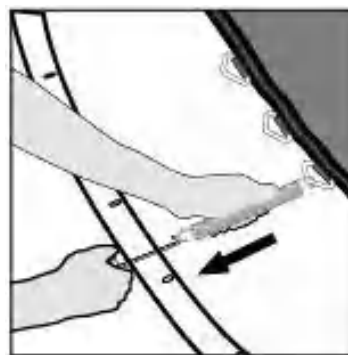

Pull the " Spring Tool " until the spring hook insert the hole on the "trampoline frame" and disengage the " Spring Tool " leaving the " Spring " in place. Repeat process for all springs .

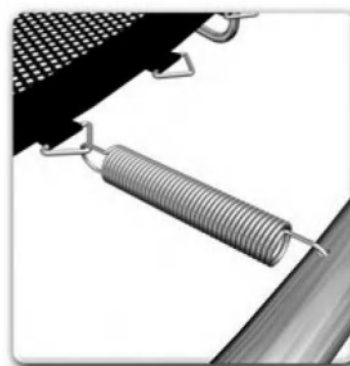

**WARNING!!** : Please be careful where your hands and other parts of the body are placed as the connector points and spring attachments can create hand or body traps.

## STEP 5-Frame Pad Assembly

A. Lay the Frame Pad over the trampoline so that the springs and the steel frame is covered.

Please ensure that the Frame Pad covers all metal parts.

B. Tie the strap located at the under side of the frame pad to the frame.

C. Select your Pad model.

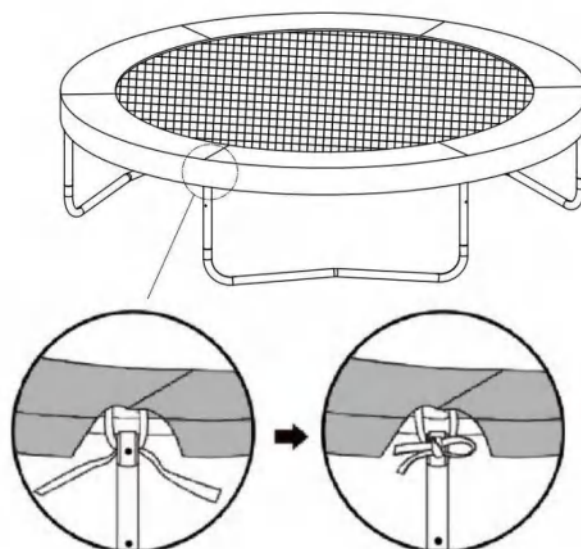
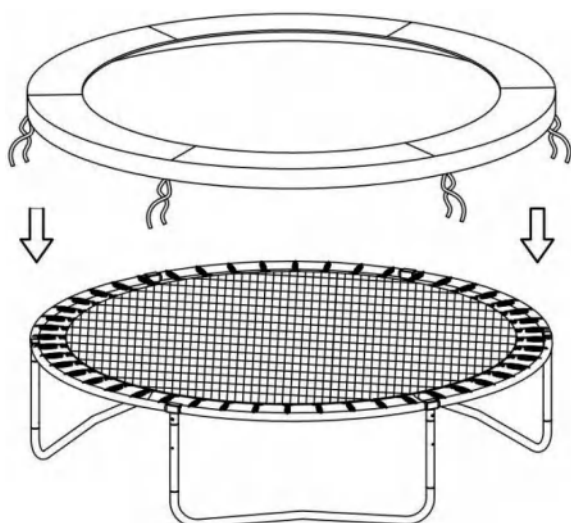

---

## CARE AND MAINTENANCE

This trampoline was designed and manufactured with quality materials and craftsmanship. If proper care and maintenance is provided, it will provide all jumpers with years of exercise, fun, and enjoyment as well as reduce the risk of injury. Please follow the guidelines listed below:

This trampoline is designed to withhold a certain amount of weight and use. Please make sure that only one person at any one time uses the trampoline. Also, the person should weigh less than 333 pounds (150kgs). Jumpers should either wear socks, gymnastics shoes, or be barefoot when using the trampoline. Please be aware that street shoes or tennis shoes should NOT be worn while using the trampoline. In order to prevent the trampoline mat from getting cut or damaged please do not allow any pets onto the mat. Also, jumpers should remove all sharp objects from their person prior to using the trampoline. Any type of sharp or pointed objects should be kept off the trampoline mat at all times.

Always inspect the trampoline before each use for worn, abused or missing parts. A number of conditions could arise that may increase your chances of getting injured. Please be aware of:

- Punctures, holes, or tears in the trampoline mat
- Sagging trampoline mat
- Loose stitching or any kind of deterioration of the mat
- Bent or broken frame parts, such as the legs
- Broken, missing, or damaged springs
- Damaged, missing, or insecurely attached frame pad
- Protrusions of any types (especially sharp types) on the frame, springs, or mat

**IF YOU FIND ANY OF THE PREVIOUS CONDITIONS, OR ANYTHING ELSE THAT YOU FEEL COULD CAUSE HARM TO ANY USER, THE TRAMPOLINE SHOULD BE DISASSEMBLED OR SECURED FROM USE UNTIL THE CONDITION(S) HAS BEEN RESOLVED.**

### WINDY CONDITIONS

In severe wind situations, the trampoline can be blown about. If you expect windy weather conditions, the trampoline should be moved to a sheltered area or disassembled. Another option is to tie the round, outside portion (top frame) of the trampoline to the ground using ropes and stakes. To ensure security, at least three (3) tie downs should be used. Do not just secure the legs of the trampoline to the ground because they can pull out the frame sockets.

### MOVING THE TRAMPOLINE

If you need to move the trampoline, two people should be used. All connector points should be wrapped secured with weather resistant tape, such as duct tape. This will keep the frame intact during the move and prevent the connector points from dislocating and separating. When moving, lift the trampoline slightly off the ground and keep it horizontal to the ground. For any type of other move, you should disassemble the trampoline.

# ENCLOSURE PARTSLIST

## Parts List

Reference Number	Description	8'	10'	12'	14'	15'	16'
1	Bottom tube	6pcs	8pcs	8pcs	8pcs	12pcs	12pcs
2	Top tube	6pcs	8pcs	8pcs	8pcs	12pcs	12pcs
3	Pole Cover	6pcs	8pcs	8pcs	8pcs	12pcs	12pcs
4	Safety Net	1 pc	1 pc	1 pc	1 pc	1 pc	1 pc
5	Fiberglass Rod	8pcs	10pcs	12pcs	14pcs	15pcs	16pcs
6	Galvanized. Connector	8pcs	10pcs	12pcs	14pcs	15pcs	16pcs
7	Rope	5 pcs	6 pcs	7 pcs	8 pcs	9 pcs	10pcs

## Diagram for Parts

1. Bottom tube



2. Top tube



3. Pole Cover



4. Safety Net



5. Fiberglass Rod



6. Galvanized Connector



7. Rope



**WARNING: READ AND FOLLOW THIS INSTRUCTION, PRIOR TO ASSEMBLE AND USE OF THIS EQUIPMENT.**

---

**STEP 1 -Net Pole Assembly**

- A. Connect the bottom tube and top tube. Insert these into the PE sleeve (see pictures)

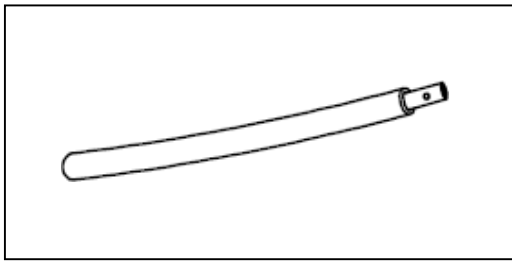

Bottom tube

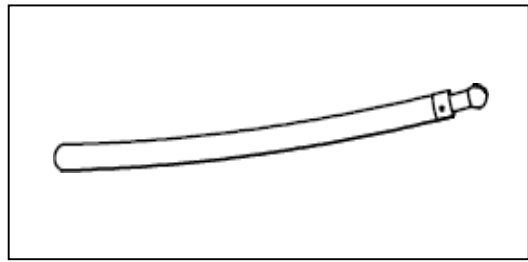

Top tube

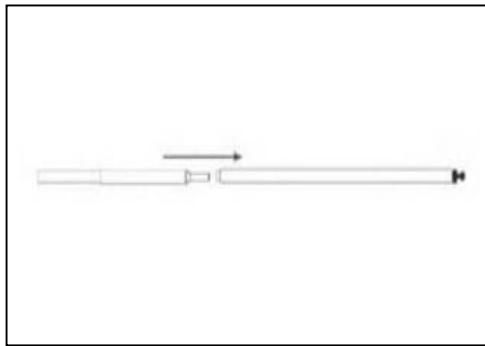

Connecting two tubes

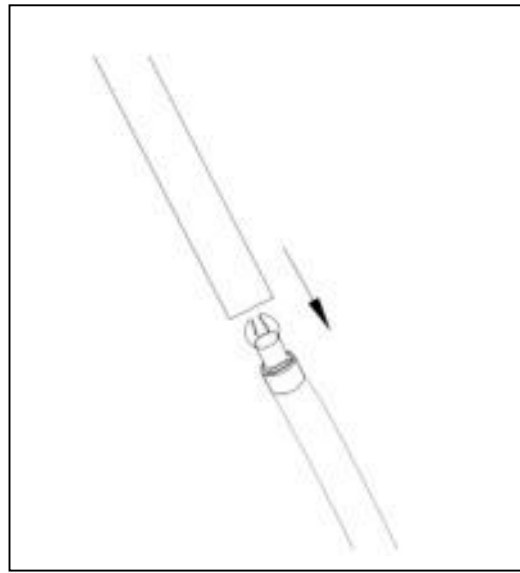

PE sleeve

- B. Clip each of the pole assemblies into the T sections on the trampoline.

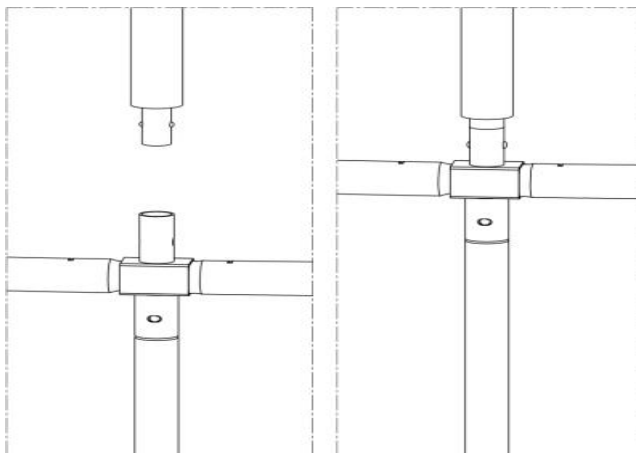

---

## STEP 2 - Fiberglass Rod Assembly

A. After assemble the pole tube, let's assemble the fiber glass and net, lie the net flat as shown. Run two even lengths of the rods through the loops at the top of the net. One person hand two of the ends of rods while another one pushes forward and connects A side of net as per picture, to make the last connection have one person hand on the opposite B side. Push the rods towards the centre of ring until they are in the line with each other and make the last connection.

Assemble two even lengths of fiberglass rods (5) using the galvanized connectors (6) as shown below. At least needs 2 person, 3 will be better

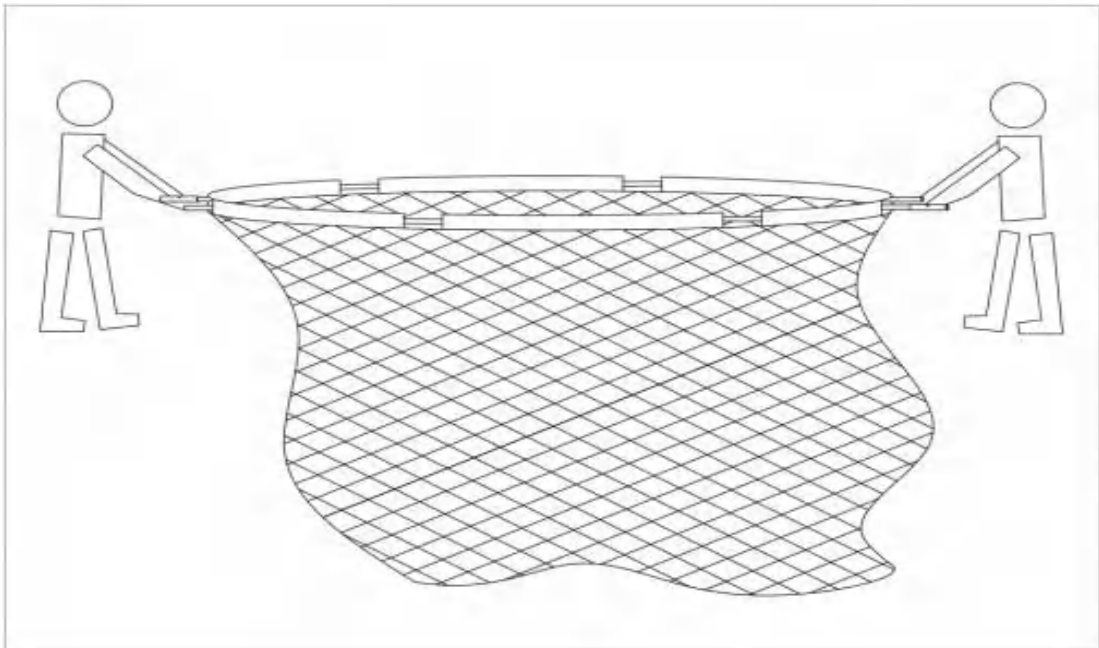
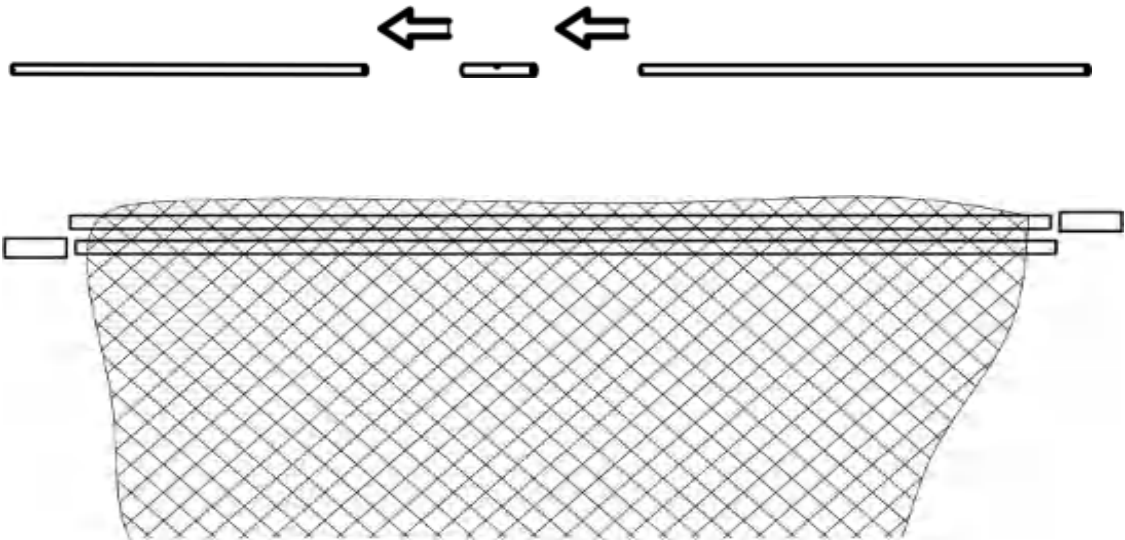

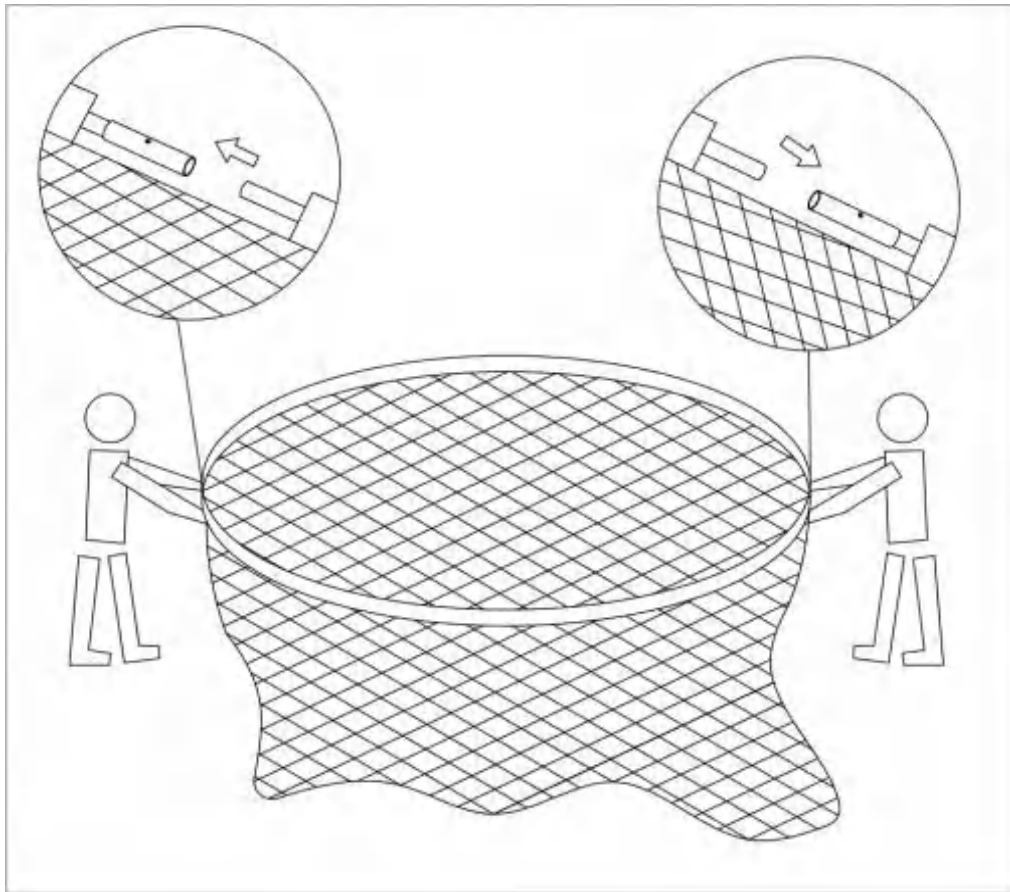

**STEP 3 – Securing Net.**

Raise the net up into position and clip the ring into the Top Caps

Top Cap



---

#### STEP 4 –Safety fixation

Starting from the door, secure the safety net to the jump mat with ropes(7) at the bottom of the safety net.

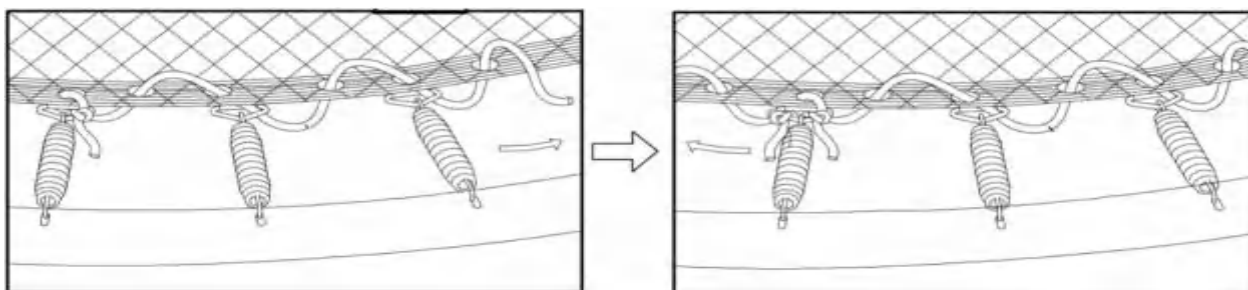
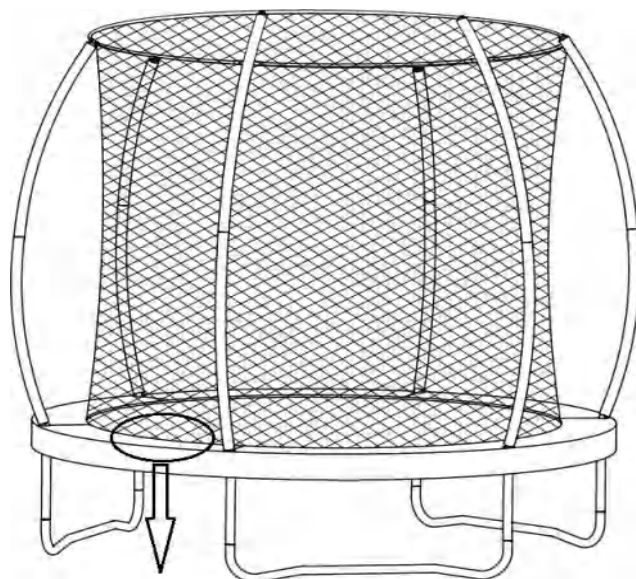

- Important-

For your safety, make sure to securely fasten enclosure entrance prior to using trampoline with safety net.



## **IMPORTANT WARNING!!**

**YOU SHOULD GO BACK NOW AND STRETCH ALL ATTACHMENT HOOKS TIGHT AND DOUBLE CHECK TO SEE WHETHER YOU HAVE FASTENED THE SCREW AND BOLT OR NOT, SO THE SAFETY NET STANDS STIFF. OTHERWISE, THE SAFETY NET WILL NOT FUNCTION PROPERLY. THEN FINISH ASSEMBLING.**

## **TESTING THE TRAMPOLINE**

After assembling the trampoline, it is important that you perform the following safety checks:

### **Trampoline Safety Checks:**

- **Using a screwdriver, check if all the screws are tightly secured.**
- **Look underneath the trampoline and check all the springs are hooked securely to the frame and triangle rings.**
- **Move the trampoline around and check the sturdiness of the frame.**
- **Using your two hands, put your body weight on one section of the trampoline and release to check that the floor is even.**
- **Inspect the cover pads and check if they completely cover the springs and frame.**
- **Make sure the strings of the pads are tied securely.**
  
- **Enclosure Net Safety Checks:**
  - **Hold onto pole net jacked and check that all the enclosure poles are sturdy by shaking it.**
  - **Check the enclosure net and pole jacket for any tearing in the stitching or material.**
  - **Check the enclosure net zipper and entrance hooks function properly.**
  - **Check to see if all safety enclosure hooks are attached to the triangle ring underneath the trampoline**

**Once all the checks are performed and the trampolines are passed all the initial test (above), then test the trampoline by jumping on the centre continuously for 5 minutes. If the trampoline feels sturdy then you passes the test. Remember to abide by all the safety rules. Have fun, play safe**

---

# USER MANUAL FOR LADDER (2 STEP/ 3 STEP)

## WARNING & INSTRUCTION

- Please read the assembly instructions before beginning to assemble the product.
- Please refer to the table for part descriptions and numbers. The assembly instruction use these descriptions and numbers as reference.
- Make sure you have all parts listed. If you are missing any parts, please contact place of purchase.
- Only assemble by adult.

## LADDER PART LIST

Ref.number	Part. number	Description	Unit (pcs)
1	LD001	Frame poles	2
2	LD002	Step poles	2 or 3
3	LD003	Screws	4 or 6
4	LD004	Manual	1

# LADDER ASSEMBLY

## Step 1. Frame install

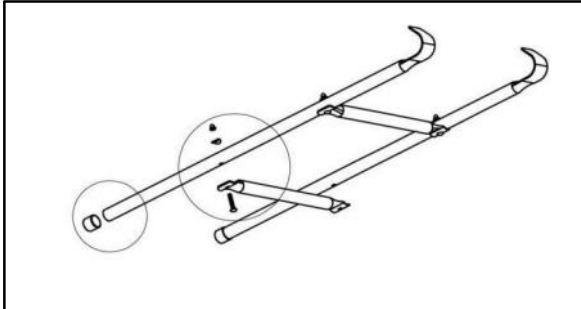

Layout all of the parts as pictures. select two frame pole which have two or three holes.

## Step 2 Install screws

Pls install all of the screws use toolas show.

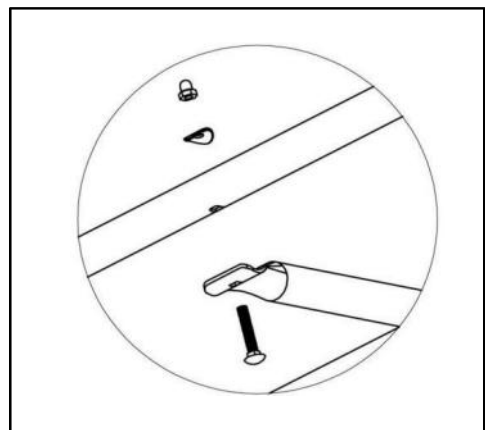
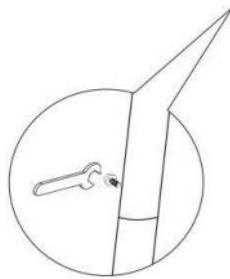

## Step 3. Install Finished

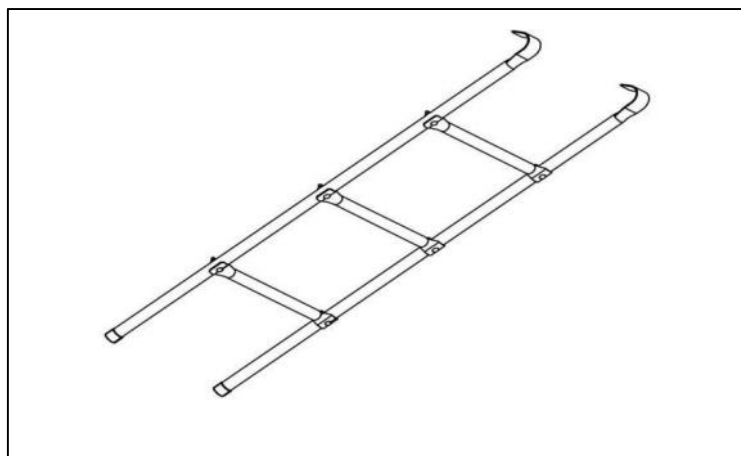

# USER MANUAL

(FOR TP TD TRAMPOLINE)

## BASKETBALL HOOP ATTACHMENT

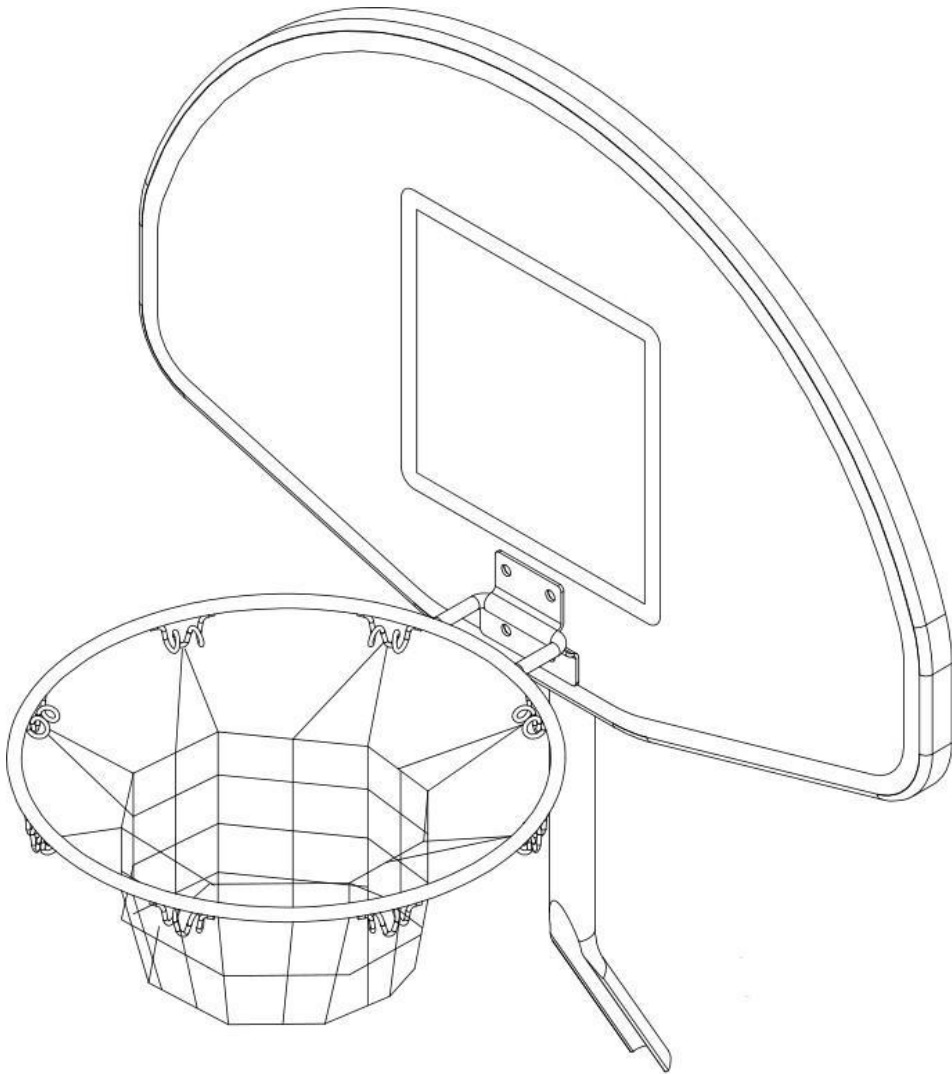





## Adult Supervision

1. Adult assembly required.
2. Adult supervision required for children using basketball board.

### ATTENTION:

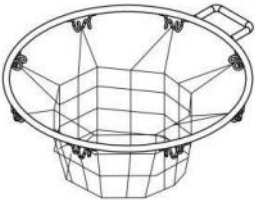
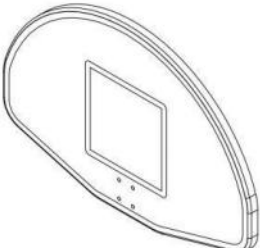
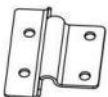
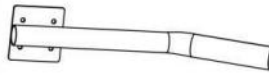
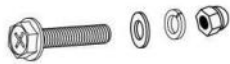
1. Please read and follow all instructions before you use your basketball hoop attachment.
2. Please check all of the parts in the carton before you install your basketball hoop attachment.
3. Ladder is recommend to install the basketball hoop part.

### Part list:

 A 1PC	 B 1PC	 C 1PC	 D 1PC
 E (M6×28) 4PCS	 F (M6×20) 2PCS	 G 1PC	 H 1PC
 I 2PC			

## Instructions for Installation

Step 1: Assemble the hoop and bracket.

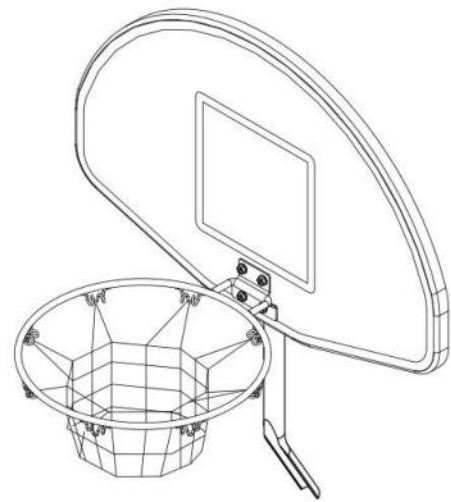
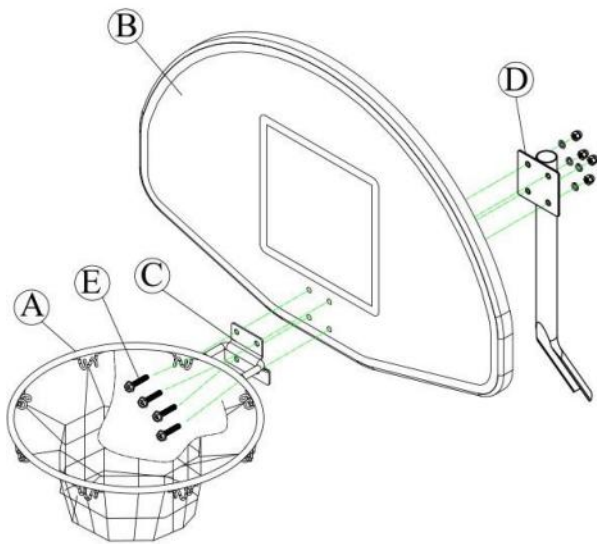

Step 2: Assemble the board on the trampoline  
(Need to remove the foam and lower the sleeve.)

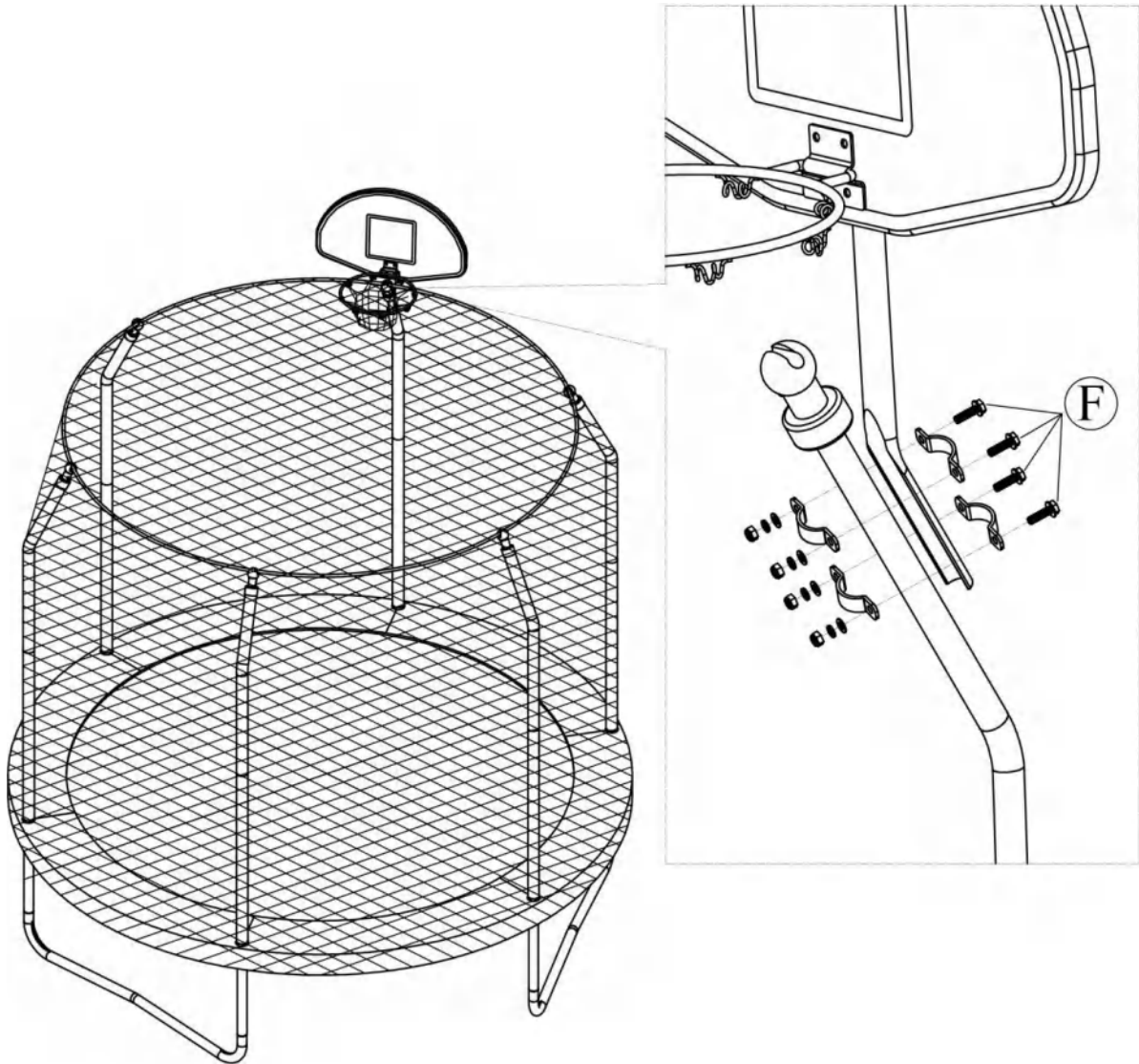

⚠ You can shoot the ball into the basketball hoop but please do not jump dunk, or you may damage the trampoline or hurt yourself

Congratulations you have successfully installed Basketball Hoop Set!

