

ASSEMBLY INSTRUCTIONS INSTRUCTIONS DE MONTAGE

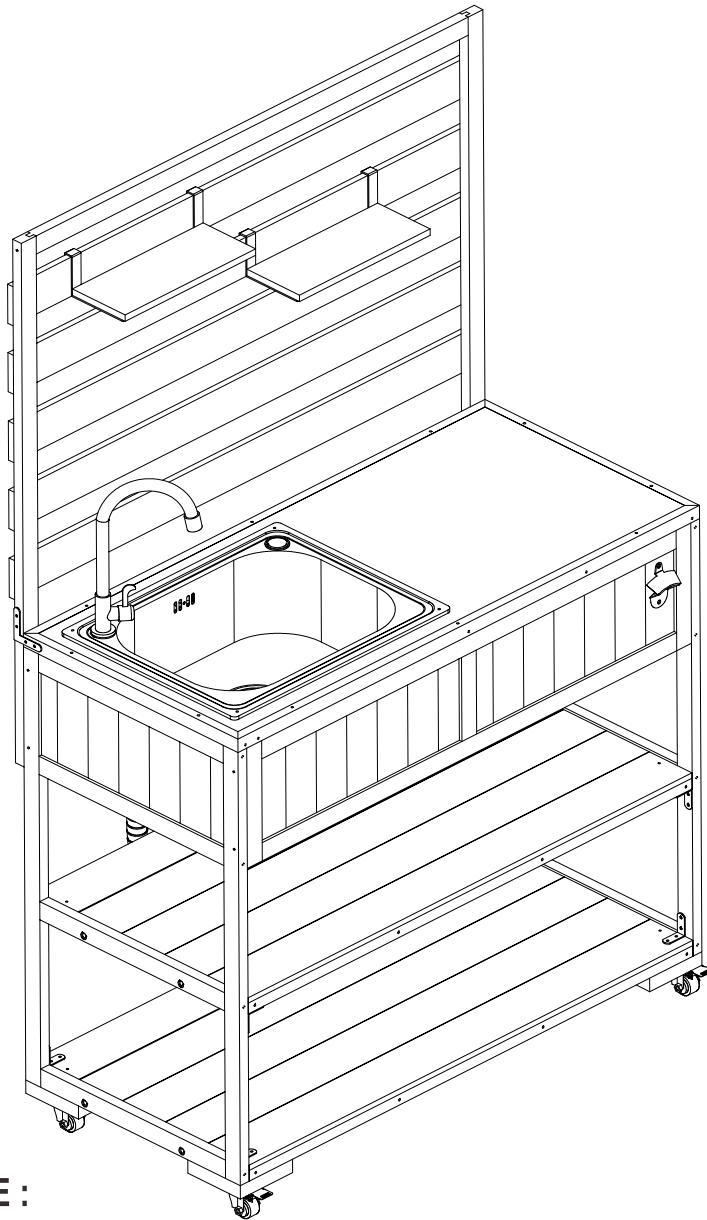

IMPORTANT NOTE :

- ① PLACE ALL PARTS ON A CLEAN AND SMOOTH SURFACE SUCH AS A RUG OR CARPET TO AVOID THE PARTS FROM BEING SCRATCHED.
- ② BEFORE YOU BEGIN, KINDLY FOLLOW THE ASSEMBLY INSTRUCTIONS STEP BY STEP.
- ③ DO NOT TIGHTEN ALL SCREWS AND BOLTS UNTIL THIS ITEM IS FULLY SET-UP.







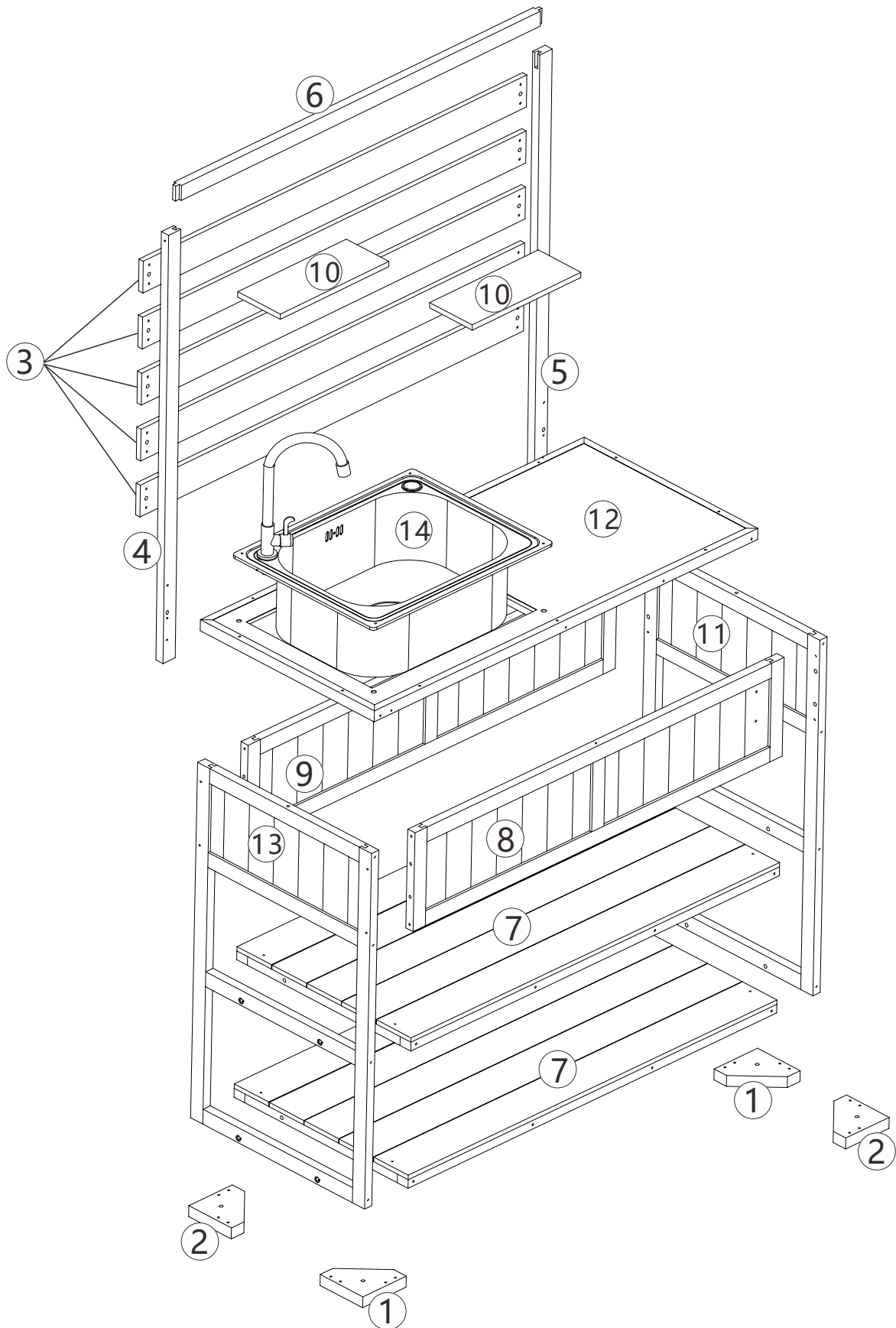

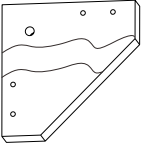
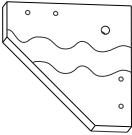

NOTE IMPORTANTE:

- ① PLACEZ TOUTES LES PIÈCES SUR UNE SURFACE PROPRE ET LISSE TELLE QU'UN TAPIS OU UN TAPIS POUR ÉVITER LES PIÈCES D'ÊTRE RAYÉES.
- ② AVANT DE COMMENCER, VEUILLEZ SUIVRE LES INSTRUCTIONS D'ASSEMBLAGE ÉTAPE PAR ÉTAPE.
- ③ NE SERREZ PAS TOUTES LES VIS ET LES BOULONS TANT QUE CET ARTICLE N'EST PAS ENTIÈREMENT INSTALLÉ.

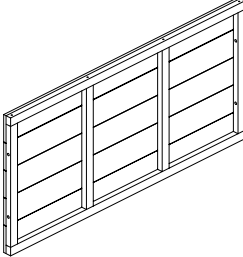
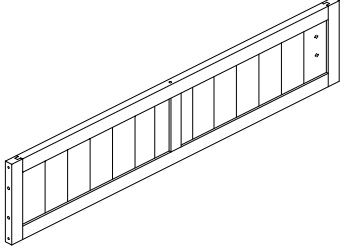
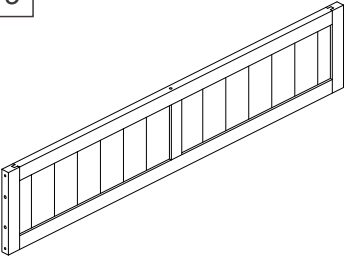
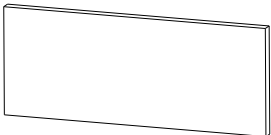
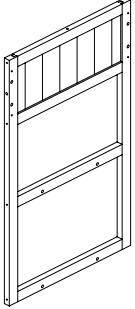
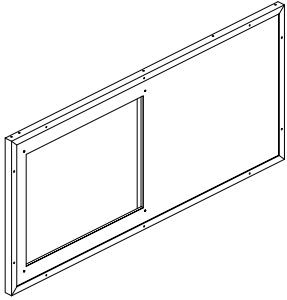
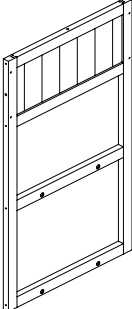











Detail View Vue détaillée

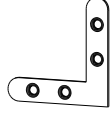
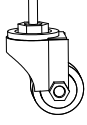
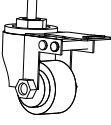
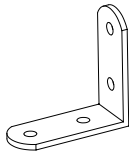
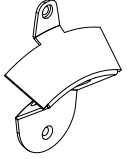
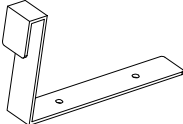

Part List
Liste des pièces

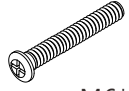
<p>1</p> 	<p>2</p> 	<p>3</p> 	<p>4</p> 
<p>Base 1 2PCS</p>	<p>Base 2 2PCS</p>	<p>Shelf panel Panneau d'étagère 5PCS</p>	<p>Left vertical partition of the storage rack Cloison verticale gauche du rayonnage de stockage 1PC</p>
<p>5</p> 	<p>6</p> 	<p>7</p> 	<p>8</p> 
<p>Right vertical partition of the storage rack Cloison verticale droite du rayonnage de stockage 1PC</p>	<p>The slat of storage rack La latte du rayonnage de stockage 1PC</p>	<p>Bottom panel Panneau inférieur 2PCS</p>	<p>Front panel Panneau avant 1PC</p>
<p>9</p> 	<p>10</p> 	<p>11</p> 	<p>12</p> 
<p>Back panel Panneau arrière 1PC</p>	<p>Movable shelf panel Panneau d'étagère mobile 2PCS</p>	<p>Right side panel Panneau latéral 1PC</p>	<p>Table top Dessus de table 1PC</p>
<p>13</p> 	<p>14</p> 	<p>15</p> 	<p>16</p> 
<p>Left side panel Panneau latéral gauche 1PC</p>	<p>Basin Bassin 1PC</p>	<p>Faucet Robinet 1PC</p>	<p>Supply pipe Conduite d'alimentation 1PC</p>
<p>17</p> 	<p>18</p> 	<p>19</p> 	
<p>Bottle trap Piège à bouteille 1PC</p>	<p>Drain pipe Tuyau d'évacuation 1PC</p>	<p>Return water pipe Conduite de retour d'eau 1PC</p>	

Hardware List
Liste du matériel

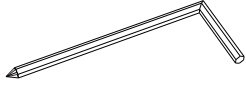
<p>A</p>  <p>3.5*60 Ph zinc screws Vis de zinc ph 2+1 pcs</p>	<p>B</p>  <p>3.5*40 Ph zinc screws Vis de zinc ph 40+1 pcs</p>	<p>C</p>  <p>3.5*25 Ph zinc screws Vis de zinc ph 20+1 pcs</p>	<p>D</p>  <p>3.0*16 Ph zinc screws Vis de zinc ph 44+1 pcs</p>
<p>E</p>  <p>Wood dowel Cheville à bois 22+2 pcs</p>	<p>F</p>  <p>Ground nail Clou de sol 2 pcs</p>	<p>G</p>  <p>L shape metal Métal en forme de L 2 pcs</p>	<p>H</p>  <p>Right-angle iron Cornière en fer 2 pcs</p>
<p>I</p>  <p>Fixed wheel Roue fixe 2 pcs</p>	<p>J</p>  <p>Brake wheel Roue de frein 2 pcs</p>	<p>K</p>  <p>Corner brace Équerre d'angle 8 pcs</p>	<p>L</p>  <p>Bottle opener Ouvre-bouteille 1 pc</p>
<p>M</p>  <p>Hook Crochet 4 pcs</p>	<p>N</p>  <p>M6*15 Ph zinc bolt Boulon de zinc ph 2+1 pcs</p>	<p>O</p>  <p>M6*55 Ph zinc bolt Boulon de zinc ph 8+1 pcs</p>	<p>P</p>  <p>4.0*18 Round head screw Vis à tête ronde 4+1 pcs</p>
<p>Q</p>  <p>3.0*12 Ph zinc screws Vis de zinc ph 8+1 pcs</p>	<p>R</p>  <p>Open-end Wrench Clé à fourche 1 pc</p>	 <p>L shape wrench Clé en L 1 pc</p>	

ASSEMBLY TOOLS REQUIRED(NOT INCLUDED)
OUTILS D'ASSEMBLAGE REQUIS (NON INCLUS)



PLEASE BE CAREFUL DO NOT DAMAGE THE HOLE POSITION WHEN YOU USE POWERTOOLS!

VEUILLEZ FAIRE ATTENTION À NE PAS ENDOMMAGER LA POSITION DU TROU LORS DE L'UTILISATION D'OUTILS ÉLECTRIQUES!

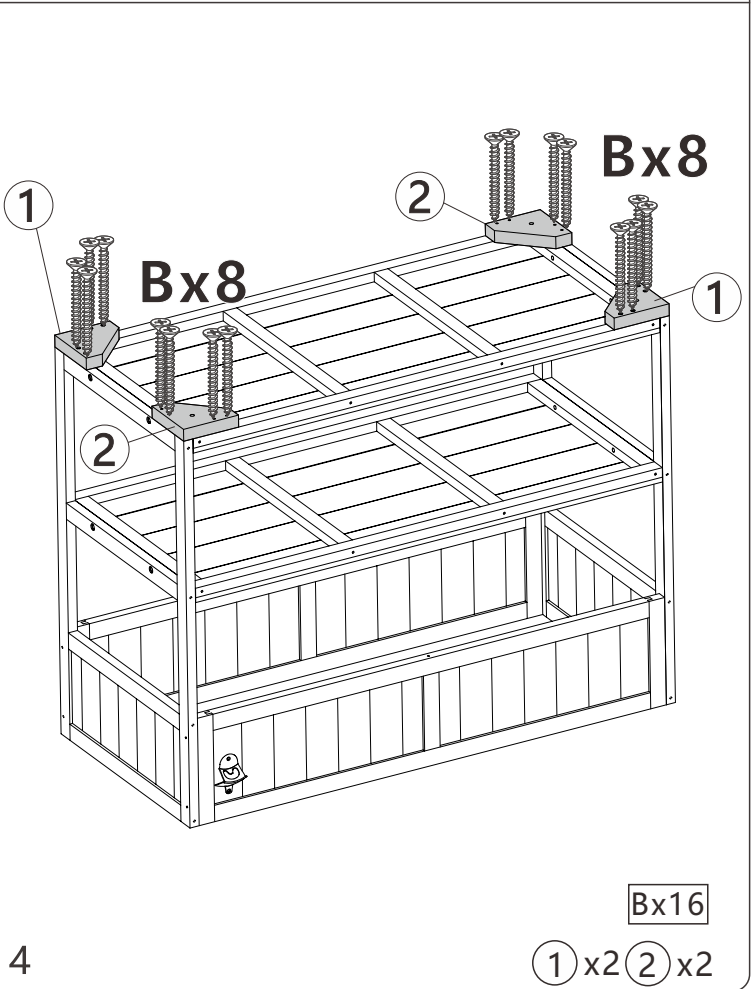
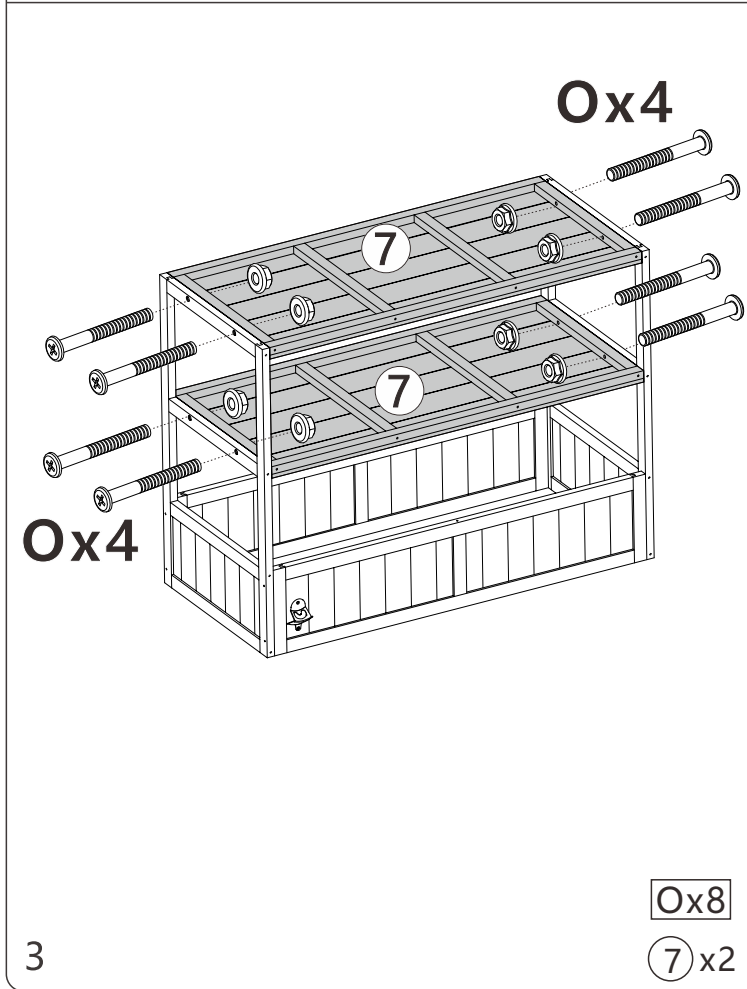
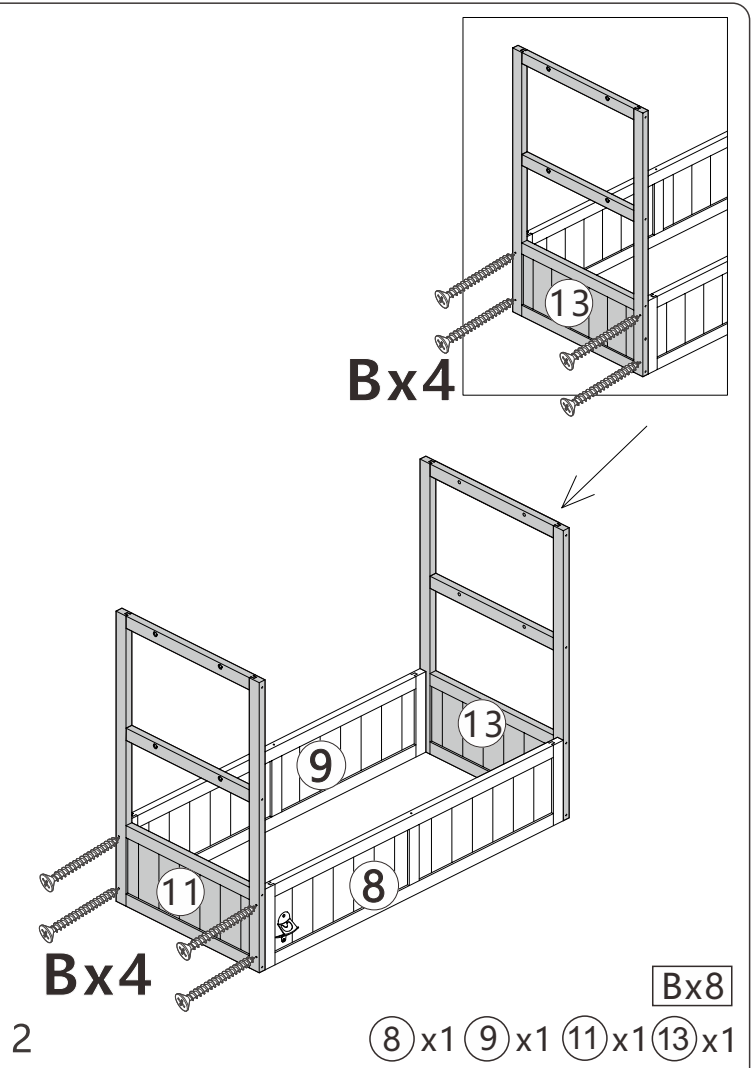
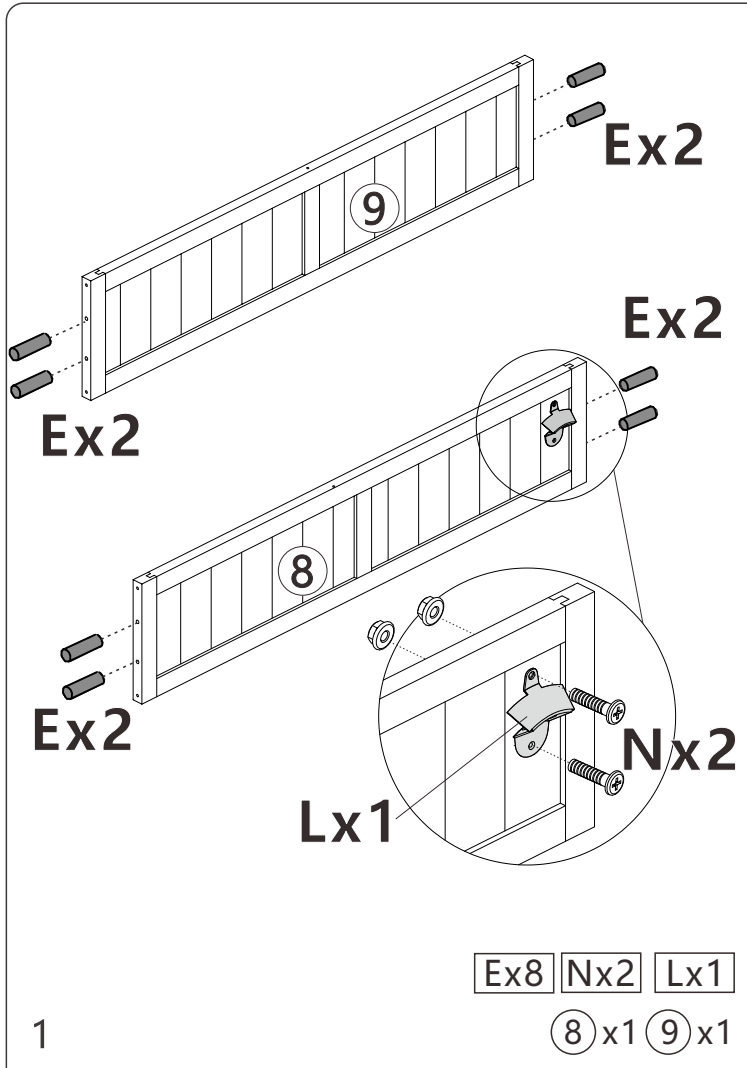

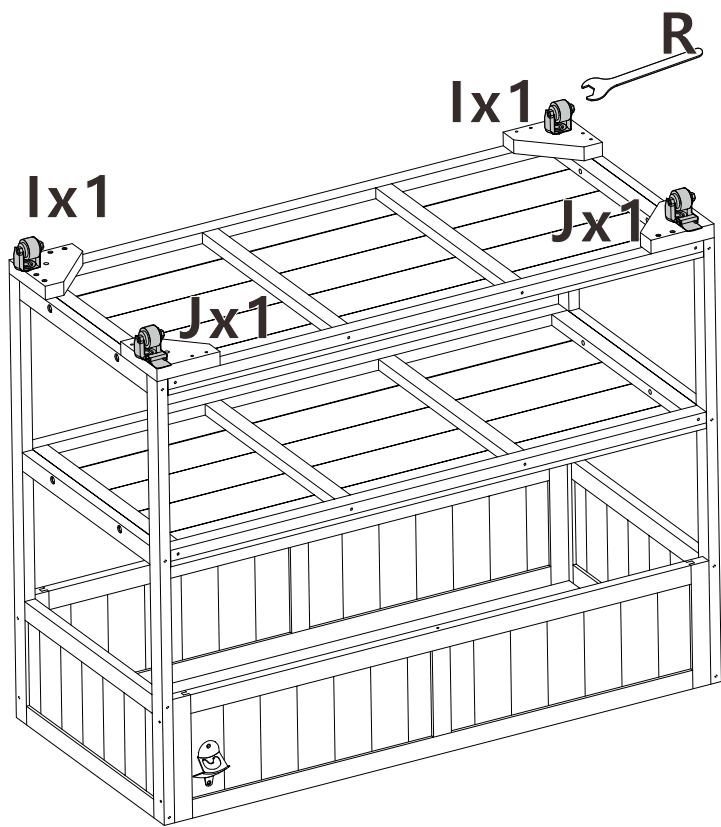

5

I x 2 J x 2 R x 1

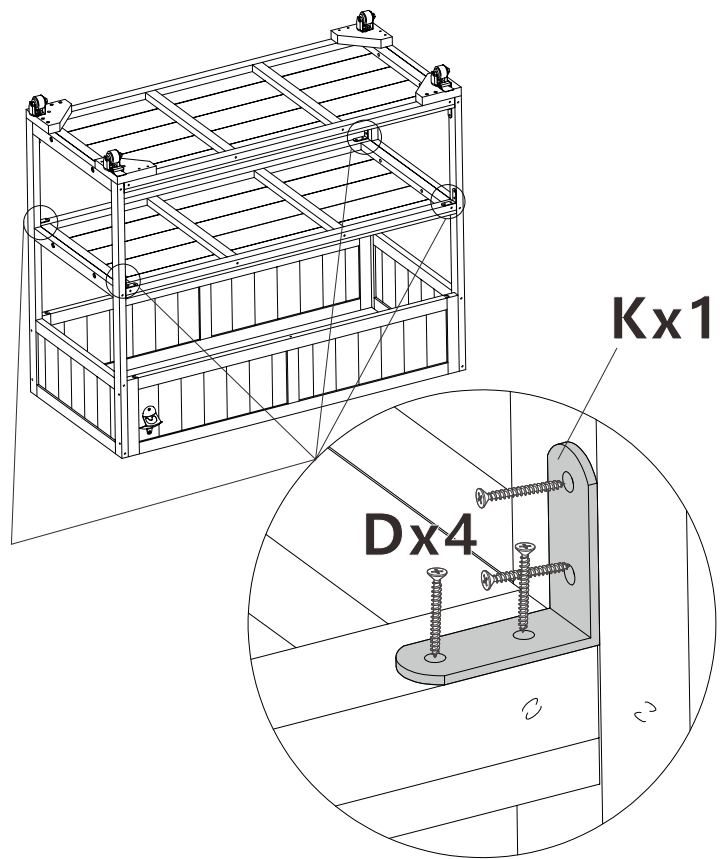

Level with the outside
Au même niveau que l'extérieur

6

D x 16 K x 4

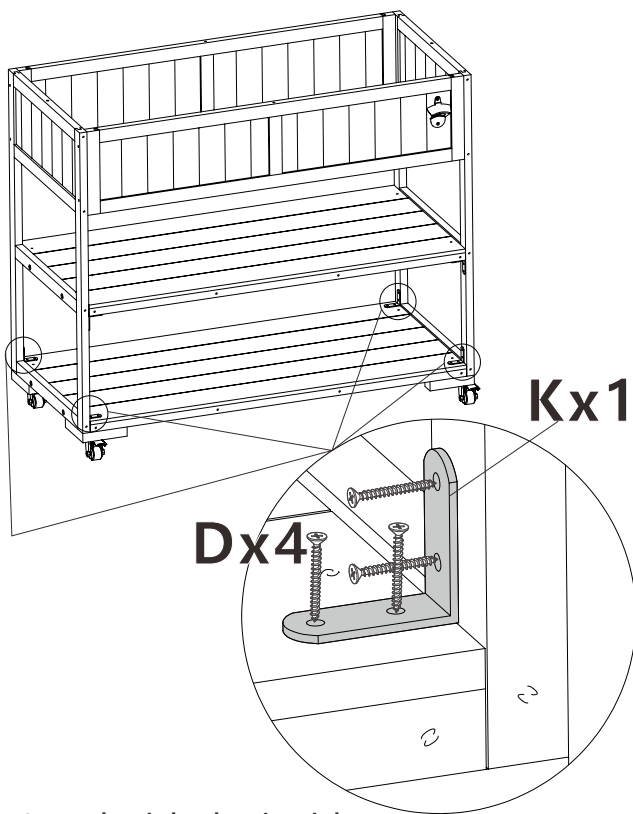

Level with the inside
Au niveau de l'intérieur

7

D x 16 K x 4

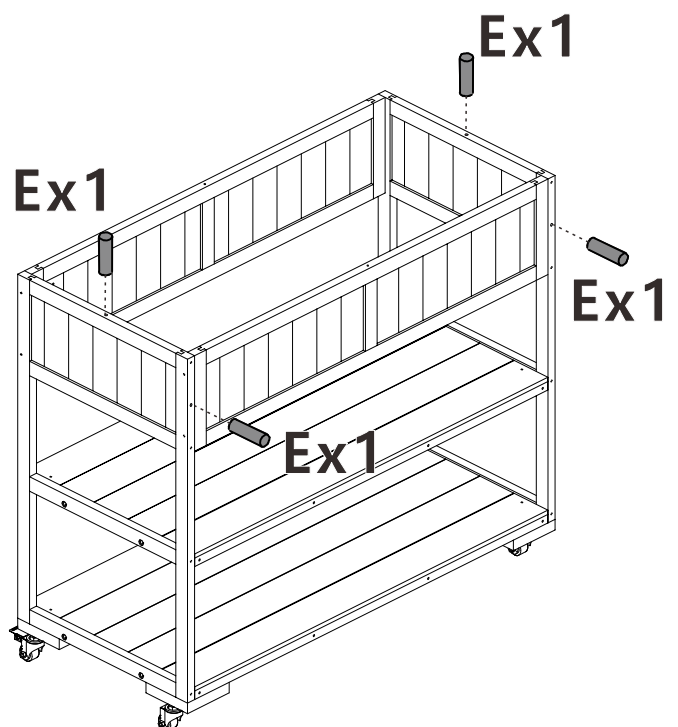

8

Ex 4

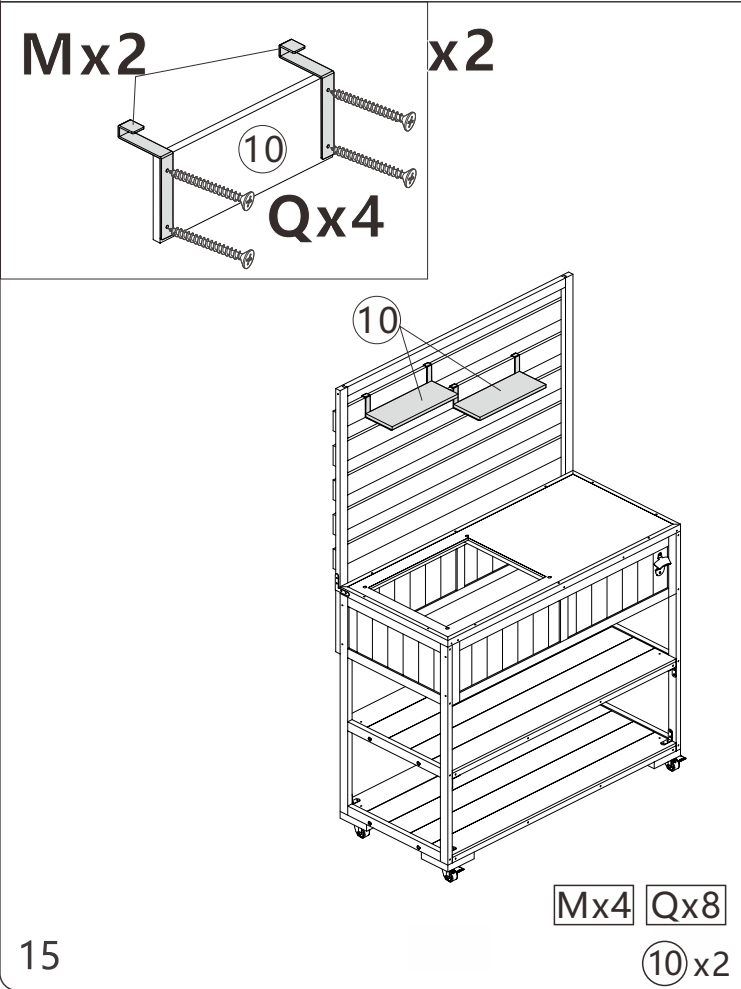
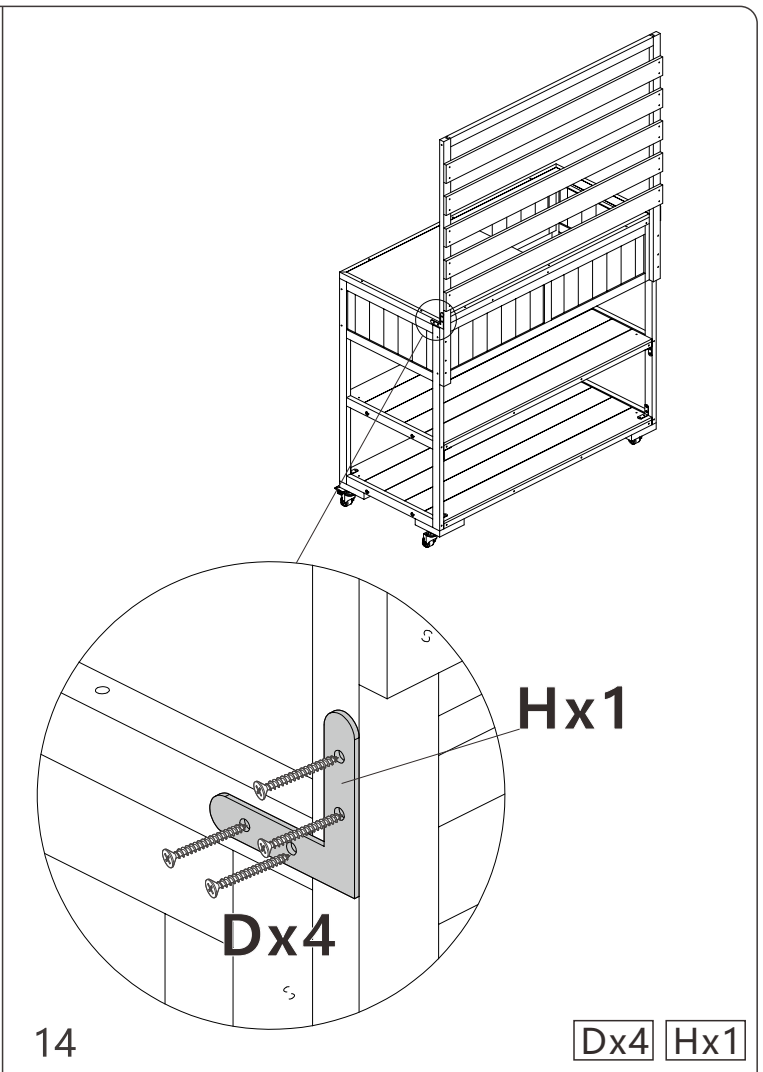
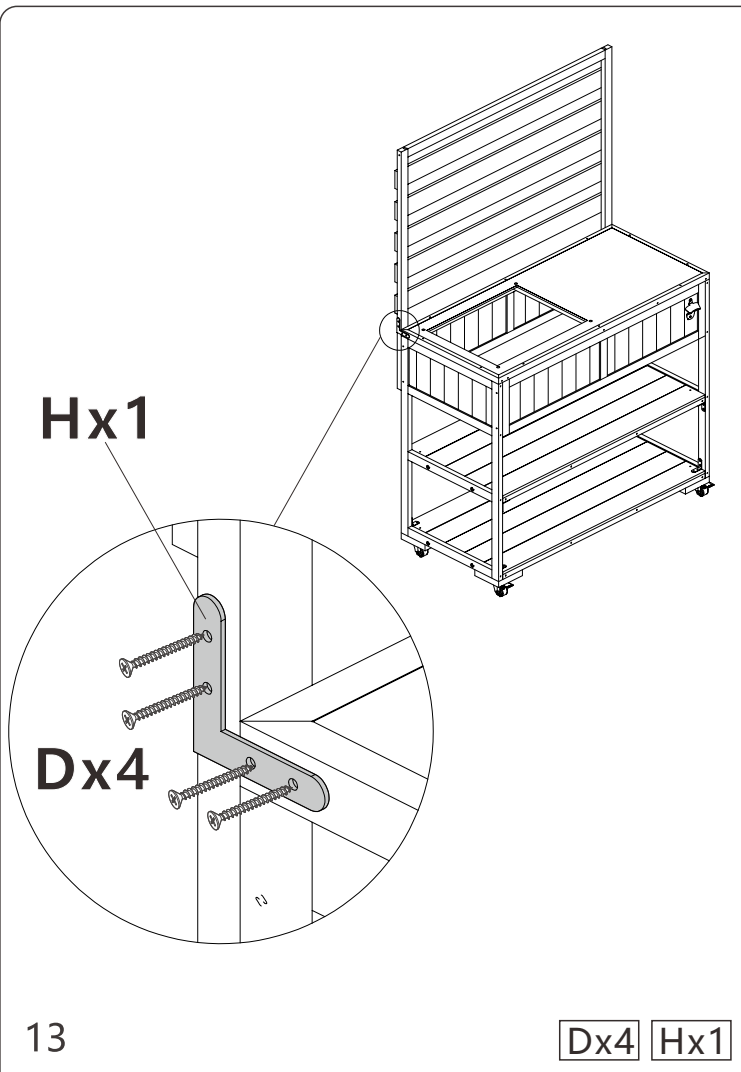

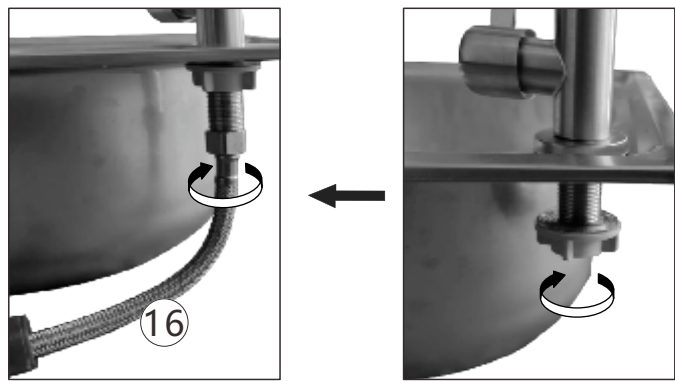
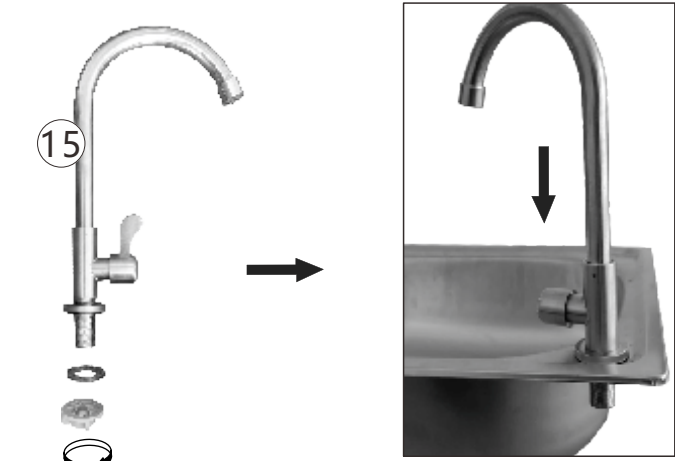

17 (15) x1 (16) x1

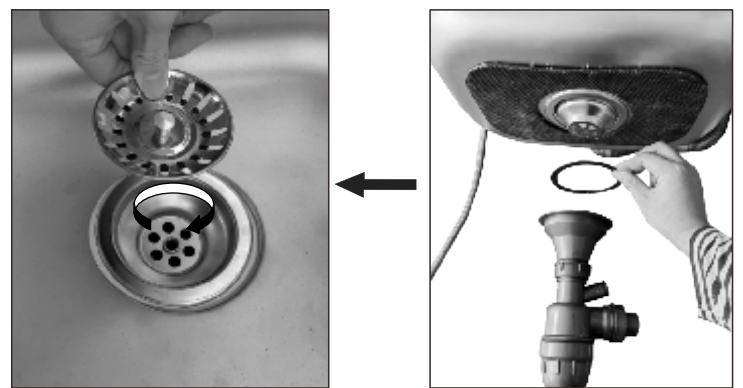
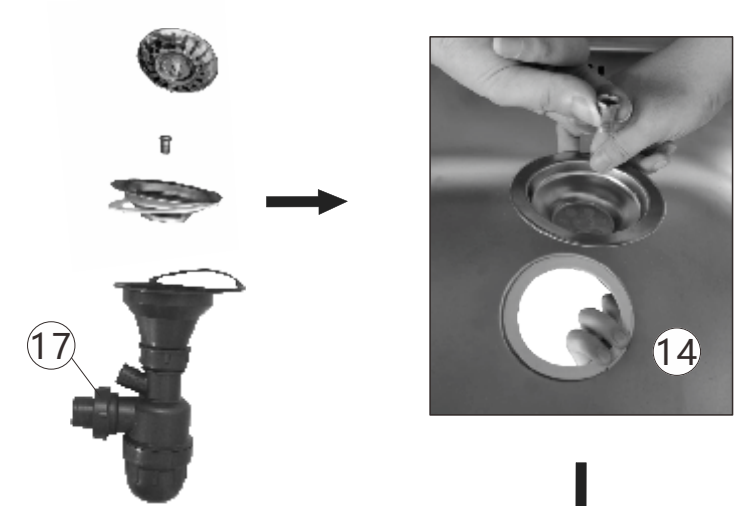

18 (14) x1 (17) x1

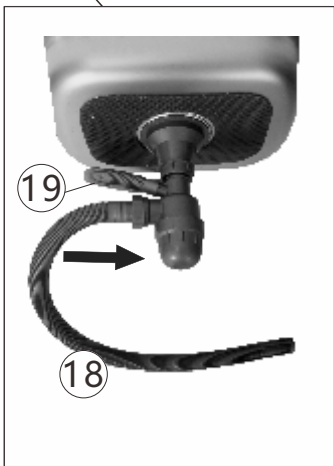

19 (18) x1 (19) x1

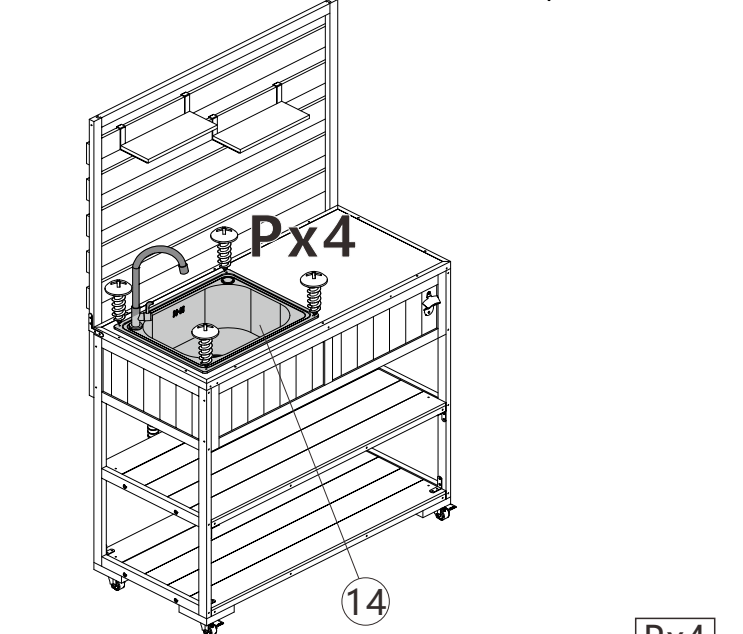
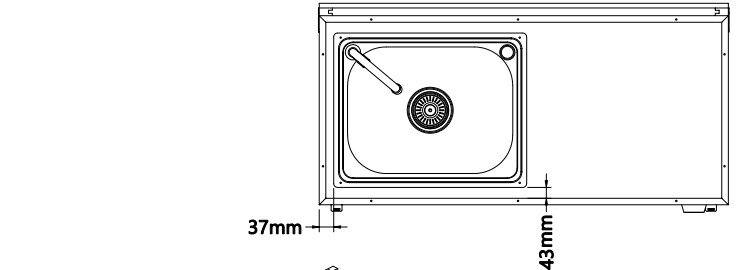

20 (Px4) (14) x1

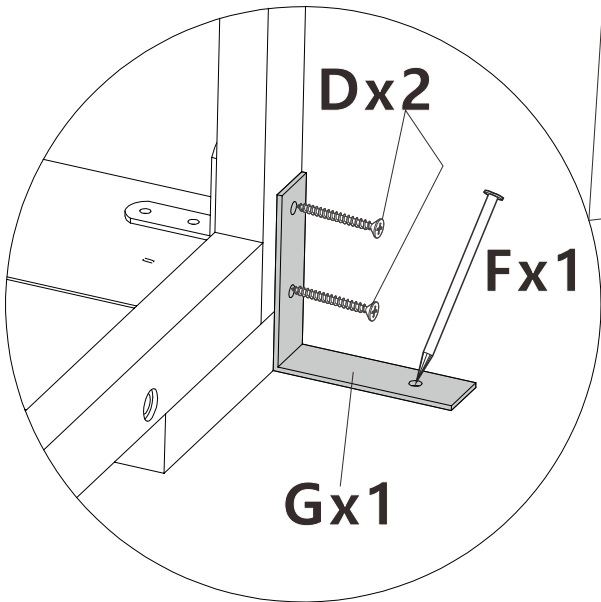
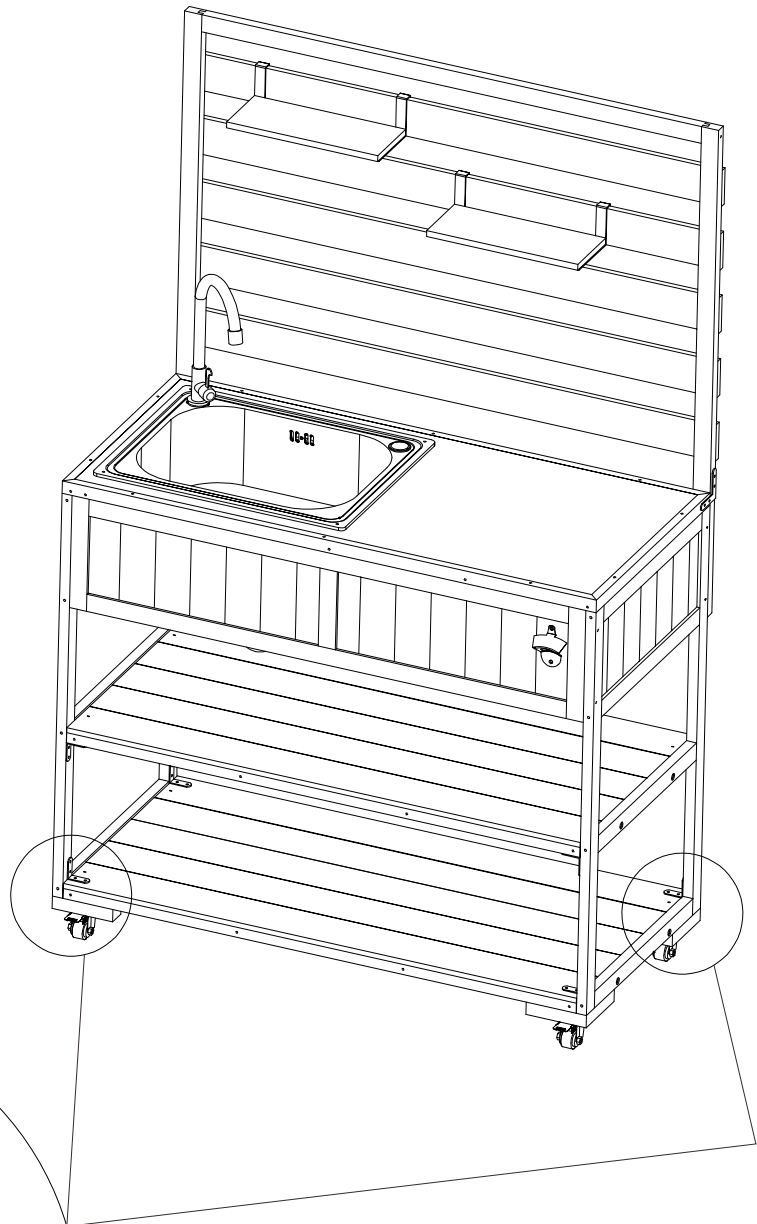

Remove 4 wheels firstly, then assembly L shape metal and nails.
 Retirez 4 roues tout d'abord, puis assemblage en forme de L métal et clous