

ASSEMBLY INSTRUCTIONS



SERVING CART

ASSEMBLY INSTRUCTIONS

ASSEMBLY TIPS:

1. Remove hardware from box and sort by size.
2. Please check to see that all hardware and parts are present prior to start of assembly.
3. Please follow attached instructions in the same sequence as numbered to assure fast & easy assembly.



WARNING!

1. Don't attempt to repair or modify parts that are broken or defective. Please contact the store immediately.
2. This product is for home use only and not intended for commercial establishments.

ASSEMBLY TIME

30 MINUTES

PARTS IDENTIFICATION

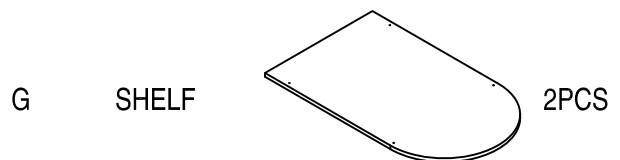
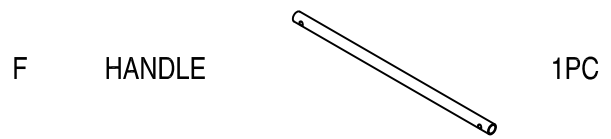
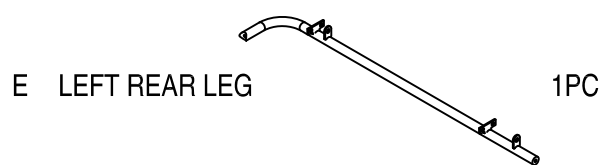
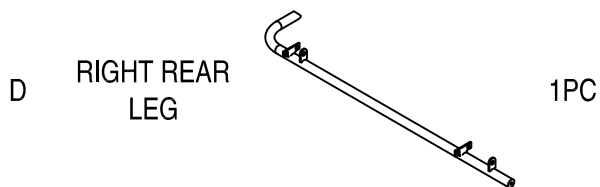
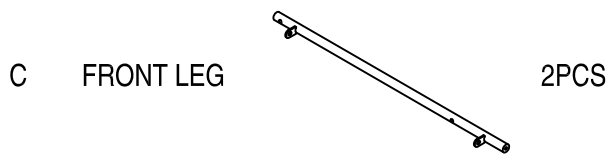
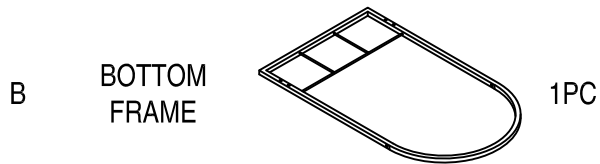
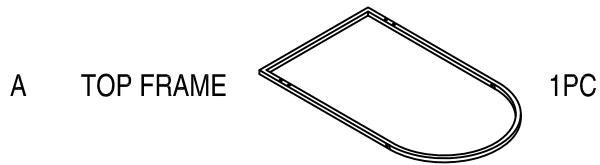









NOTE:

Phillips head screw driver is required in the assembly process; however, manufacturer does not provide this item.

ASSEMBLY INSTRUCTIONS

Z

HARDWARE IDENTIFICATION

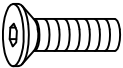
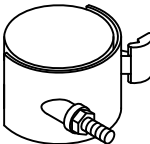
1	ALLEN WRENCH (4mm)		1PC	6	SCREW (Ø4mm x 9mm)		8PCS
2	WRENCH		1PC	7	CAP (Ø3/4")		4PCS
3	BOLT (Ø1/4" x 50mm)		2PCS	8	WASHER		4PCS
4	BOLT (Ø1/4" x 12mm)		8PCS	9	CASTER		2PCS
5	BOLT (Ø1/4" x 25mm)		4PCS	10	CASTER WITH LOCK		2PCS

NOTE:

Phillips head screw driver is required in the assembly process; however, manufacturer does not provide this item.

ASSEMBLY INSTRUCTIONS

STEP 1

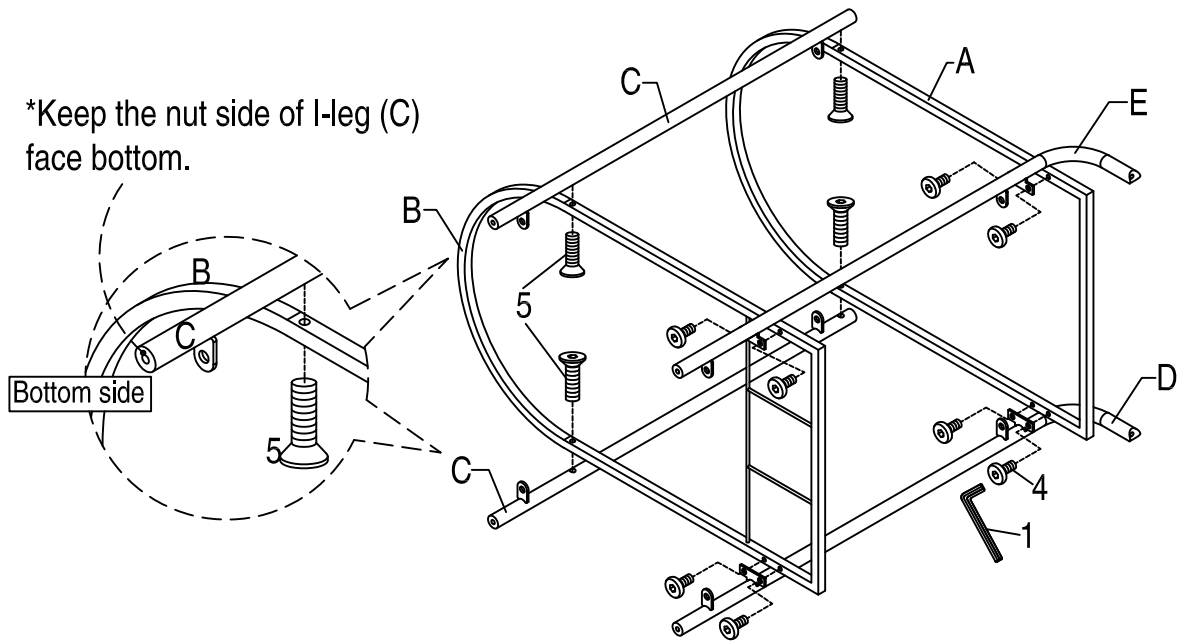

STEP 2

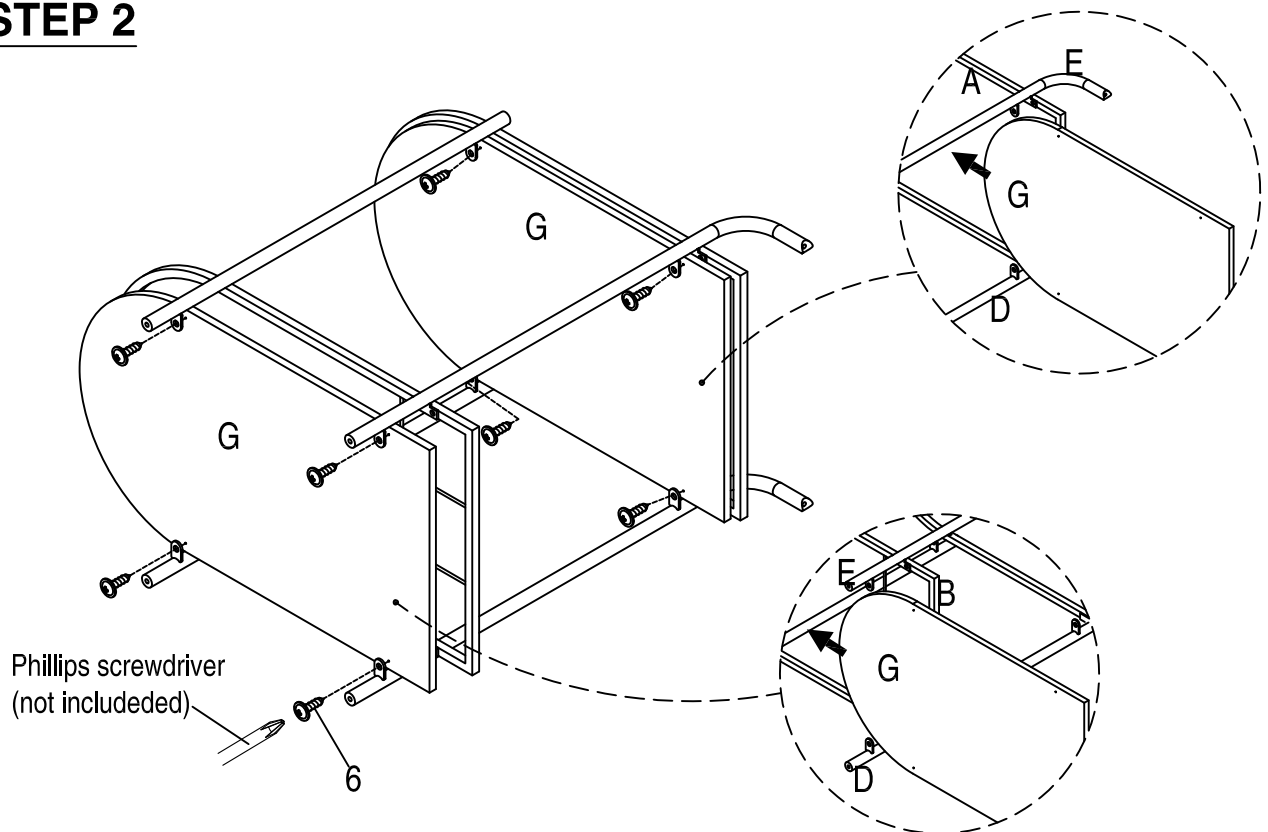

ASSEMBLY INSTRUCTIONS

STEP 3

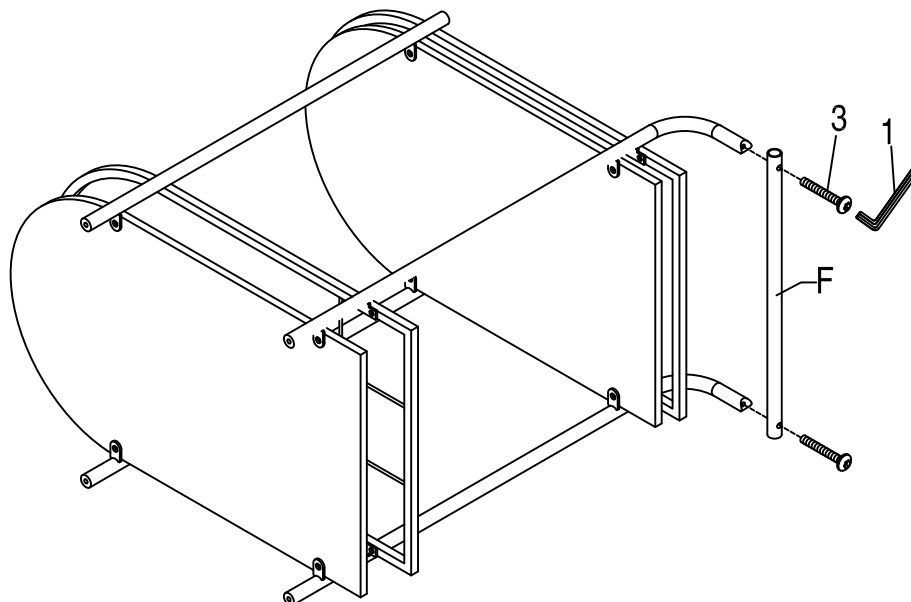

STEP 4

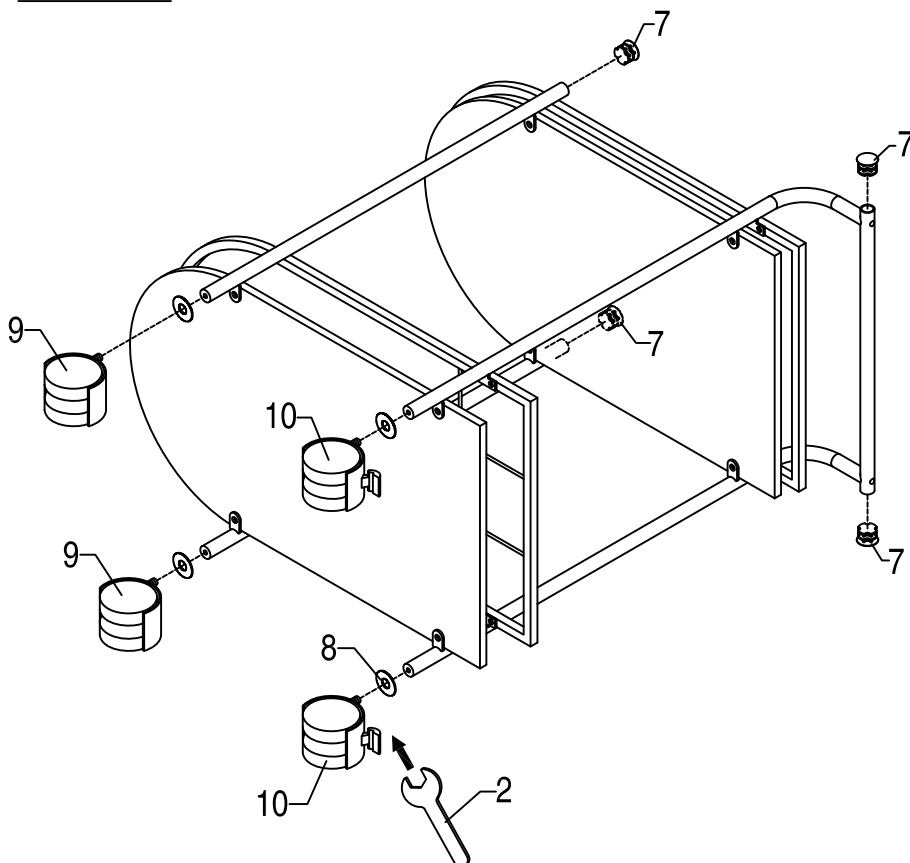

COMPLETE

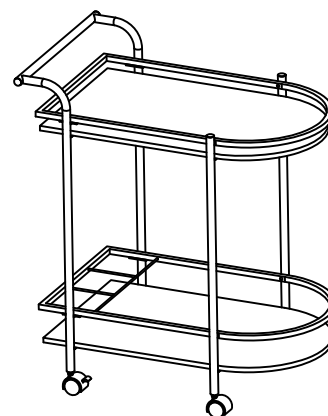

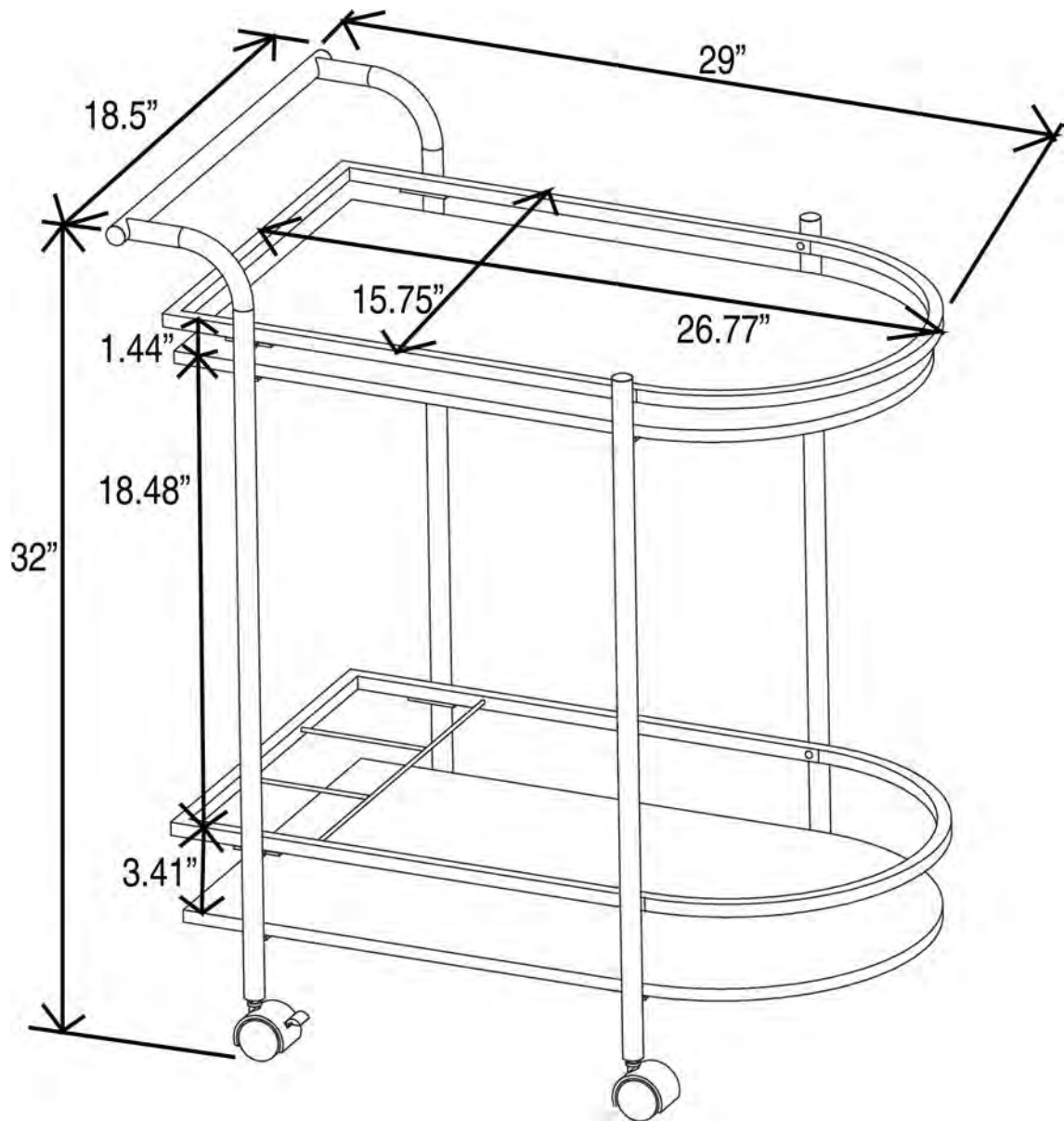

NOTE: Dimension tolerance $\pm 5\%$