

Manuale di Montaggio
Assembly Instructions

SC-CLO01

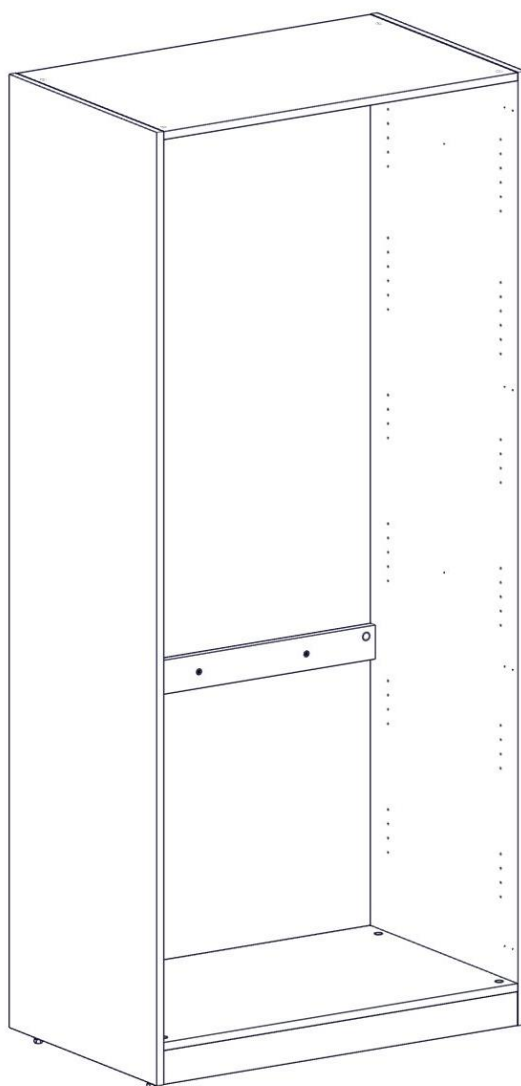

Immagini a scopo puramente illustrativo
Images merely illustrative

ISTRUZIONI DI MONTAGGIO ASSEMBLY INSTRUCTIONS

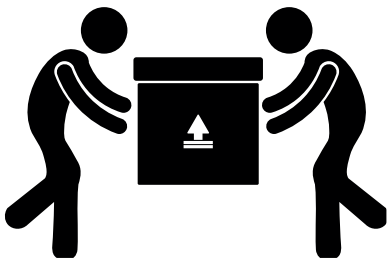

Per assemblarlo, sono necessarie 2 persone.

To assemble it, 2 people are required.

Strumenti necessari per l'assemblaggio.
Strumenti NON forniti.

Tools required for assembly.
Tools NOT provided.

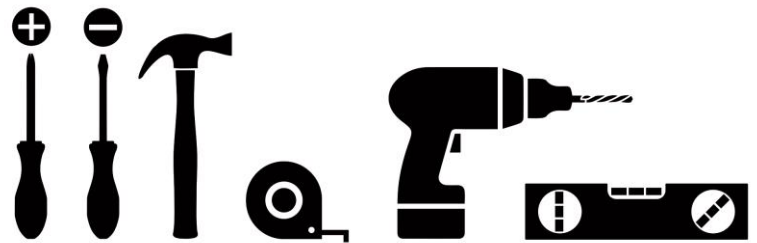

0-3

PERICOLO DI SOFFOCAMENTO - Questo prodotto contiene parti piccole. Tenere fuori dalla portata dei bambini.

CHOKING HAZARD - This product contains small parts. Keep out of reach of children.



La caduta dei mobili può causare lesioni **gravi** o **mortali**.

Fissare **SEMPRE** questo mobile alla parete con accessori di fissaggio.

NON permettere mai ai bambini di arrampicarsi o appendersi a cassetti, ante e ripiani.

Furniture tipping over can cause **serious** or **fatal** injuries.

ALWAYS secure this furniture to the wall with fixing accessories.

NEVER allow children to climb or hang on drawers, doors, or shelves.

ISTRUZIONI DI MONTAGGIO ASSEMBLY INSTRUCTIONS

Segui attentamente i passaggi di assemblaggio indicati nel manuale.

Follow the assembly steps carefully as indicated in the manual.



Prima di iniziare l'assemblaggio, identifica e separa tutte le parti e gli accessori.

Before starting the assembly, identify and separate all the parts and accessories.



Durante l'assemblaggio, tieni le parti e gli accessori organizzati per evitare incidenti.

During assembly, keep parts and accessories organized to avoid accidents.



Per proteggere i tuoi mobili, assemblalo su una superficie **pulita e piana**.

Suggerimento: Puoi utilizzare l'imballaggio del prodotto per foderare l'area dove verrà effettuato l'assemblaggio.

To protect your furniture, assemble it on a **clean and flat** surface.

Tip: You can use the product packaging to line the area where the assembly will be done.



PEZZI - PARTS

QTD.	CÓDIGO / CODE	DESCRIÇÃO	DESCRIZIONE	DESCRIPTION	C x L x E	L x W x T
1	P107432	LATERAL ESQUERDA	FIANCO SINISTRO	LEFT SIDE	2135 x 587 x 18 mm	84.06 x 23.11 x 0.71 in
2	P107433	BASE / CHAPÉU	FONDO / CIELO	BASE / HAT	915 x 586 x 18 mm	36.02 x 23.07 x 0.71 in
1	P107434	LATERAL DIREITA	FIANCO DESTRO	RIGHT SIDE	2135 x 587 x 18 mm	84.06 x 23.11 x 0.71 in
2	P107436	SARRAFO	CATENA	SLAT	915 x 76 x 18 mm	36.02 x 2.99 x 0.71 in
2	P107603	RODAPÉ	BATTISCOPA	BASEBOARD	915 x 76 x 18 mm	36.02 x 2.99 x 0.71 in

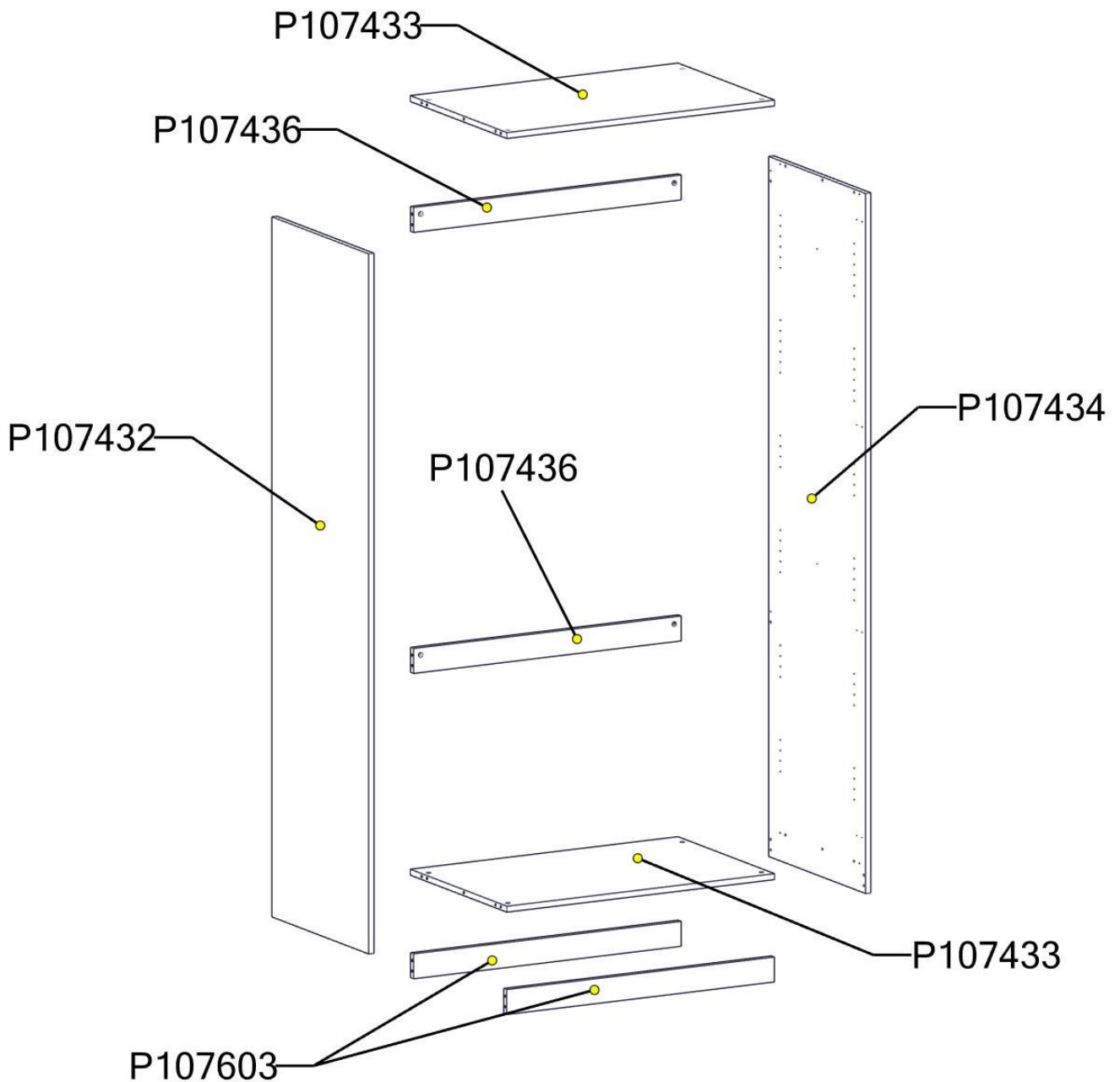

ACCESSORI - ACCESSORIES



In caso di dubbio sulla dimensione delle viti, puoi utilizzare il righello illustrato qui sotto per verificare la misura esatta.

In case of doubt about the screw size, you can use the ruler illustrated below to check the exact measurement.

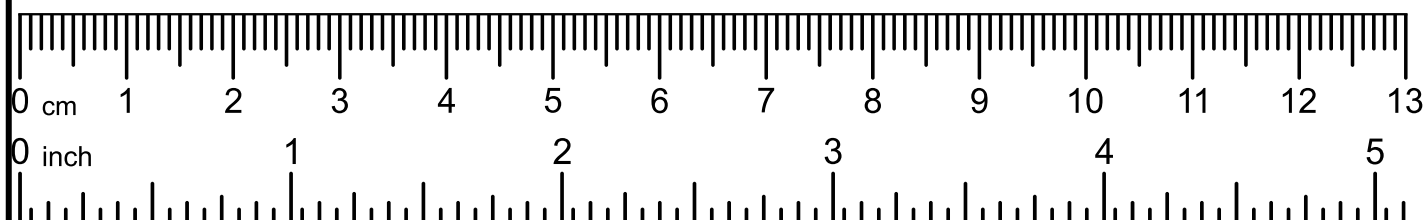
	QTD.	CÓDIGO / CODE	DESCRIÇÃO	DESCRIZIONE	DESCRIPTION
	24	001776	CAVILHA DE MADEIRA 8X30MM	PERNO DI LEGNO 8X30MM	DOWEL 8X30MM
	6	008373	P.CHATO 5,0 X 70MM	VITE 5,0 X 70MM	SCREW 5,0 X 70MM
	6	010745	BUCHA NYLON	TASSELLO IN NYLON	NYLON FIXING BUSHING
	12	030945	PARAFUSO P/ MINIFIX	DADO MINIFIX	MINIFIX DOWEL
	12	030950	TAMBOR P/ MINIFIX 15MM	CAMME MINIFIX 15MM	MINIFIX CAM 15MM
	4	077914	BUCHA ROSCA 1/4	BUSSOLA FILETTATA 1/4	THREAD BUSHING 1/4
	4	077915	SAPATA REGULÁVEL 1/4X25	PIEDINO REGOLABILE 1/4X25	ADJUSTABLE FOOT 1/4X25
	1	080586	CHAVE BOCA 5/8	CHIAVE FISSA 5/8	WRENCH 5/8
	4	084605	P. MAQUINA CHATO M4 X 16MM CAB. PHILLIPS	VITE M4 X 16MM	SCREW M4 X 16MM
	4	091116	FEMEA PF. UNIÃO 5 X 27MM - ROSCA M4	DADO CILINDRICO 5 X 27MM	BARREL NUT 5 X 27MM



ACCESSORI - ACCESSORIES

	6	13MM	TAPA FURO	TAPPO COPRIFORO	SCREW CAP COVER
	12	19MM	TAPA FURO	TAPPO COPRIFORO	SCREW CAP COVER
	2 (KIT)	KIT 5MM	TAPA FURO	TAPPO COPRIFORO	SCREW CAP COVER

INSTALLAZIONE DEL SET MINIFIX INSTALLATION OF THE MINIFIX SET

INSERIMENTO DELLA CAMMA

Identifica la freccia sulla testa della camma. La freccia DEVE essere rivolta verso il foro nel bordo del pannello. Spingi la camma completamente nel foro.

INSERTING THE CAM

Identify arrow on head of cam. Arrow MUST point toward hole in edge of panel. Push cam all the way down into hole.

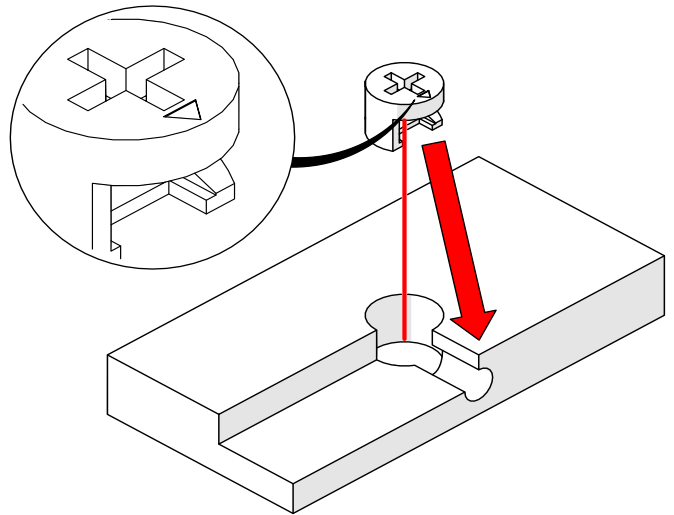

ALLINEAMENTO DELLA CAMMA E DEL DADO

Assicurati che la freccia sulla camma punti verso il foro e inserisci il dado della camma nel foro. Verifica che i pezzi si uniscano correttamente.

CAM AND DOWEL ALIGNMENT

Ensure the arrow on the cam points toward hole and insert cam dowel into hole. Make sure pieces join together.

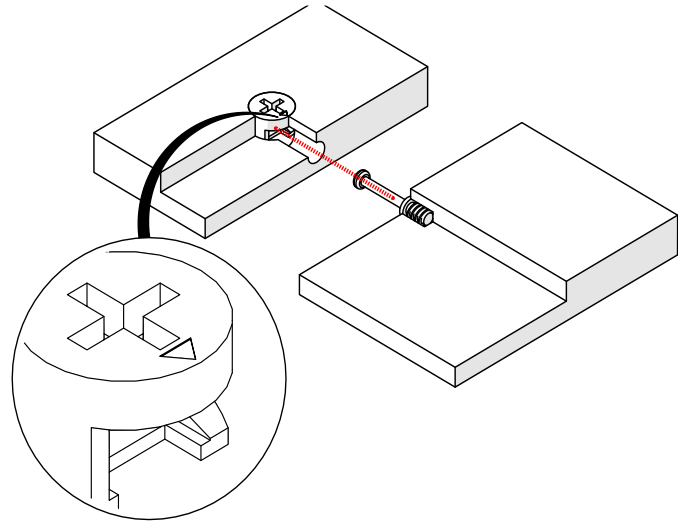

FISSAGGIO DELLA CAMMA

Usa un cacciavite per girare la camma. Gira la camma [in senso orario] fino a quando non è completamente fissata. Un po' più di mezza rotazione.

TIGHTENING CAM

Use screwdriver to turn cam. Turn cam [clockwise] until fully tightened. Slightly more than half a turn.

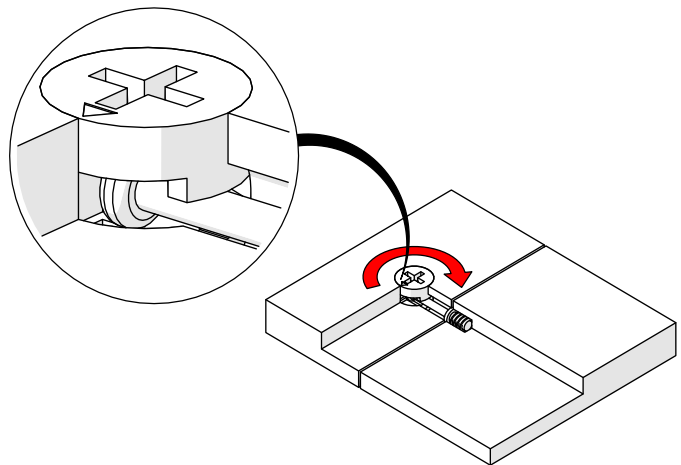

PASSO 1 / STEP 1

Cód.	Qtde.
030945	6

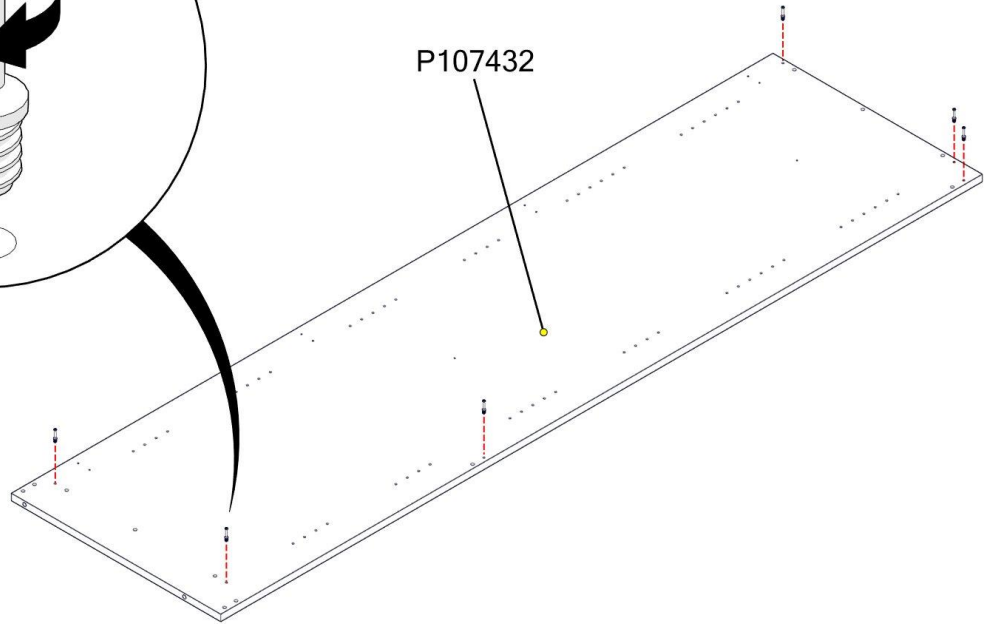
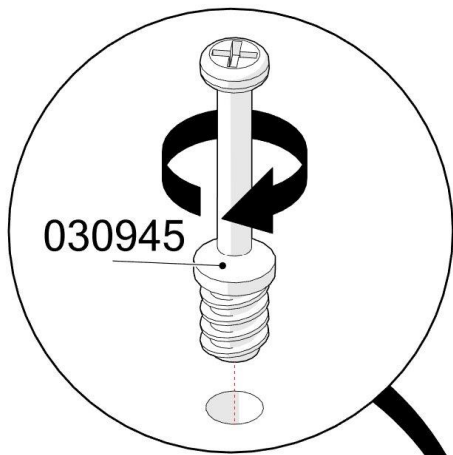

PASSO 2 / STEP 2

Cód.	Qtde.
077914	2
077915	2

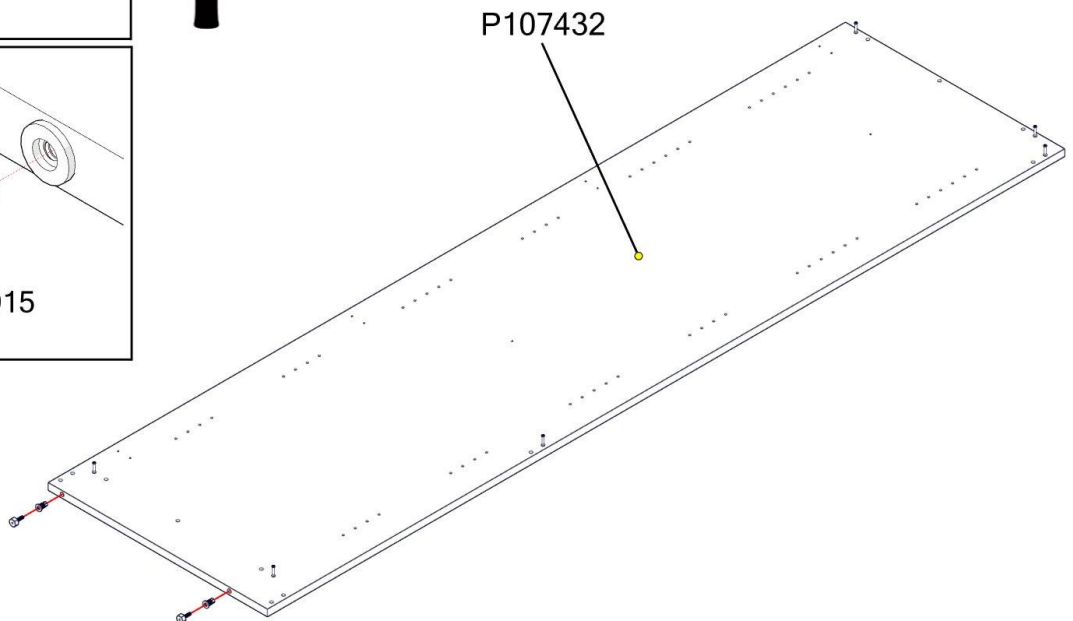
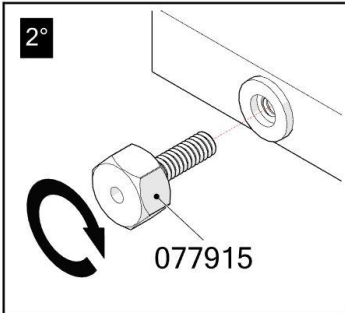
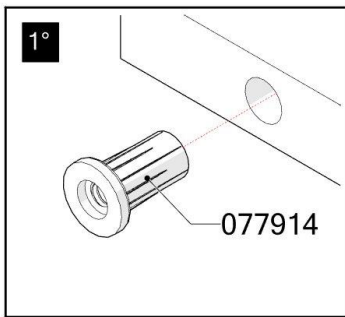

PASSO 3 / STEP 3

Cód.	Qtde.
030945	6

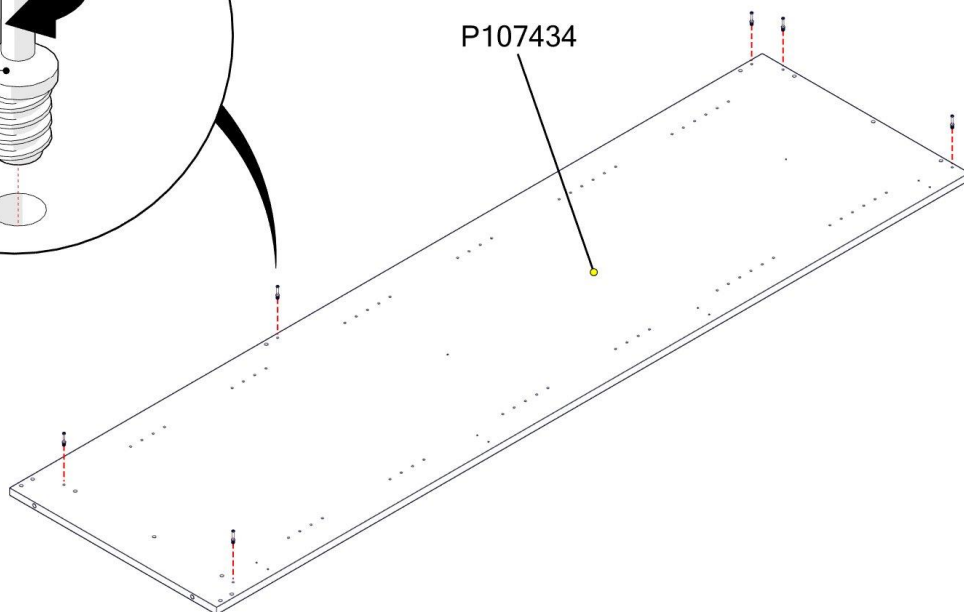
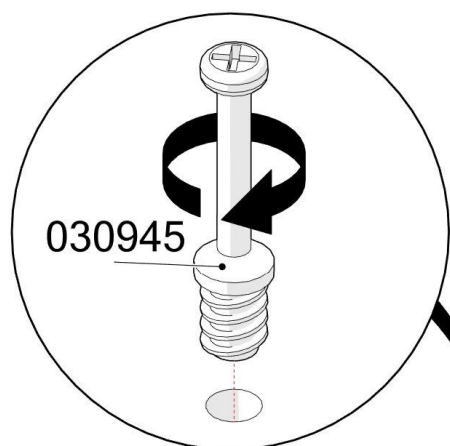

PASSO 4 / STEP 4

Cód.	Qtde.
077914	2
077915	2

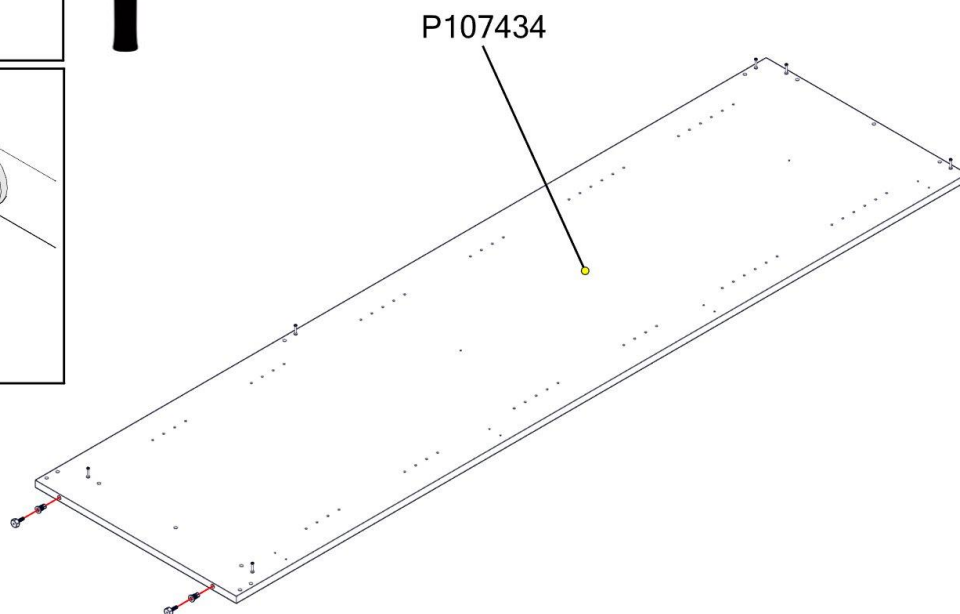
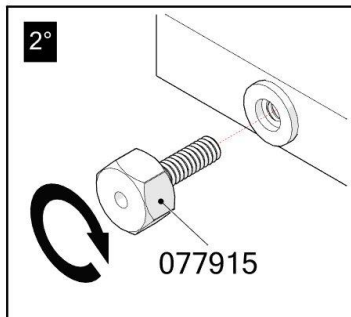
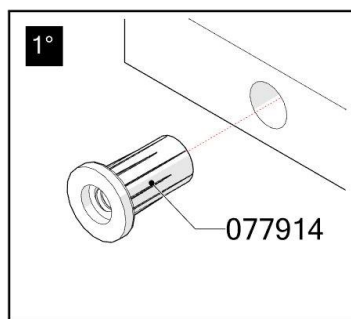

PASSO 5 / STEP 5

Cód.	Qtde.
001776	12

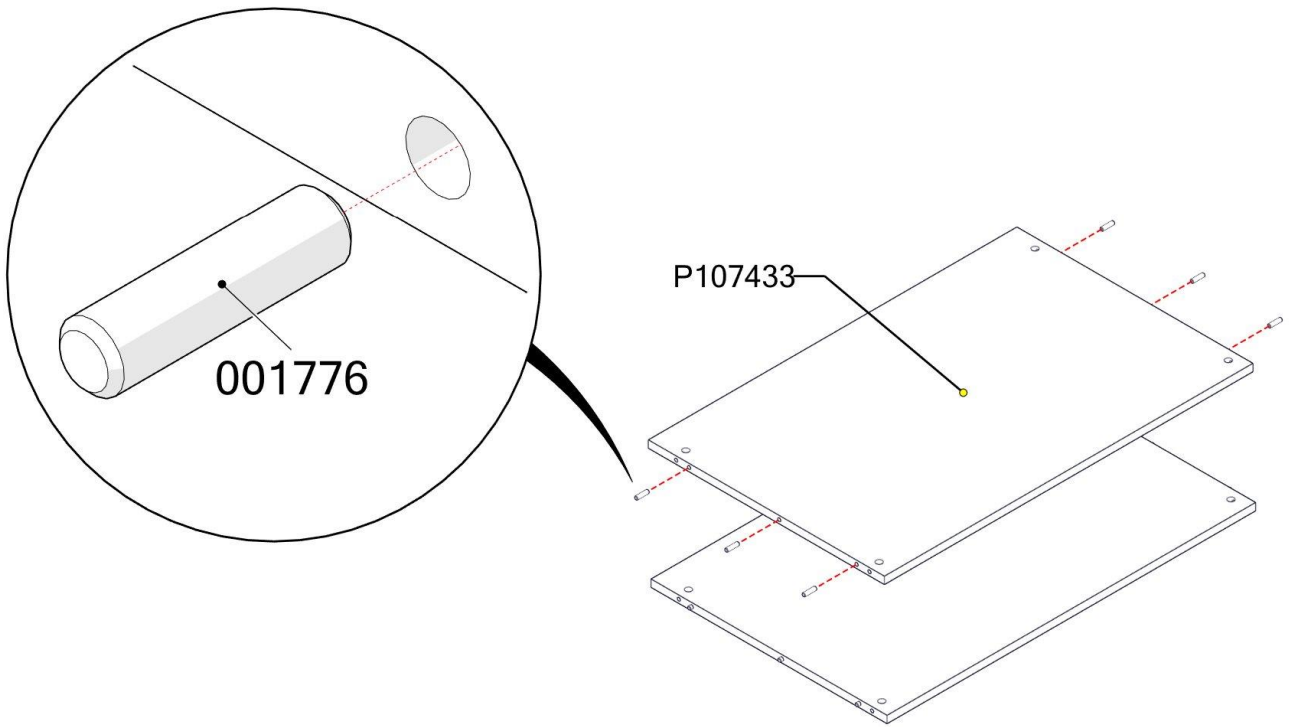

PASSO 6 / STEP 6

Cód.	Qtde.
001776	4

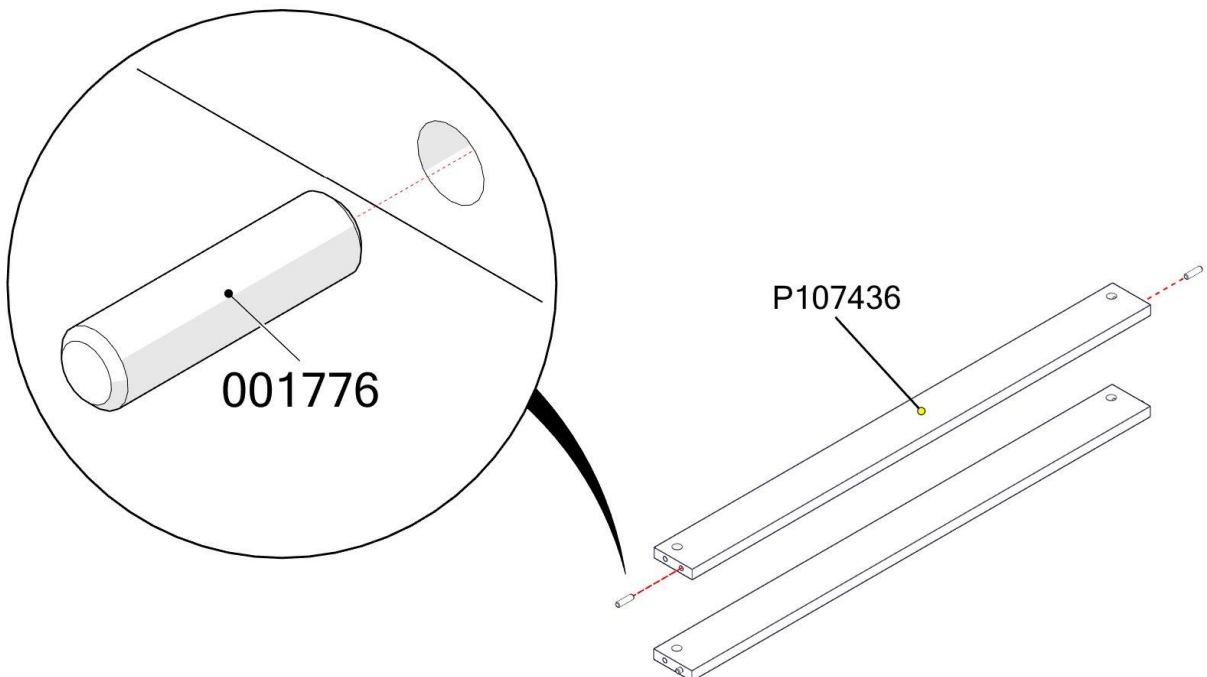

PASSO 7 / STEP 7

Cód.	Qtde.
001776	8

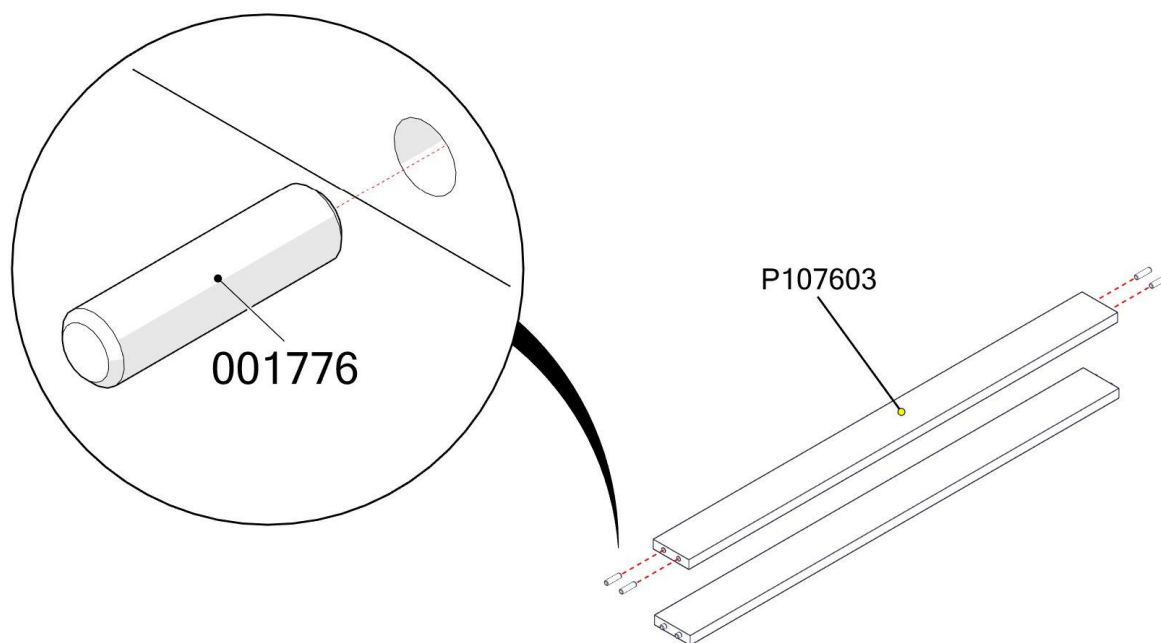

PASSO 8 / STEP 8

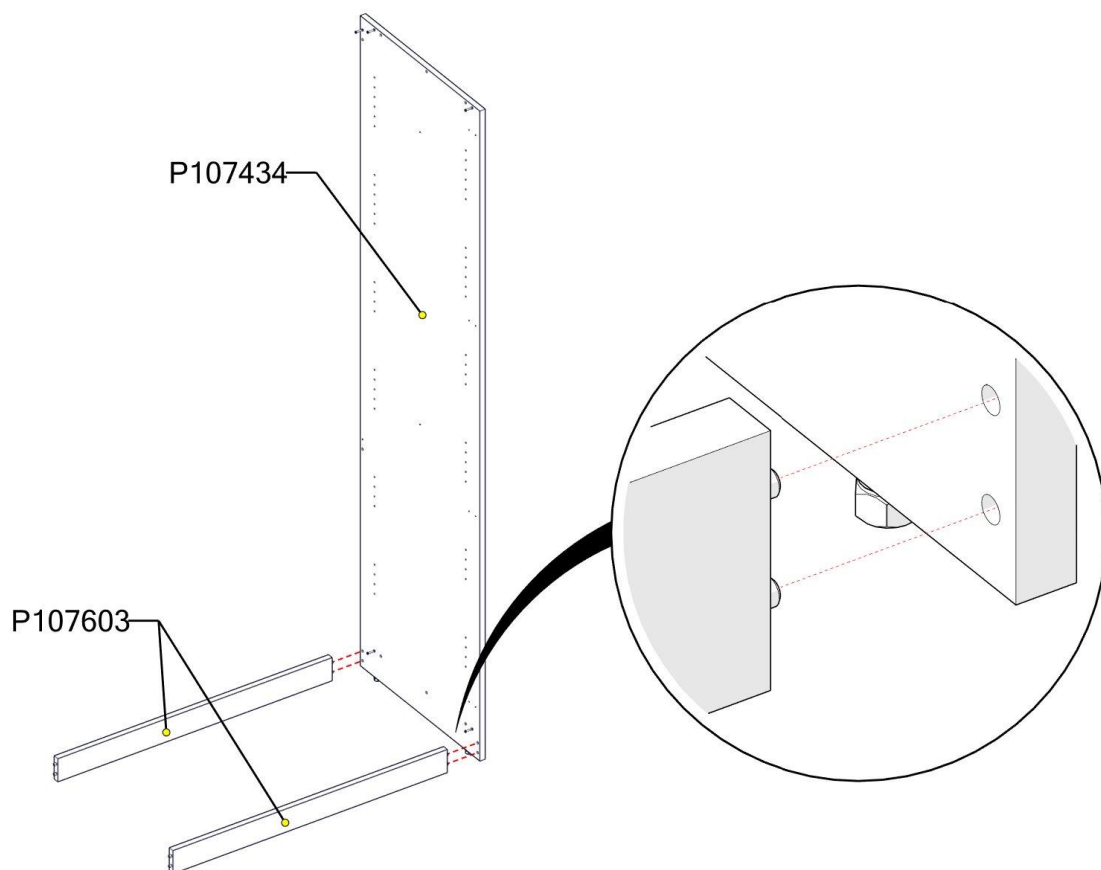
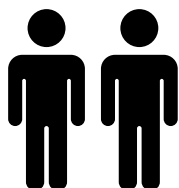

PASSO 9 / STEP 9

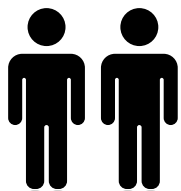

Cód.	Qtde.
030950	2

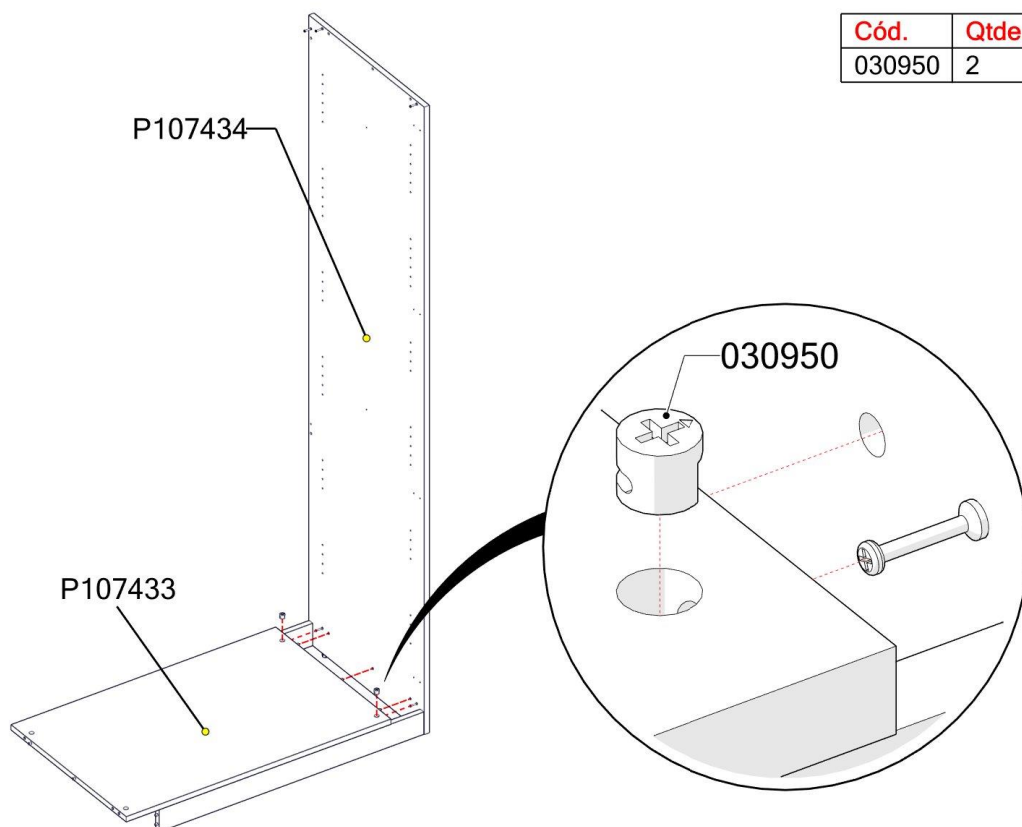

PASSO 10 / STEP 10

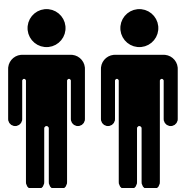

Cód.	Qtde.
030950	2

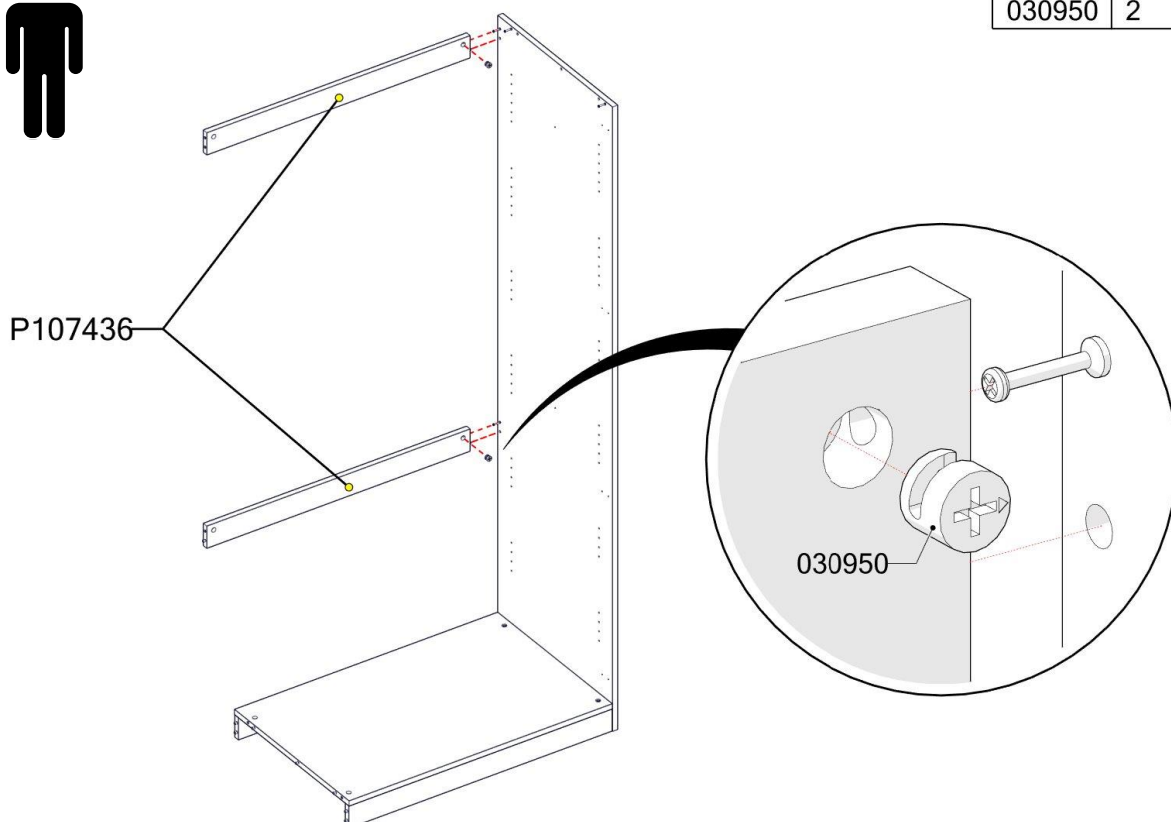

PASSO 11 / STEP 11

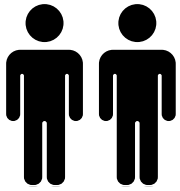

P107433

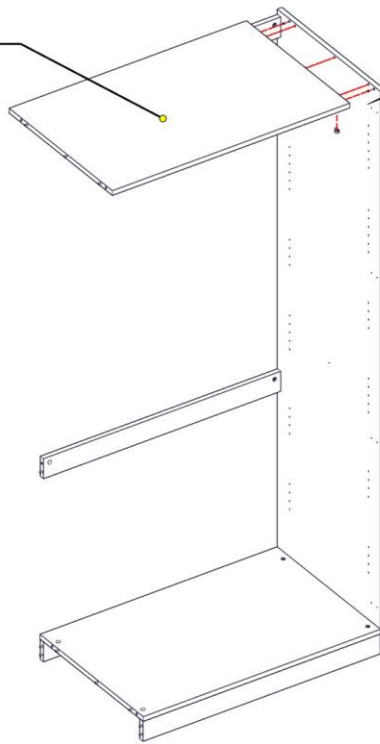

Cód.	Qtde.
030950	2

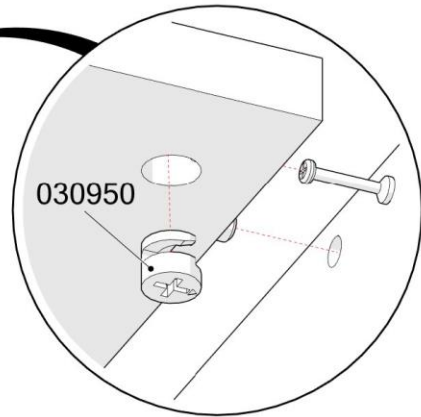

PASSO 12 / STEP 12

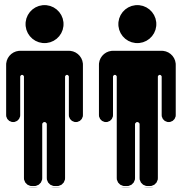

Cód.	Qtde.
030950	6

P107432

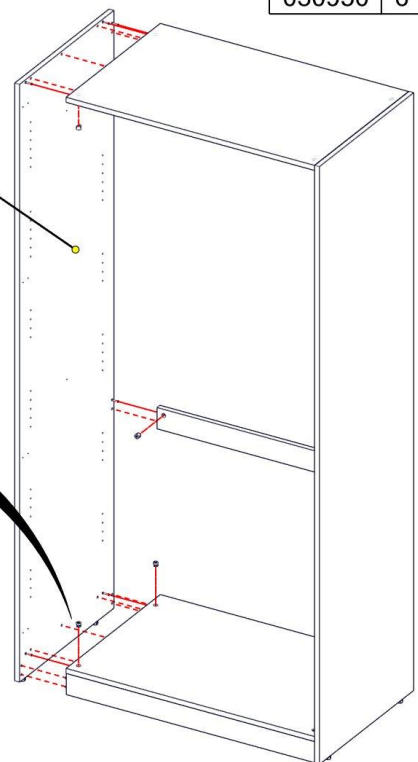
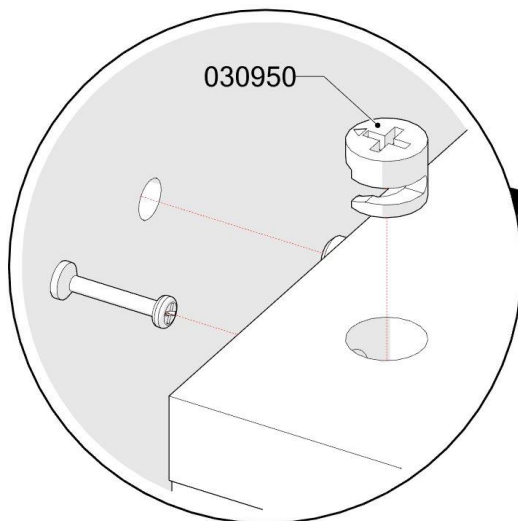

PASSO 13 / STEP 13

Cód.	Qtde.
080586	1

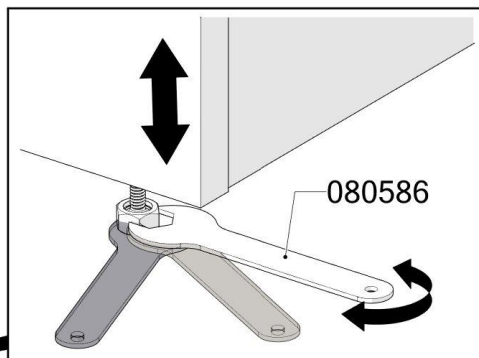
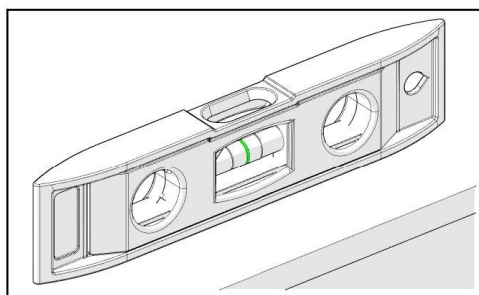
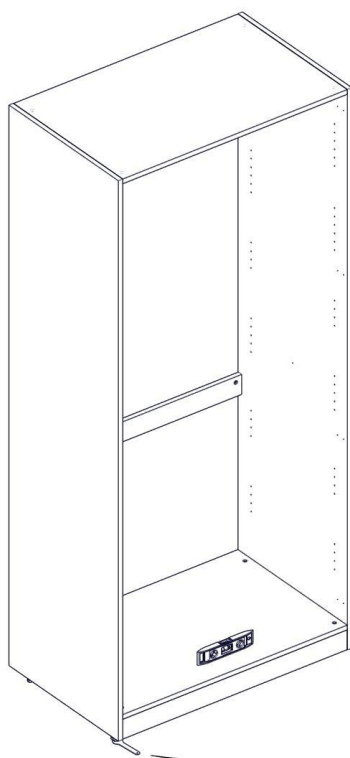

FISSAGGIO SU PARETE WALL MOUNTING



La caduta dei mobili può causare lesioni **gravi** o **mortali**.

Fissare **SEMPRE** questo mobile alla parete con accessori di fissaggio.

NON permettere mai ai bambini di arrampicarsi o appendersi a cassetti, ante e ripiani.

Furniture tipping over can cause **serious** or **fatal** injuries.

ALWAYS secure this furniture to the wall with fixing accessories.

NEVER allow children to climb or hang on drawers, doors, or shelves.

FISSAGGIO SU PARETE WALL MOUNTING

Le viti e i tasselli forniti possono essere utilizzati su pareti solide [come il mattone] e pareti vuote [come il cartongesso].

Per pareti in legno massiccio, utilizzare solo la vite.

In caso di dubbi, consultare un professionista.

The supplied screws and wall plugs can be used on solid walls [such as brick] and hollow walls [such as drywall].

For solid wood walls, use only the screw.

If in doubt, consult a professional.

Muri solidi [come i mattoni]
Solid walls [like bricks]

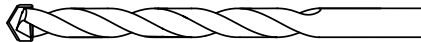
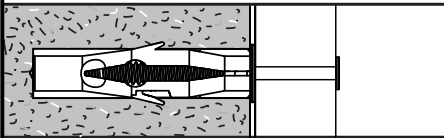

Ø8mm [5/16"]

Muri cavi [come il gesso]
Hollow walls [like drywall]

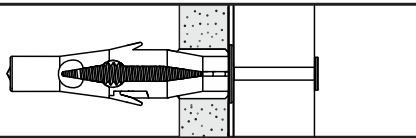

Ø8mm [5/16"]

Muri in legno massiccio
Solid wood walls

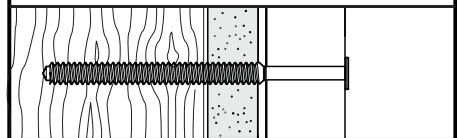

Ø3mm [1/8"]

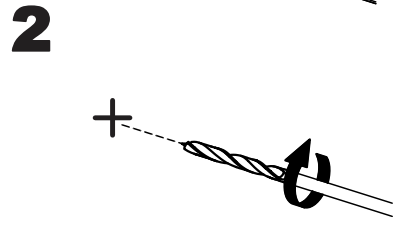
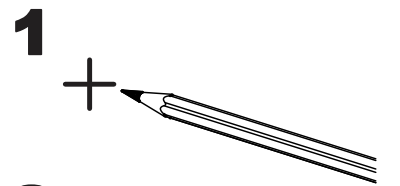
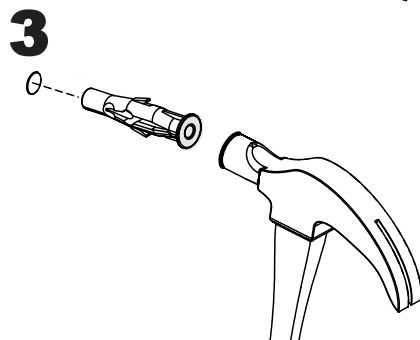
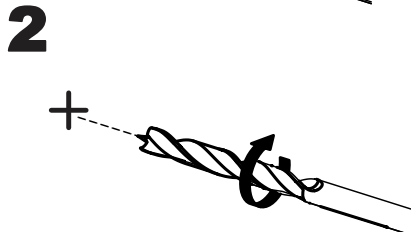
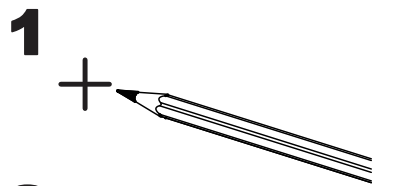
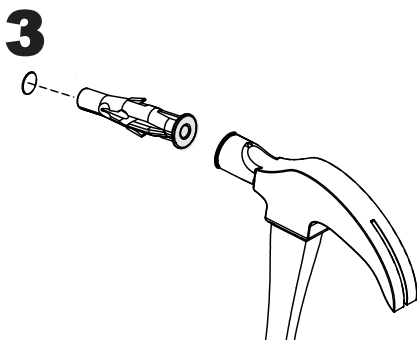
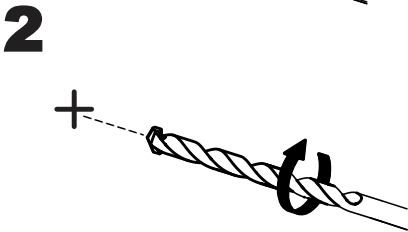
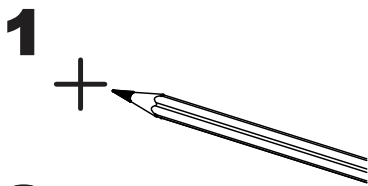

PASSO 14 / STEP 14

Cód.	Qtde.
008373	6
010745	6

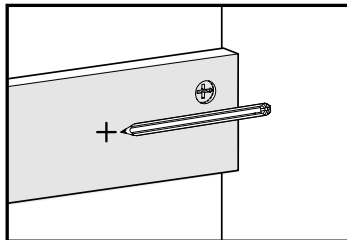
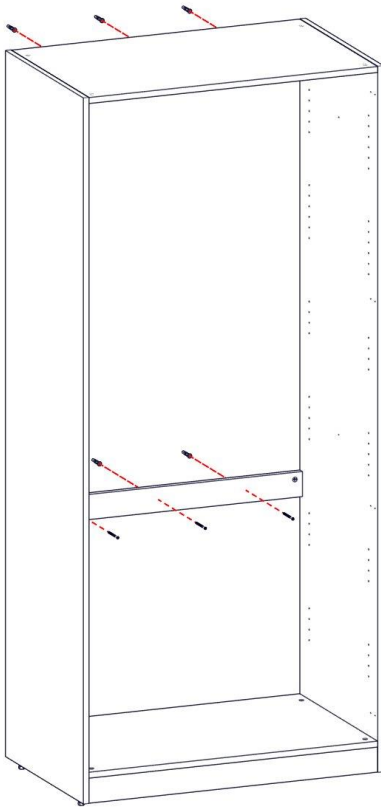

Segna le posizioni dove il mobile e la parete verranno forati.

Mark the positions where the furniture and the wall will be drilled.

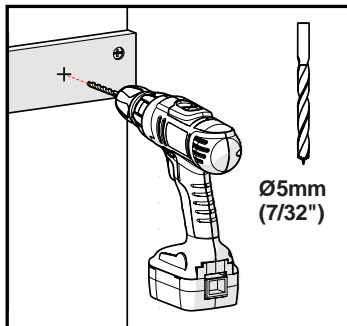

Utilizzando una punta da 5mm [7/32"], perfora il mobile secondo le marcature fatte.

Using a 5mm [7/32"] drill bit, drill the furniture according to the markings made.

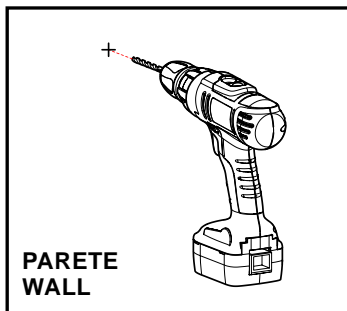

Perforare la parete utilizzando la punta adatta per il tipo di materiale.

In caso di dubbio, torna indietro di una pagina.

Drill the wall using the appropriate drill bit for the material type.

If in doubt, go back one page.

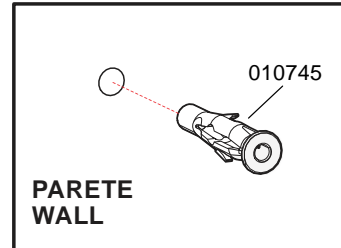

Inserisci i tasselli nei fori fatti nella parete.

Insert the anchors into the holes made in the wall.

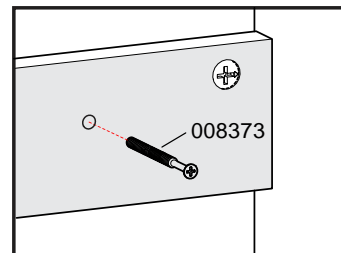

Fissa il mobile alla parete.

Secure the furniture to the wall.

PASSO 15 / STEP 15

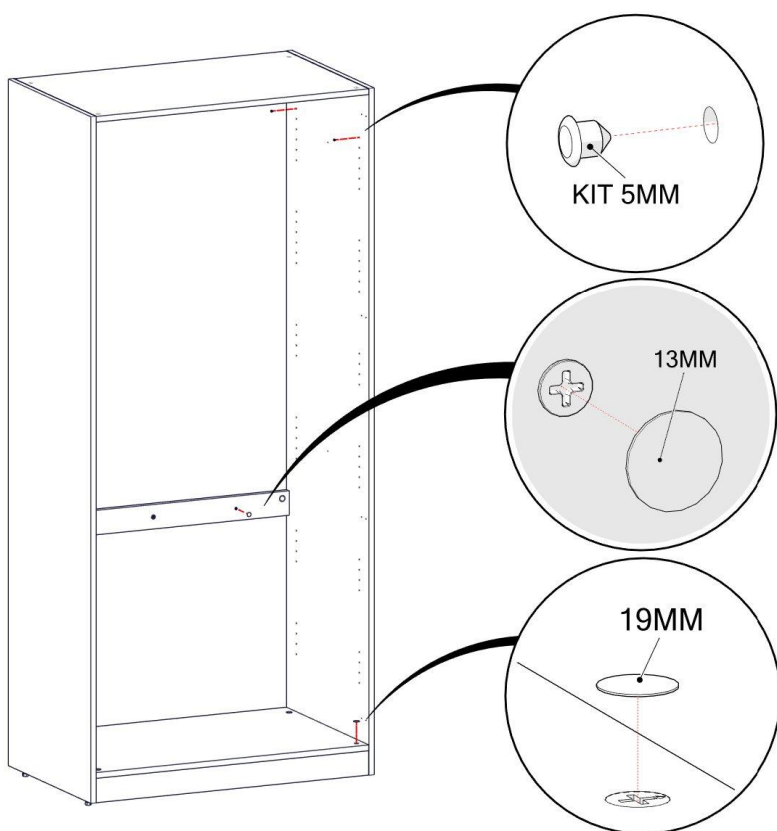

Cód.	Qtde.
KIT 5MM	2
13MM	6
19MM	12

PASSO 16 / STEP 16

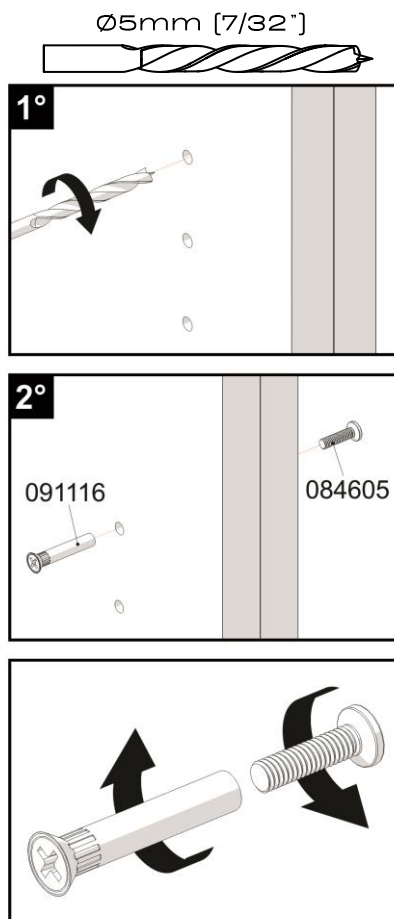
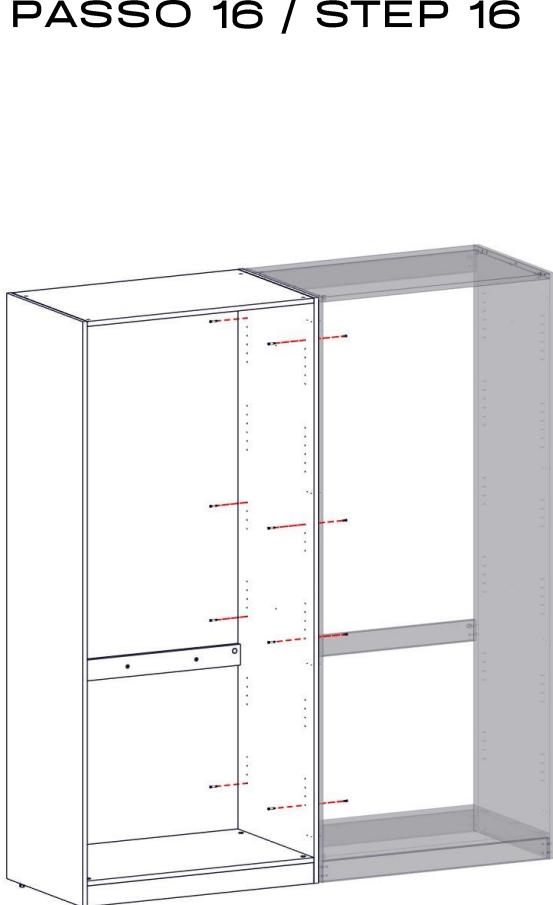

Cód.	Qtde.
084605	4
091116	4

Ogni modulo è dotato di 4 kit. In totale ci sono 8 kit per unire due moduli.

Each module comes with 4 kits. In total there are 8 kits to join two modules.

Pulizia / Cleaning:

- Rimuovere la polvere con un panno asciutto.
- Utilizzare un panno morbido leggermente inumidito con acqua per pulire.
- Se necessario, utilizzare detergente o sapone neutro diluito in acqua.
- Non utilizzare prodotti abrasivi per evitare danni al mobile.

- Dust with a dry cloth.
- Use a soft cloth slightly dampened with water for cleaning.
- If necessary, use detergent or neutral soap diluted in water.
- Do not use abrasive products to avoid damaging the furniture.

Conservazione / Maintenance:

- Proteggi il mobile dall'umidità eccessiva.
- Evita l'esposizione diretta al sole o a fonti di calore.
- Non superare il peso massimo indicato per ripiani e cassetti.
- Serrare periodicamente le viti per mantenere la stabilità.
- Per spostare il mobile, sollevalo invece di trascinarlo.
- I mobili pesanti devono essere trasportati da due persone.

- Protect the furniture from excessive moisture.
- Avoid direct exposure to the Sun or heat sources.
- Do not exceed the maximum weight indicated for shelves and drawers.
- Tighten the screws periodically to maintain stability.
- To move the furniture, lift it instead of dragging it.
- Heavy furniture should be moved by two people.