

# Mid-Century Modern Sofa

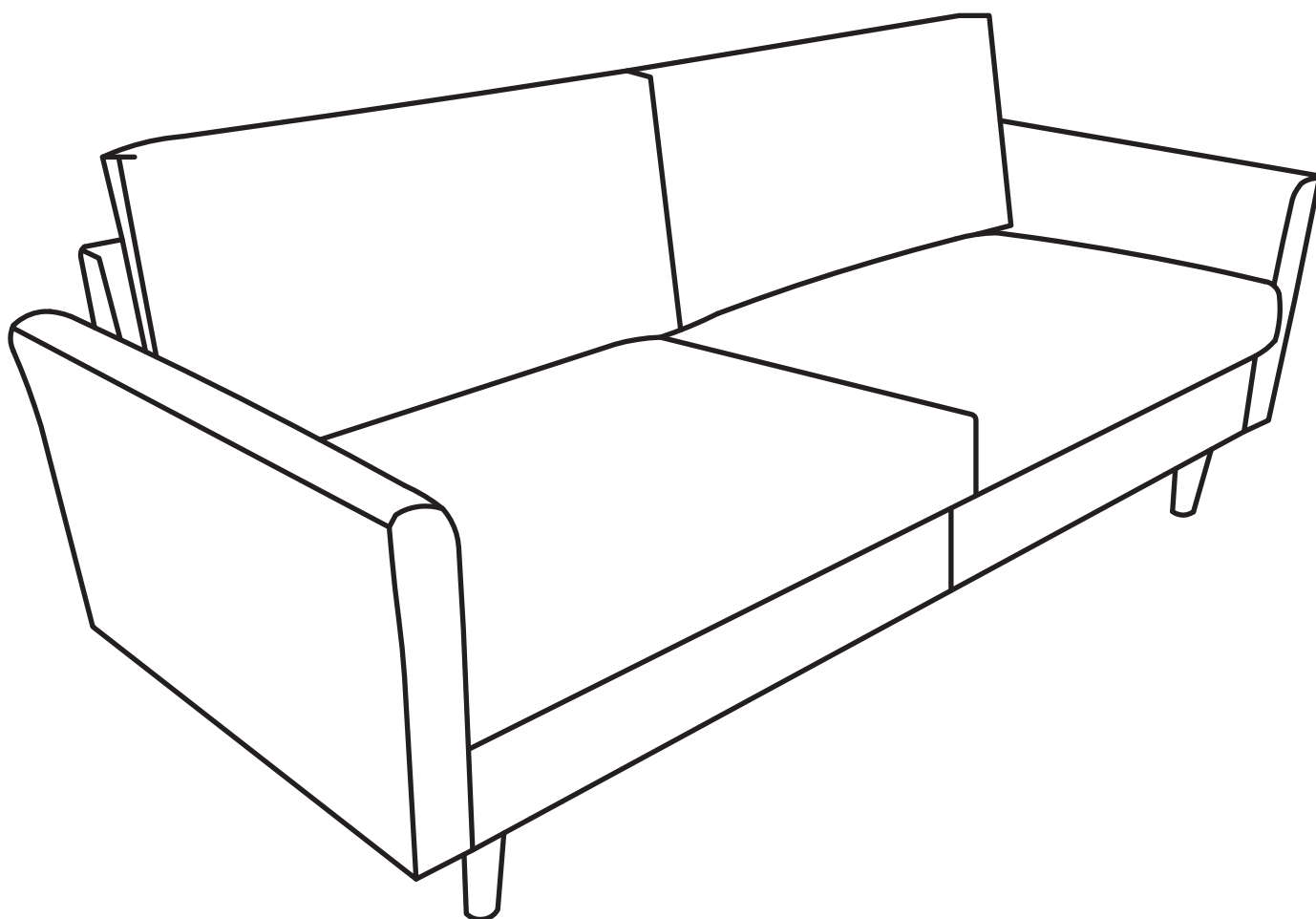

# Before you start...

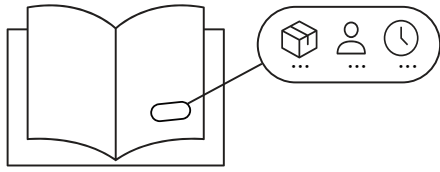

Ensure you familiarize yourself with the workload. Make sure there are enough helping hands to assist you, and that you have allocated the time required to assemble your new product.

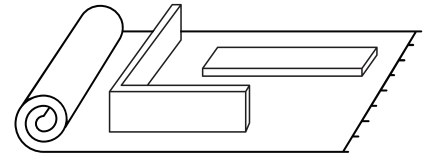

Make sure you have cleared enough space in your home for the assembly. We recommend protecting your floor with a mat or cardboard to avoid scratches during the assembly process.

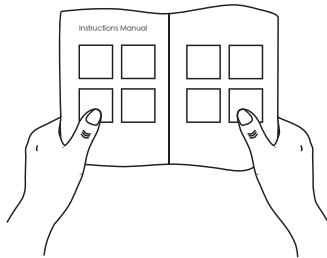

Read instructions carefully and check no parts are missing.

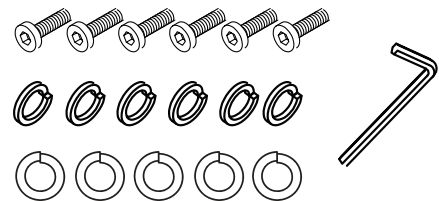

Lay out all hardware on a soft surface so you can easily identify them.

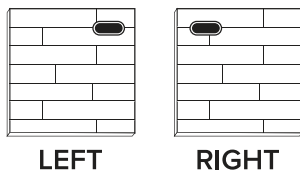

Carefully identify all components in order to differentiate which pieces are left and right.

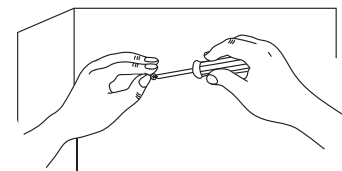

Install your new product carefully following the instructions. Don't skip ahead!

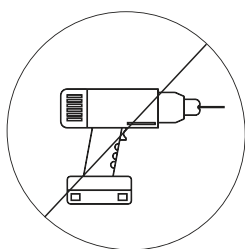









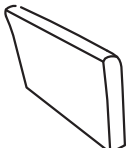

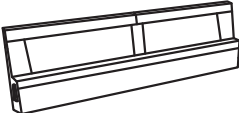
**DO NOT** over tighten screws or use a drill. It will damage the product.



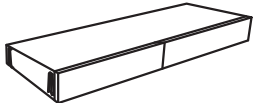

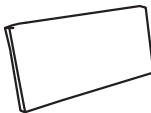
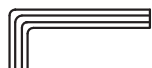
If you need further assistance with assembling your product.

# Parts

	Ax2		Fx3
	Bx1		Gx2
	Cx2		Hx8
	Dx1		Ix8
	Ex2		Jx1
			Kx3

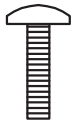
# Hardware

<input type="checkbox"/>		Bolt M10*45mm Hx8
<input type="checkbox"/>		Allen Key Ix8
<input type="checkbox"/>		Metal Plate Jx1
<input type="checkbox"/>		Kx3



There are inner box(es) that include components required to complete this assembly.



Please do not completely tighten all the hardware, until the entire assembly is complete.



Before discarding the packaging, please use the checklist to ensure that you have all the parts required to assemble your product. Please kindly note you will need the original package if you want to return the product later.



If parts are missing or damaged, we will gladly ship your replacements parts free of charge.



x1



x2



20mins

# Step 1

Connect the two sofa seats using Leg G and secure it by 8 bolts

Screw the gasket K and leg F into each corner of the sofa, but do not overtighten them.

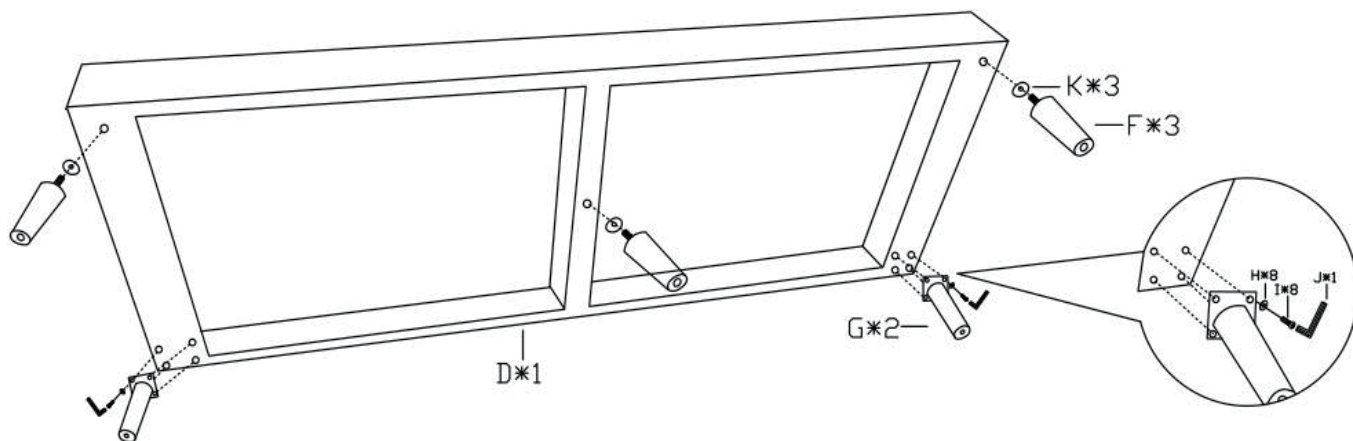

# Step 2

Gently place the bottom plate D that has already installed the sofa leg on the ground

Install the arm rest by ensuring brackets are aligned and slide it all the way in to prevent any misalignment.

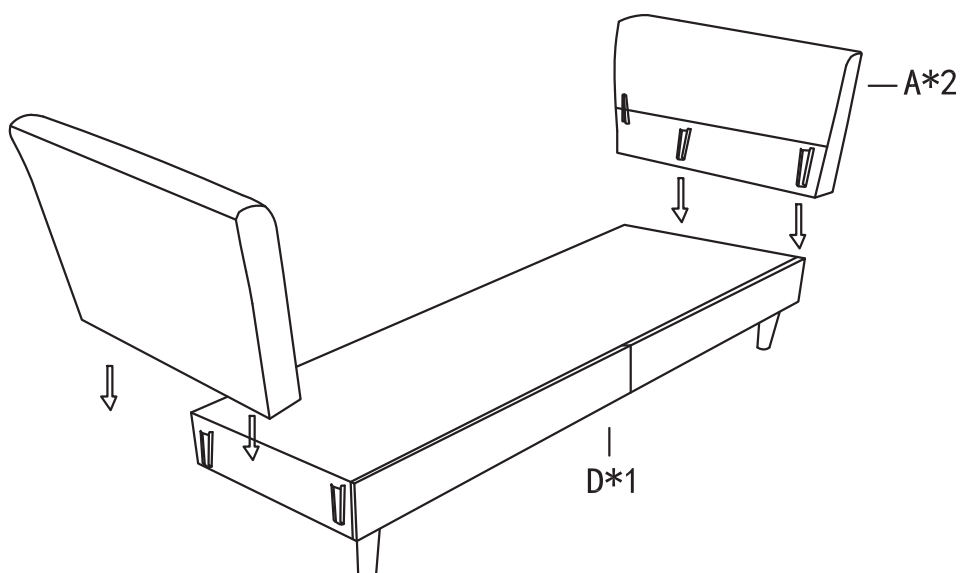

# Step 3

Slide and align the inserts on both sides of the backrest B with the armrest inserts on both sides and press them to secure.

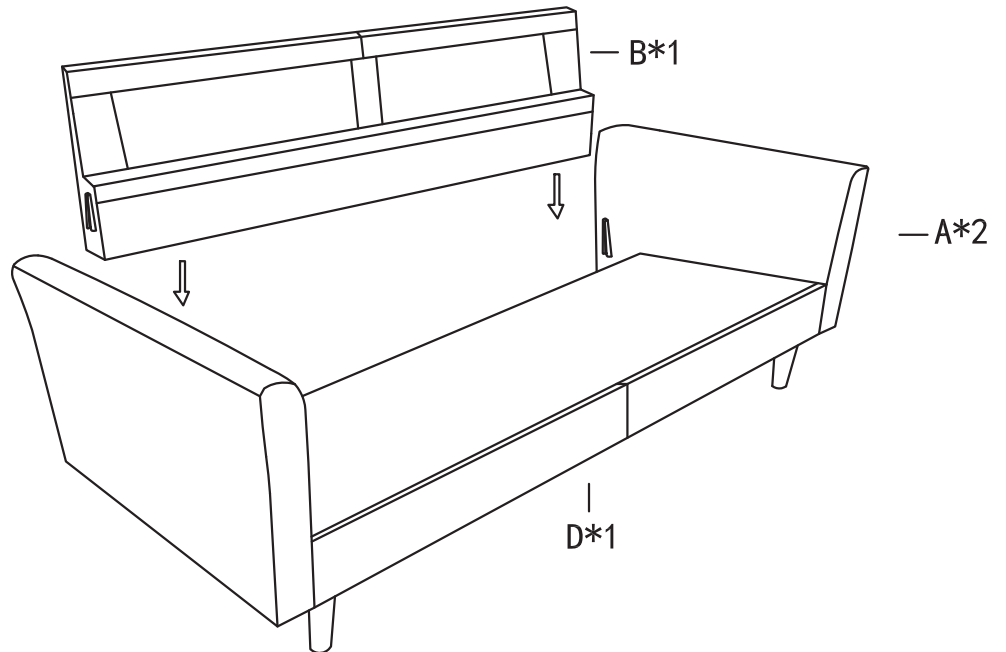

# Step 4

Align seat cushion C and place it on the base plate, while placing headrest E in a suitable position.

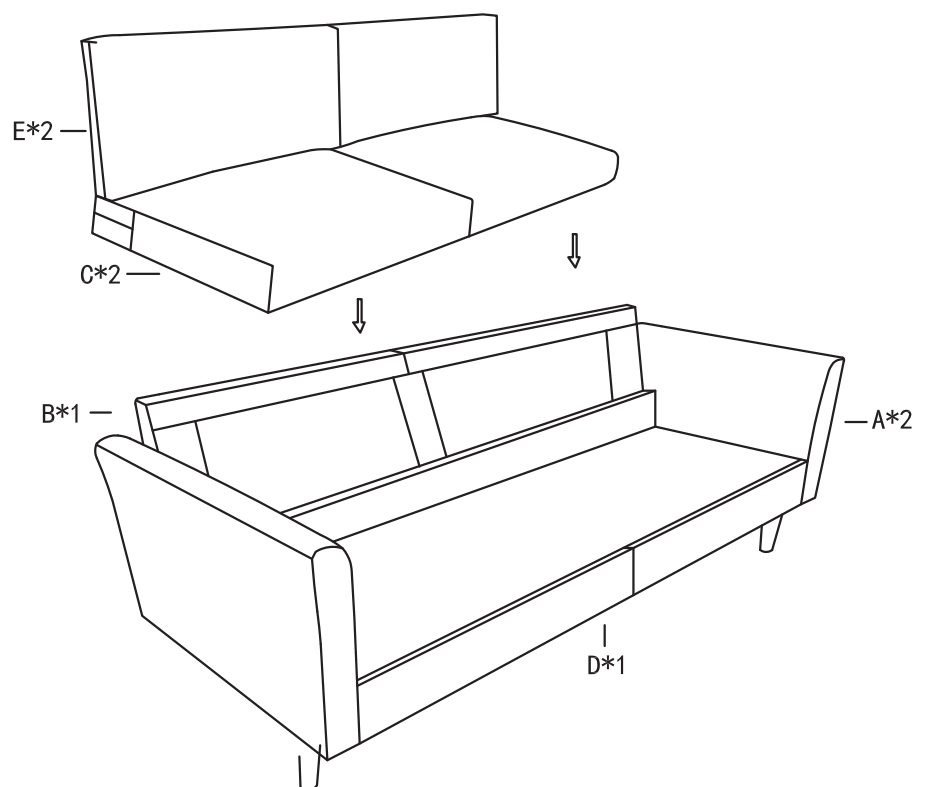

# Finished!

---

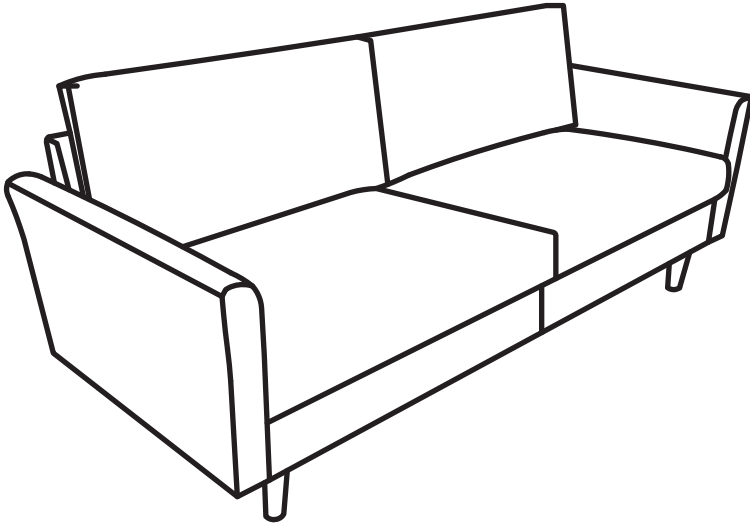

**Congratulations! We're almost there! Please perform following checks to ensure assembly is properly done.**

- Have you tighten all the screws? Sit on the couch to check if the legs are shaky.
- Are the back cushions and armrests fixed properly  
Try pushing them to check if they are tightly in position.
- Adjust and pull the fabric upholstery to remove any wrinkles and ensure correct placement.

Move your product carefully, with 2 people lifting it to the preferred location. Clean the product with a damp cloth. You are all set!

Enjoy your fresh and updated living space thanks to the addition of your new product!

# Care Instructions

JUST ADD TLC! Your furniture, if treated with respect and love, will last you a long time. Each piece requires light maintenance to maximise daily comfort and improve its longevity. Like anything, if you treat it well, that kindness will be repaid back to you. Your furniture is designed to support you and put a smile on your face. It is there to enhance your home, and your life.

1. Position the sofa away from direct sunlight or use curtains or blinds to limit the exposure.
2. Clean the sofa regularly with a dry, soft cloth or a vacuum cleaner with a soft attachment.
3. To remove stubborn stains on fabric, blot affected area immediately with a soft cloth soaked in warm water and mild soap. Then clean off using a dry cloth.
4. Take care not to clean with excessive rubbing. It may damage the weave and discolor the fabric.
5. We recommend fixing felt pads underneath the sofa to prevent scratches on the floor. Placing a rug underneath can also add the right amount of protection and shine to your living space!
6. For optimal care, you should distribute the weight evenly on the cushion regularly.

Follow the care instructions and look after your furniture, in return, your furniture will look after you.

We hope to see you soon!

# Frequently Asked Questions

## **1.What should I do if my shipment is damaged or products received are defective?**

We're sorry to hear that! Please contact us on the platform and provide a detailed description of the damage, as well as photos (or videos, where appropriate) showing the damage. We will do our best to1. Resolve the issue as soon as possible.

## **2.Can replacement parts be ordered?**

Just write to our customer service team on platform and let us know your order ID, and we will be happy to provide further assistance.

## **3.Who do I contact for repair queries?**

You can write to us to specify your inquiry, and we will be able to assist you further.

## **4.What warranty do you offer for your products?**

You can print a copy of the order from the order details on platform, upload it as proof of your purchase. For more detailed information, please visit Warranty section.

## **5. How do I claim my warranty?**

Easy! Just email us and provide a detailed description of the fault as well as photos.

## **6.What should I do if I want to return the product?**

We offer 30-day return policy upon product received. To initiate a return request, please message us and with your reason of returning so we can facilitate the request and assist you further. For more details on the return policy, please refer to Return section.

# Warranty & Return

## 1 YEAR LIMITED WARRANTY STATEMENT FOR MANUFACTURING DEFECTS

Please read this limited warranty carefully. To maintain your warranty, you will need to comply with the conditions stated here. This warranty is for manufacturing defects only and does not cover damages as a result of misuse.

1. The warranty starts on the date of receipt. No warranty will be honored without a proof of purchase. The warranty and financial responsibility of the manufacturer only applies to the products itself.
2. Manufacturing defects include circumstances where the product has broken under normal use and no longer provides proper support. In the event you encounter a manufacturing defect, please stop using this product immediately and contact customer service.
3. This warranty applies only when the product has been properly used by consumers who purchased the product from authorized channels as a new product. Proper use means using the product on a level surface where all legs touch the floor with an equal distribution of weight. Proper use also means that the product was not abused by the consumer, as defined by the manufacturer. This warranty does not constitute agreement to replace other parts.
4. If the product fails due to manufacturing defects, the manufacturer will repair or replace at its discretion and reserves the right to substitute comparable materials or models and guarantee that the replacement part will match existing pieces.
5. In the event the product needs to be inspected by the manufacturer to determine a warranty claim, the transportation cost or removal cost is borne by the consumer.

## 30-DAY RETURN POLICY

We believe you will be thrilled with your purchase from our store. That's because we go out of our way to ensure that products are designed and built to be just what you need. We understand, however, that sometimes a product may not be what you expected it to be. In that event, we invite you to review the following terms related to returning a product.

## **The Return**

Returns are to be made within 30 days of the date you received the product. To initiate return request, please contact our customer service team with your reason of returning so we can facilitate the request and issue return authorization to you. Please note the policy is subject to the conditions below:

1. Only undamaged items in original packaging will be accepted under the Returns Policy. Any items that are not returned to us in the original packaging and/or in original condition will incur an additional handling fee (deducted from your refund). It is your responsibility to package the item sufficiently to avoid damage in transit back to us. We encourage customers to photograph the items scheduled for return and the condition of the packaging before handing over to the delivery company.
2. We will not refund a product that you have bought and received where, in our reasonable opinion, the product has: become of unacceptable quality due to fair wear and tear; misuse; using it in an abnormal way; or failure to take reasonable care.
3. We will not be able to offer standard return policy after 30-day timeframe has passed. However, our customer service team is always an email away if you require further assistance with your products

## **The Refund**

We will assist you to complete the return process. We will perform standard inspection upon your return is received and will send you a message to acknowledge the return if item is presenting in original condition with original packaging.

You will be refunded the full amount less return shipping cost. Please note that while shipping charges on original deliveries are subsidized, on returns the full shipping amount paid by our store to the delivery partner will be deducted from your refund. All refunds will take 2 business days to process upon return acknowledgement from us, however actual fund reversal date will depend on your card company's own processing schedule.

Kindly note, in the event of returning a defective or damaged item, we will however absorb the shipping charges and ensure your return/exchange experience is hassle free.

## **The Exchange**

We put quality as one of our top priorities – we work with experienced manufacturers and have every piece of our product going through strict quality control process. We want to make sure your product reaches you safe and sound, however we are happy to do an exchange in case you receive a defective or damaged product due to any unforeseen hiccups throughout the journey. Please message us and our customer service will evaluate the exchange request, and assist you throughout the process accordingly.