

One-Year Limited Warranty

KES warrants its products purchased from authorized sellers to be free from defects in material and workmanship for one (1) year from the original date of purchase.

What We Will Do

KES will repair or replace, FREE OF CHARGE, during the one (1) year warranty period, any part that proves defective in material and/or workmanship under normal installation, use and service. If repair or replacement is not practical, KES may elect to refund the purchase price in exchange for the return of the product.

What Is Not Covered

KES shall not be liable for any damage to the product resulting from reasonable wear and tear, installation and maintenance errors, outdoor use, freezing water, abuse, misuse, and use of cleaners containing abrasive cleansers, ammonia, bleach, acids, waxes, alcohol or other organic solvents.

KES is not responsible for removal, installation, labor charges, or other incidental or consequential costs. In no event shall the liability of KES exceed the purchase price of the product.

KES AND/OR SELLER ARE PROVIDING THESE WARRANTIES IN LIEU OF ALL OTHER WARRANTIES, EXPRESSED OR IMPLIED, INCLUDING BUT NOT LIMITED

TO THE IMPLIED WARRANTIES OF MERCHANTABILITY AND FITNESS FOR A PARTICULAR PURPOSE. KES AND/OR SELLER DISCLAIM ALL LIABILITY FOR SPECIAL, INCIDENTAL OR CONSEQUENTIAL DAMAGES.

Some jurisdictions do not allow the exclusion or limitation of incidental or consequential damages, so these limitations and exclusions may not apply to you. This warranty gives you specific legal rights and you may also have other rights which vary from jurisdiction to jurisdiction.

This warranty applies only to KES products sold in North America and Europe.

Contact KES

Email: cs@keshome.com
Online Contact:



Please provide:

- dated proof of purchase
- description of the defect/fault
- picture or video showing the issue(s) (optional)

KES

VESSEL SINK INSTALLATION GUIDE

Model

BVS110	BVSS125	BWS100
BVS121	BVSO126	BWSC101
BVS122	BVSO127	
BVS123	BVSR128	
BVS124	BVSC129	
	BVSC138	

CUSTOMER SERVICES

keshome.com
cs@keshome.com



CHAT NOW

BVS.BWS.V5.0

After-sale Service



24-Hour Customer Support

Visit our customer support center at www.keshome.com/cs, available 24/7. Contact us via Amazon Message, instant chat, and email during business hours.



Free Replacement Parts

Please contact us if any parts are damaged or missing. Parts provided free. (Shipping fees may apply)



1-on-1 Responsive Customer Service

No need to restate your case with each contact. Our dedicated team of professionals will work on resolving your issue until it is resolved.



Parts Customization

No need to worry about unexpected challenges. Share your requirements, and we'll customize parts to meet your specific needs.



Return Policy

Feel free to return within 30 days. Please ensure all items (particularly the hardware pack) are in the box before returning.

Missing Return Window?

No Worry!
We totally understand



Contact us
Replace for FREE



EN WARNING: Handle carefully to avoid breakage and potential injury.

DE WARNUNG: Vorsichtig behandeln, um Bruch und mögliche Verletzungen zu vermeiden.

FR AVERTISSEMENT: Manipulez avec soin pour éviter la casse et les blessures potentielles.

ES ADVERTENCIA: Maneje con cuidado para evitar roturas y posibles lesiones.

IT AVVERTENZA: Maneggiare con cura per evitare rotture e potenziali infortuni.

PL OSTRZEŻENIE: Obsługuj ostrożnie, aby uniknąć złamania i potencjalnych obrażeń.

NL WAARSCHUWING: Voorzichtig hanteren om breuk en mogelijk letsel te voorkomen.

SV VARNING: Hantera försiktigt för att undvika brott och potentiella skador.

TR UYARI: Kırılmayı ve olası yaralanmaları önlemek için dikkatli kullanın.



WARNING

Inspect the sink before installation to ensure no damage during shipping. Additional floor and wall preparations may be required to prevent any damage to the sink.

INSTALLATION TYPE: ABOVE THE COUNTERTOP

Warning: Do not use epoxy resin glue or sealing materials that will increase in volume after hardening. KES will not be responsible for any resulting losses caused by doing so.

Model #: BVS110 / BVS121 / BVS122 / BVS123 / BVS124 / BVSS125 / BVSO126 / BVSO127 / BVS128 / BVSC129 / BVSC138

HELPFUL TOOLS



Safety Goggles

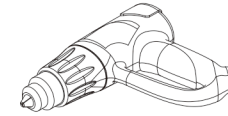

Electric Drill

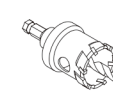

4" Hole Saw



Tape Measure



Pencil



Silicone Sealant

Model #: BVS110 is used as an example for illustration.

- 1 Place the sink in the desired location and mark the centerlines for the drain hole and faucet holes with a pencil.
Please allow a 4" minimum clearance from the wall to the sink for proper installation.

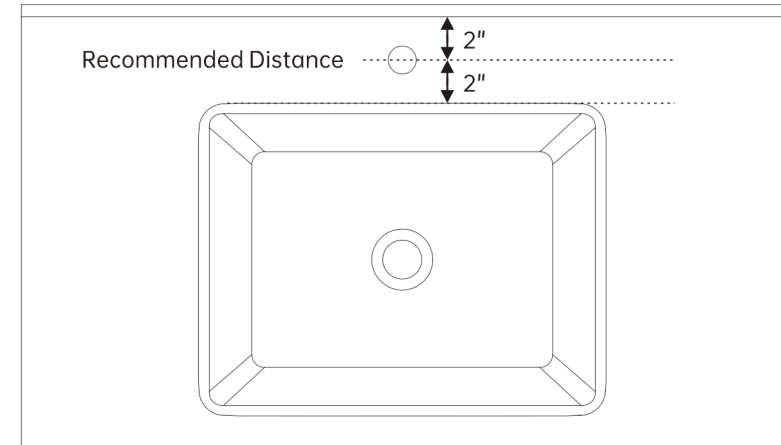

2 Align the mark and carefully cut it with a 4" hole saw.

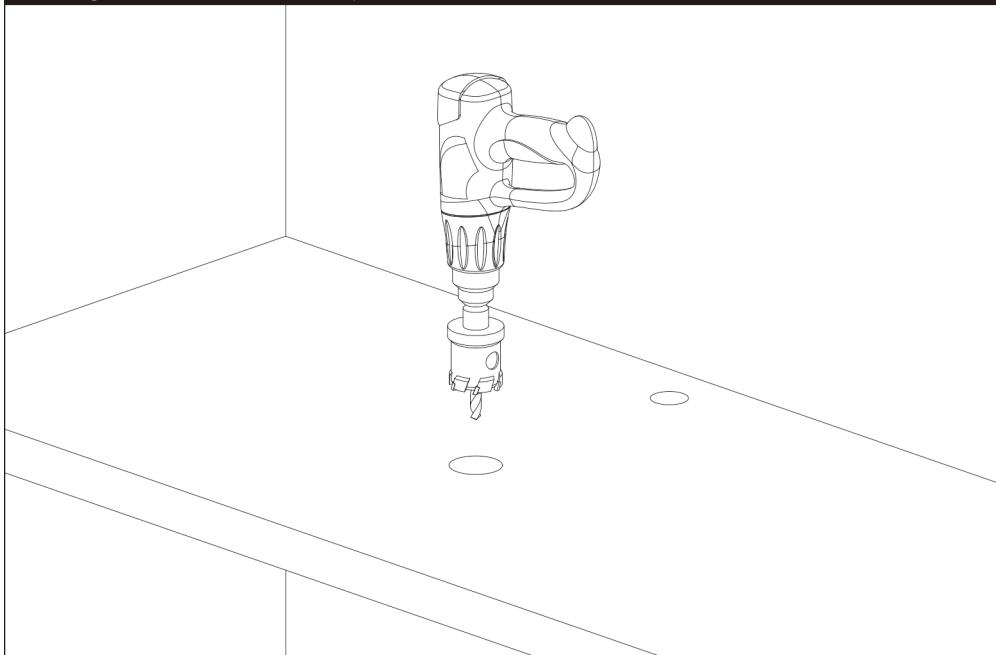

3 Apply silicone sealant around the bottom edge of the sink where it will rest on the countertop.

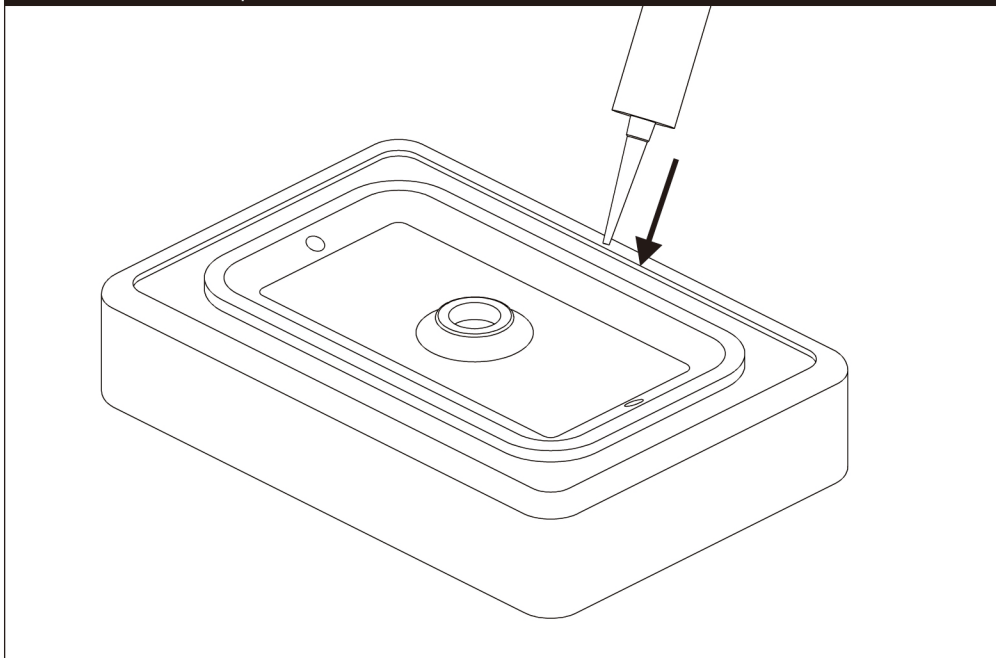

4 Set the sink in place. Note: Do not move the sink until the silicone sealant has fully dried.

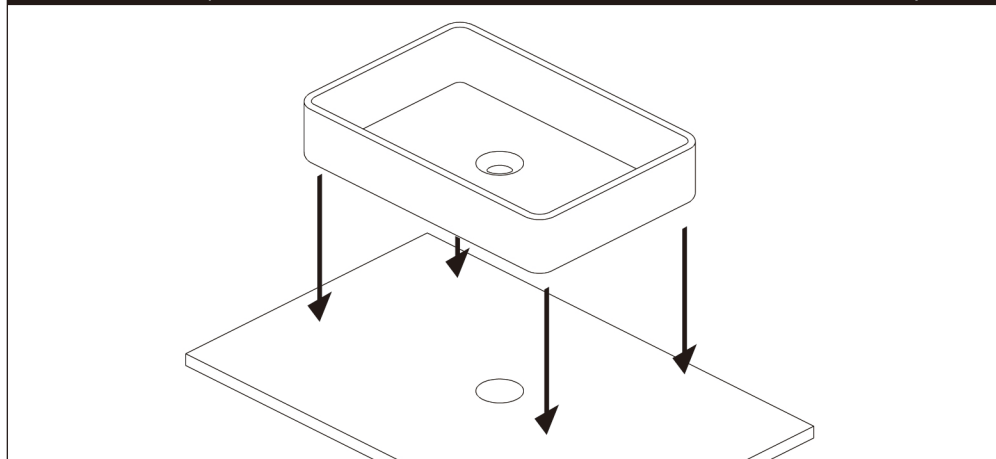

5 After the sink is secured, apply silicone sealant around the entire perimeter where the sink and countertop meet.

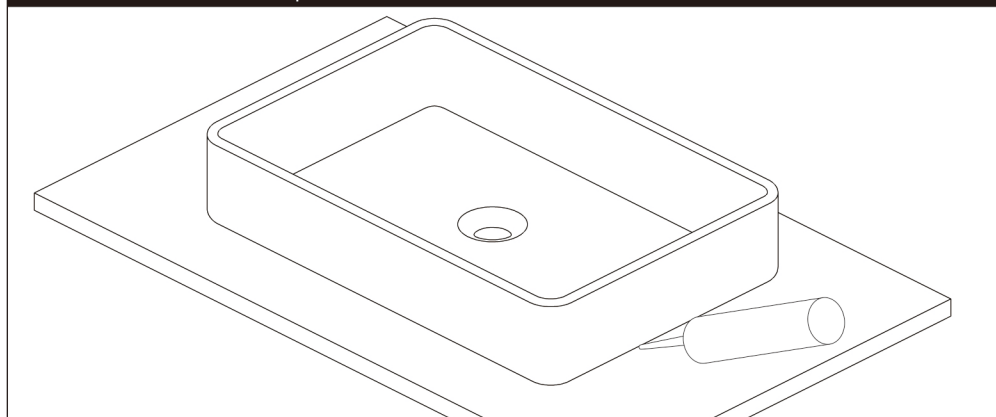

6

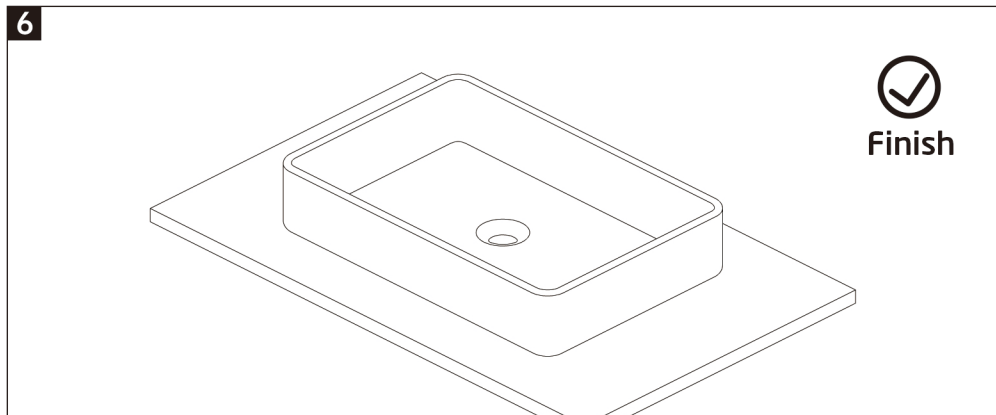

INSTALLATION TYPE:WALL-MOUNT

Model #: BWS100L / BWS100R / BWSC101

HELPFUL TOOLS



Electric Drill



Gradienter



Adjustable Wrench



Pencil

Model #: BWS100L is used as an example for illustration.

PRODUCT COMPONENTS

