

ASSEMBLY INSTRUCTIONS

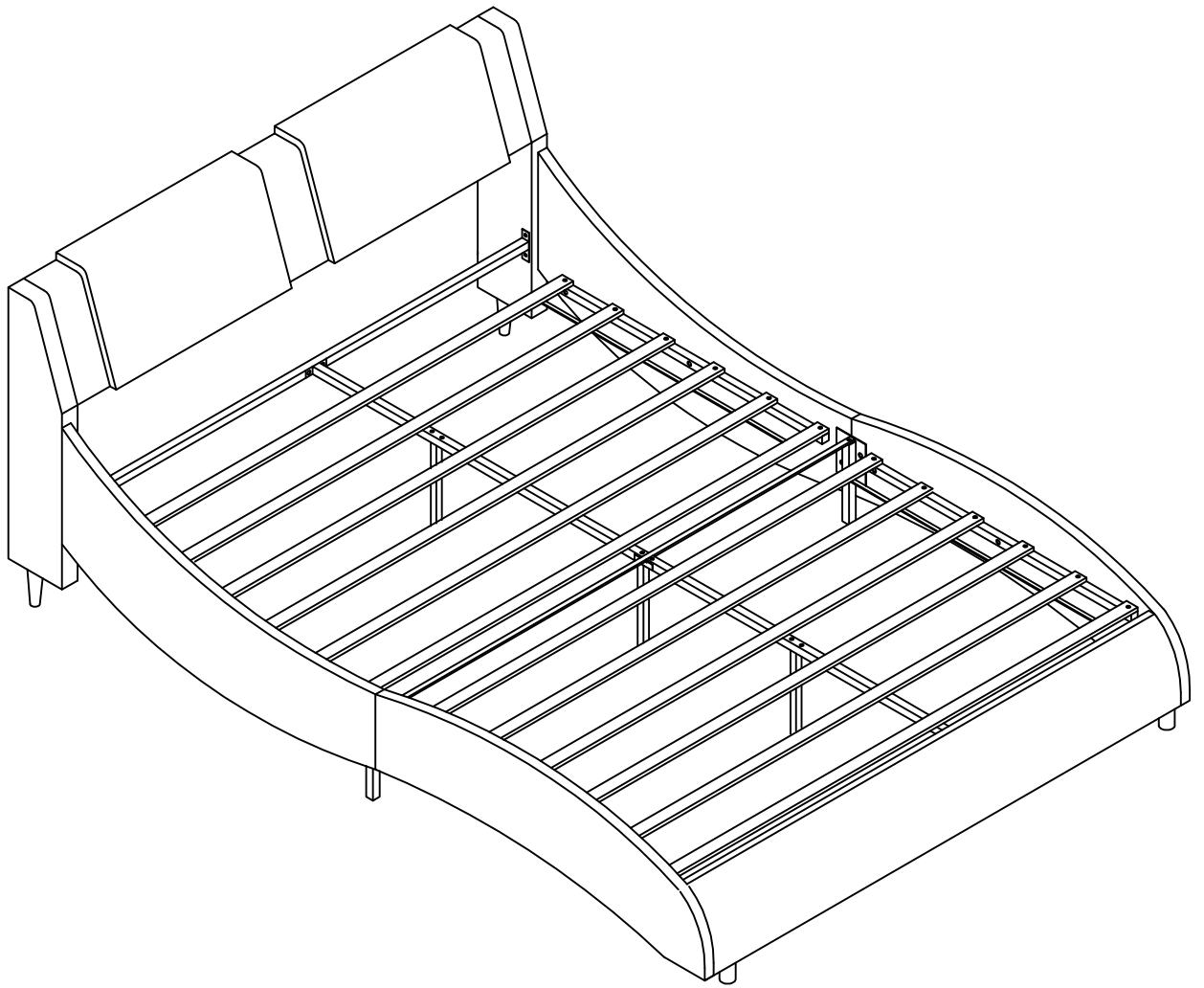

Detail View

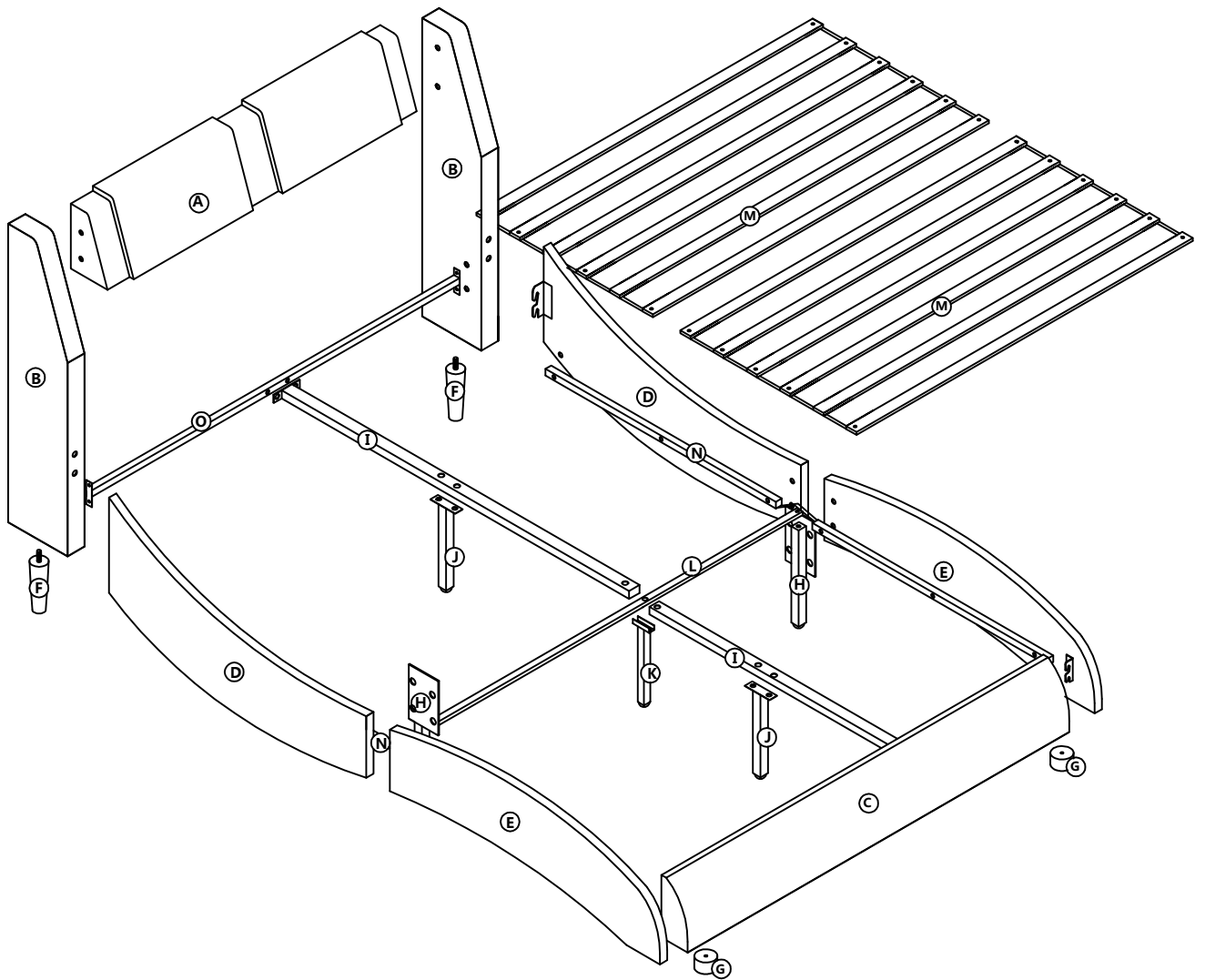

Part List

A

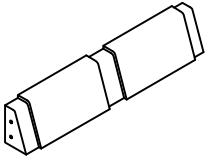

Headboard-1pc

B

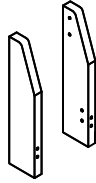

Wing Back-2pcs

C

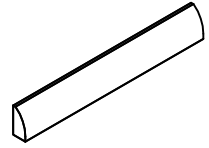

Footboard-1pc

D

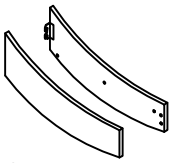

Side Rail-2pcs

E

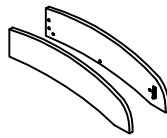

Side Rail-2pcs

F



HB Leg-2pcs

G



FB Feet-2PCS

H

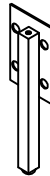

Side Rail Feet-2pcs

I

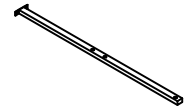

Support Rail-2pcs

J

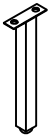

Support Leg-2pcs

K

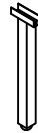

Center Support Leg-1pc

L



Center Crossband-1PC

M

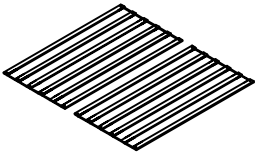

Slats-12pcs

N

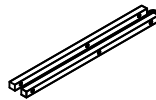







SR Bar-2pcs

O



Crossband-1pc

Hardware List

1  5/16"×25mm Bolt (14pcs)	2  5/16"×50mm Bolt (15pcs)	3  1/4" x 17mm Bolt (8pcs)
4  5/16"*19mm Flat washer (37pcs)	5  5/16" Allen Key (1pc)	6  M8*25mm Screw (24pcs)
7  5/16" Nut (8pcs)	8  5/16" Box Wrench (1pc)	9  1/4"×38mm Bolt (12pcs)
10  1/4"*16mm Flat washer (20pcs)	11  1/4" Allen Key (1pc)	12  M8*50mm Screw (2pcs)

※ Part B in the back storage of part A (Headboard).

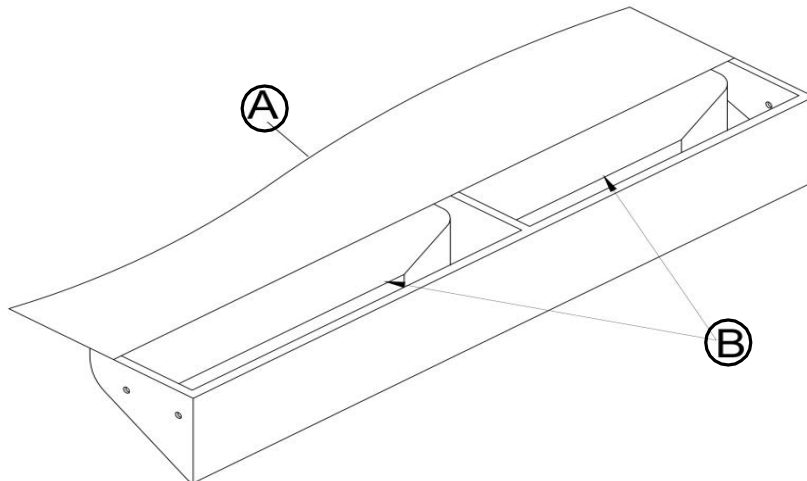

STEP: 1

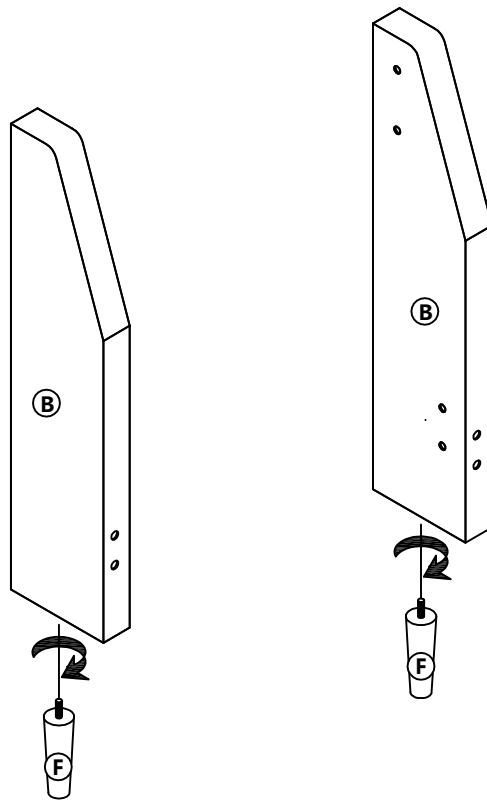

STEP: 2

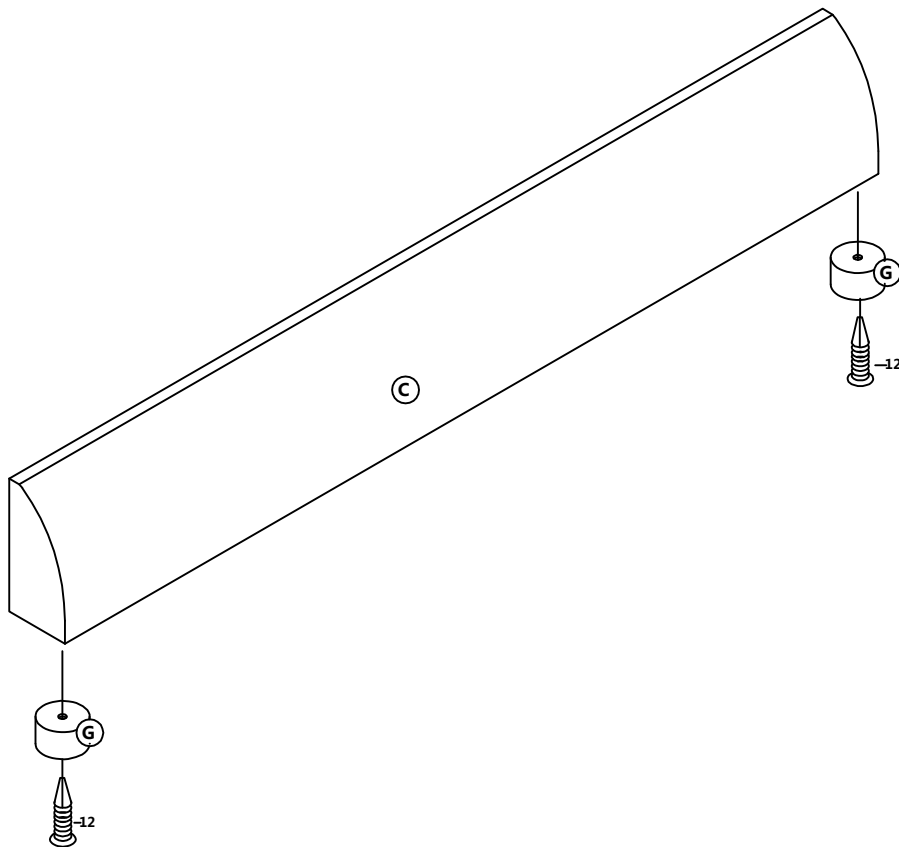



12



2PCS

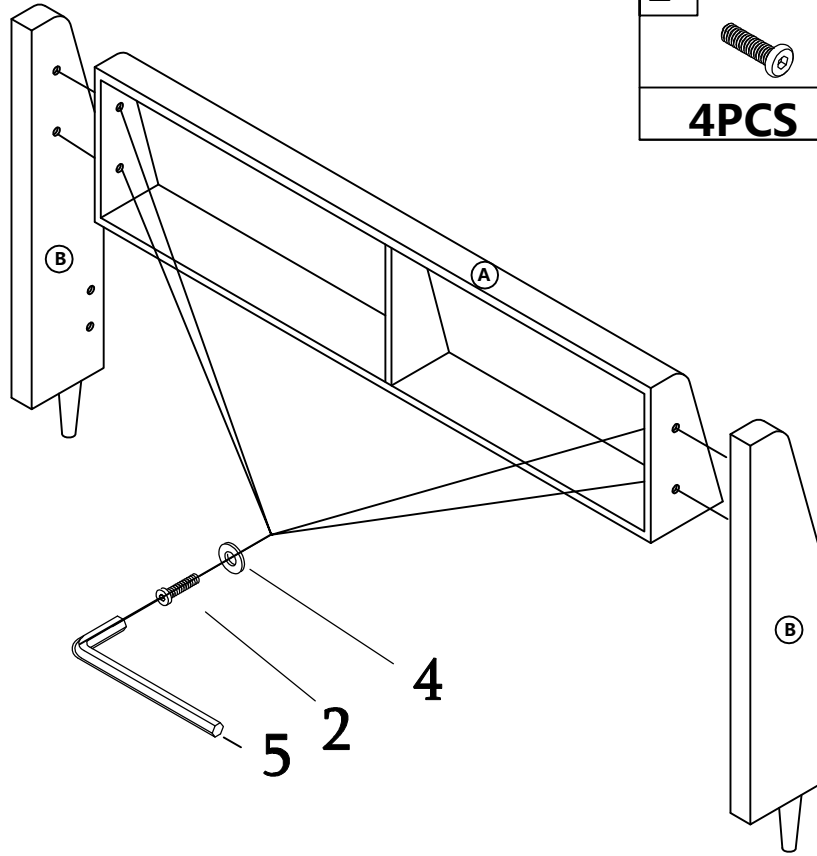

STEP: 3



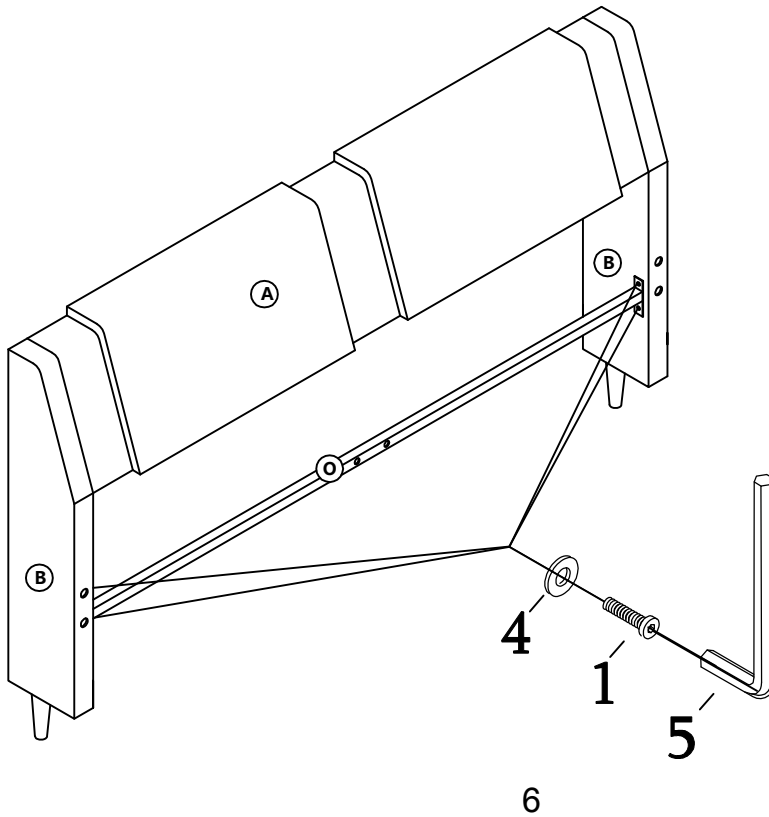

2		4	
4PCS		4PCS	

STEP: 4





1		4	
4PCS		4PCS	

STEP: 5

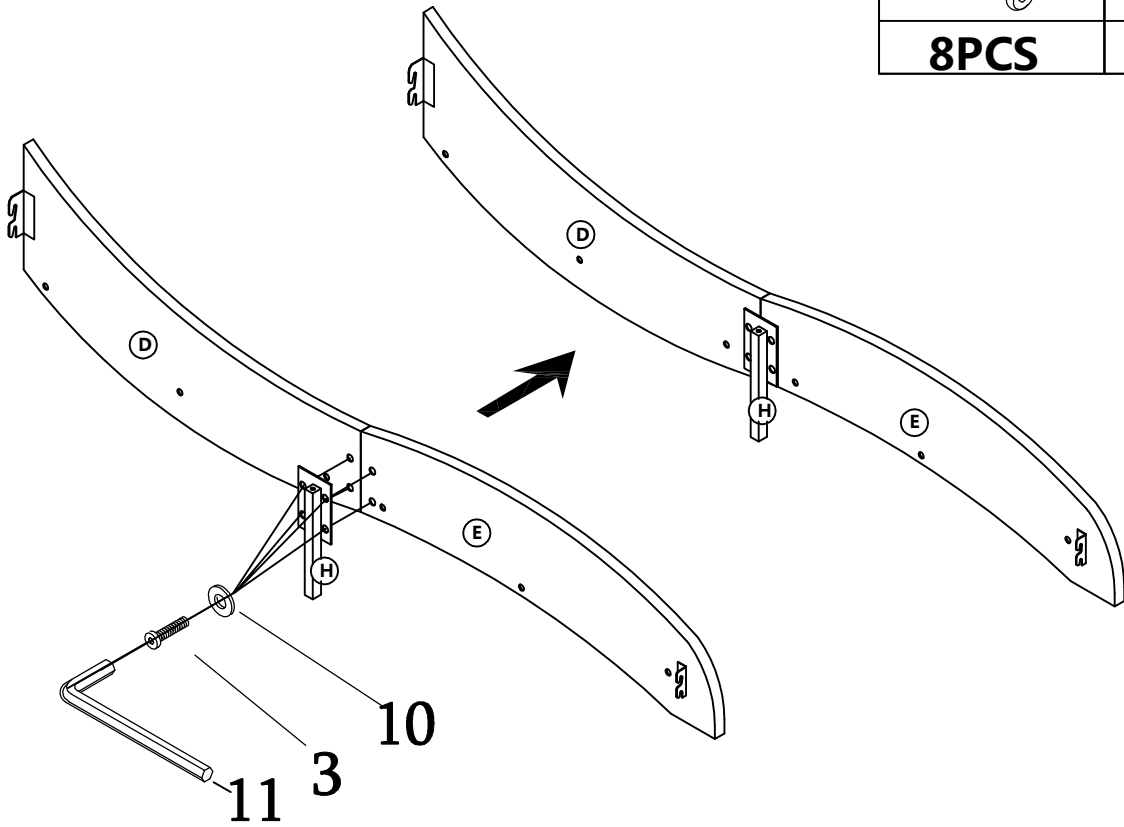
3	10
	
8PCS	8PCS



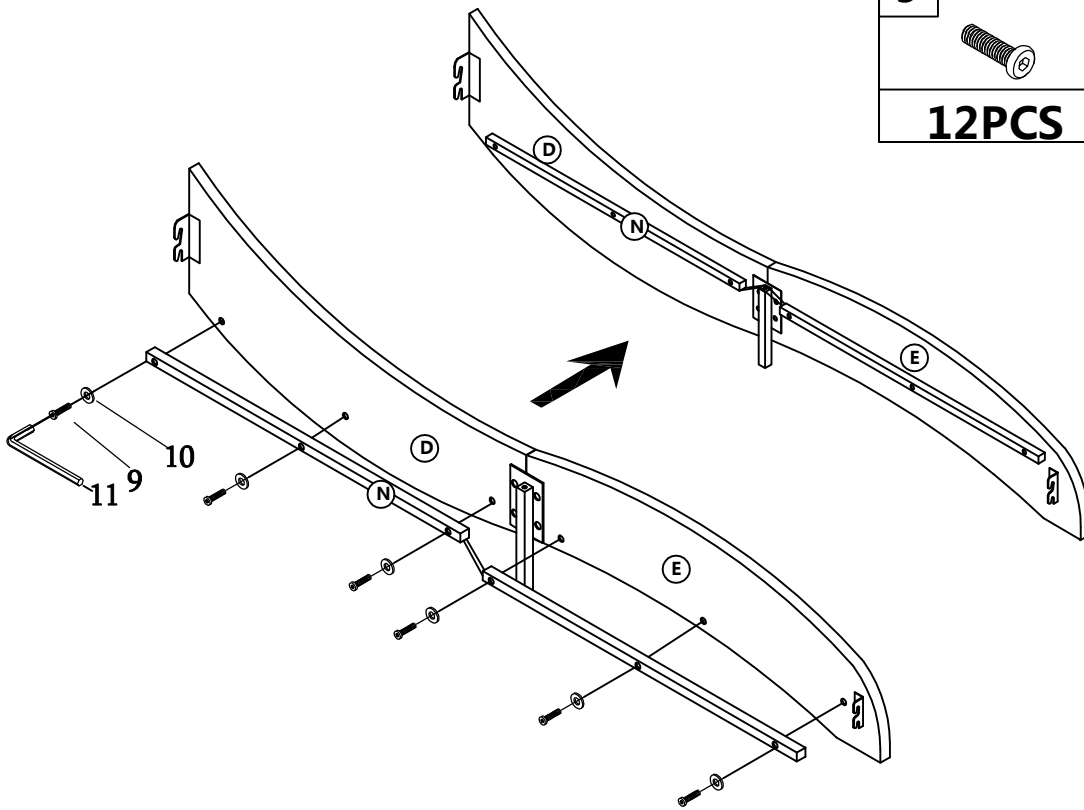

STEP: 6

9	10
	
12PCS	12PCS



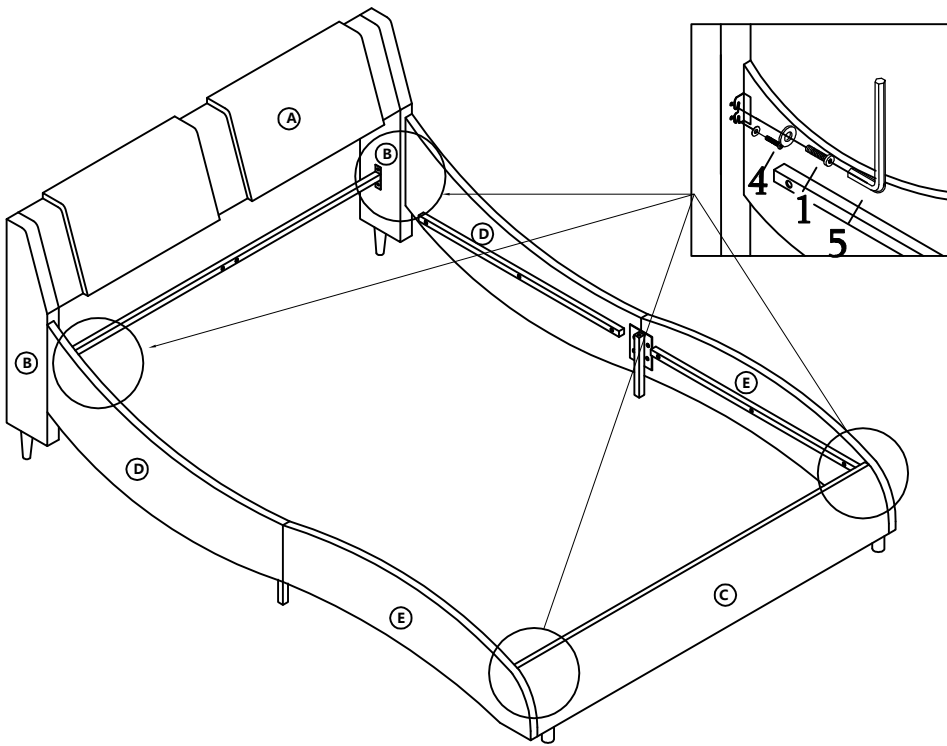



STEP: 7



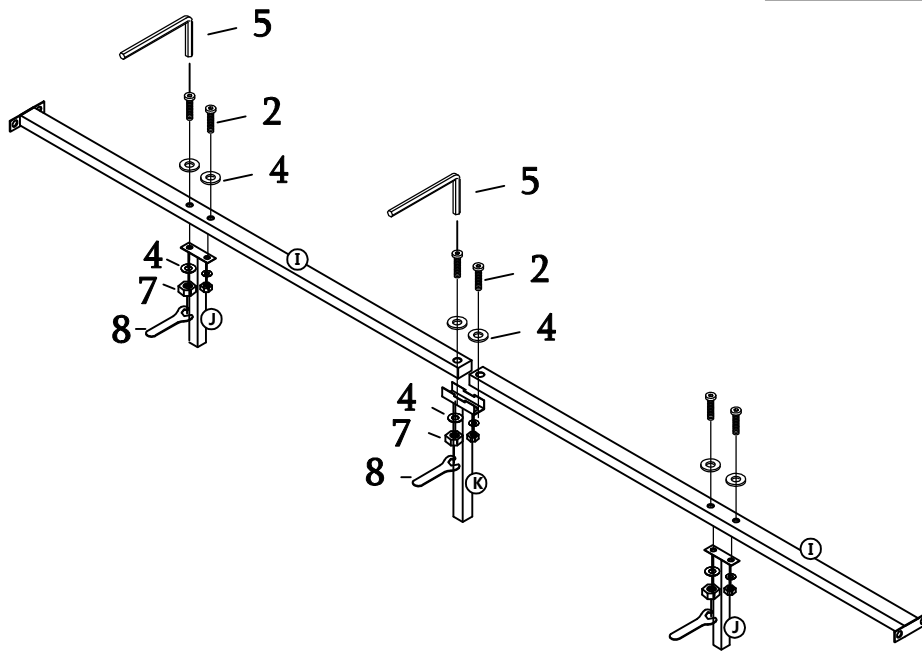



1		4	
8PCS		8PCS	

STEP: 8





2		4		7	
6PCS		12PCS		6PCS	

STEP: 9

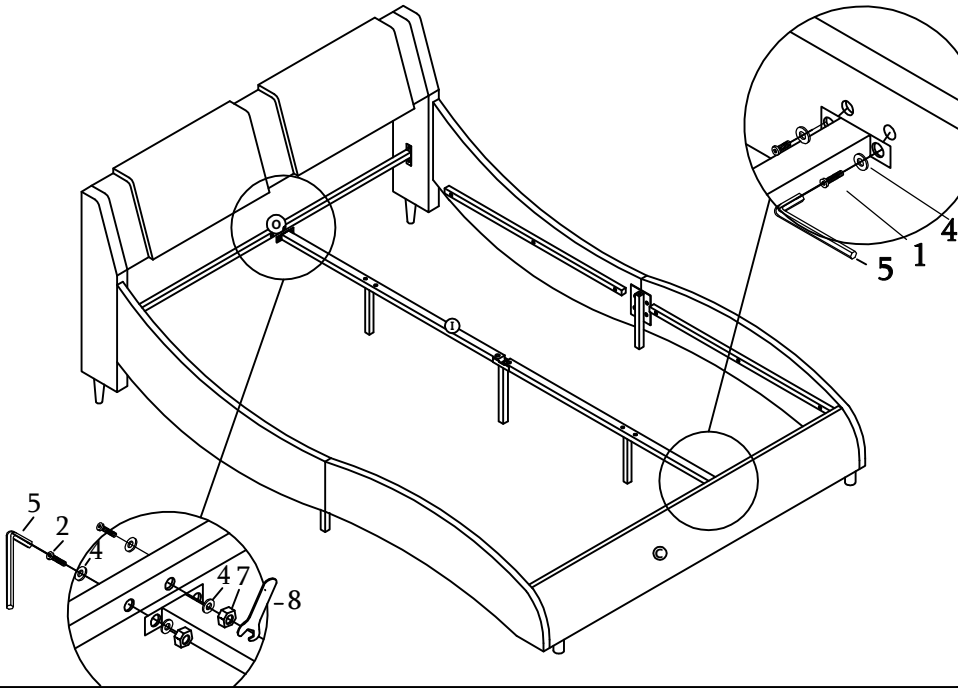
1		2		4		7	
2PCS		2PCS		6PCS		2PCS	



STEP: 10

2		4	
3PCS		3PCS	

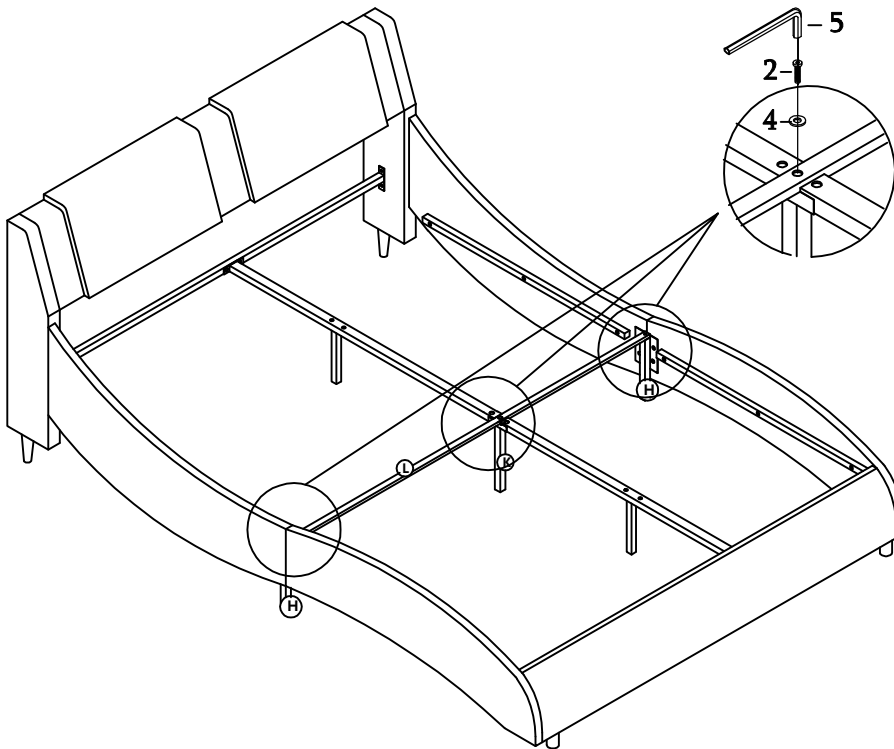

STEP: 11

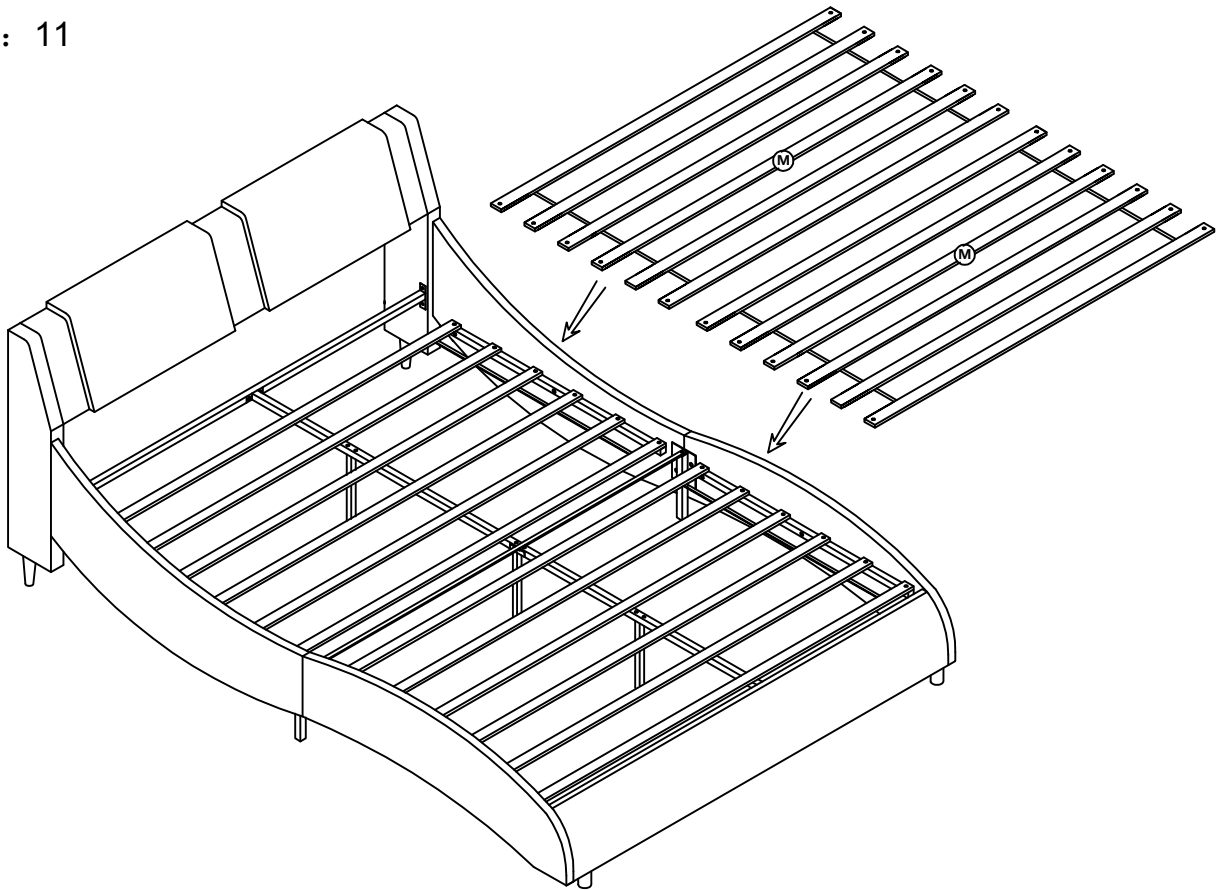

STEP: 12

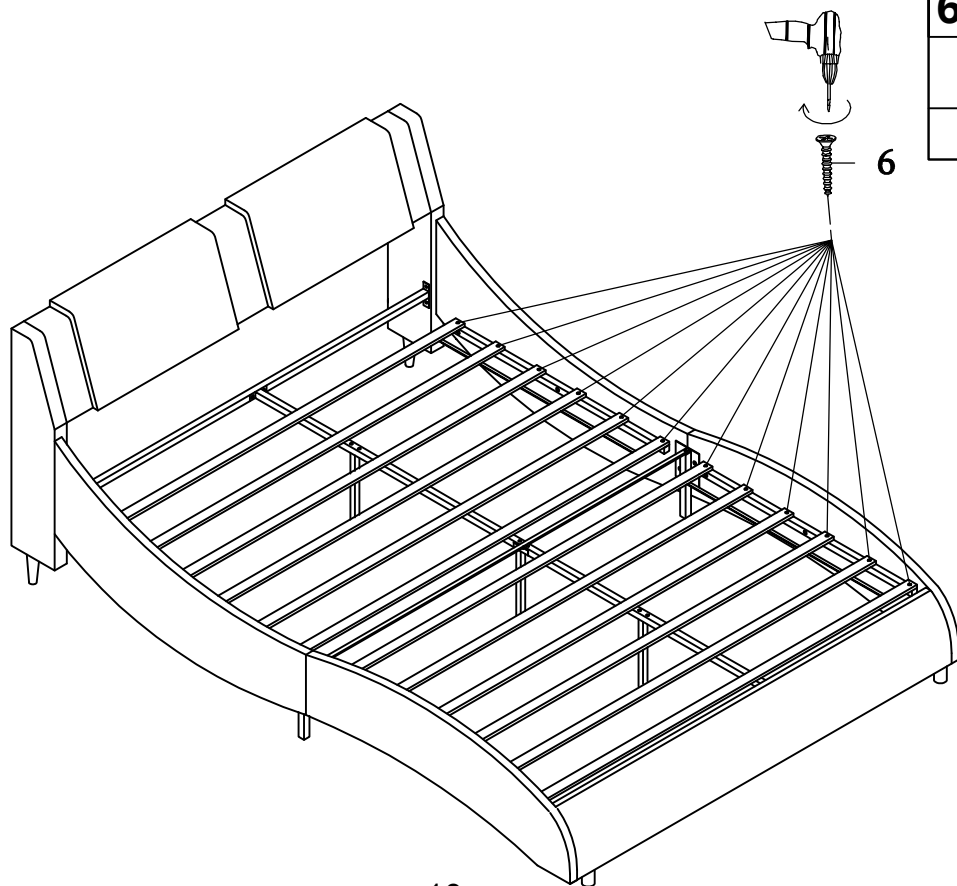

6



24PCS

6

10

STEP: 13

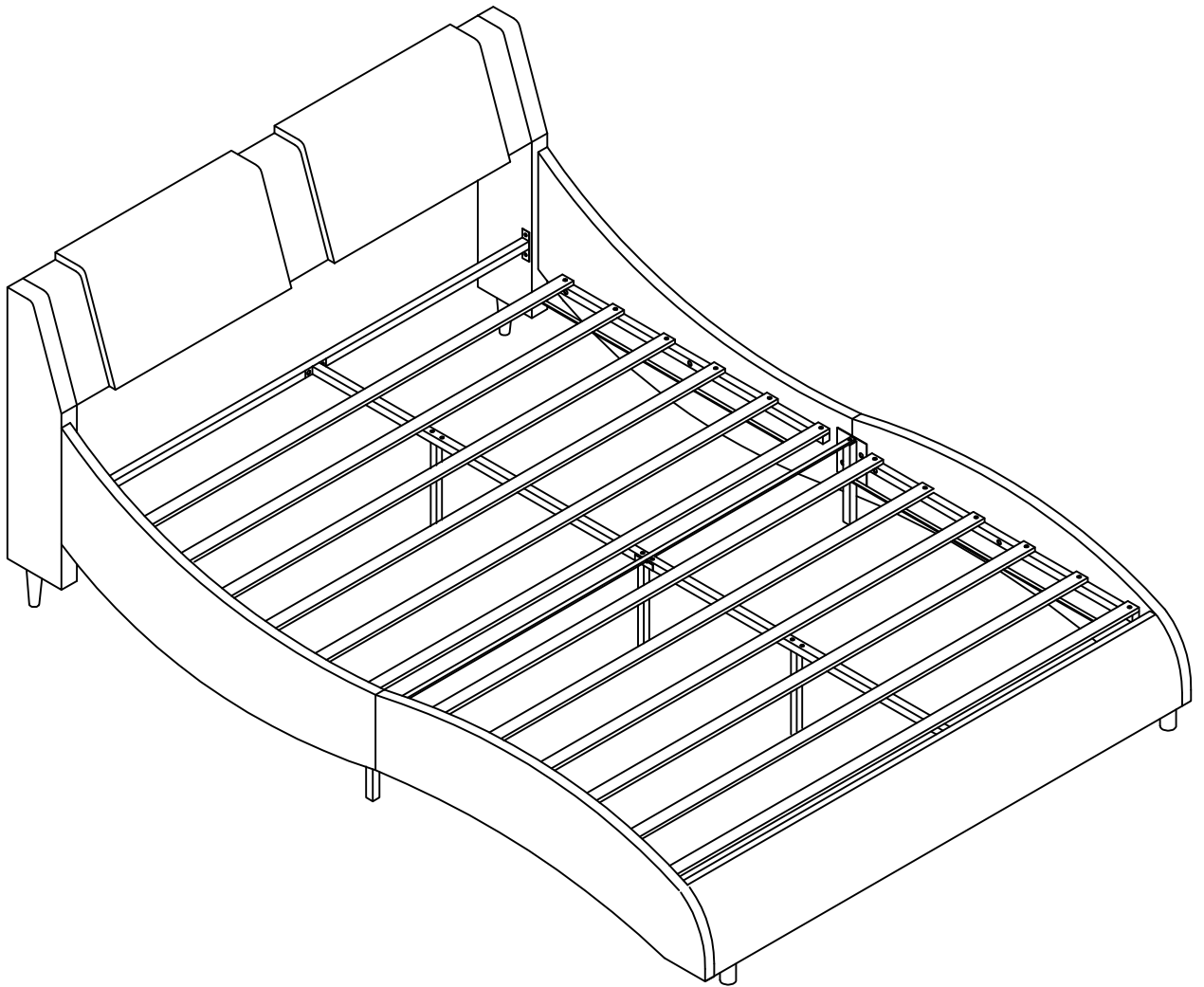

STEP : 14

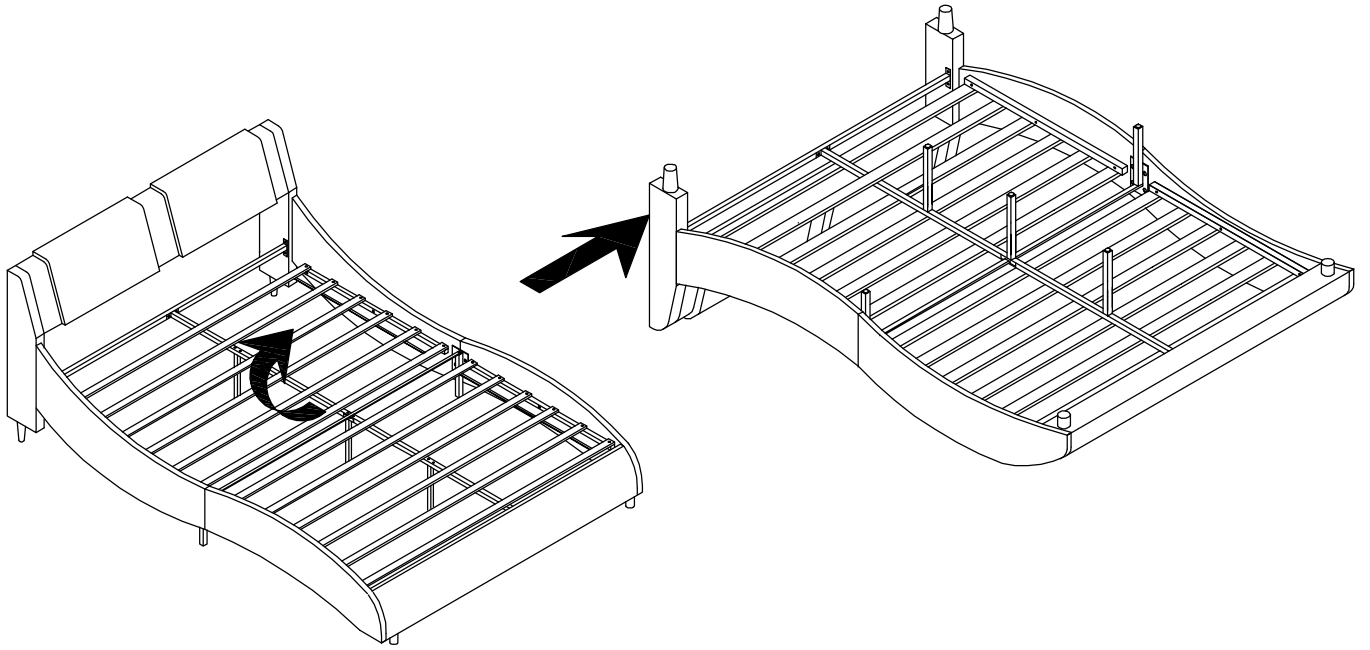

STEP : 15

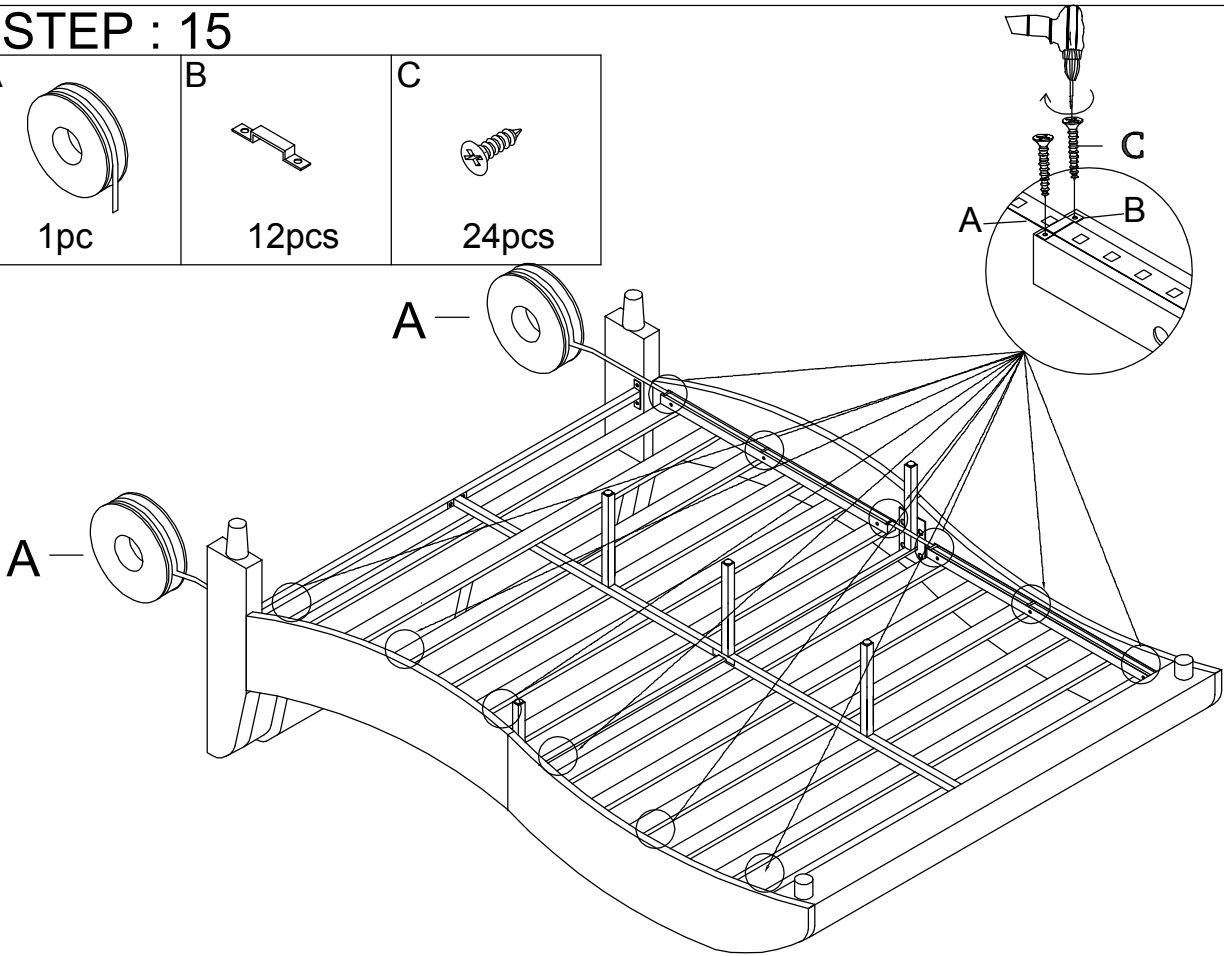
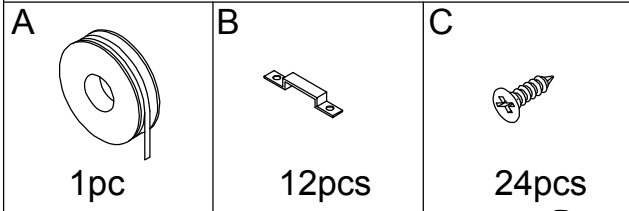

STEP : 16

