

# WARRANTY

We strive to offer high-quality products, and we also try our best to satisfy each and every customer that orders from us with product or service as needed. We provide 30 days warranty starting from the time you receive the item. Each customer must provide a record of their order such as the order number, or item receipt for any items that are out of the warranty period you may also still receive replacement parts by purchasing them with our company if they are available.

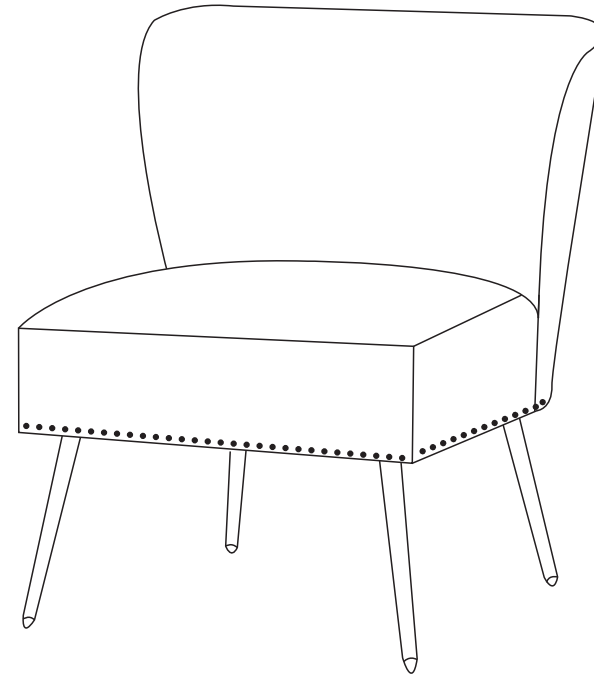

---

## NOTE:

---

This brochure contains IMPORTANT safety info. Please read and keep for future reference.

---

## MAINTAINANCE AND WARNING

- Keep furniture away from heat.
- Do not clean furniture with harsh cleansers or polish. Do not use detergents, Solvents, abrasives, spray packs or leather cleaner. Use non-color mild soap with warm water clean spills(Mix 1:10 soap to water)
- Do not place furniture under direct sunlight, material will possibly fade over time.
- Do not use on site dry Cleaning machine.
- Children should not climb or jump on the furniture.
- Do not write on furniture without a padded barrier to protect the surface.
- Not for commercial use, For residential use only.



Weight Limitation

**250LBS**

## PARTS LIST

Ax1

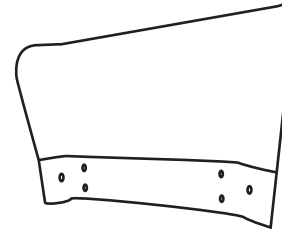

Bx1



Cx4



Estimated Duration Of Assembly

**5-10 MINUTES**

## HARDWARE LIST

Dx6  
M8x55mm



Ex12  
M6x20mm



Fx6



Gx6



Hx1 M8

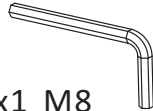

Ix1 M6



## SPARE

Dx1  
M8x55mm



Ex1  
M6x20mm



Fx1



Gx1



Jx1



Be sure to check all packing material carefully for small parts, which may have come loose inside the carton during shipment.

## ASSEMBLY INSTRUCTIONS

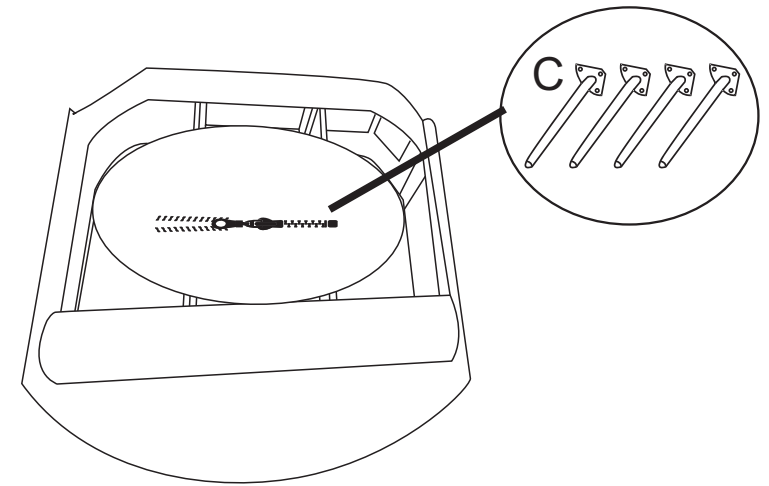

**STEP 1:** Place seat B on clean padded surface. Open the zipper pocket under seat and take legs C and hardware pack out.

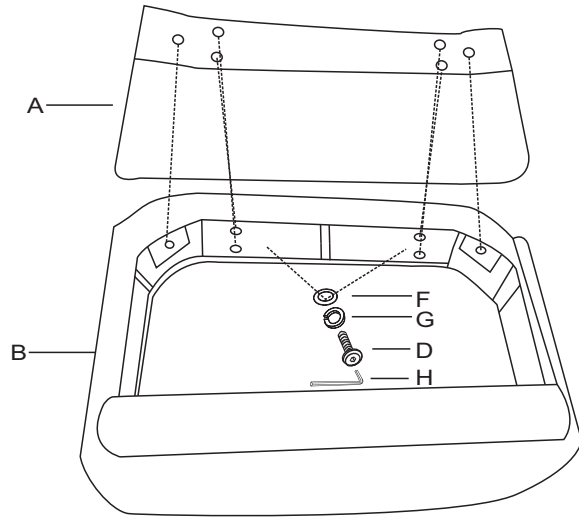

**STEP 2:** Align hole position on seat cushion B and back A, use bolt D, flat washer F, spring washer G, allen wrench H to connect seat and back, make sure bottom edge of back align with rear bottom edge of seat then fasten all bolts to secure.

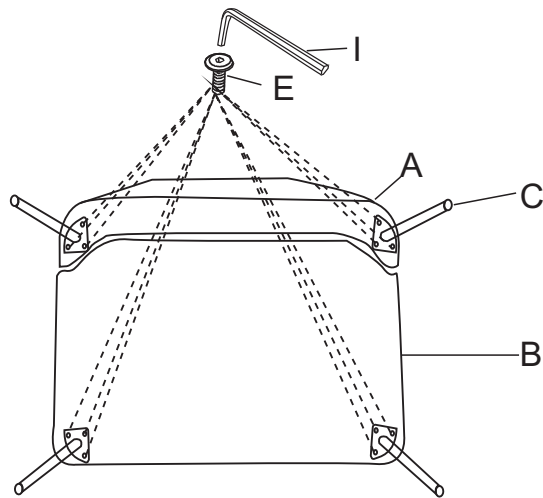

**STEP 3 :** Use bolt E , allen key I to attach legs C to bottom of the seat, fasten all bolts to secure.

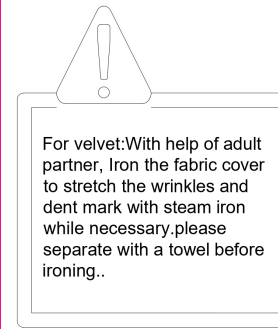

For velvet: With help of adult partner, iron the fabric cover to stretch the wrinkles and dent mark with steam iron while necessary, please separate with a towel before ironing..

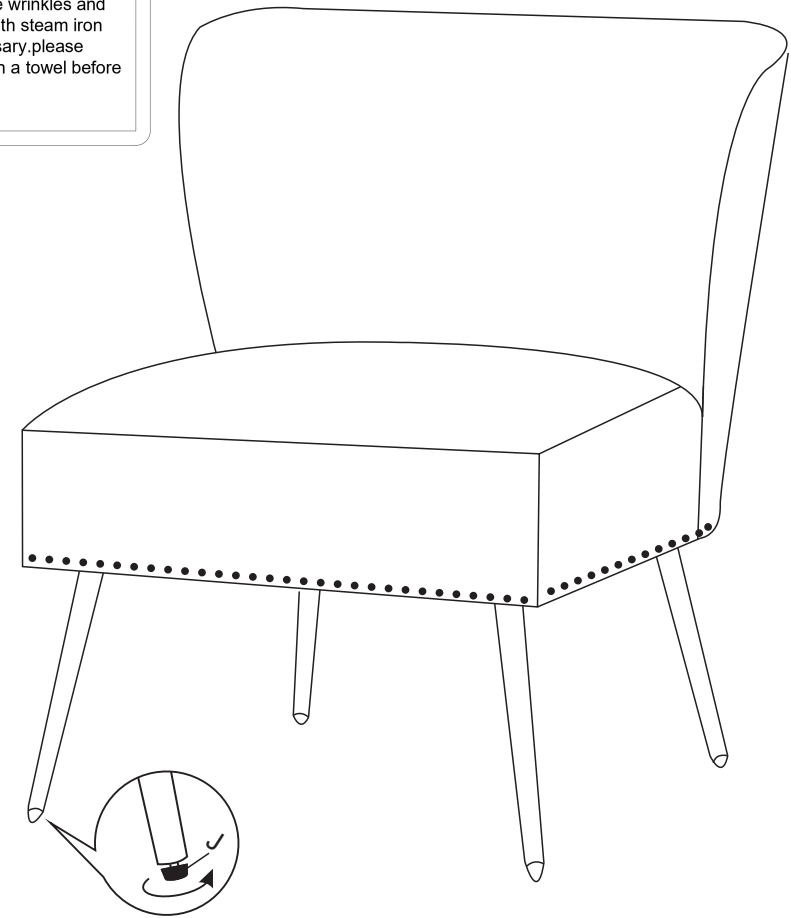

Adjust levelers under legs to set the seat level.

**STEP 4 :** Assembly completed.